

**Have product questions or need technical support?
Contact Us:**



Website: www.poulanpro.com



Toll free: 1-888-676-7909 Mon-Fri 8-4 CST



Email: support@poulanpro-power.us

CONTENTS

Specifications	3
Introduction / Safety Definitions	4
Important Safety instructions	5
Know your product	8
Assembly	9
Operation	11
Maintenance	16
Storage	19
Troubleshooting	20
Basic Service Parts List	21
Warranty Statement	22

SPECIFICATIONS

Snow Thrower Specifications

Model	PR180
Stage	Single
Clearing Width (in.)	18
Clearing Height (in.)	10.5
Wheel Diameter (in.)	7
Starter	Electric and Recoil
Chute Control	Remote, 190 Degrees
Length (in.)	43
Width (in.)	21
Height (in.)	40
Weight (lbs.)	58

Engine Specifications

Engine Model	WM156FSE/P
Displacement	99cc
Type	4-Stroke, Air Cooled, Overhead Valve (OHV)
Fuel Capacity	0.37 Gallon
Fuel Type	Fresh, clean regular unleaded gasoline with a minimum octane rating of 87 and an ethanol content of no more than 10% by volume.
Oil Capacity	12 fl.oz (350 ml)
Oil Type	SAE 5W-30

INTRODUCTION

Congratulations on your purchase of a PoulanPro® product. This model is the result of PoulanPro's vast experiences in the production of high-quality, cost-effective equipment.

It represents the high degree of reliability and innovation that PoulanPro® has dedicated itself to.

This manual will give you an understanding of the assembly, operation and basic maintenance of this unit. If you have any questions concerning the operation or maintenance, please contact us at support@poulanpro-power.us or 1-888-676-7909.

We want you to continue to use and be satisfied with your product for years to come, therefore please fully familiarize yourself, and others who plan on operating the product, with the proper safety and operation procedures before each use.

We continually seek advancements in product design and quality. Therefore, while this manual contains the most current product information available at the time of printing, there may be minor discrepancies between your product and this manual.

When contacting us about parts and/or service, you will need to supply the complete Product and Serial numbers from your unit.

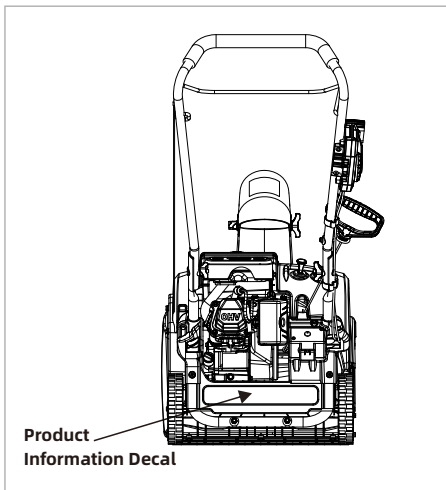

PRODUCT NUMBER

SERIAL NUMBER

DATE OF PURCHASE

SAFETY DEFINITIONS

The purpose of safety symbols is to attract your attention to possible dangers. The safety symbols, and their explanations, deserve your careful attention and understanding. The safety warnings do not by themselves eliminate any danger. The instructions or warnings they give are not substitutes for proper accident prevention measures.

⚠ DANGER

DANGER indicates a hazardous situation which, if not avoided, will result in death or serious injury.

⚠ WARNING

WARNING indicates a hazardous situation which, if not avoided, could result in death or serious injury.

⚠ CAUTION

CAUTION indicates a hazardous situation which, if not avoided, could result in minor or moderate injury.

IMPORTANT SAFETY INSTRUCTIONS

IMPORTANT: This snow thrower is capable of amputating hands and feet and throwing objects. Failure to observe the following safety instructions could result in serious injury.

WARNING

Always disconnect spark plug wire and place it where it cannot contact plug in order to prevent accidental starting when setting up, transporting, adjusting or making repairs.

This snow thrower is for use on sidewalks, driveways and other ground level surfaces. Caution should be exercised while using sloping surfaces. Do not use snow thrower on surfaces above ground level such as roofs of residences, garages, porches or other such structures or buildings.

Snow throwers have exposed rotating parts, which can cause severe Injury from contact, or from material thrown from the discharge chute. Keep the area of operation clear of all persons, small children and pets at all times including startup.

Muffler and other engine parts become extremely hot during operation and remain hot after engine has stopped. To avoid severe burns on contact, stay away from these areas.

Training

1. Read, understand and follow all instructions on the machine and in the manual(s) before operating this unit. Be thoroughly familiar with the controls and the proper use of the equipment. Know how to stop the unit and disengage the controls quickly.
2. Never allow children to operate the equipment. Never allow adults to operate the equipment without proper instruction.
3. Keep the area of operation clear of all persons, particularly small children.
4. Exercise caution to avoid slipping or falling, especially when operating the snow thrower in reverse.

Preparation

1. Thoroughly inspect the area where the equipment is to be used and remove all doormats, sleds, boards, wires, and other foreign objects.
2. Ensure the auger lever is released before starting the engine.
3. Do not operate the equipment without wearing adequate winter garments. Avoid loose fitting clothing that can get caught in moving parts. Wear footwear that will improve footing on slippery surfaces.
4. Handle fuel with care; it is highly flammable.

Use an approved fuel container.

Never add fuel to a running engine or hot engine.

Fill the fuel tank outdoors with extreme care. Never fill fuel tank indoors.

Never fill containers inside a vehicle or on a truck or trailer bed with a plastic liner. Always place containers on the ground, away from your vehicle, before filling.

When practical, remove gas-powered equipment from the truck or trailer and refuel it on the ground. If this is not possible, then refuel such equipment on a trailer with a portable container, rather than from a gasoline dispenser nozzle.

Keep the nozzle in contact with the rim of the fuel tank or container opening at all times, until refueling is complete.

Replace gasoline cap securely and wipe up any spilled fuel.

If fuel is spilled on clothing, change clothing immediately.

5. Use extension cords and receptacles as specified by the manufacturer for all units with electric drive motors or electric starting motors.
6. Never attempt to make any adjustments while the engine (motor) is running (except when specifically recommended by manufacturer).
7. Always wear safety glasses or eye shields during operation or while performing an adjustment or repair to protect eyes from foreign objects that may be thrown from the machine.
8. Use ear protectors to avoid damage to hearing.
9. Never direct the discharge toward people or areas where property damage can occur. Keep children and others away.
10. Do not overload the machine capacity by attempting to clear snow at too fast a rate.
11. Never operate the machine at high transport speeds on slippery surfaces. Look behind and use care when operating in reverse.
12. Disengage power to the auger blades when the snow thrower is transported or not in use.
13. Use only attachments and accessories approved by the manufacturer of the snow thrower.

Operation

1. Do not put hands or feet near or under rotating parts. Keep clear of the discharge opening at all times.
2. After striking a foreign object, immediately stop the engine (motor) by removing the key. Thoroughly inspect the snow thrower for any damage. Repair any damage before resuming operation.
3. If the unit should start to vibrate abnormally, stop the engine (motor) and check immediately for the cause. Vibration is generally a warning of trouble.
4. Stop the engine (motor) whenever you leave the operating position, before unclogging the auger housing or discharge chute, and when making any repairs, adjustments or inspections.
5. When cleaning, repairing or inspecting the snow thrower, stop the engine and make certain the auger blades and all moving parts have stopped. Remove key.
6. Do not run the engine indoors, exhaust fumes are dangerous.
7. Exercise extreme caution when operating on slopes.
8. Never operate the snow thrower without proper guards, and other safety protective devices in place and working.
9. Never operate the snow thrower without good visibility or light. Always be sure of your footing, and keep a firm hold on the handles. Walk; never run.
15. Never touch a hot engine or muffler.

Clearing a Clogged Discharge Chute

WARNING

Hand contact with the rotating auger blades inside the discharge chute is the most common cause of injury associated with snow thrower. Never use your hand to clean out the discharge chute.

To clear the chute:

1. **SHUT THE ENGINE OFF!** Remove the ON/OFF key!
2. Wait 10 seconds to be sure the auger blades have stopped rotating.
3. Always use a clearing tool at least 15 inches long.

Maintenance and Storage

1. Never store the machine with fuel in the fuel tank inside a building where ignition sources are present such as hot water heaters, space heaters, or clothes dryers. Allow the engine to cool before storing in any enclosure.
2. Always refer to operator's manual for important details if the snow thrower is to be stored for an extended period.
3. Maintain or replace safety and instruction labels, as necessary.
4. Run the machine a few minutes after throwing snow to prevent freeze-up of the collector/impeller.

Customer Responsibilities

Read and observe the safety rules.

Follow a regular schedule in maintaining, caring for and using your snow thrower.

Follow the instructions under "Maintenance" and "Storage" sections of this manual.

KNOW YOUR PRODUCT

Read this operator's manual before operating your snow thrower. Familiarize yourself with the location and function of the controls and features.

Save this manual for future reference.

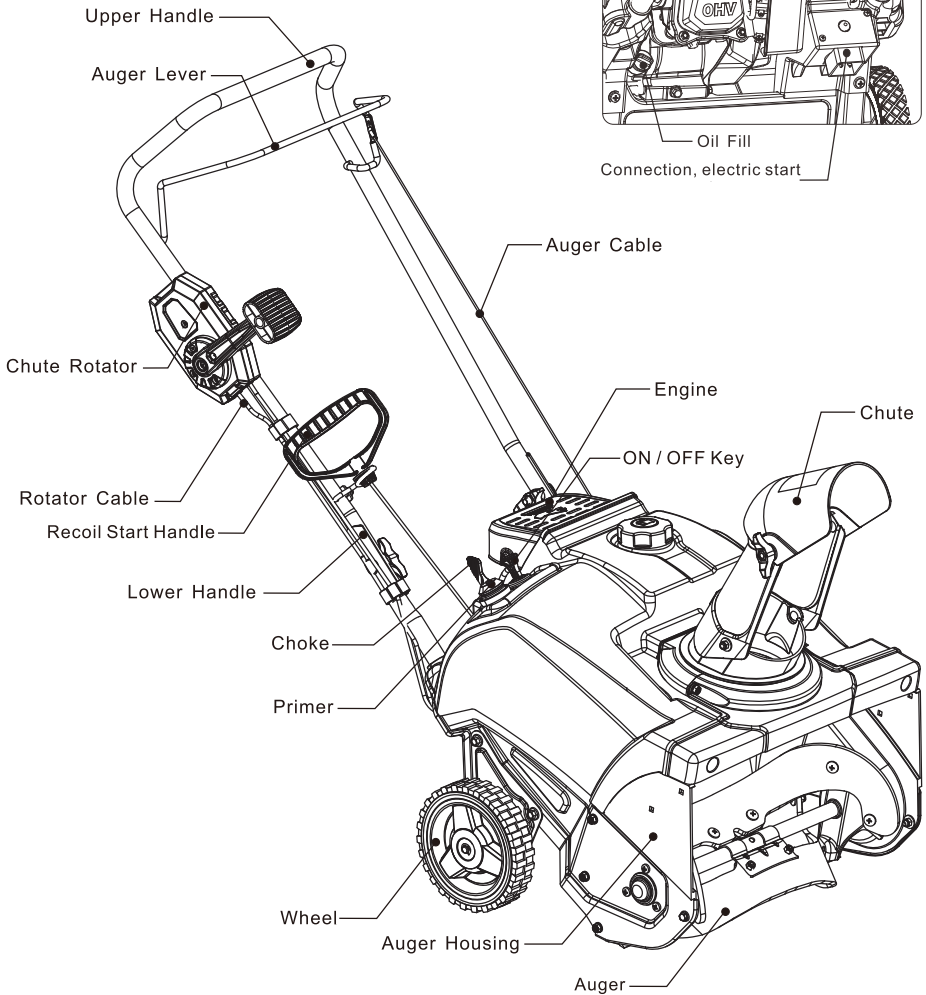
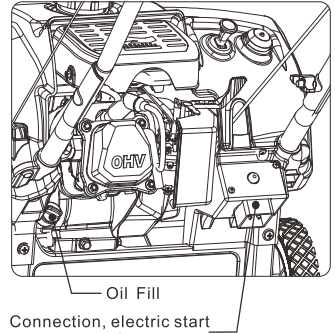

ASSEMBLY

Your snow thrower requires some assembly. This unit ships from our factory without oil. It must be properly serviced with fuel and oil before operation.

If you have any questions regarding the assembly of your snow thrower, call our Technical Support Team at 1-888-676-7909. Please have your serial number and model number available.

UNPACKING

1. Remove any banding and open carton from top.
2. Remove all loose packed items and packaging inserts.
3. Remove all additional loose items from packaging materials. Do not discard packaging until you have confirmed all components are present.

Packing List

Snow Thrower	Knob (2)
Chute Assembly	Cable Retention Clip (2)
Spark Plug Wrench	Square Neck Bolt M6x16 (2)
Funnel	Flat Washer 6 (2)
Motor Oil	Locknut M6 (2)
Extra Key	Bolt M4x40 (2)
Square Neck Bolt M8x55 (2)	Flat Washer 4 (4)
Washer 8 (2)	Locknut M4 (2)

Tools Kit Content: Tools Required

7mm wrench (or adjustable wrench) & Phillips screwdriver to tighten the screws and nuts of the chute rotation handle assembly.

10mm wrench (or adjustable wrench) for tightening the bolts of the chute.

Auger Clutch Cable and Upper Handle Set Up

1. Unwind the Auger Clutch Cable located on the left-hand side of the snow thrower.

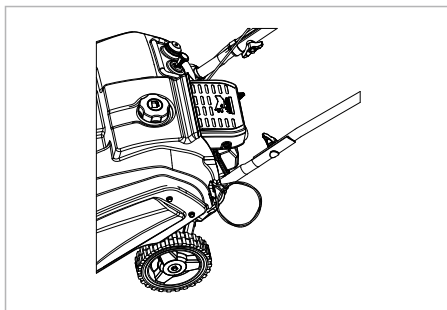

2. Route the z-bend of the cable through the center hole of the Auger Lever.

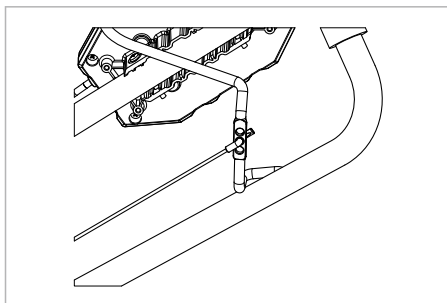

3. Attach the Upper handle to Lower Handle using the square neck bolts (A), curved washer (B) and handle knob (C).

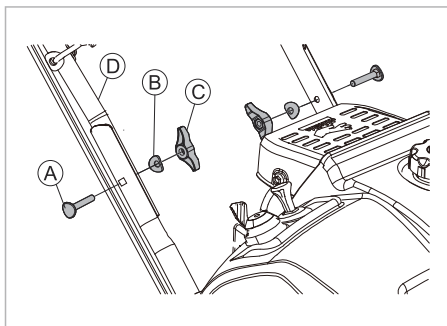

4. Place the recoil start handle into the ring.

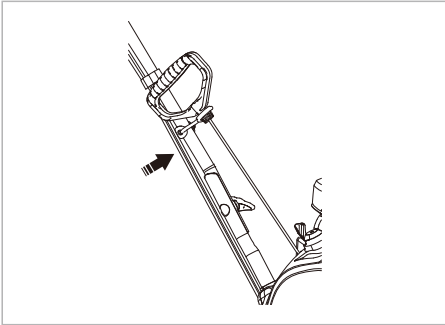

Installing the Discharge Chute and Chute Deflector

1. Place the Discharge Chute Assy (item A) onto the chute base. Note: Align the locating tab on the discharge chute base with the slot on the back of the discharge chute assy.
2. Install two M6 Carriage bolts (Item B) from the inside of the chute outward, placing the washers and M6 locknuts (items C, D) on the outside. Tighten securely.

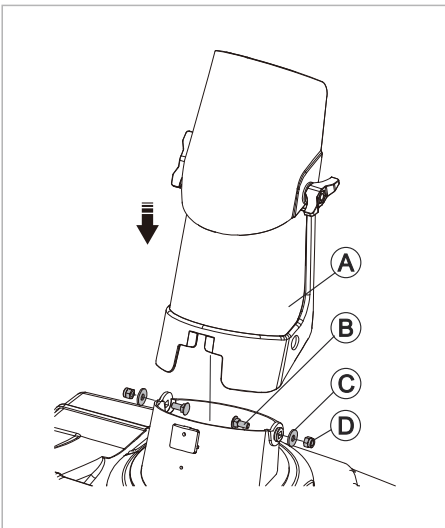

Installing the Chute Rotator

Install the Chute Control Assembly onto the right side of the upper handle using two M4 Phillips head screws (item A), M4 Flat washers (item B) and M4 Lock Nut (item E).

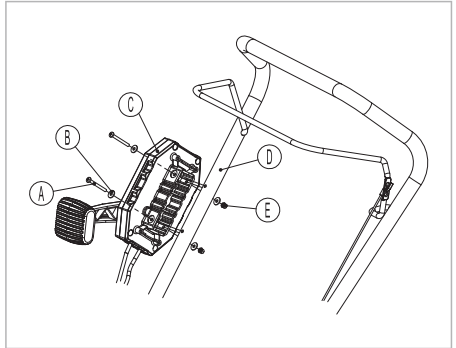

OPERATION

The operation of any snow thrower can result in foreign objects thrown into the eyes, which can result in severe eye damage. Always wear safety glasses or eye shields while operating your snow thrower or performing any adjustments or repairs. We recommend standard safety glasses, or a wide vision safety mask worn over spectacles.

WARNING

Before operating your machine, carefully read and understand all safety, controls and operating instructions in this Operator's Manual.

Failure to follow these instructions can result in serious personal injury.

Introduction

Read this section before you start the engine.

Then, take the time to familiarize yourself with the basic operation of the snow thrower before using it.

Add Fuel

DANGER

Gasoline vapors are highly flammable and extremely explosive.

DO NOT light or smoke cigarettes. Fire or explosion can cause severe burns or death.

Only fill or drain fuel outdoors in a well-ventilated area. **DO NOT** pump gasoline directly into the engine. Use an approved container to transfer the fuel to the engine.

Never use a gasoline container, gasoline tank, or any other fuel item that is broken, cut, torn or damaged.

DO NOT overfill the gasoline tank. Always keep fuel away from sparks, open flames, pilot lights, heat and other sources of ignition.

Use clean, fresh, regular unleaded gasoline with a minimum octane rating of 87 and an ethanol content of 10% or less by volume. **DO NOT** mix oil with gasoline.

1. Remove the fuel tank cap.
2. Slowly add gasoline to the tank. **DO NOT** OVERFILL.

Gasoline can expand after filling. A minimum of $\frac{1}{4}$ in. (6.4 mm) of space left in the tank is required for gasoline expansion although more than $\frac{1}{4}$ in. (6.4 mm) is recommended. Gasoline can be forced out of the tank as a result of expansion if overfilled and can affect the stable running condition of the snow thrower.

CAUTION

DO NOT fill the tank when the engine is running or hot.

NOTE

The engine works well with 10% or less ethanol blended gasoline. When using ethanol-gasoline blends there are some issues worth noting:

Ethanol-gasoline blends can absorb more water than gasoline alone.

These ethanol blends can eventually separate, leaving water or a watery good in the tank, fuel valve and carburetor. The compromised gasoline can be drawn into the carburetor and cause damage to the engine and/or create potential hazards.

If a fuel stabilizer is used, confirm that it is formulated to work with ethanol-gasoline blends.

Any damages or hazards caused by using ethanol blended gasoline higher than 10% by volume, improperly stored gasoline, and/or improperly formulated stabilizers, are not covered by manufacturer's warranty.

It is advisable to always shut off the gasoline supply and run the engine to starvation after each use. See Storage instructions for extended non-use.

NOTE

The recommended oil type is 5W-30 automotive oil.

1. Place the snow thrower on a flat, level surface.
2. Remove oil fill cap/dipstick to add engine oil.
3. Using a funnel, add up to 12 fl.oz (350 ml) of oil and replace oil fill cap/dipstick. DO NOT OVERFILL.
4. Check the engine oil level and add as needed.
5. Securely screw in the oil filler cap/dipstick.

NOTE

Once oil has been added, a visual check should show oil about 1-2 threads from running out of the fill hole.

When using the dipstick to check oil level, DO NOT screw in the dipstick while checking.

Add Engine Oil

CAUTION

This unit ships from our factory without oil.

It must be properly serviced with fuel and oil before operation. DO NOT attempt to crank or start the engine before it has been properly filled with the recommended type and amount of oil.

Damage to the engine as a result of failing to follow these instructions will void your warranty.

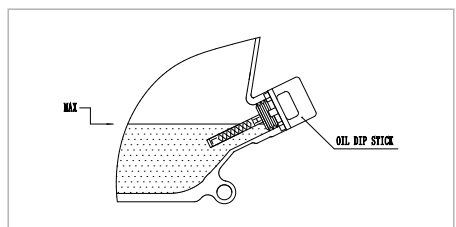
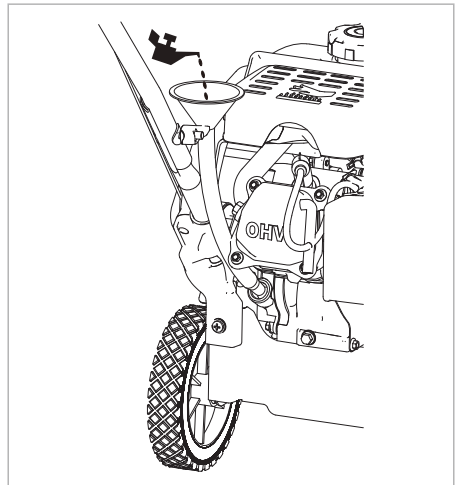

Starting the Engine

1. Check the oil level and add oil if necessary.
2. Release the Auger Lever.
3. Insert the ON/OFF key.

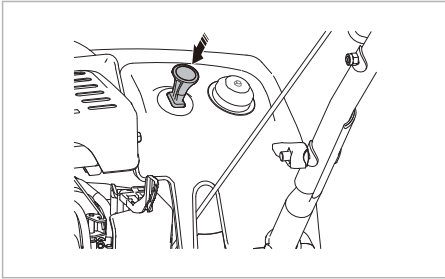

4. Slide the Choke lever to the CLOSED position.

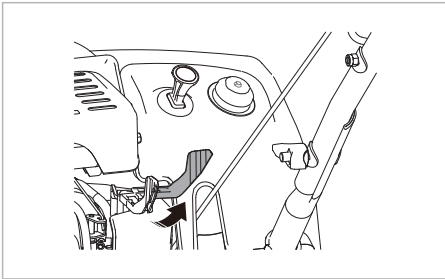

5. Firmly push in the primer 3 times with your thumb, holding the primer in a for a second before releasing it each time.

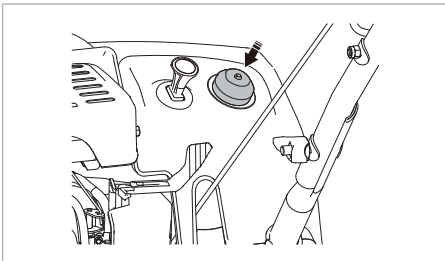

NOTE

It may not be necessary to use the primer or the choke if the engine has been running and is hot.

Excessive priming may flood the engine and prevent it from starting.

6. Pull the starter handle slowly until resistance felt, then pull rapidly.

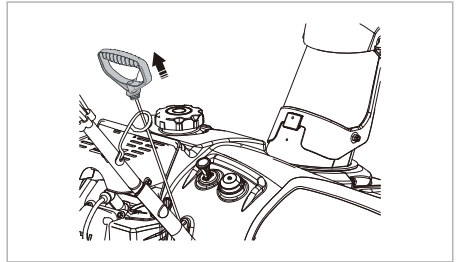

7. Once the engine starts, slide the choke lever to the OPEN position.

Starting the Engine with Electric Start

WARNING

The product has a 120 Volt A.C. electric starter. Do not use the electric starter if your house is not a 120 Volt A.C. three-wire grounded system. Serious personal injury or damage to the product could occur. The electric starter has a three-wire power plug and is designed to use 120 Volt A.C. household current. Ensure that your house is a 120 Volt A.C. three-wire grounded system. If you are uncertain, consult a licensed electrician.

NOTE

Use an extension cord that is recommended for outdoor use, and that is not longer than 50 feet (15 m).

Do the same steps from 1 to 5 of "Starting the Engine" first.

6. Plug a 3-wire extension cord into the electric start adapter on the snow blower. Plug the other end of the power cord into a convenient 120V outlet.

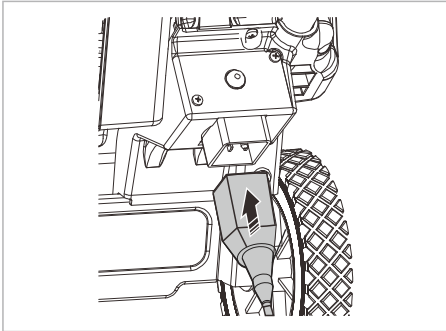

7. Press and hold the start button on the control box for 5 seconds

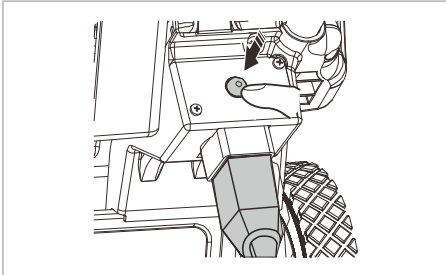

8. If the engine does not start, wait 5 seconds, then push the start button again.
9. Once the engine starts, Slide the choke lever to the OPEN position, remove the extension cord from the unit and unplugging it from the outlet, run the engine 30-40 seconds at idling speed before you start to throw snow.

Stopping the Engine and the snow thrower

To stop the engine

1. Release the Auger Lever.
2. Pull the ON/OFF key out.

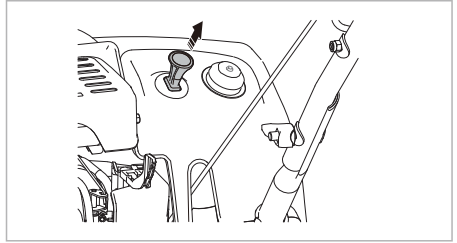

Engaging the Auger Blade

To engage the auger blade, hold the Auger Lever against the upper handle.

Disengaging the Auger Blade

To disengage the auger blade, release the Auger Lever.

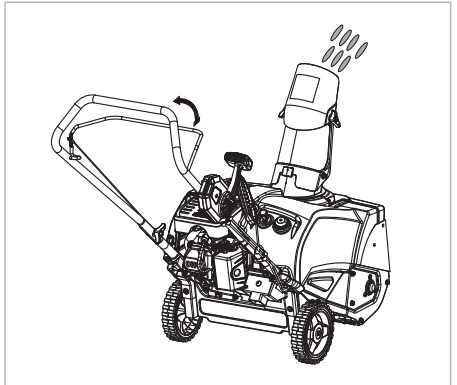

Adjusting the Discharge Chute and Chute Deflector

The direction of the chute deflector is controlled by the chute rotation handle, located on the right side of upper handle.

1. Move the chute rotation handle forward / backward to adjust the discharge chute direction.
2. To adjust snow throwing distance, adjust the chute deflector by loosening the wing nuts on both sides of chute deflector, move the deflector to the desired position and re-tighten the wing nuts.

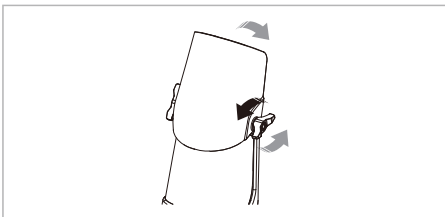
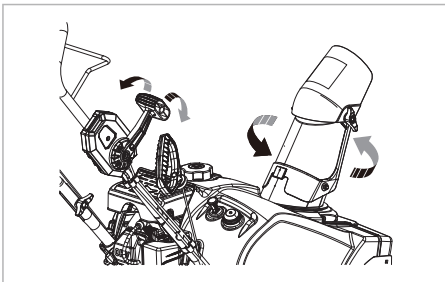

Clearing a Clogged Discharge Chute

▲ DANGER

Hand contact with the rotating auger blades inside the discharge chute is the most common cause of injury associated with snow throwers. Never use your hand to clean out the discharge chute.

To clear the chute:

1. Pull the ON/OFF key out to turn the engine off.
2. Wait 10 seconds to be sure the auger blades have stopped rotating.
3. Always use a clearing tool at least 15 inches long, not your hands.

Preventing Freeze-up after Use

When snow removal is completed, let the engine run for a few minutes to prevent moving parts from freezing. Stop the engine, wait for all moving parts to stop.

1. Clean off any snow and ice from the base of the chute.
2. Rotate the discharge chute left and right to free it from any ice buildup.
3. Remove the ON /OFF key, pull the recoil starter handle several times.

NOTE

In snowy and cold conditions, some controls and moving parts may freeze. Do not use excessive force when trying to operate frozen controls. If you have difficulty operating any control or part, start the engine and let it run for a few minutes.

Operating Tips

1. The best time to remove snow is the early morning. At this time the snow is usually dry and has not been exposed to the direct sun and warming temperatures.
2. Slightly overlap each successive path to ensure all snow will be removed.
3. Throw snow downwind whenever possible.
4. For extremely heavy snow, reduce the width of snow removal by overlapping previous path and moving slowly.
5. Keep the engine clean and clear of snow during use. This will help air flow and extend engine life.
6. After snow-throwing is completed, allow the engine to run for a few minutes to melt snow and ice off the engine.

▲ DANGER

The auger blades can throw stones, toys, and other foreign objects and cause serious personal injury to the operator or to bystanders.

Keep the area to be cleared free of all objects that the auger blades could pick up and throw.

Keep all children and pets away from the area of operation.

Do not operate snow thrower if weather conditions impair visibility. Throwing snow during a heavy, windy snowstorm can blind you and be hazardous to the safe operation of the snow thrower.

MAINTENANCE

Proper maintenance of your unit is important for maximum performance and a long service life.

To help you properly care for your unit, the following section includes a maintenance schedule and simple maintenance procedures. We suggest working with an Authorized Dealer, professional or qualified mechanic for any service which you are unfamiliar with, not mechanically proficient with or possessing the proper tools.

The maintenance schedule provided applies to normal operating conditions. If your unit is operated under more severe conditions such as high-temperatures, sustained high-load or operation in dusty or unusually wet conditions, please inspect and service your unit more frequently.

DANGER

DO NOT use gasoline or low flash point solvents to clean the engine or any of its components. The possibility exists of fire or explosion which can damage the equipment and cause severe bodily harm or even DEATH.

WARNING

Some maintenance operations may require a running engine. ALWAYS make sure the maintenance area is well ventilated. Gasoline engine exhaust contains poisonous carbon monoxide gas that can cause headaches, nausea, dizziness, drowsiness, confusion, fainting or death.

CAUTION

ALWAYS allow the engine to cool before servicing. NEVER attempt to service a hot engine.

CAUTION

ALWAYS disconnect the spark plug wire from the spark plug before performing maintenance or adjustments.

Failure to follow these instructions can result in serious personal injury or property damage.

NOTE

Maintenance, replacement, or repair of emission control devices and systems may be performed by any non-road engine repair establishment or individual.

RECOMMENDED MAINTENANCE SCHEDULE

Recommended Maintenance Schedule		Each Use	First 20 Hours or 1 Month	Every 50 Hours or 3 Months	Every 100 Hours or Every Season	Every 300 Hours	Before Storage
Engine Oil	Check	X					
	Replace		X		X (1)		
Spark Plug	Check		X		X		
	Replace				X	X	
Fuel	Check Level	X					
	Drain						X
Fuel Lines	Check				X		X
	Replace					X	
Hardware-Bolts/Nuts Carburetor	Check		X		X		
	Drain						X
Air Cooling System	Check				X		
Valve Clearance	Check-Adjust					X (2)	

1. Service more frequently when used in dusty conditions.
2. These items should be maintained and repaired by an authorized dealer, unless the owner has appropriate tools and is proficient with mechanical maintenance.

Oil Change

NOTE

Used oil is a hazardous waste product and must be disposed of properly. Check your local regulations for proper disposal/recycling facilities.

Change the engine oil after the first 20 hours of use. Thereafter, change the oil every 100 hours of use or every season. Change the oil more often if used in dusty conditions.

If possible, drain the oil while the engine is warm. Warm oil drains more quickly and completely. Refer to the adding engine oil section for the recommended oil for your operating environment.

1. Place a suitable container below the oil drain plug to catch the used oil.
2. Remove the oil filler cap/dipstick and the drain plug bolt and sealing washer from the engine.
3. Allow the oil to drain completely from the engine.
4. Reinstall and tighten the drain plug bolt with sealing washer.
5. Using a funnel, add up to 12 oz (0.35L) of oil to the engine.
6. Check the oil level using the dipstick. DO NOT screw in when checking.
7. When finished screw in the dipstick / oil fill cap securely.

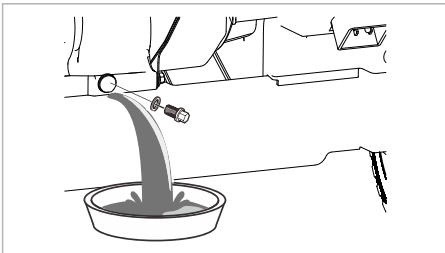

Spark Plug Service

Check the spark plug after the first 20 hours and every 100 hours of operation thereafter. Replace the spark plug after 300 hours of operation.

Recommended Spark Plug: Torch E5RTC or NGK BR5HS.

Spark Plug Gap: .028 - .030 in. (0.7-0.8mm)

CAUTION

Always allow the engine to cool before performing maintenance, adjustments or service.

NOTE

A loose spark plug can overheat and damage the engine.

1. Remove the spark plug cap and clear away any dirt around the spark plug base.
2. Using a spark plug wrench, remove the spark plug.
3. Visually check the spark plug. Clean with a steel brush. If the insulator is damaged, replace the spark plug.
4. Measure the spark plug gap with a suitable gauge. Adjust the spark plug gap as necessary by carefully bending the ground electrode.
5. To prevent cross threading, thread the spark plug in by hand until it seats, then tighten with a spark plug wrench as follows.

New Spark Plug - Tighten $\frac{1}{2}$ turn after the plug seats to the cylinder head.

Used Spark Plug - Tighten to $\frac{1}{4}$ turn after the plug seats to the cylinder head.

6. Reconnect the spark plug cap.

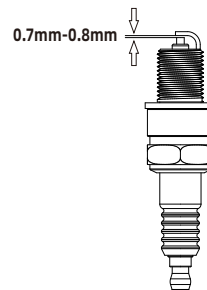

NOTE

The spark plug must be tightened securely, or it may become very hot and damage the engine.

STORAGE

Immediately prepare your snow thrower for storage at the end of the season or if the unit will not be used for 30 days or more.

WARNING

Never store the snow thrower with gasoline in the tank and carburetor inside a building where fumes may reach an open flame, spark or pilot light as on a furnace, water heater, clothes dryer or gas appliance. Allow the engine to cool before storing in any enclosure.

When snow thrower is to be stored for a period of time, clean it thoroughly, remove all dirt, grease, leaves, etc. Store in a clean, dry area.

1. Clean the entire snow thrower after each use.
2. Be sure that all nuts, bolts and screws are securely fastened. Inspect moving parts for damage, breakage and wear. Replace if necessary.

FUEL SYSTEM

IMPORTANT: It is important to prevent gum deposits from forming in essential fuel system parts such as carburetor, fuel hose, or tank during storage. Also, alcohol blended fuels can attract moisture which leads to separation and formation of acids during storage. Acidic gas can damage the fuel system of an engine while in storage.

Empty the fuel tank by starting the engine and letting it run until the fuel lines and carburetor are empty.

Never use engine or carburetor cleaner products in the fuel tank or permanent damage may occur.

Use fresh fuel next season.

NOTE

Fuel stabilizers are an acceptable alternative in minimizing the formation of fuel gum deposits during storage.

Add stabilizer to gasoline in fuel tank or storage container. Always follow the mix ratio found on stabilizer container. Run the engine at least 10 minutes after adding stabilizer to allow the stabilizer to reach the carburetor. Do not empty the gas tank and carburetor if using fuel stabilizer.

ENGINE OIL

Drain oil (with engine warm) and replace with clean engine oil.

CYLINDER

1. Remove spark plug.
2. Pour approximately one teaspoon of clean engine oil (5 cc) into the spark plug hole.
3. Pull recoil starter handle slowly a few times to distribute oil.
4. Reinstall and tighten spark plug.

OTHER

Remove the ON/OFF key; store it in a safe place.

Do not store gasoline from one season to another.

Replace your gasoline can if the can starts to rust. Rust and / or dirt in your gasoline will cause problems.

If possible, cover it to protect it from dust and dirt.

Cover your snow thrower with a suitable protective cover that does not retain moisture. Do not use plastic. Plastic cannot breathe, which allows condensation to form and will cause your snow thrower to rust.

IMPORTANT: Never cover snow thrower while engine / exhaust area is still warm.

TROUBLESHOOTING

Problem	Cause	Solution
Does not start	Safety ignition key is not inserted.	Insert safety ignition key.
	Out of fuel.	Fill fuel tank with fresh, clean gasoline.
	Choke in OPEN position.	Move to CLOSED position.
	Primer not depressed.	Prime as instructed in the Operation section of this manual.
	Engine is flooded.	Wait a few minutes before restarting, DO NOT prime.
	Spark plug wire is disconnected.	Connect wire to spark plug.
	Bad spark plug.	Replace spark plug.
	Stale fuel.	Empty fuel tank & carburetor, refill with fresh, clean gasoline.
Loss of power	Water in fuel.	Empty fuel tank & carburetor, refill with fresh, clean gasoline.
	Spark plug wire loose.	Reconnect spark plug wire.
	Throwing too much snow.	Reduce speed and width of swath.
	Fuel tank cap is covered with ice or snow.	Remove ice and snow on and around fuel tank cap.
	Stale / Old Fuel.	Drain and fill with fresh fuel.
Engine idles or runs roughly	Blocked carburetor air intake.	Clear blockage (ensure engine is cool).
	Choke is in CLOSED position.	Move choke to OPEN position.
	Blockage in fuel line.	Clean fuel line.
	Stale fuel.	Empty fuel tank & carburetor, refill with fresh, clean gasoline.
	Water in fuel.	Empty fuel tank & carburetor, refill with fresh, clean gasoline.
Loss of snow discharge or slowing of snow discharge	Fuel filter clogged, Carburetor malfunction, ignition malfunction.	Have unit serviced by Outdoor Power Service Center.
	Auger v-belt is off of pulley.	Check / reinstall auger v-belt.
	Auger v-belt is worn.	Check / replace auger v-belt.
	Blockage from Chute.	Clean snow chute.
Chute Rotation lever is difficult to operate	Auger jammed.	Remove debris or foreign object from auger.
	Frozen components.	Move to warmer location and allow to thaw out.
	Cable are kinked or damaged.	Ensure cables are not kinked. Replace damaged cables.

If engine still doesn't start, contact our Technical Support Team at 1-888-676-7909 Mon-Fri 8-4 CST or Email: support@poulanpro-power.us

BASIC SERVICE PARTS LIST**Common Service Parts**

Service Part	Part Number
Auger Paddle	2714100004-0001
Auger Belt 3LXA827	2126500005-0001
Wheel	2803100008-0005
Auger Cable	3001700040-0001
Scraper	2706100005-0001
Bolt - Auger Paddle	3611300004-0001
Nut - Auger Paddle Bolt	360120005
Spark Plug	2204700004-0001
Recoil Starter	2000200074-0001
Oil Dipstick	1101500001-0001
Engine Switch	2205000006-0001
Carburetor	1807900098-0001
Fuel Tank Cap	1800900044-0001
Fuel Line	1816200008-0001
Ignition Coil	2204100067-0001
Oil Drain Bolt	360290002
Oil Drain Bolt - Washer	3412100041-0001

WARRANTY STATEMENT

2-Year Limited Warranty Terms and Conditions

PoulanPro® is a registered trademark of Husqvarna AB and is used under license to Novus Performance Products LLC. Novus products are warranted for two (2) years against defects in materials or workmanship when put to ordinary and normal consumer use.

For the purposes of all the above warranties, "ordinary and normal consumer use" refers to non-commercial residential use and does not include misuse, accidents or damage due to inadequate maintenance. Novus Performance Products LLC certifies that Novus Products are fit for ordinary purposes for which a product of this type is used. Novus Performance Products LLC, however, limits the implied warranties of merchantability and fitness in duration to a period of two (2) years in consumer use, ninety (90) days for any other use.

The 2-Year Limited Warranty on Novus Products starts on the purchase date. The 2-Year Limited Warranty is applicable only to the original owner.

The warranty holder is responsible for the performance of the required maintenance as defined by the manufacturer's owner's manuals. The warranty holder is responsible for replacement of normally wearing parts such as the Belt, Shear Pins, Spark Plug and Air Filter. Accessories to the machine are not covered by this warranty.

During the warranty period, the warranty holder is responsible for the machine transportation charges, if required.

During the warranty period, warranty parts will be shipped by standard method at no charge to the warranty holder. Expedited shipping of warranty parts is the responsibility of the warranty holder.

SOME STATES DO NOT ALLOW LIMITATIONS ON THE LENGTH OF IMPLIED WARRANTIES, SO THE ABOVE LIMITATIONS MAY NOT APPLY TO YOU.

Novus Performance Products LLC shall not be liable under any circumstances for any incidental or consequential damages or expenses of any kind, including, but not limited to, cost of equipment rentals, loss of profit, or cost of hiring services to perform tasks normally performed by Novus Products.

SOME STATES DO NOT ALLOW THE EXCLUSION OR LIMITATION OF INCIDENTAL OR CONSEQUENTIAL DAMAGES, SO THE ABOVE LIMITATIONS MAY NOT APPLY TO YOU.

THIS WARRANTY GIVES YOU SPECIFIC LEGAL RIGHTS, AND YOU ALSO HAVE OTHER RIGHTS, WHICH VARY FROM STATE TO STATE.

Technical Support:

Toll free: 1-888-676-7909 Mon-Fri 8-4 CST

Email: support@poulanpro-power.us

U.S. FEDERAL EMISSION CONTROL WARRANTY STATEMENT YOUR WARRANTY RIGHTS AND OBLIGATIONS

The United States Environmental Protection Agency and Novus Performance Products LLC (Novus) are pleased to explain the emissions control system warranty on your 2024-2025 small off-road engine/equipment (SORE). In the United States, new equipment that use small off-road engines must be designed, built, and equipped to meet the State's stringent anti-smog standards. Novus must warrant the emissions control system on your small off-road engine/equipment for the periods of time listed below there has been no abuse, neglect or improper maintenance of your small off-road engine or equipment leading to the failure of the emissions control system.

Your emissions control system may include parts such as the carburetor or fuel-injection system, the ignition system, catalytic converter, fuel tanks, fuel lines (for liquid fuel and fuel vapors), fuel caps, valves, canisters, filters, clamps and other associated components. Also included may be hoses, belts, connectors, and other emission-related assemblies.

Where a warrantable condition exists, Novus will repair your small off-road engine/equipment at no cost to you including diagnosis, parts and labor.

MANUFACTURER'S WARRANTY COVERAGE:

This emissions control system on your small off-road engine/equipment is warranted for two years. If any emission-related part on your small off-road engine/equipment is defective, the part will be repaired or replaced by Novus.

OWNER'S WARRANTY RESPONSIBILITIES:

As the small off-road engine/equipment owner, you are responsible for the performance of the required maintenance listed in your owner's manual. Novus recommends that you retain all receipts covering maintenance on your small off-road engine/equipment, but Novus cannot deny warranty coverage solely for the lack of receipts or for your failure to ensure the performance of all scheduled maintenance.

As the small off-road engine/equipment owner, you should however be aware that Novus may deny you warranty coverage if your small off-road engine/equipment or a part has failed due to abuse, neglect, or improper maintenance or unapproved modifications.

You are responsible for presenting your small off-road engine/equipment to a Novus distribution center or service center as soon as the problem exists. The warranty repairs shall be completed in a reasonable amount of time, not to exceed 30 days. If you have any questions regarding your warranty rights and responsibilities, you should contact:

Novus Performance Products LLC
customer service representative
1-800-409-7802
Email: Support@novuspowerequipment.com

DEFECTS WARRANTY REQUIREMENTS

(a) Applicability. This section applies to emissions control systems on small off-road engines or equipment that use small off- road engines subject to the emission standards in this Article. The warranty period begins on the date the engine or equipment is delivered to an ultimate purchaser and extends for a period of two years.

(b) General Emissions Warranty Coverage. The engine or equipment must be warranted to the ultimate purchaser and any subsequent owner that the emissions control system when installed was:

- (1) Designed, built, and equipped so as to conform with all applicable regulations; and
- (2) Free from defects in materials and workmanship that causes the failure of a warranted part for a period of two years.

(c) The warranty on emissions-related parts will be interpreted as follows:

- (1) Any warranted part that is not scheduled for replacement as required maintenance in the written instructions required by subsection (e) must be warranted for the warranty period defined in subsection (b)(2). If any such part fail during the period of warranty coverage, it must be repaired or replaced by Novus or it's contracted warranty provider according to subsection (4) below. Any such part repaired or replaced under the warranty must be warranted for a time not less than the remaining warranty period.
- (2) Any warranted part that is scheduled only for regular inspection in the written instructions required by subsection (e) must be warranted for the warranty period defined in subsection (b)(2). A statement in such written instructions to the effect of "repair or replace as necessary" shall advise owners of the warranty coverage for emissions related parts. Replacement within the warranty period is covered by the warranty and will not reduce the period of warranty coverage. Any such part repaired or replaced under warranty must be warranted for a time not less than the remaining warranty period.
- (3) Any warranted part that is scheduled for replacement as required maintenance in the written instructions required by subsection (e) must be warranted for the period of time prior to the first scheduled replacement point for that part. If the part fails prior to the first scheduled replacement, the part must be repaired or replaced by Novus according to Subsection (4) below. Any such part repaired or replaced under warranty must be warranted for a

time not less than the remainder of the period prior to the first scheduled replacement point for the part.

- (4) Repair or replacement of any warranted part under the warranty provisions of this article must be performed at no charge to the owner at a warranty station.
- (5) Notwithstanding the provisions of subsection (4) above, warranty services or repairs must be provided at distribution centers that are franchised to service the subject small off-road engine/equipment.
- (6) The small off-road engine/equipment owner must not be charged for diagnostic labor that leads to the determination that a warranted part is in fact defective, provided that such diagnostic work is performed at a warranty station.
- (7) Throughout the emissions control system's warranty period set out in subsection (b)(2), Novus or it's contracted warranty provider must maintain a supply of warranted parts sufficient to meet the expected demand for such parts and must obtain additional parts if that supply is exhausted.
- (8) Manufacturer-approved replacement parts that do not increase the exhaust or emissions of the engine or emissions control system must be used in the performance of any warranty maintenance or repairs and must be provided without charge to the owner. Such use will not reduce the warranty obligations of Novus or it's contracted warranty provider.
- (9) The use of add-on or modified parts may be grounds for disallowing a warranty claim made in accordance with this Article. Novus or it's contracted warranty provider will not be liable under this Article to warrant failures of warranted parts caused by the use of an add-on or modified part.
- (10) Novus shall provide any documents that describe that it's warranty procedures or policies within five working days of request by the Executive Officer.
- (d) A list of all emissions warranty parts must be included with each new engine or equipment subject to this Article. The emissions warranty parts list shall include all parts whose failure would increase exhaust and evaporative emissions, and contains the following parts:
 - EMISSIONS PARTS LIST**
 - Exhaust Emission**
 - (1) Fuel Metering System
 - (A) Carburetor and internal parts (and/or pressure regulator or fuel injection system).

(B) Air/fuel ratio feedback and control system.

(C) Cold start enrichment system.

(2) Air Induction System

(A) Controlled hot air intake system.

(B) Intake manifold.

(C) Air filter.

(3) Ignition System

(A) Spark Plugs.

(B) Magneto or electronic ignition system.

(C) Spark advance/retard system.

(4) Exhaust Gas Recirculation (EGR) System

(A) EGR valve body, and carburetor spacer if applicable.

(B) EGR rate feedback and control system.

(5) Air injection System

(A) Air pump or pulse valve.

(B) Valves affecting distribution of flow.

(C) Distribution manifold.

(6) Catalyst or Thermal Reactor System

(A) Catalytic converter.

(B) Thermal reactor.

(C) Exhaust manifold.

(7) Particulate Controls

(A) Traps, filters, precipitators, and any other device used to capture particulate emissions.

(8) Miscellaneous items Used in Above Systems

(A) Vacuum, temperature, and time sensitive valves and switches.

(B) Electronic controls.

(C) Hoses, belts, connectors, and assemblies.

Evaporative Emission

(1) Fuel Tank

(2) Fuel Cap

(3) Fuel lines(for liquid fuel and fuel vapors)

(4) Fuel Line Fittings

(5) Clamps

(6) Pressure Relief Valves

(7) Control Valves

(8) Control Solenoids

(9) Electronic Controls

(10) Vacuum Control Diaphragms

(11) Control Cables

(12) Control Linkages

(13) Purge Valves

(14) Gaskets

(15) Liquid/Vapor Separator

(16) Carbon Canister

(17) Canister Mounting Brackets

(18) Carburetor Purge Port Connector

Note: As they relate to the emissions control system.

(e)Written instructions for the maintenance and use of the emissions control system by the owner shall be furnished with each new engine or equipment subject to this Article. The instructions must be consistent with this Article and applicable regulations contained herein.

(f)The documents required by subsections (d) and (e) must be submitted with the application for emissions control system certification for approval by the Executive Officer. Approval by the Executive Officer of the documents required by subsections (d) and (e) is a condition of certification. The Executive Officer will approve or disapprove the documents required by subsections (d) and (e) within 90 days of the date such documents are received.

(g)The application for emissions control system certification must also include a statement regarding the maintenance of the emissions control system. The statement must include, but not be limited to, information on emissions control system maintenance, and a maintenance schedule.

(h)Any other warranty statements applicable to engines or equipment units must not imply a limitation on the emissions warranty period or its applicability to subsequent owners after the ultimate purchaser. If the warranty period for any warranty other than the emissions warranty is less than two years, the statement of such warranty must specifically state that it does not limit the emissions warranty period of two years from purchase. If any warranty other than the emissions warranty does not extend to subsequent owners after the ultimate purchaser, the statement of such warranty must specifically state that it does not affect the applicability of the emissions warranty to subsequent owners after the ultimate purchaser.