

ASSEMBLY INSTRUCTION

N752P348511



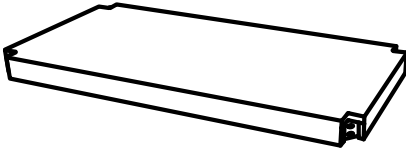
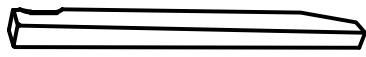

ATTENTION:

1. Check to ensure all parts and hardware are present.
2. We have provided Extra Hardware of A/B/C in case of any bolts missing in the boxes.
3. Do not fully tighten all bolts until all parts are in place. Failure to follow these instructions may cause the bolt to misalign during assembly.

Part List





1	2
	
Table Top x 1pc	Leg x 4pcs

Hardware

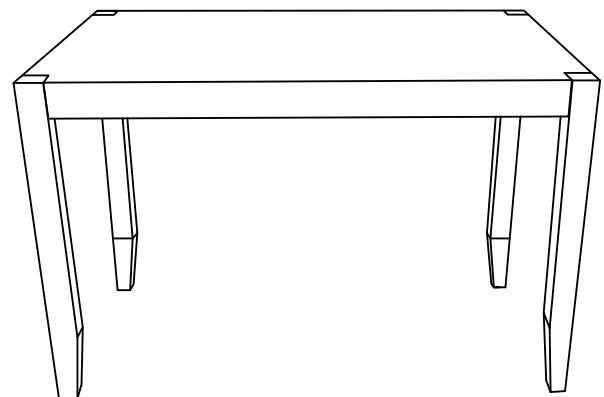
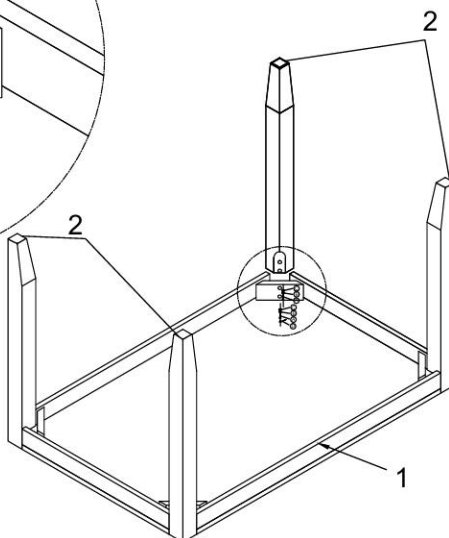
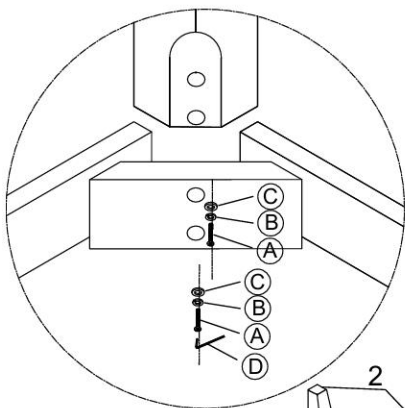
A	B	C	D
			
Ø5/16x60mm	Ø5/16x13mm	Ø5/16x19x2mm	4mm
BOLT (8PCS)	LOCK WASHER (8PCS)	FLAT WASHER (8PCS)	ALLEN KEY (1PC)

Step 1



A		8PCS
B		8PCS
C		8PCS
D		1PC

ASSEMBLY INSTRUCTION

N752P348512





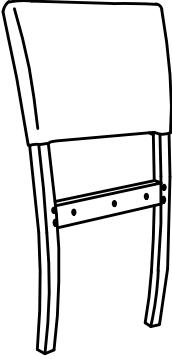
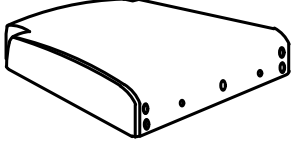
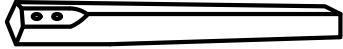

ATTENTION:

1. Check to ensure all parts and hardware are present.
2. We have provided Extra Hardware of A/B/C/D/E/F in case of any bolts missing in the boxes.
3. Do not fully tighten all bolts until all parts are in place. Failure to follow these instructions may cause the bolt to misalign during assembly.

Part List

<p>1</p> 	<p>2</p> 	<p>3</p> 
<p>Chair Back x 1pc</p>	<p>Seat Cushion x 1pc</p>	<p>Front Leg x 2pcs</p>

Hardware

<p>A</p>  <p>Ø10*30mm</p>	<p>B</p>  <p>Ø1/4x38mm</p>	<p>C</p>  <p>Ø1/4x60mm</p>	<p>D</p>  <p>Ø1/4x75mm</p>
<p>WOOD DOWEL (1PC)</p>	<p>SHORT BOLT (2PCS)</p>	<p>BOLT (4PCS)</p>	<p>LONG BOLT (4PCS)</p>
<p>E</p>  <p>Ø1/4x13mm</p>	<p>F</p>  <p>Ø1/4x19x2mm</p>	<p>G</p>  <p>4mm</p>	
<p>LOCK WASHER (10PCS)</p>	<p>FLAT WASHER (10PCS)</p>	<p>ALLEN KEY (1PC)</p>	



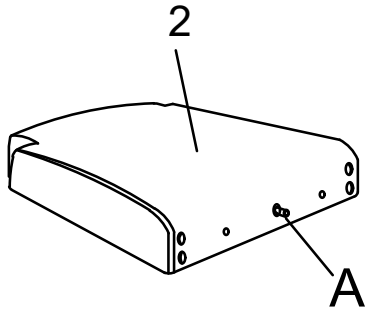

Step 1

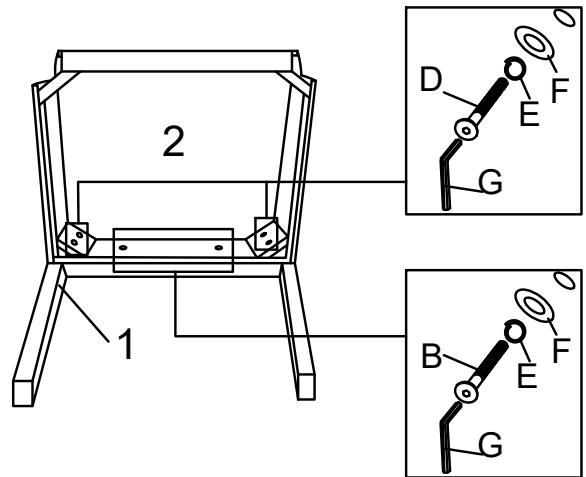

A  1PC





Step 2

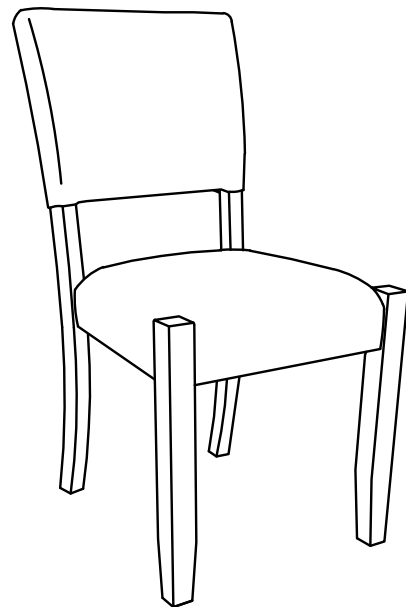
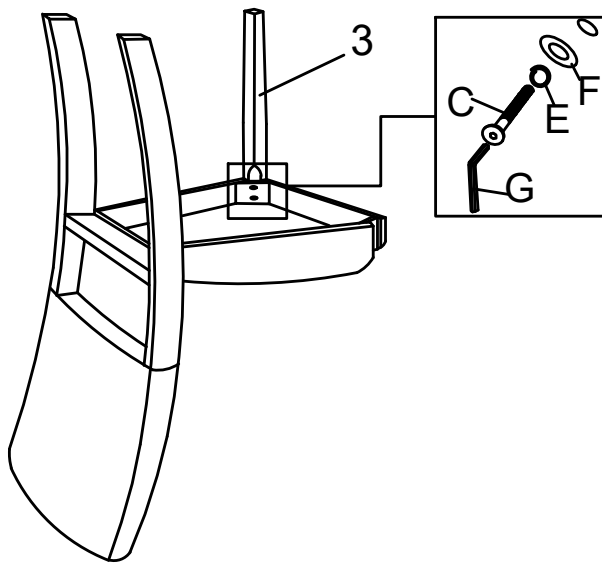

- B  2PCS
- D  4PCS
- E  6PCS
- F  6PCS
- G  1PC

Step 3



- C  4PCS
- E  4PCS
- F  4PCS
- G  1PC