

**CK886200TX**

**TERRARIUM END TABLE**

**Assembly Instructions**



**Southern**  
ENTERPRISES

For assistance with assembly contact:  
Southern Enterprises Inc.  
Customer Service 1-800-633-5096  
service@seidal.com  
www.seidal.com

PO:13009

Top supports up to lb.

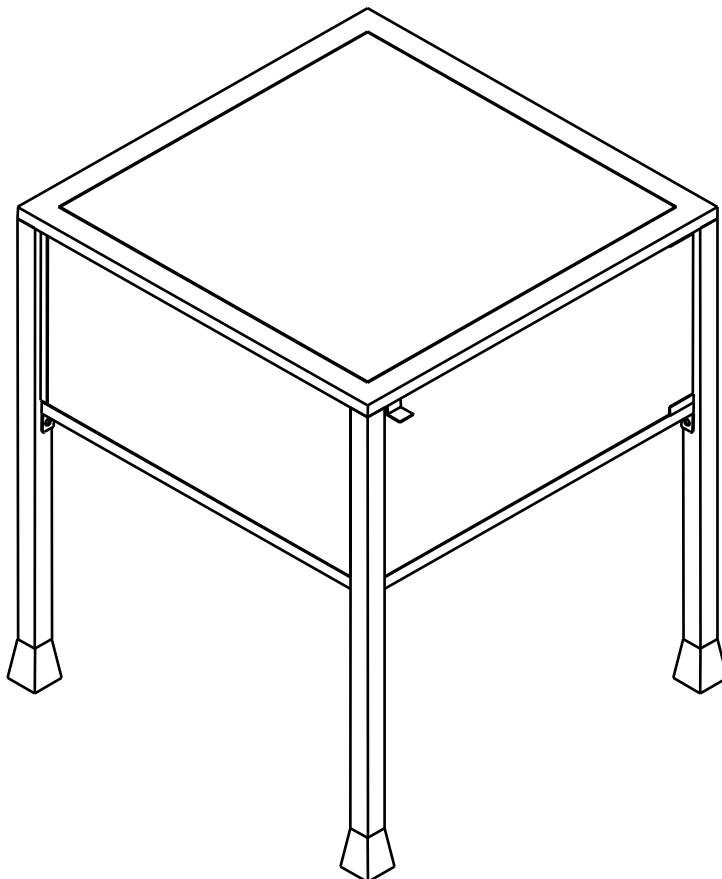

# CK886200TX

## TERRARIUM END TABLE







### Parts List

Please review all parts and hardware before disposing of any packaging.

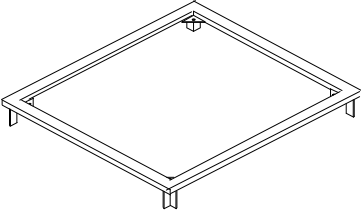
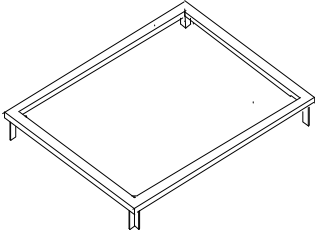
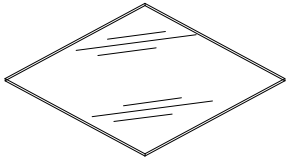
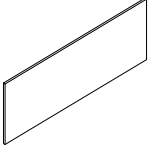
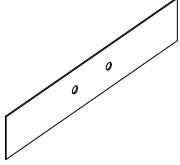
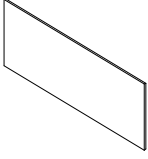
Call Customer Service if missing hardware.

Carefully study the diagrams below.

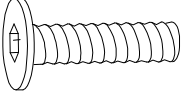
You may receive extra hardware with your unit.

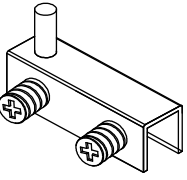
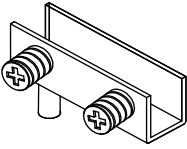
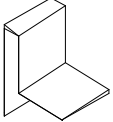
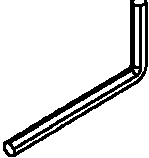
1	1PC	2	1PC	3	1PC
					
top frame		bottom shelf		glass top	
4	1PC	5	1PC	6	2PCS
					
glass door		glass back panel		glass side panel	
7	1PC	8	1PC	9	2PCS
					
right front leg		left front leg		rear leg	
A	12PCS	B	8PCS	C	4PCS
					
bolt 1/4"x1/2"		flat washer		glass pad	
D	2PCS	E	2PCS	F	1PC
					
door hinge w/ screws (TOP)		door hinge w/ screws (BOTTOM)		handle	
				G	1PC
					
				wrench	

#### Care and Cleaning Instructions:

Before using, wipe with a clean, dry cloth.  
Avoid rubbing or scratching the surface with rough or abrasive objects.

For replacement parts or questions, please  
Call Customer Service at 1-800-633-5096.

**Assembly Tool Required**

**No.2 Phillips Screwdriver**

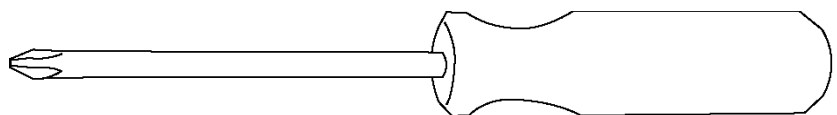

# CK886200TX

## TERRARIUM END TABLE

### Assembly Instructions

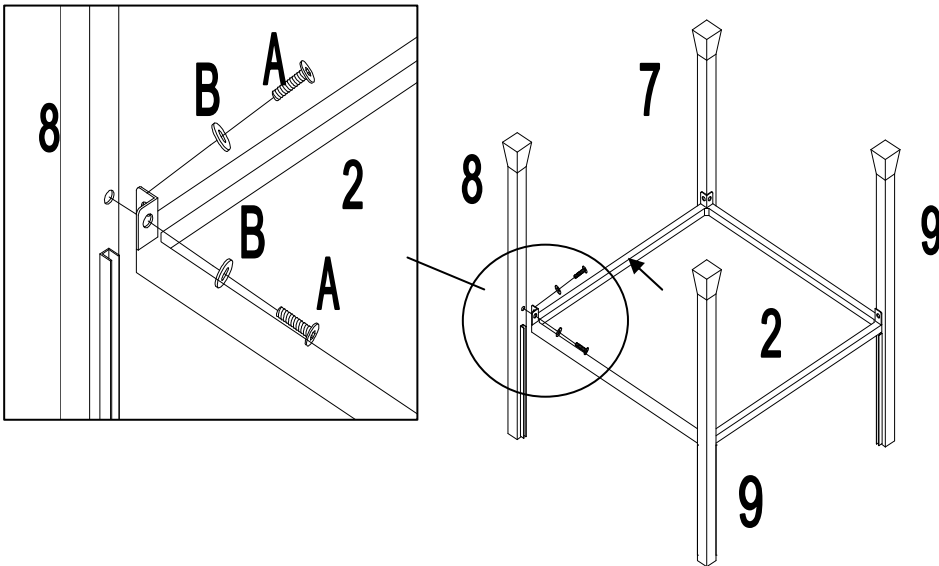

Tip: Do not tighten bolts completely until all the bolts are in place.

Attach right front leg (7), left front leg (8), and rear legs (9) to bottom shelf (2) using bolts (A) and flat washers (B) as shown.

Figure 1

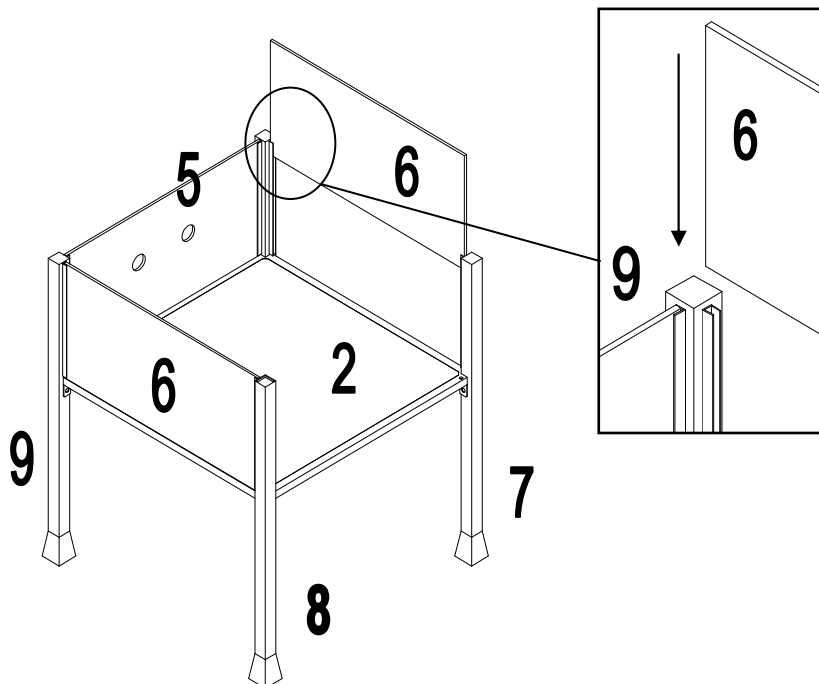

Turn the assembled unit upright. Insert glass back panel (5) and glass side panel (6) along the grooves of the legs as shown.

Figure 2

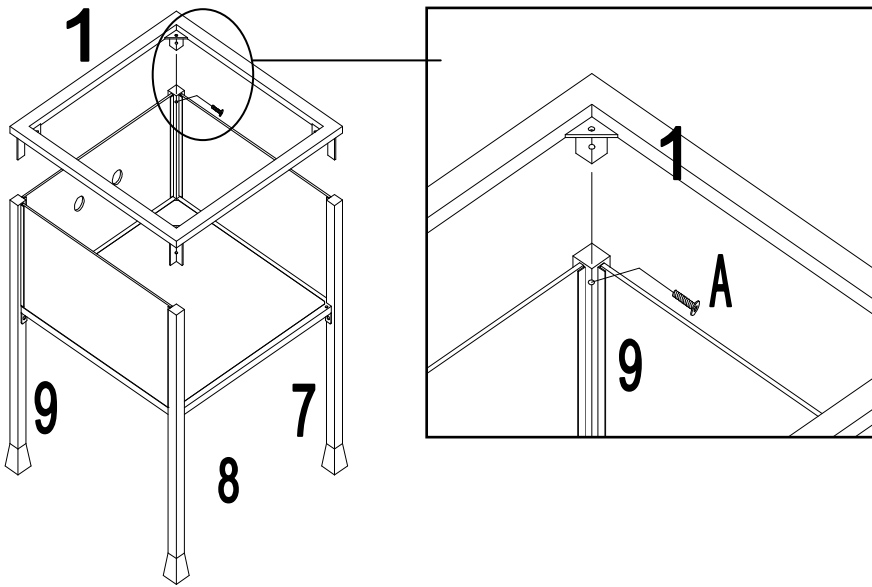

**Step 3:**

Attach top frame (1) to the assembled parts using bolts (A).

**Figure 3**

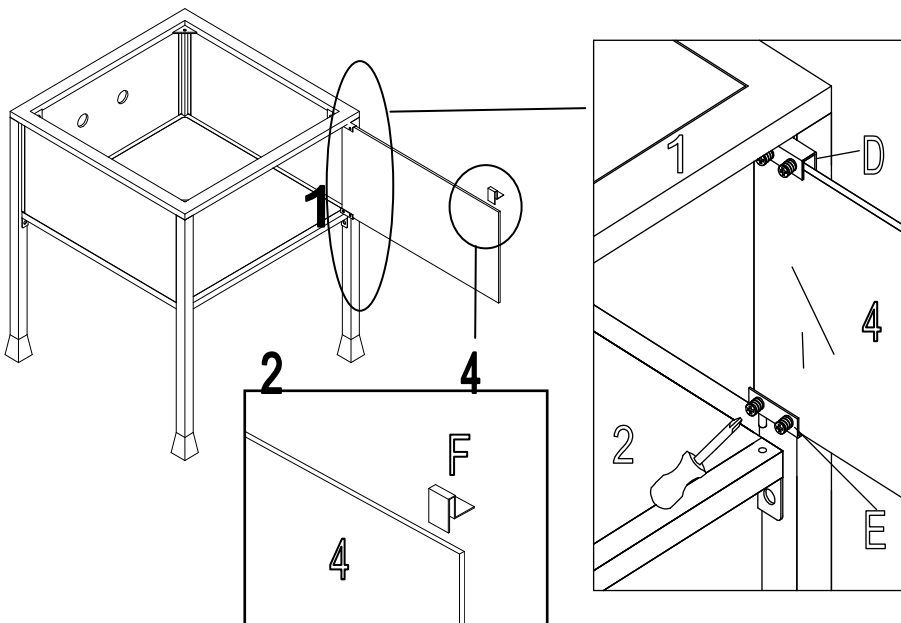

Install glass door (4) to the assembled unit using top door hinge (D) and bottom door hinge (E).

Tighten the bolts on the hinge once the glass is in place. Then, place handle (F) onto the glass door (4) as shown.

**Tip:** Do not over tighten the bolts when securing the glass on the door; it may cause the glass to break.

**Figure 4**

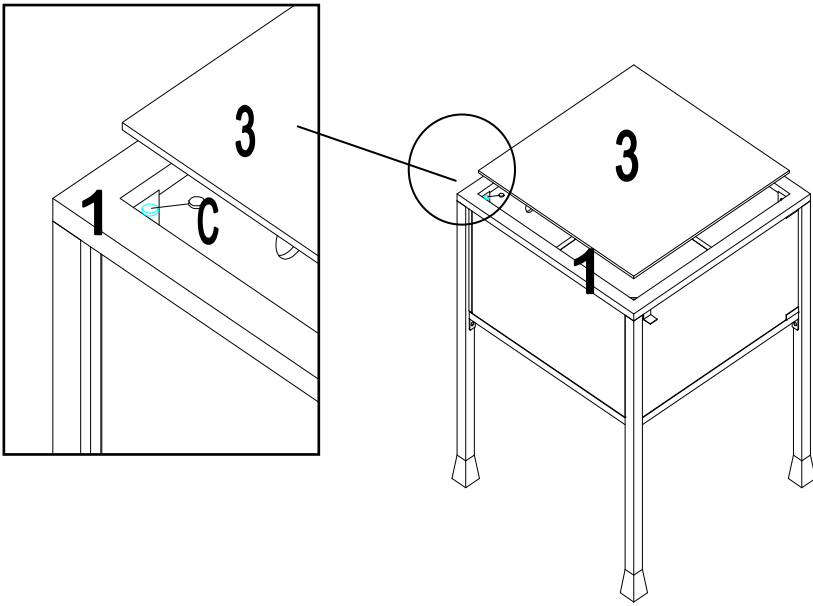

Stick glass pad (C) to bracket on top frame (1).

Then, put glass top (3) onto top frame (1) as shown.

Your terrarium end table is now complete.

Figure 5



**Southern**  
ENTERPRISES

Customer Service 1-800-633-5096  
[service@seidal.com](mailto:service@seidal.com)  
Southern Enterprises, Inc.  
600 Freeport Parkway, Suite 200  
Coppell, Texas 75019

## Parts Replacement Form

### Customer Information

Name \_\_\_\_\_

Address \_\_\_\_\_

City/State/Zip Code \_\_\_\_\_

Phone Number \_\_\_\_\_

Please indicate where you purchased this item: Store/Website/Catalog  
\_\_\_\_\_

Please indicate color/size/style number:  
\_\_\_\_\_

Style No	Parts Letter	Parts Description	Quantity Needed
_____	_____	_____	_____
_____	_____	_____	_____
_____	_____	_____	_____

Please immediately examine this product carefully. Any request for missing parts or damage replacement must be received within 90 days of your receipt of the product. Replacement, if available, will be honored within this time frame. Parts will not be available for items arriving fully assembled. We do not recommend modifying product(s) and we are not responsible for any damages due to product modification(s). If damages or missing parts are not reported within 90 days of your receipt, we are under no obligation to provide parts or replacement merchandise.

Please contact Southern Enterprises at 800-633-5096 or in Dallas 972-869-0111/ 9am – 4pm Mon-Fri Central time if you have product issues or email us at [service@seidal.com](mailto:service@seidal.com). Please ask for customer service representative for issues involving damages or replacement parts. Please ask for technical assistance representative for any issues with product and assembly/construction.

Please contact the retailer that you purchased from for returns.



**Southern**  
ENTERPRISES

Customer Service 1-800-633-5096  
[service@seidal.com](mailto:service@seidal.com)  
Southern Enterprises, Inc.  
600 Freeport Parkway, Suite 200  
Coppell, Texas 75019