



ELECTRIC TILLER + CULTIVATOR

12-INCH | 8-AMP

OPERATOR'S MANUAL

A Division of Snow Joe®, LLC

Model TJ602E

Form No. SJ-TJ602E-880E-MR4

IMPORTANT! Safety Instructions

All Operators Must Read These Instructions Before Use

Always follow these safety guidelines. Failure to do so may result in serious bodily injury or death.

General Safety WARNINGS!

You and any other operator of this garden tiller + cultivator must read, understand, and follow these instructions in their entirety. Failure to follow these instructions may result in ELECTRIC SHOCK, FIRE, and/or serious PERSONAL INJURY.

Notice the personal safety alert symbol  used in this manual to draw your attention to a WARNING given along with the particular operating instruction. This means that the operation requires special ATTENTION, CAUTION, and AWARENESS.

- 1. Keep work area clean and well-lit** – Cluttered, dark areas invite accidents.
- 2. Replacement parts** – When servicing this unit, use only identical replacement parts. Replace or repair damaged cords immediately.
- 3. Keep children, bystanders, and pets away** – All spectators, including pets, should be kept a safe distance away from the work area.
- 4. Know your product** – Know how to start and stop the machine. Be thoroughly familiar with the controls.
- 5. Use the right tool** – Do not use this machine for any job except that for which it was intended.
- 6. Dress properly** – Do not wear loose clothing or jewelry as such articles can become caught in moving parts. Wear a protective covering to contain long hair. Wearing rubber gloves and substantial non-slip footwear is recommended when working outdoors.
- 7. Extension cords** – To prevent electric shock, use only with an extension cord suitable for outdoor use.
- 8. Avoid accidental starting** – Do not carry the garden tiller + cultivator with your finger on the switch. Make sure the switch is off before plugging in or unplugging the unit.

 **CAUTION!** Moving parts will continue to run for several seconds after turning off the machine.

- 9. Do not abuse the cord** – Never carry the garden tiller + cultivator by the cord or yank the cord to disconnect it from the receptacle. Keep the cord away from heat, oil, and sharp edges.
- 10. Moving parts** – Keep hands and feet away from moving parts. Keep guards in place and in proper working order.
- 11. Do not force the tool** – It will perform better with less likelihood of personal or mechanical injury if it is used at the rate for which it was designed.
- 12. Do not overreach** – Keep proper footing and balance at all times.

If the tiller + cultivator strikes a foreign object, follow these steps:
 - **Stop the electric tiller + cultivator.**
 - **Inspect for damage.**
 - **Repair any damage before restarting and operating the tool.**
- 13. Use safety glasses** – Also use safety footwear, snug-fitting clothing, protective gloves, hearing, and head protection.
- 14. Disconnect the tool** – Disconnect the tiller + cultivator from the power supply when it is not in use, before servicing it, when changing accessories, and when performing any other maintenance task.
- 15. Store idle tool indoors** – When not in use, the tiller + cultivator should be stored indoors in a dry and high or locked-up place out of the reach of children.
- 16. Maintain the tiller + cultivator with care** – Keep the cutting edges sharp and clean for optimal performance and to reduce the risk of injury. Inspect the extension cord periodically and immediately replace it if damaged. Keep the handles dry, clean, and free from oil and grease. Follow the additional recommendations described in the maintenance section of this manual.
- 17. Avoid dangerous environments** – Do not use the tiller + cultivator in rain or in damp or wet locations. Do not operate the tiller + cultivator in gaseous or explosive atmospheres or use the tiller + cultivator near flammable or combustible liquids. Motors in these tools normally spark, and the sparks might ignite fumes.
- 18. Stay alert** – Watch what you are doing. Use common sense. Do not operate the tiller + cultivator when you are tired or under the influence of drugs, alcohol, or other medication.

19. Check for damaged parts – Before further use of the appliance, a guard or other part that is damaged should be carefully checked to determine that it will operate properly and perform its intended function. Check for alignment of moving parts, binding of moving parts, breakage of parts, mounting, and any other condition that may affect its operation. A guard or other part that is damaged should be properly repaired or replaced. Contact the Snow Joe® + Sun Joe® customer service center at 1-866-SNOWJOE (1-866-766-9563) for assistance.

⚠️WARNING! Some dust and debris created by the use of the tool could contain chemicals known to the State of California to cause cancer and birth defects or other reproductive harm. Some examples of these chemicals are:

- Chemicals in fertilizers
- Compounds in insecticides, herbicides and pesticides
- Arsenic and chromium from chemically treated lumber

Your risk from exposure to these chemicals varies, and depends on how often you do this type of work. To reduce your exposure, work in a well-ventilated area and with approved safety equipment, such as dust masks that are specially designed to filter out microscopic particles.

Training

- Read, understand, and follow all instructions on the tiller + cultivator and in the manual before operating this unit. Thoroughly familiarize yourself with the controls and the proper use of the equipment. Know how to stop the unit and disengage the controls quickly.
- Children should never be allowed access to the equipment. Adults should never operate the equipment without carefully reading and understanding these instructions.
- Keep the area of operation clear of all persons, particularly small children or pets.
- Exercise caution to avoid slipping or falling.
- Always plan your cultivating path to avoid discharge of material toward people, pets, and property (e.g. windows, cars, etc.). Thrown objects can cause serious personal injury and property damage. Do not allow anyone in front of a running machine.
- Keep people, pets, and property at least 25 feet from the tiller + cultivator while it is in operation. Stop the tiller + cultivator if people or pets enter the discharge area.
- Always observe the surface conditions in order to avoid slipping, falling, and unexpected objects.

Preparation

- Always inspect the area where the tiller + cultivator is to be used. Remove all objects (i.e. stones, sticks, wires, and other foreign materials) that could be thrown by the blades or cause the operator to trip.
- Thrown objects can cause serious injury to the eyes and

exposed body. Always wear safety glasses or eye shields during operation and while making an adjustment or repair.

- Always operate the tiller + cultivator wearing adequate garments. Do not wear jewelry or other loose clothing, which could become entangled in moving parts. Wear non-slip footwear to ensure proper footing.
- Observe any noise-prevention regulations and laws.
- Inspect the tiller + cultivator for worn, missing, or damaged parts and safety labels. See maintenance section for detailed instructions.

Operation

- Do not operate the machine while under the influence of alcohol or drugs.
- Keep all safety devices in place and in proper working order. Do not operate with missing or damaged components.
- Ensure the controls (start/stop) function properly before cultivating.
- Hold onto the tiller + cultivator with both hands during operation. Ensure the grips are dry.
- Contact with rotating parts can amputate hands and feet. Keep hands and feet away from all rotating parts.
- Only operate the tiller + cultivator when there is good visibility or light and dry conditions. Always watch your footing and keep a firm hold on the grips. Walk; don't run!
- Do not operate the tiller + cultivator on slippery surfaces. Check your footing during use.
- Exercise caution when changing direction and operating the tool on slopes. Always keep feet and legs a safe distance away from the machine. Look for hidden obstacles or hazards.
- Do not overload machine capacity by attempting to cultivate too deeply. It will cause excessive resistance.
- Stop the tiller + cultivator and disconnect the electric cord before leaving the operating position (behind the handles) to adjust or inspect the unit. Wait until the blades have come to a complete stop.
- If the tiller + cultivator should start to vibrate abnormally, stop the machine and inspect thoroughly for damage.
- Turn the machine OFF and disconnect the electrical power when moving to a new work area. Allow the blades to completely stop rotating before transporting the unit.
- Always use proper care and good judgment when you are confronted with a situation that is not covered in this manual. If you are unsure of what to do, contact your authorized Snow Joe® + Sun Joe® dealer or call the Snow Joe® + Sun Joe® customer service center at 1-866-SNOWJOE (1-866-766-9563).
- Do not use in rain or wet conditions.
- Do not grasp the exposed cutting blades or cutting edges when picking up or holding the appliance.

Stopping Work

- Always turn the tiller + cultivator OFF and disconnect the electrical power when stopping work or when changing work areas. Never leave the machine running when unattended.
- The blades will continue to rotate for a short period after turning OFF the tiller + cultivator. Wait until the blades have completely stopped before lifting the machine or conducting inspection and maintenance.
- The motor housing remains hot for a short period after the machine is turned OFF. Allow the motor housing to cool completely before touching or storing near combustible material.

Maintenance + Storage

- Maintain or replace safety and instruction labels.
- Disengage all controls, stop the engine, and wait until the blades come to a complete stop before cleaning, repairing, or inspecting the tiller + cultivator.
- Regularly check the following:
 - Blades are clear and can rotate freely** – Accumulation of debris around the blades could impair performance or damage the motor. Inspect and clean the area around the blades before every use.
 - Safety devices are operating properly** – Do not tamper with or adjust safety devices.
 - Bolts and screws are properly tightened** – Visually inspect the machine for any damage and ensure that the tiller + cultivator is in safe working condition.
 - Use only identical replacement parts** – Always replace damaged parts with original equipment manufacturer’s (OEM) parts only. Replacement parts that do not meet the original equipment specifications may lead to improper performance and compromise safety.

Double-Insulated Appliances

In a double-insulated appliance, two systems of insulation are provided instead of grounding. No grounding means is provided on a double-insulated appliance, nor should a means for grounding be added to the appliance. Servicing a double-insulated appliance requires extreme care and knowledge of the system, and should be performed only by qualified service personnel at an authorized Snow Joe® + Sun Joe® dealer. Replacement parts for a double-insulated appliance must be identical to the parts they replace. A double-insulated appliance is marked with the words “Double Insulation” or “Double Insulated.” The symbol  (square within a square) may also be marked on the appliance.





DOUBLE-INSULATED: GROUNDING NOT REQUIRED. WHEN SERVICING, USE ONLY IDENTICAL REPLACEMENT PARTS.

This electric tiller + cultivator is double-insulated, eliminating the need for a separate grounding system. Use only identical replacement parts. Read the instructions before servicing double-insulated appliances. Use this electric tiller + cultivator only as described in this manual.

Electrical Safety

1. Ground fault circuit interrupter (GFCI) protection should be provided on the circuit(s) or outlet(s) to be used for this electric tiller + cultivator. Receptacles are available having built-in GFCI protection and may be used for this measure of safety.
2. To prevent electric shock, use only with an extension cord suitable for outdoor use, such as SW-A, SOW-A, STW-A, STOW-A, SJW-A, SJOW-A, SJTW-A, or SJTOW-A.

Before use, check that the extension cord is in good condition. When using an extension cord, make sure to use one heavy enough to carry the current to the product. An undersized cord will cause a drop in line voltage resulting in loss of power and overheating.

WARNING

Electric shock may cause SEVERE INJURY or DEATH. Heed these warnings:

- Do not allow any part of the electric tiller + cultivator to make contact with water while it is in operation. If the appliance becomes wet while turned off, wipe dry before starting.
- Use only a UL-, CSA-, or ETL-rated extension cord for outdoor, all-weather use.
- Do not use an extension cord over 100 ft (30 m).
- Do not touch the appliance or its plug with wet hands or while standing in water. Wearing rubber boots offers some protection.

EXTENSION CORD CHART

Extension Cord Length	Up to 50 ft (15 m)	+50 ft - 100 ft (+15 m - 30 m)
Wire Gauge (A.W.G.):	16	14

- To reduce the risk of electric shock, this appliance has a polarized plug (i.e. one blade is wider than the other). Use this appliance only with a polarized UL-, CSA-, or ETL-listed extension cord recommended for outdoor, all-weather use, such as the Snow Joe® + Sun Joe® Power Joe SJTW-A 14-gauge 50-foot extension cord with lighted end (Model PJEXT50-B). Visit sunjoe.com to purchase this extension cord online or, to order by phone, call 1-866-SNOWJOE (1-866-766-9563).

The appliance plug will fit into a polarized extension cord only one way. If the appliance plug does not fit fully into the extension cord, reverse the plug. If the plug still does not fit, obtain a correct polarized extension cord. A polarized extension cord will require the use of a polarized wall outlet. The extension cord plug will fit into the polarized wall outlet only one way. If the plug does not fit fully into the wall outlet, reverse the plug. If the plug still does not fit, contact a qualified electrician to install the proper wall outlet. Do not modify the appliance plug, extension cord receptacle, or extension cord plug in any way.

- To prevent the appliance cord from disconnecting from the extension cord during operation, use the onboard extension cord restraint hook and/or make a knot with the two cords as shown in Table 1.

Table 1. Method of Securing Extension Cord

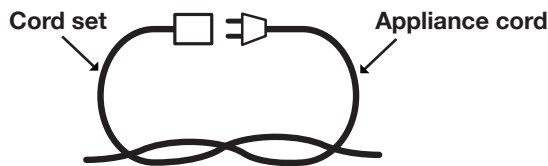

(A) Tie cord as shown

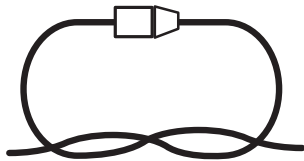













(B) Connect plug and receptacle

- Do not abuse the cord. Never pull the tiller + cultivator by the cord or yank the cord to disconnect it from the receptacle. Keep the cord away from heat, oil, and sharp edges.

Safety Symbols

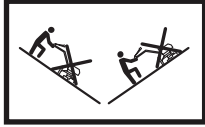
The following table depicts and describes safety symbols that may appear on this product. Read, understand, and follow all instructions on the machine before attempting to assemble and operate.

Symbols	Descriptions	Symbols	Descriptions
	READ THE OPERATOR'S MANUAL(S) – Read, understand, and follow all instructions in the user manual(s) before attempting to assemble and operate.		Wear eye protection, breathing protection, and ear protection (i.e. safety goggles, dust masks, and ear defenders).
	SAFETY ALERT – Indicates a precaution, a warning, or a danger.		WARNING! Do not expose the unit to rain or wet conditions.
	WARNING! Keep electrical extension cord away from blades.		WARNING! Rotating parts may cause serious injury. Make sure the blades come to a complete stop before transporting the machine or before inspecting, cleaning, or conducting any other maintenance.
	SWITCH OFF! Remove plug from the outlet before cleaning or conducting maintenance checks.		SWITCH OFF! Remove plug from the outlet immediately if the cord is damaged or cut.
	Beware of foreign objects that could be thrown from the appliance. Keep bystanders a safe distance away from the work area.		Inspect the work area prior to use and remove all objects that could be thrown by the appliance. If a hidden object is discovered while working, stop the engine and remove the object.
	Wear protective gloves and non-slip footwear when using the machine and handling debris.		Work across slopes; never work up and down such surfaces.
	The rotating part will continuously run for several seconds after you turn off the machine.		DOUBLE INSULATION – When servicing, use only identical replacement parts.

Know Your Electric Tiller + Cultivator

Read the owner's manual and safety instructions carefully before operating the electric tiller + cultivator. Compare the illustration below to the electric tiller + cultivator in order to familiarize yourself with the location of the various controls and adjustments. Save this manual for future reference.

1. ON/OFF trigger
2. Extension cord restraint holder
3. Safety lock button
4. Upper handle
5. Appliance cord
6. Upper handle knob, spacer and bolt (2)
7. Cable clip
8. Middle handle
9. Lower handle knob, spacer and bolt (2)
10. Transport handle
11. Air vents
12. Motor housing
13. Guard
14. Lower handle
15. Wheels
16. Steel blade (4)
17. Gear box

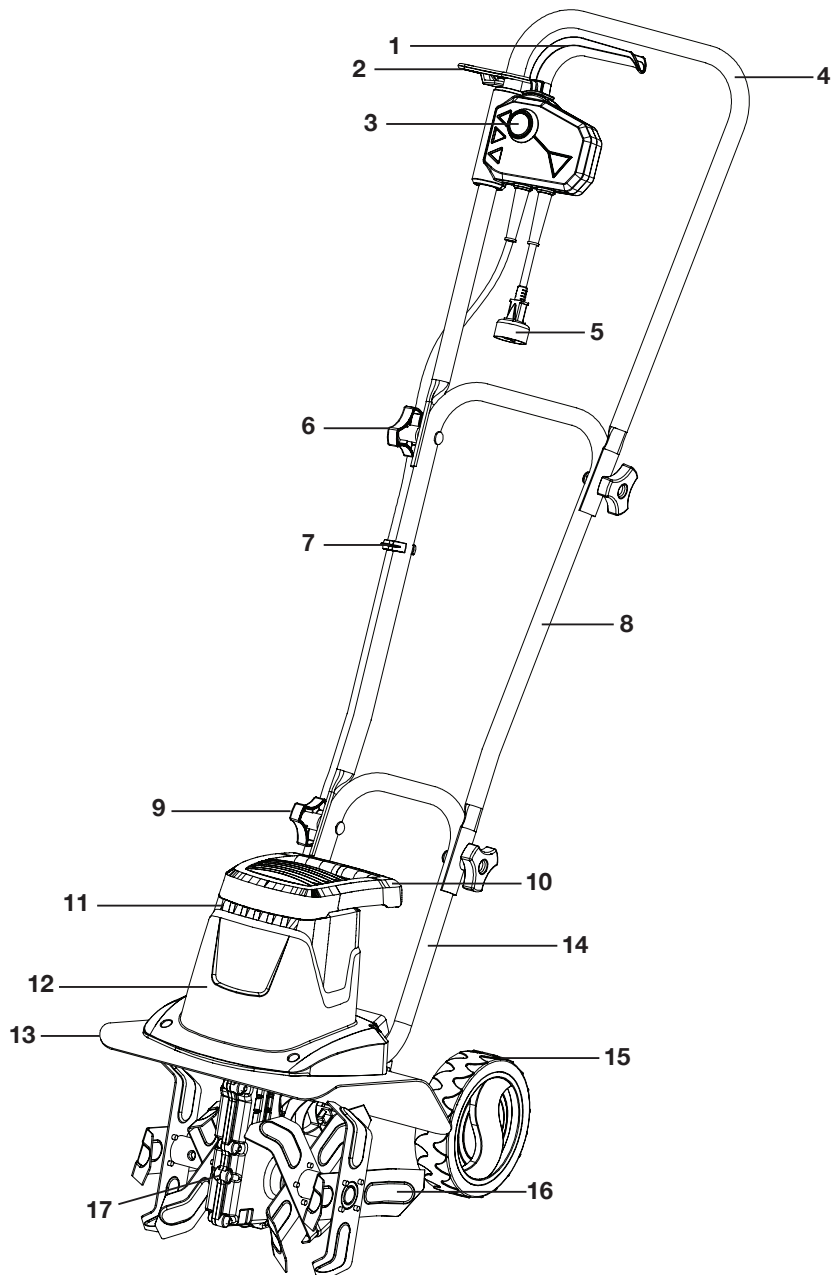

Technical Data

Rated Voltage..... 120 V ~ 60 Hz
 Motor..... 8 A
 No Load Speed.....300 ± 10% rpm
 Handle.....Foldable (3 sections)

Rotor..... 4 steel tilling blades
 Cultivating Width Max..... 12 in. (30.5 cm)
 Cultivating Depth Max..... 8 in. (20.3 cm)
 Weight..... 23.15 lbs (10.5 kg)

Unpacking

Carton Contents

- Electric tiller + cultivator housing
- Upper handle
- Middle handle
- Extension cord restraint holder
- Cable clip
- Handle knob, spacer and bolt (4)
- Manual with registration card

1. Carefully remove the electric tiller + cultivator and check to see that all of the above items are supplied.
2. Inspect the product carefully to make sure no breakage or damage occurred during shipping. If you find damaged or missing parts, DO NOT return the unit to the store. Please call the Snow Joe® + Sun Joe® customer service center at 1-866-SNOWJOE (1-866-766-9563).

NOTE: Do not discard the shipping carton and packaging material until you are ready to use the electric tiller + cultivator. The packaging is made of recyclable materials. Properly dispose of these materials in accordance with local regulations or save the packaging for long-term product storage.

IMPORTANT! The equipment and packaging material are not toys. Do not let children play with plastic bags, foils, or small parts. These items can be swallowed and pose a suffocation risk!

Assembly

⚠ WARNING! Do not connect to the power supply until assembly is complete. Failure to comply could result in accidental starting and serious personal injury.

⚠ WARNING! To prevent serious personal injury, make sure the unit is unplugged, and the blades have come to a complete stop before inspecting, cleaning, or servicing the unit.

⚠ WARNING! The product must be fully assembled before operation. Do not use a product that is only partially assembled or assembled with damaged parts.

Follow the assembly instructions step-by-step and use the pictures provided as a visual guide to easily assemble the product.

Connecting the Handles

NOTE: Small parts can easily get lost during assembly or when making adjustments to the machine. To avoid this, secure all small parts that are removed from the machine and keep them accessible.

1. Attach the cable clip on the middle handle bar (Fig. 1).

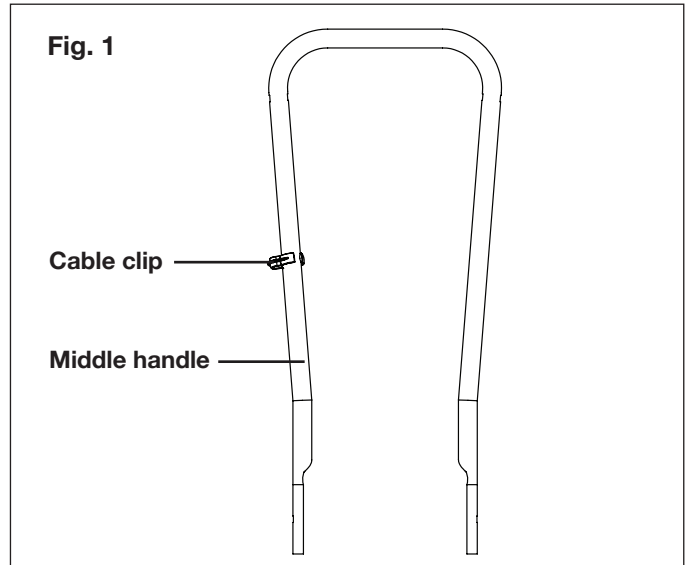

2. Remove the bolts from the knobs and keep them handy.
3. Secure the middle handle to the lower handle using the first set of knobs, spacers and bolts (A). Tighten the knobs on each side to ensure a secure fit (Fig. 2).

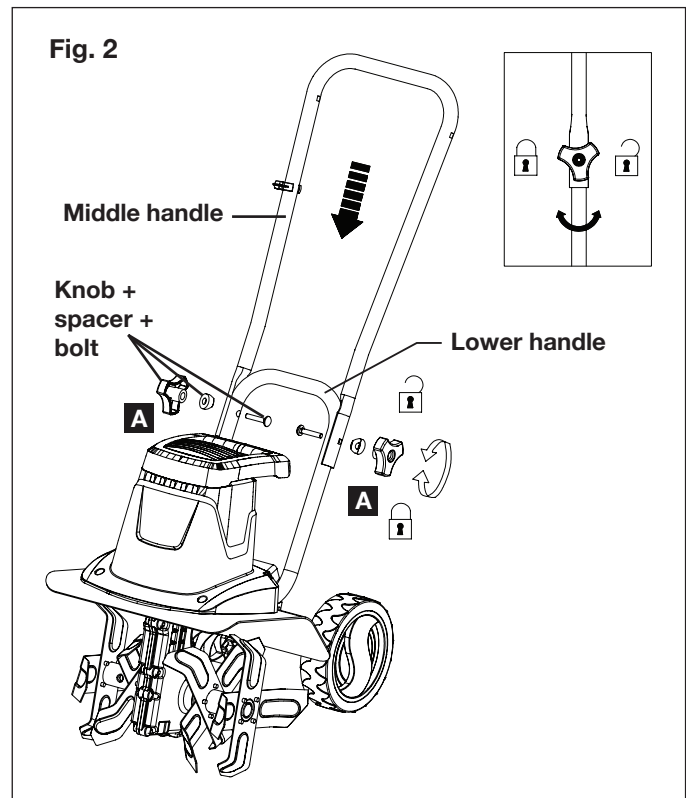

4. Slide the extension cord restraint holder onto the upper handle (Fig. 3).

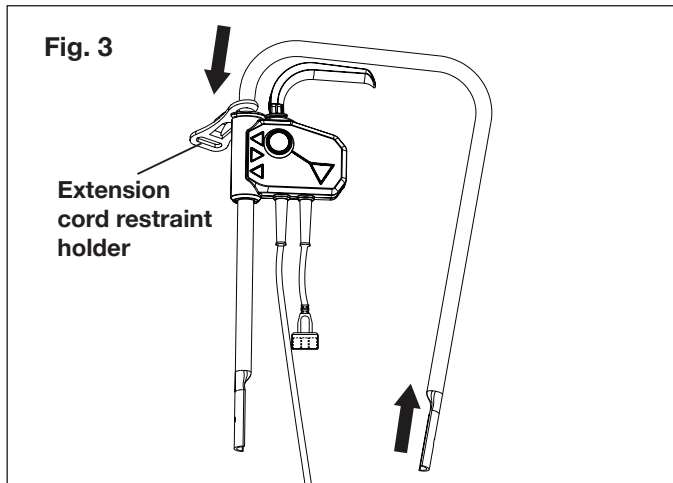

5. Connect the upper handle to the middle handle using the second set of knobs, spacers and bolts (B). Tighten the knobs on each side to ensure a secure fit (Fig. 4).

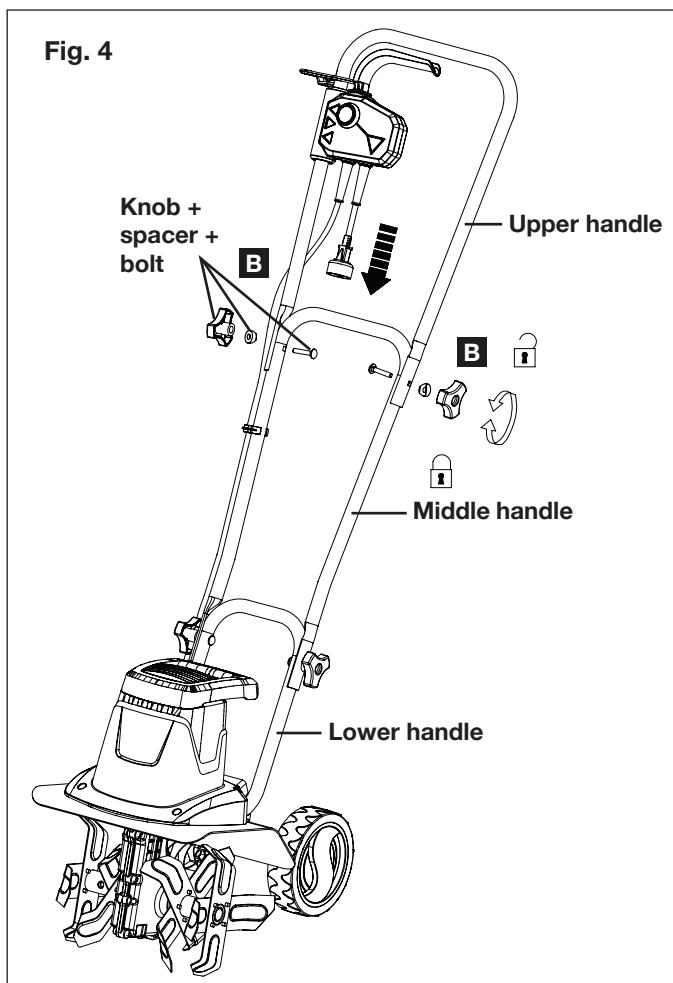

6. Secure the cable inside the cable clip (Fig. 5).

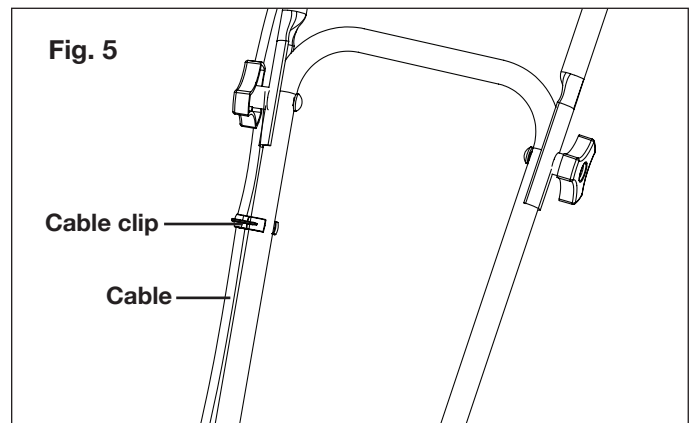

⚠ WARNING! Make sure all handle knobs are properly tightened before using the electric tiller + cultivator.

Operation

Intended Use

The TJ602E electric tiller + cultivator is designated with a rated input power consumption of 960 Watts.

Designed for small gardens and flower beds, this electric tiller + cultivator effectively loosens and turns over new soil. It may also be used to mix coarse soil with fertilizer, peat, and compost. This product may not be used to till extremely dry or wet soil.

The use of this product in rain or wet conditions is prohibited.

For safety reasons, it is essential to read the entire instruction manual before first use and to observe all the instructions contained within this manual.

This product is intended for private domestic use only. It is not intended for any commercial trade use. It must not be used for any purposes other than those described.

Connecting to Power Supply

NOTE: For safety reasons, this product is equipped with a short power cord. Do not connect the electric tiller + cultivator directly to the power supply using this power cord. A proper extension cord is required for operation. Observe the technical requirements for this product when purchasing an extension cord.

⚠ WARNING! For your safety, it is required that the plug attached to this electric tiller + cultivator be connected to an approved extension cord. The extension cord must be suitable for outdoor use, with all sockets protected against water intrusion. Ensure the extension cord is of the proper size and type for your product ($\geq 1.5 \text{ mm}^2$). Always use a residual-current device (RCD), or residual-current circuit breaker (RCCB) protected power supply.

1. Connect the electric tiller + cultivator to a working 120 V outlet using a heavy-duty outdoor extension power cord, such as the Snow Joe® + Sun Joe® Power Joe SJTW-A 14-gauge 50-foot extension cord with lighted end (Model PJEXT50-B). Visit sunjoe.com to order online or call 1-866-SNOWJOE (1-866-766-9563) to order by phone.
2. Push a loop of the extension cord through the slot on the extension cord restraint holder from the opposite side of the restraint holder (Fig. 6). Insert the appliance cord into a proper outdoor extension cord (see Extension Cord Chart on page 4).

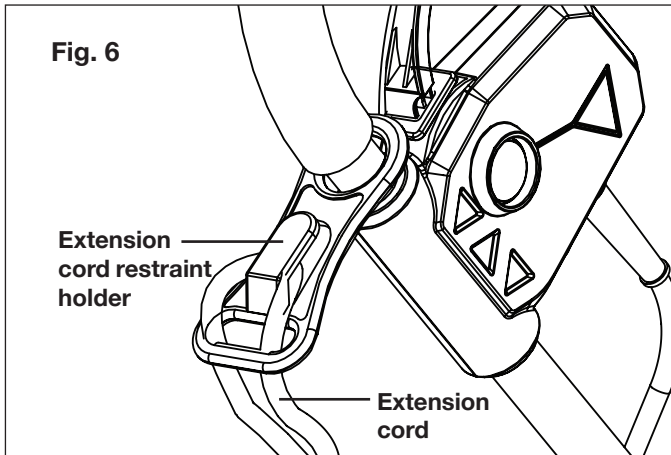

⚠️ WARNING! Check the voltage to ensure it complies with the information on the rating label.

Wheel Adjustment

⚠️ WARNING! Always switch the product off and disconnect it from the power supply before making any adjustments.

The wheels can be adjusted to 3 different positions to control the cultivating depth.

1. Pull the wheel and move it to the desired position; let go of the wheel and make sure it locks into position (Fig. 7). Be sure to set both wheels to the same height.

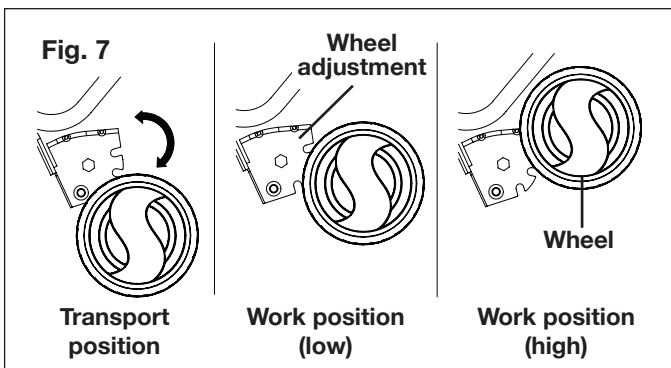

⚠️ WARNING! Always ensure the wheels are securely locked. Do not attempt to use the product with the wheels in unlocked positions.

Powering ON + OFF

⚠️ WARNING! Rotating blades may cause serious injury. The blades will continue to turn for a few seconds after the tool has been switched OFF. Do not touch the rotating blades. Contact with hot components (i.e. motor housing, gear box, etc.) on the machine may cause burns. Allow the machine to cool before handling.

1. To turn the tool ON, press and hold the safety lock button while pulling the ON/OFF trigger toward you. Once the tool is running, release the safety lock button (Fig. 8).

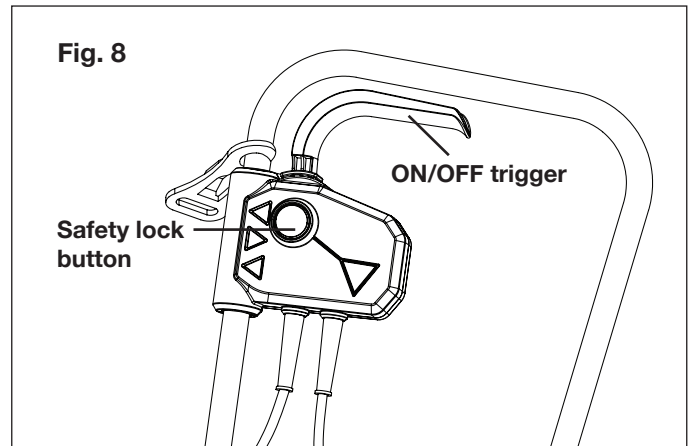

2. To switch OFF, release the ON/OFF trigger (Fig. 8).

Operating Tips

- Before each use, check the product, its power cord and plug, and any other accessories for damage. Do not use the product if it is damaged or shows wear.
- Double check that the accessories and attachments are properly fitted.
- Always hold the product by its handles. Keep the handles dry to ensure a secure grip.
- Ensure that the air vents are always unobstructed and clear. Clean them if necessary with a soft brush. Blocked air vents may lead to overheating and damage the product.
- Switch the product off immediately if you are disturbed while working by other people entering the working area. Always let the product come to a complete stop before averting your attention.
- Do not overwork yourself. Take regular breaks to ensure you can concentrate on the task at hand and have full control over the product.

⚠️ WARNING! In some countries, regulations define restrictions for use of such products, including the times and days when operation is permissible. Ask your community for detailed information and observe these regulations in order to preserve a peaceful neighborhood and avoid committing administrative offences.

Tilling

- Make sure that the work area is clear of stones, sticks, wire, or other objects that could damage the product or its motor.
- Do not till very wet soil because wet soil tends to stick to the working tool, preventing proper blade rotation; it could also cause you to slip and fall.
- Always maintain a firm grip on the product. For better guidance, apply light pressure to the handles.

⚠️ WARNING! Do not place hands, feet, or any other part of the body or clothing near the rotating blades or any other moving part. The blades begin to rotate forward once the trigger switch is depressed. The blades continue to rotate until the trigger switch is released. Failure to avoid contact with the rotating blades could cause serious personal injury.

- Do not try to till too deeply or force the product into soil that is extremely hard or resistant.
- Walk the product through the soil at a normal pace and in as straight a line as possible.
- Till in slightly overlapping rows. To till most effectively, follow the pattern indicated in Fig. 9. Start by moving the tiller + cultivator up and down in vertical lines, then work horizontally from left to right. This will keep the rows even and ensure that all the ground is tilled without missing any spots.

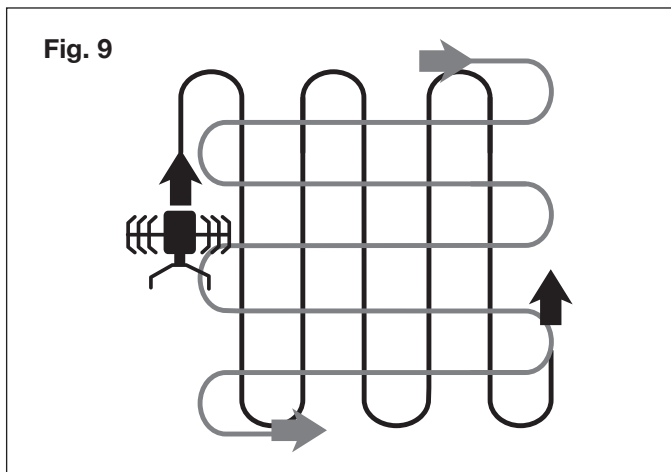

- Pay special attention when changing direction. Apply light pressure to the handle in order to lift the blades and facilitate the turn. Turn the product around using the wheels as a guide. Gradually release pressure on the handle and move the blades back to the ground.

⚠️ WARNING! Stop the motor if the product strikes a foreign object. Switch the product off, disconnect it from the power supply, and let it cool completely. Inspect the product thoroughly for damage and have any damage repaired before restarting.

Extensive vibration of the product during operation is an indication of damage. Immediately stop the motor and promptly inspect and repair the tool.

After Use

- Switch the product off, disconnect it from the power supply, and let it cool completely.
- Check, clean, and store the product as described below.

Care + Maintenance

The Golden Rules for Care

⚠️ WARNING! Always switch the product off, disconnect the product from the power supply, and let the product cool completely before inspecting, cleaning, or performing any other maintenance task.

- Keep the product clean. Remove any debris after each use and before storage.
- Regular and proper cleaning will help ensure safe use and prolong the life of the product.
- Inspect the product before each use for worn and damaged parts. If you find broken and/or worn parts, do not use the tool.

⚠️ WARNING! Only perform the repairs and maintenance work described in this manual. Any other work must be performed by a qualified technician.

General Cleaning

- Clean the product with a dry cloth. Use a brush for areas that are hard to reach.
- Be sure to clean the air vents after every use with a cloth and brush.
- Remove stubborn dirt with high pressure air (max. 3 bar).

NOTE: Do not use chemical, alkaline, abrasive, or other aggressive detergents or disinfectants to clean this product as such substances might damage the tool's surfaces.

- Check for worn or damaged parts. Replace worn parts as necessary or contact the Snow Joe® + Sun Joe® customer service center at 1-866-SNOWJOE (1-866-766-9563) for repair before using the product again.

Cleaning the Underbody + Working Tool

⚠️ WARNING! Wear safety gloves when working on or near the working tool. Use appropriate tools (e.g a wooden stick) when necessary; never use your bare hands!

- Keep the underbody and blades clean and free of debris. Use a brush or another implement to remove soil from the working tool.

- All nuts and bolts must be checked periodically for tightness before operation. After prolonged use, especially in sandy soil conditions, the working tool will become worn and lose some of its original shape. Tilling efficiency will be reduced and the working tool should be replaced.
- Have worn or damaged working parts replaced with new ones of the same type by a qualified technician.
- To prolong the life span of the working tool and the product, lubricate the blades after each use.

Maintenance

⚠️ WARNING! Unexpected blade movement may cause personal injury. Before servicing, repairing, or inspecting the unit, turn the motor OFF and disconnect the extension cord. Wait for the blades to completely stop rotating before conducting inspection, cleaning, or maintenance.

Before and after each use, check the product and accessories (or attachments) for wear and damage. When necessary, only use identical replacement parts that are approved by the manufacturer.

⚠️ WARNING! Contact with hot components (e.g. motor housing, gear box, etc.) on the machine may cause burns. Allow the machine to cool off before handling.

IMPORTANT!

- Wear protective gloves when cleaning or maintaining the machine.
- Do not use cleaning fluids or solvents or spray the machine down with water (especially water under pressure) when cleaning the machine.

NOTE: After each use, follow these steps to properly clean the unit:

1. Remove soil, dirt, and foliage stuck in the blades, drive shaft, tool surface, and vents with a brush or dry cloth.
2. Spray or rub biodegradable oil onto the blades.
3. Clean soiled grips with a damp cloth.

Always inspect the machine for damaged and worn parts after each use. Check that safety features (i.e. labels, guards, etc.) are in place. Check that nuts, bolts, and screws are tight.

Changing the Blades

NOTE: The machine is fitted with four tilling blades that can easily be changed in pairs. Both of the steel blade pairs can be fitted on the left or right, as required. Always change both blade pairs at the same time to avoid imbalance and damage to the machine.

To replace the blades, follow the steps below:

1. While standing on a flat and stable surface, switch off the unit and remove the plug from the extension cord.

2. Remove the 2 bolts and 2 nuts, then remove the steel blades (Fig. 10).

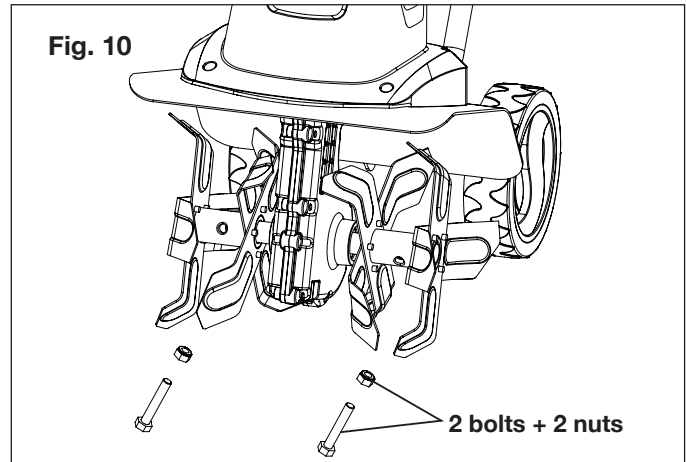

3. Clean the drive shaft with biodegradable oil (Fig. 11).
4. Place the new blades onto the drive shaft so that the holes on the axles line up with the holes on the drive shaft (Fig. 11).
5. Insert the 2 bolts through the holes and secure them with the 2 nuts (Fig. 11).

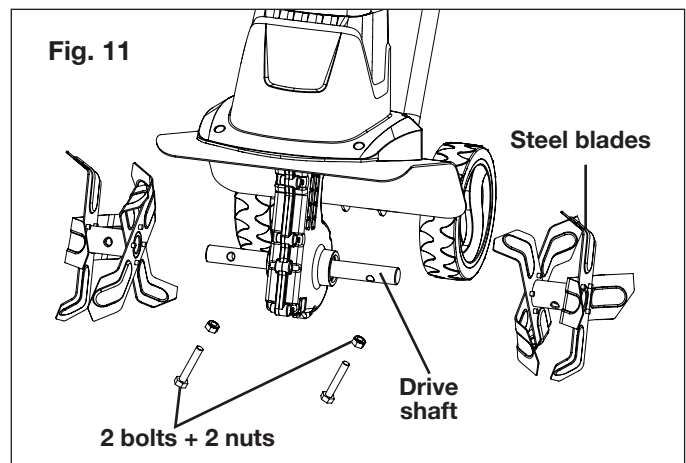

IMPORTANT: The blades must be set in the correct turning direction. Note the way the old blades came off and replace the new ones exactly the same way.

Power Cord

If the power cord is damaged, it must be replaced in order to avoid a safety hazard. Contact your authorized Snow Joe® + Sun Joe® dealer or call the Snow Joe® + Sun Joe® customer service center at 1-866- SNOWJOE (1-866-766-9563).

Repair

This product does not contain any parts that can be repaired by the consumer. Contact an authorized Snow Joe® + Sun Joe® dealer or call the Snow Joe® + Sun Joe® customer service center at 1-866-SNOWJOE (1-866-766-9563) for assistance.

Storage

- Examine the electric tiller + cultivator thoroughly for worn, loose, or damaged parts. Should you need to repair or replace a part, contact an authorized Snow Joe® + Sun Joe® dealer or call the Snow Joe® + Sun Joe® customer service center at 1-866-SNOWJOE (1-866-766-9563) for assistance.
- Examine the extension cord thoroughly for signs of excess wear or damage. If it is worn or damaged, replace it immediately.
- Disconnect the extension cord from the electric tiller + cultivator before storing.
- Clean the product as described above.
- Store the product and its accessories in a dark, dry, frost-free, and well-ventilated place.
- Always store the product in a place that is inaccessible to children.
- The ideal storage temperature is between 50°F (10°C) and 86°F (30°C).
- We recommend using the original package for storage or covering the product with a suitable cloth or enclosure to protect it against dust.

Transportation

- Switch the product off and disconnect it from the power supply. Ensure that the wheels are set to the transport position (see Fig. 7, pg. 9).
- Always carry the product by its transport handle.
- If you are transporting the tiller + cultivator in a vehicle, brace it properly to protect it from heavy impact or strong vibrations.
- Secure the product to prevent it from falling over or slipping.

Recycling + Disposal

The product comes in a package that protects it against damage during shipping. Keep the package until you are sure that all parts have been delivered and the product is functioning properly. Recycle the package afterwards or keep it for long-term storage.



WEEE symbol. Waste electrical products should not be disposed of with household waste. Please recycle where facilities exist. Check with your local authority or local store for recycling regulations.

Service + Support

If your Sun Joe® TJ602E electric tiller + cultivator requires service or maintenance, please call the Snow Joe® + Sun Joe® customer service center at 1-866-SNOWJOE (1-866-766-9563).

Model + Serial Numbers

When contacting the company, reordering parts, or arranging service from an authorized dealer, you will need to provide the model and serial numbers, which can be found on the decal located on the housing of the unit. Copy these numbers into the space provided below.

Record the following numbers from the housing or handle of your new product:	
Model #:	
T J 6 0 2 E	
Serial #:	

Optional Accessories

⚠ WARNING! ALWAYS use only authorized Snow Joe® + Sun Joe® replacement parts and accessories. NEVER use replacement parts or accessories that are not intended for use with this electric tiller + cultivator. Contact Snow Joe® + Sun Joe® if you are unsure whether it is safe to use a particular replacement part or accessory with your electric tiller + cultivator. The use of any other attachment or accessory can be dangerous and could cause injury or mechanical damage.

NOTE: Accessories are subject to change without any obligation on the part of Snow Joe® + Sun Joe® to provide notice of such changes. Accessories can be ordered online at sunjoe.com or via phone by contacting the Snow Joe® + Sun Joe® customer service center at 1-866-SNOWJOE (1-866-766-9563).



SNOW JOE® + SUN JOE® CUSTOMER PROMISE

ABOVE ALL ELSE, Snow Joe® + Sun Joe® are dedicated to you, our customer. We strive to make your experience as pleasant as possible. Unfortunately, there are times when a product does not work or breaks under normal operating conditions. We think it's important that you know what you can expect from us. That's why we created the Snow Joe® + Sun Joe® promise.

OUR PROMISE: Snow Joe® + Sun Joe® warrant new products for two years from the date of purchase. If your product does not work, or there's an issue with a specific part, we will fix this by either sending you a free replacement part or by sending you a new or comparable product at no charge. How cool is that! Before you know it, you'll be back in action cutting, sawing, mowing, washing and...?

PRODUCT REGISTRATION:

Snow Joe®, LLC ("Snow Joe® + Sun Joe®") strongly encourages you to register your purchase. You can register online at snowjoe.com/ProductRegistration, or by printing and mailing in a registration card available online from our website, or calling our Customer Service Department at **1-866-SNOWJOE (1-866-766-9563)**, or by e-mailing us at help@snowjoe.com. Failure to register your product purchase will not diminish your warranty rights. However, registering your purchase will allow Snow Joe® + Sun Joe® to better serve you with any of your customer service needs.

WHO CAN SEEK WARRANTY COVERAGE?

This Warranty is extended by Snow Joe® + Sun Joe® to the owner of this Machine (a "Machine" consists of a product powered by a motor) for residential and personal household use only. This Warranty does not apply to products used for commercial, rental or re-sale purposes. Should ownership of this machine change during the 2-year period, please update the Machine's owner information at snowjoe.com/ProductRegistration.

WHAT IS COVERED?

Snow Joe® + Sun Joe® warrants to the owner that if this Machine fails within 2 years from the date of purchase due to a defect in material or workmanship or as a result of normal wear and tear from ordinary household use, Snow Joe® + Sun Joe® will send a replacement part or product, as needed, free of charge and with free shipping to the original purchaser.

If, in Snow Joe® + Sun Joe®'s sole discretion, the failed Machine cannot be repaired with a part, Snow Joe® + Sun Joe® will elect to either (A) send a new Machine at no charge and with free shipping or (B) refund the full purchase price to the owner.

WHAT IS NOT COVERED?

This Warranty does not apply to the Machines that have been used commercially or in non-household applications. This Warranty does not cover cosmetic changes that do not affect performance. This Warranty is only valid if the Machine is used and maintained in accordance with the instructions, warnings and safeguards contained in the owner's manual. Snow Joe® + Sun Joe® will not be responsible for the cost of any unauthorized warranty repairs. This warranty does not cover any cost or expense incurred by the purchaser in providing substitute equipment or service during reasonable periods of malfunction or non-use of this product while waiting for a replacement part or unit under this warranty.

Wearing parts like belts, augers, chains and blades are not covered under this warranty, and can be purchased at snowjoe.com or by calling **1-866-SNOWJOE (1-866-766-9563)**. Batteries are covered in full for 90-days from the date of purchase.

Repair, replacement or refund of the purchase price are the exclusive remedies of purchaser and the sole liability of Snow Joe® + Sun Joe® under this warranty. No employee or representative of Snow Joe® + Sun Joe® is authorized to make any additional warranty or any modification to this warranty which may be binding upon Snow Joe® + Sun Joe®. Accordingly, purchaser should not rely upon any additional statements made by any employee or representative of Snow Joe® + Sun Joe®. In no event, whether based on contract, indemnity, warranty, tort (including negligence), strict liability or otherwise, shall Snow Joe® + Sun Joe® be liable for any special, indirect, incidental, or consequential damages, including, without limitation, loss of profit or revenue.

Some states do not allow limits on warranties. In such states, the above limitations may not apply to you.

Outside the USA, other warranties may apply.



sunjoe.com