



Maximum weight capacity  
of **750 lbs** evenly distributed

## Work Tables

Large - 72"W x 23"D x 32" to 44.5"H (adjustable height)

Small - 44"W x 23"D x 32" to 44.5"H (adjustable height)

## Use & Care Guide

**Read all instructions and warnings before proceeding.**

If you do not understand any portion of the instructions, do not attempt assembly;

EMAIL : [customerservice@kindredproducts.net](mailto:customerservice@kindredproducts.net)

Call : (866) 456-0866.

This Use & Care Guide provides instructions on how to assemble and use your Everest™ Work Table.

It is critical that the Work Table be assembled correctly and according to the instructions.

The product is intended for use in working areas including offices, homes, craft rooms, garages, etc.

**WARNING!**

1. Strictly follow all instructions to avoid an accident, damage to property, personal injury, or death.
2. Do not sit, stand, or climb on work table and do not let children do so. Components might fail, causing a person to fall, possibly resulting in serious injury or death.
3. FOR CALIFORNIA RESIDENTS ONLY - WARNING: Cancer and reproductive harm. For full information, go to [www.P65Warnings.ca.gov](http://www.P65Warnings.ca.gov).

It is the consumer's responsibility to:

- Assemble this system in accordance with provided instructions
- Maximum weight capacity of 750 lbs evenly distributed
- Failure to follow warning could result in serious injury

# Preparation

1. Find a soft surface for the assembly process to avoid any scratching (e.g. on top of a rug, a carpet, or the broken down shipping box).

2. One-person assembly is suggested or feel free to invite a friend or family member to help assemble.

## You may need

· Phillips Screwdriver

# Box Includes



## UNPACKING AND ASSEMBLING YOUR PRODUCT SAFELY

When you receive your product, please proceed with caution during the unpacking process. To avoid any potential injury or damage to the product, gently remove the packing materials and carefully allow for the wood top to be set aside to avoid any damage or scratching of the surface. Ensure that you have ample space to work with, avoiding any cramped or cluttered area that may hinder the assembly process. If necessary, seek assistance to stabilize the work table and components during the assembly process and when flipping the work table to the upright position.

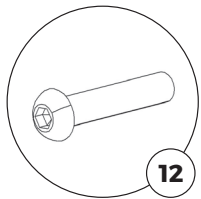

**(A)** Corner Bolt

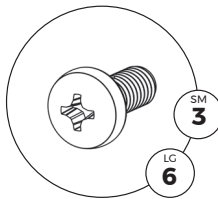

**(B)** Small Bolt

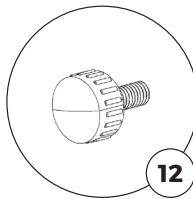

**(C)** Thumb Screw

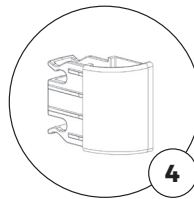

**(D)** Corner Caps

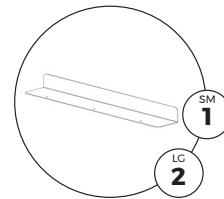

**(E)** Cord Management Tray

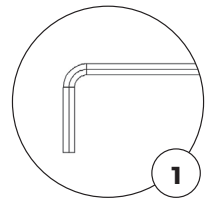

**(H)** Allen Wrench

NOTE: Leveling Feet and the Leveling Feet Caps are pre-installed for your convenience.

NOTE: The Table image depicts the Large Work Table, but it is important to note that the components are identical for the Small Work Table as well. This means that the assembly instructions and parts list apply equally to both table sizes, ensuring a seamless setup process regardless of your choice.

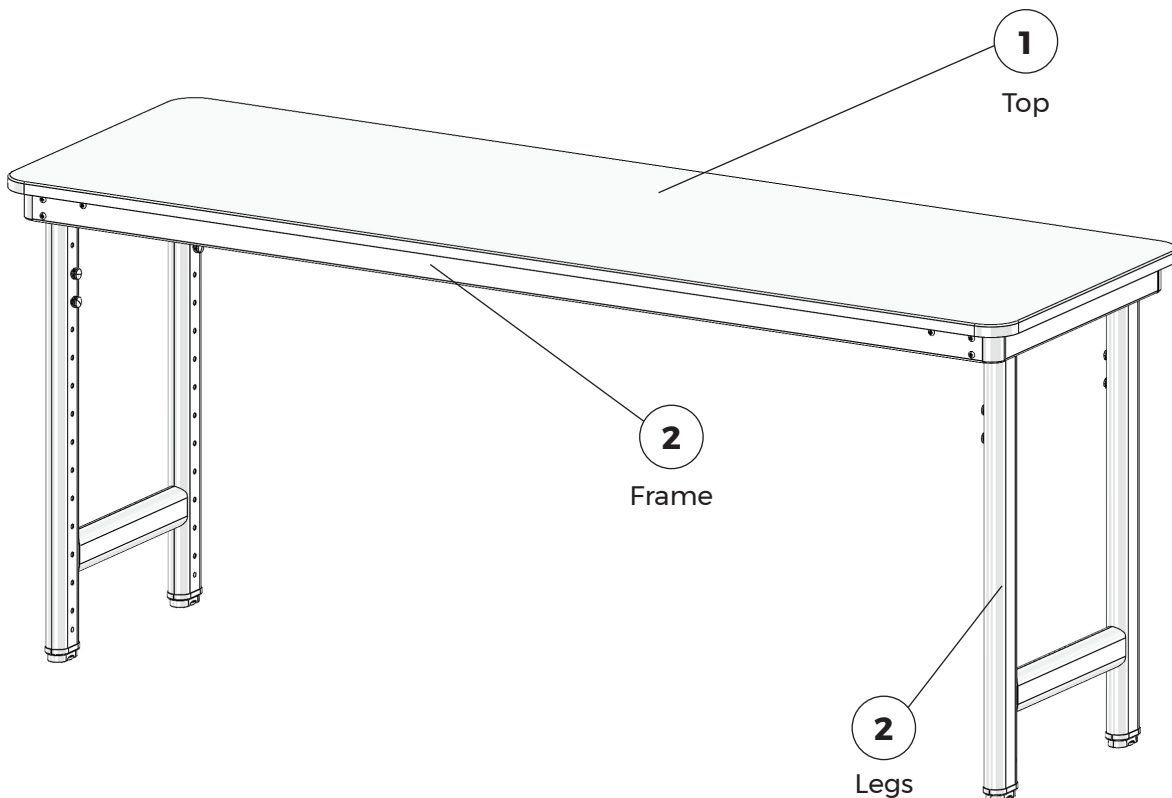

## STEP 1

Place the Wood Top (Small or Large) upside down on a clean surface (or leave in the box where it is protected).

Take 1 leg assembly (with feet upright) and attach 1 thumb screw into the nut on the underside of the Wood Top (See magnified view).

**NOTE:** Do not tighten the thumb screw until after STEP 2. This will allow easier alignment when attaching the front and back Frames of the Work Table.

Repeat with 2nd leg assembly.

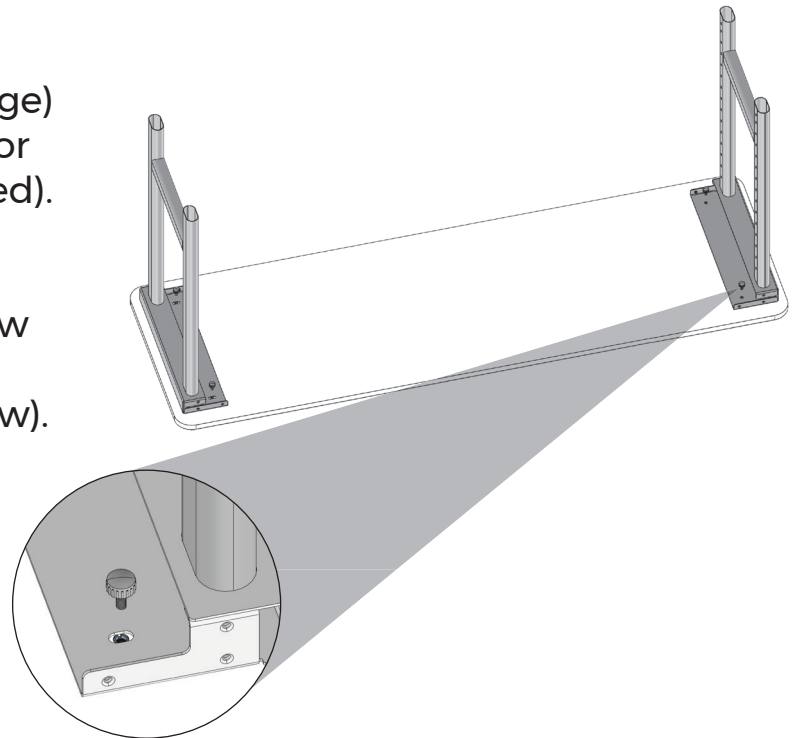

## STEP 2

With the Work Table still upside down, place the Frame against the leg assembly so that the bolt holes are aligned. As the thumbs screws are still loose, slide the Frame as needed to align the bolt holes.

Insert and tighten the 3 Corner Bolts (**A**) to the corner of the Frame and repeat this step at the opposite end (See magnified view).

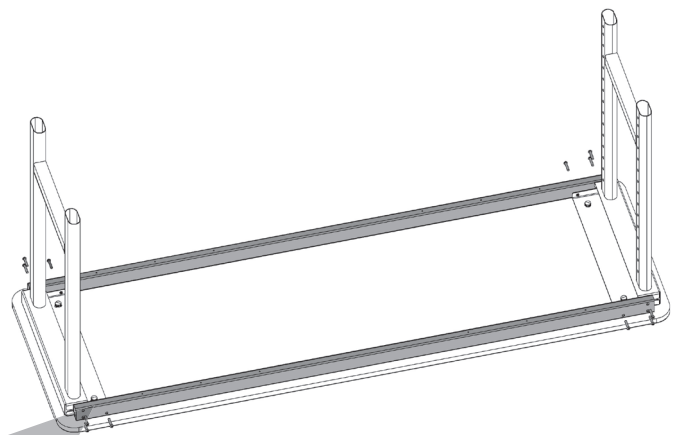
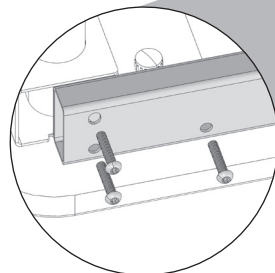

Repeat these steps for the opposite side of Frame.

As noted in STEP 1, tighten each of the 4 thumb screws into the nuts on the underside of the Wood Top (1 per corner as part of the leg assembly).

## STEP 3

With the Work Table still in the upside down position, attach Corner Caps (4) to each corner of the Work Table.

Align the Corner Cap **(D)** with the Work Table Frame and the Corner Bolts **(A)**. Push inwards until the Corner Cap snaps into place. The Corner Cap will be flush to both sides of the Work Table Frame and Leg Assembly parts (See magnified view).

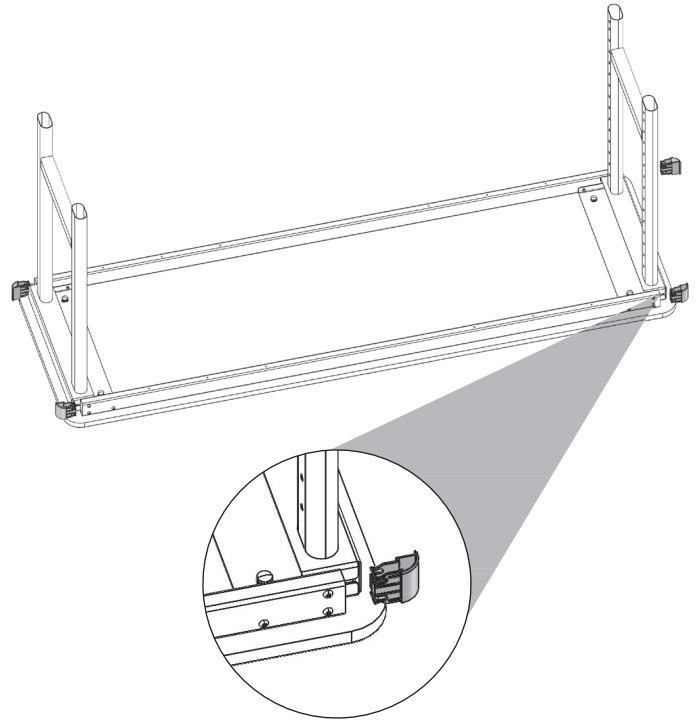

## STEP 4

2 Cord Management Trays have been provided for the 72" Work Table.

1 Cord Management Tray has been provided for the 44" Work Table.

The Cord Management Tray(s) may be installed on either side of the Work Table. The tray(s) may also be installed to fit under the Work Table for a more seamless look or extend out from the Work Table. To install, use the Small Bolts **(B)** to secure the tray (in either direction) to the Work Table Frame.

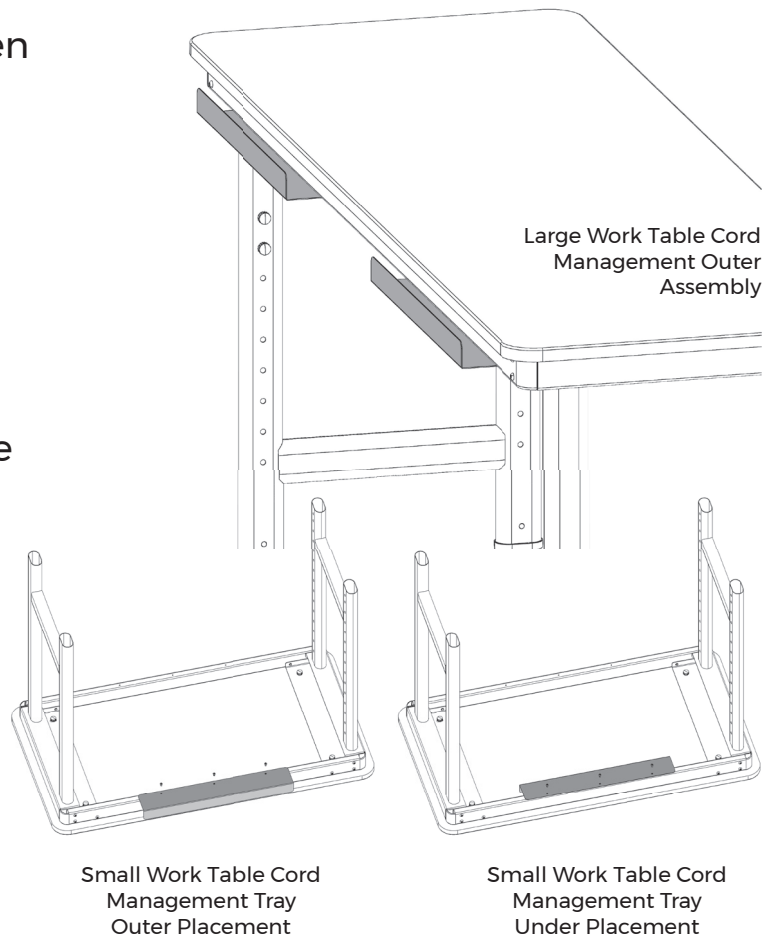

## STEP 5

Each leg has 2 Thumb Screws **(C)** to adjust the Work Table height.

The Work Table ranges from 32" to 44.5" height at 1.8" increments.

In either position, the Work Table legs may be adjusted, though it is recommended to adjust with the table upside down.

To adjust the work table height, remove the Thumb Screws and slide the inner leg at the bottom up/down to the designated height. Tighten the Thumb Screws to secure. Continue this process with each, adjusting and measuring, until the table is at the perfect height.

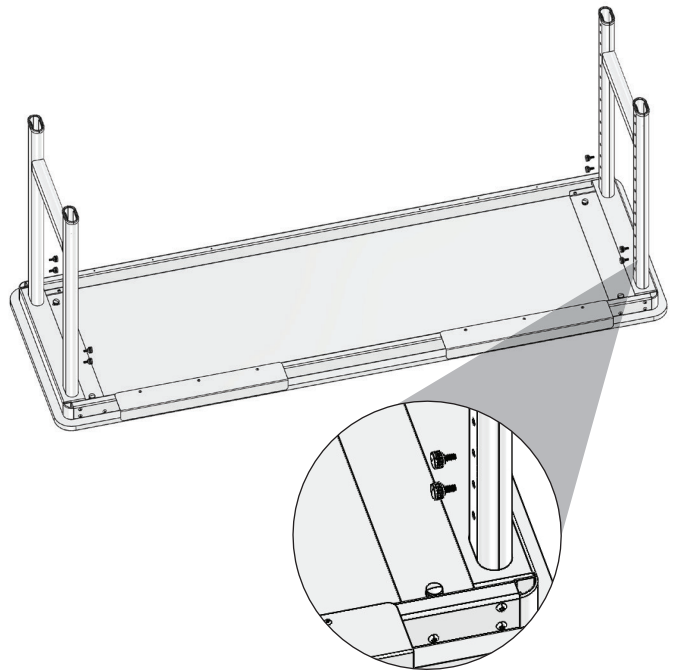

## STEP 6

Have a friend or family member assist to carefully flip the Work Table to the upright position and move to the desired location.

To ensure your table sits level, simply twist the leveling feet at the bottom of each table leg, either clockwise or counter-clockwise, depending on whether you need to raise or lower that corner of the table. It's advisable to place a level on the table's surface to accurately gauge when the table is perfectly horizontal. Adjust each foot incrementally, checking the level after each adjustment, until the bubble is centered, indicating that the table is perfectly level. This extra step ensures your workspace is not only ergonomically aligned but also safe, stable and secure for all types of tasks.

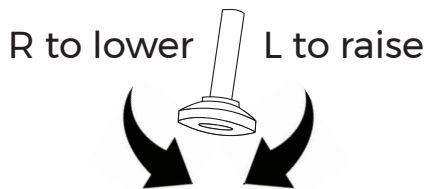
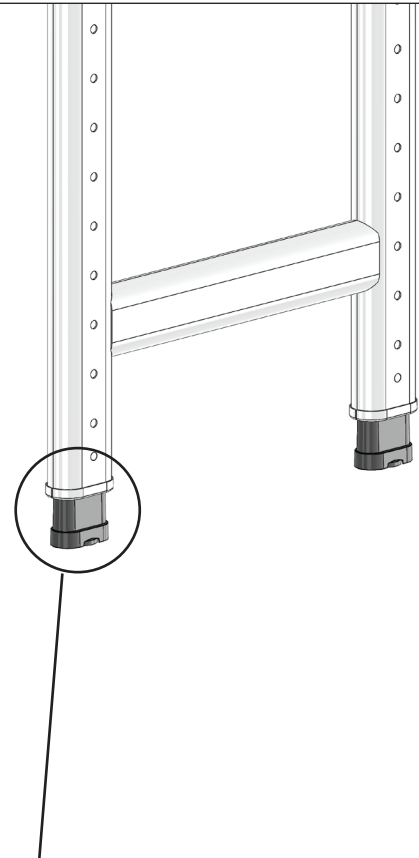

Leveling Caps are pre-installed on your Work Table. After adjusting the leveling feet, slide the Leveling Caps up/down for a seamless look at the floor surface.

Ready for use!

## CLEANING

Wipe with soft cloth and a mild dish soap to keep work tables clean.  
Dry immediately with a soft, clean cloth.

### CONTACT INFORMATION

EVEREST WORLD HEADQUARTERS  
Kindred Products LLC  
2460 M-139 Suite B  
Benton Harbor, MI 49022-6444

Mailing Address  
P.O. Box 827  
Saint Joseph, MI 49085-0827

Customer Service  
Phone: (866) 456-0866  
Email: [customerservice@kindredproducts.net](mailto:customerservice@kindredproducts.net)  
Website: [www.Everesthome.com](http://www.Everesthome.com)

Scan for  
Warranty  
Information



Warning and Disclaimer: Kindred LLC Expressly disclaims all liability for personal injury, property damage or loss, whether direct, indirect, incidental, resulting from incorrect assembly, improper use, inadequate maintenance, or neglect. 2024 Kindred. All rights reserved.

P/N: 38010408202-02 (September 2024)