

CRYSTORAMA

LIGHTING THE WAY FOR SIXTY YEARS

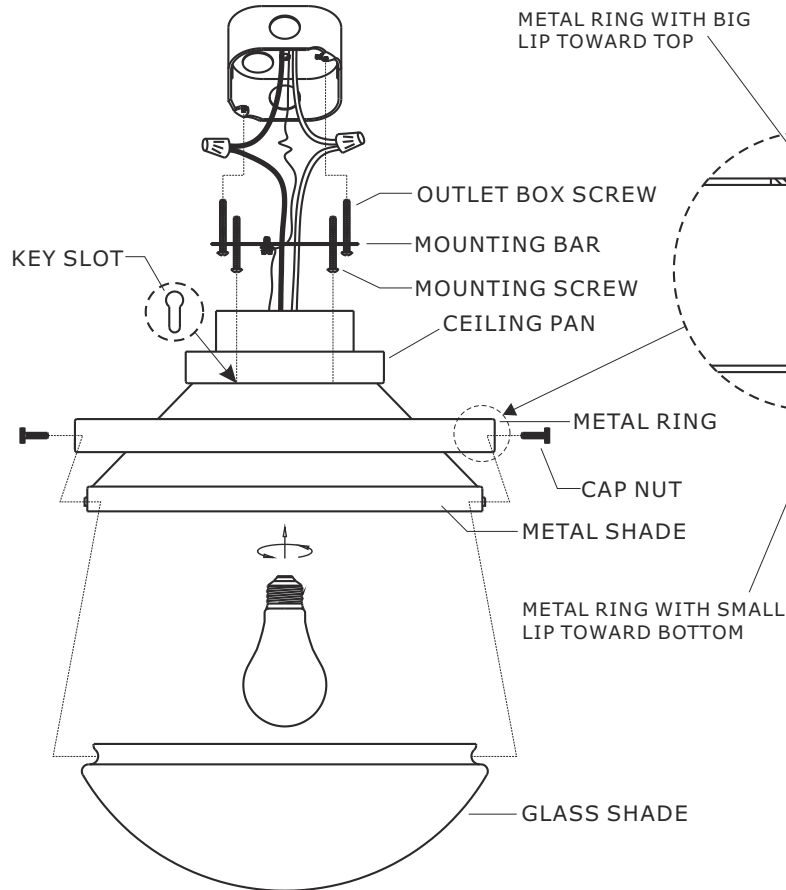

ASSEMBLY INSTRUCTION MODEL#XAN-8001-VG-WH



All electrical components must be installed by a licensed electrician in accordance with the National Electric Code and the appropriate local electrical codes.



You will need 1-Medium Base Bulb
40 Watts Recommended 60 Watts Max.
USE LED BULBS FOR EXTENDED USE
This fixture is Damp rated

How to install

1. Slide the metal ring over the metal shade and line up the holes on the metal ring with holes on the metal shade, then secure with cap nut. Please do not screw the cap nut all the way down. Just keep 2-3 threads exposed beyond the inner frame.
2. Thread the mounting screws into the matching holes in the mounting bar. Secure the mounting bar to outlet box with the outlet box screws.
3. Connect fixture wires to supply wires in outlet box.
4. Raise the ceiling pan allowing for the mounting screws to protrude through key slots on the ceiling pan. Rotate the ceiling pan clockwise until the mounting screws are in the narrow parts of the key slot then tighten the screws with a screw driver.
5. Install the bulb(not included) into the socket.
6. Raise the glass shade into the frame and tighten it using the screws, it may be required to adjust the cap nuts slightly to keep the glass shade in the center of the frame.

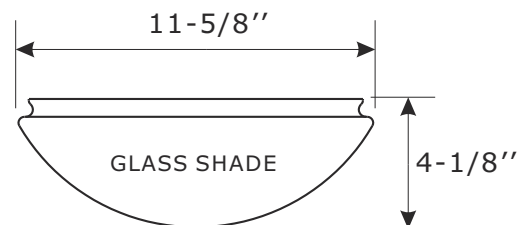
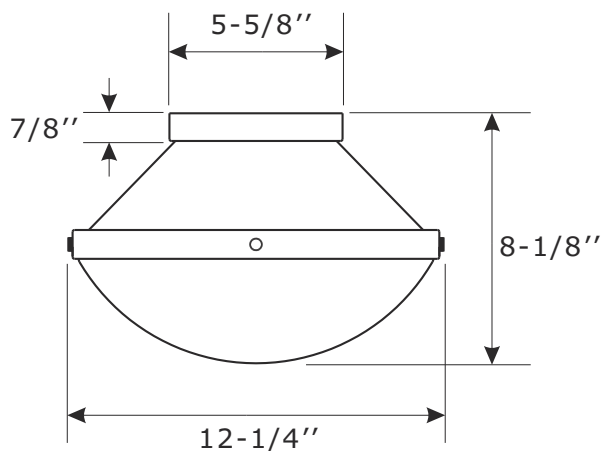

WARNING: This product can expose you to Lead which is known to the state of California to cause cancer and/or birth defects or reproductive harm. For more information go to www.P65Warnings.ca.gov



Part Number

Part Numbers

- A. (1)-Mounting hardware
- B. (1)-Ceiling pan
- C. (1)-Metal ring
- D. (3)-Cap nut
- E. (1)-Glass shade #XRF8001GLA12IN

