

SensXtend Accessory Specifications

Leak & Temperature Sensor Specifications

Application

LeakSmart® Sensor protects your most high risk areas; including washing machines, water heaters, bathrooms, and HVAC units. Designed to fit into tight spaces, without shifting or sliding. The sensors send the signal to immediately detect leaks, temperature, humidity & sensor movement as a stand-alone sensor or to shut off water within 5 seconds when added to a Protect by LeakSmart valve system & alerts you through the free LeakSmart app via Wi-Fi communication.

Features

- Wi-Fi Communication
- Battery power
- LED status light, visual alarm
- Audible Alarm
- 5-year manufacturer's warranty*

Product Specifications

- Frequency: 2405 to 2480 MHz
- Operating Temperature: -22° F -158° F (-30° C to 70° C)
- Battery Size: AA (included)
- Battery Life: 12 - 18 Months

Materials

High performance engineered polymer

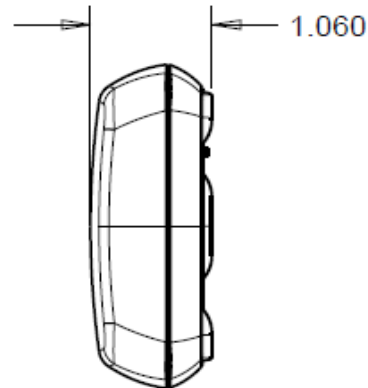
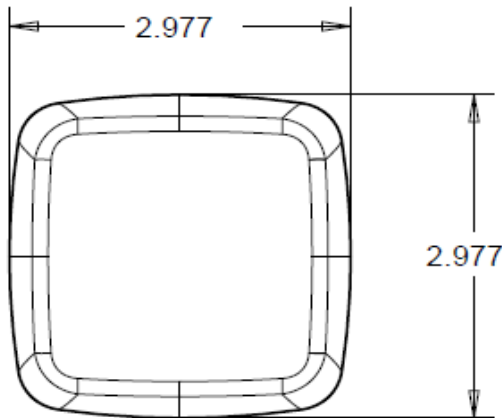

* Dimensions for reference

Approvals



* 5-year manufacturer's warranty when purchased and installed by a professional installer.

SensXtend Accessory Specifications

Sensor Dock

Application

The patented sensor dock connects the LeakSmart Sensor to the SensXtend extension cable and rope sensor, providing customizable extended leak protection. The sensor dock provides 3 separate ports to allow 3 rope extensions to cover surface area in 3 separate directions.

Product Specifications

Input Ports (3): 3.5 Audio Jack, Nickel-Plated

Materials

ABS

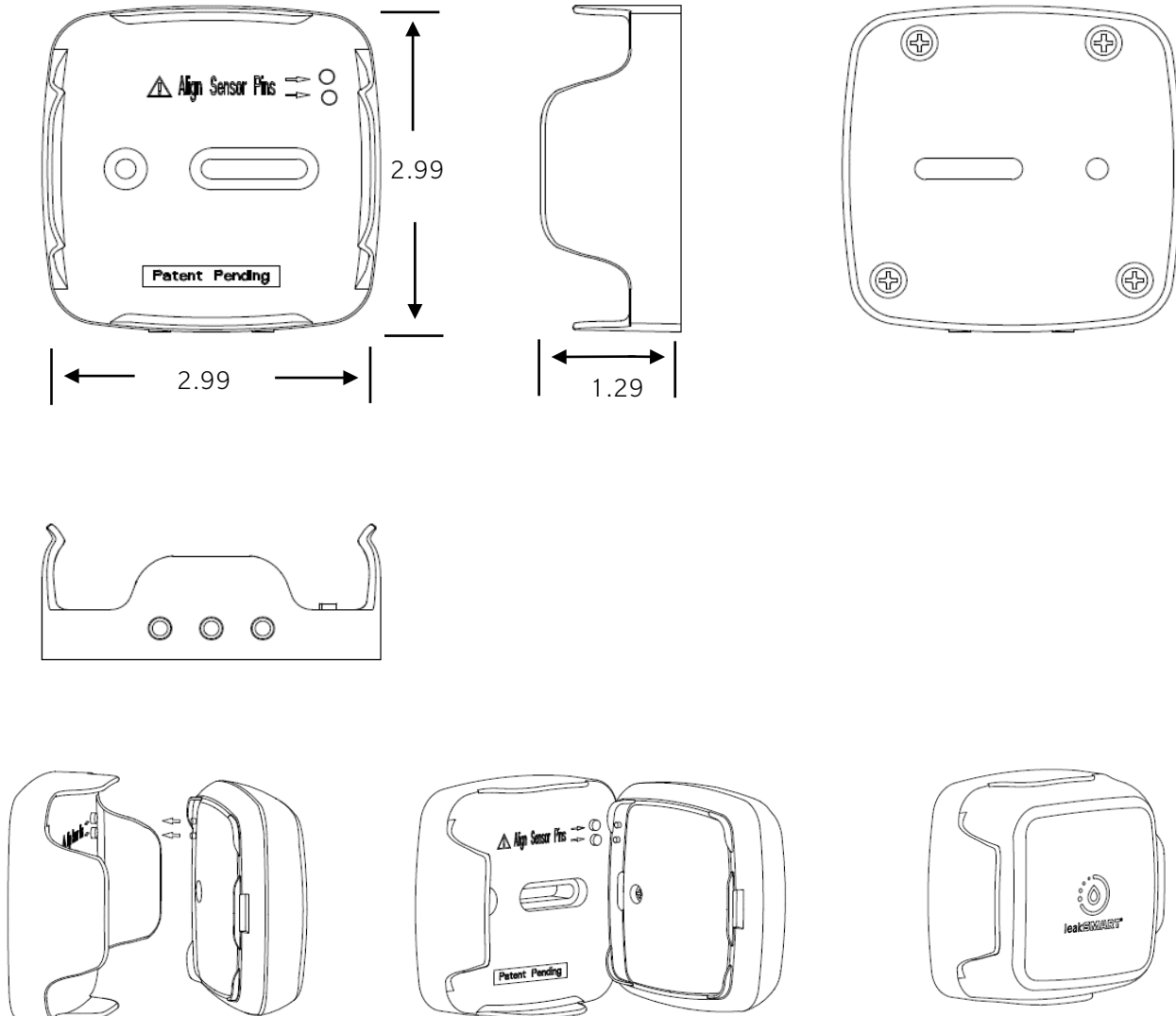

SensXtend Accessory Specifications

Extension Cable

Application

The extension cable is an optional cable that is used to extend the reach of the rope sensor. It does not detect water leaks, so it's intended to be used in areas where leak detection is necessary so that the full length of the rope sensor can be maximized where it's needed most.

Product Specifications

Plug 1: 3.5 Audio Jack, Nickel-Plated

Plug 2: 3.5 Stereo Three Pole, Nickel-Plated

Materials

PVC

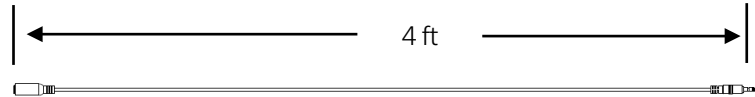
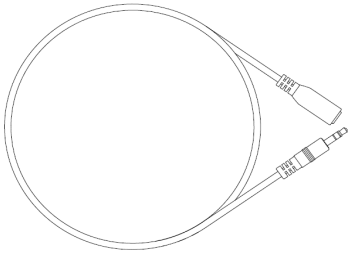

Rope Sensor

Application

The rope sensor detects water leaks along its entire 4 foot length when plugged directly into the sensor dock or when it is connected to an extension cable that is plugged into a sensor dock.

Product Specifications

Plug 1: 3.5 Audio Jack, Nickel-Plated

Plug 2: 3.5 Stereo Three Pole, Nickel-Plated

Conductor Resistance: 3 ohms Max

Insulation Resistance: 10M ohms Min

Leak Detection Length: Along entire 4' surface (not including plugs); can connect up to 25 ropes for 100' per line or 300' per sensor dock

Materials

Black & White Spiral PVC

