



HardieTrim® Boards

EFFECTIVE SEPTEMBER 2019

These instructions are to be used for HardieTrim® HZ™ Boards ONLY and are **ONLY VALID** in the following states: WA, OR, CA, NV, UT, ID, CO, WY, MT, AZ, NM.

IMPORTANT: FAILURE TO FOLLOW JAMES HARDIE WRITTEN INSTALLATION INSTRUCTIONS AND COMPLY WITH APPLICABLE BUILDING CODES MAY VIOLATE LOCAL LAWS, AFFECT BUILDING ENVELOPE PERFORMANCE AND MAY AFFECT WARRANTY COVERAGE. FAILURE TO COMPLY WITH ALL HEALTH AND SAFETY REGULATIONS WHEN CUTTING AND INSTALLING THIS PRODUCT MAY RESULT IN PERSONAL INJURY. BEFORE INSTALLATION, CONFIRM YOU ARE USING THE CORRECT HARDIEZONE® PRODUCT INSTRUCTIONS BY VISITING HARDIEZONE.COM OR CALL 1-866-942-7343 (866-9-HARDIE)

STORAGE & HANDLING:

Store flat and keep dry and covered prior to installation. Installing siding wet or saturated may result in shrinkage at butt joints. Carry planks on edge. Protect edges and corners from breakage. James Hardie is not responsible for damage caused by improper storage and handling of the product.

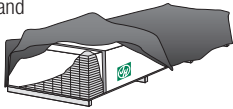

CUTTING INSTRUCTIONS

OUTDOORS

1. Position cutting station so that airflow blows dust away from the user and others near the cutting area.
2. Cut using one of the following methods:
 - a. Best: Circular saw equipped with a HardieBlade® saw blade and attached vacuum dust collection system. Shears (manual, pneumatic or electric) may also be used, not recommended for products thicker than 7/16 in.
 - b. Better: Circular saw equipped with a dust collection feature (e.g. Roan® saw) and a HardieBlade saw blade.
 - c. Good: Circular saw equipped with a HardieBlade saw blade.

INDOORS

DO NOT grind or cut with a power saw indoors. Cut using shears (manual, pneumatic or electric) or the score and snap method, not recommended for products thicker than 7/16 in.

- DO NOT dry sweep dust; use wet dust suppression or vacuum to collect dust.
- For maximum dust reduction, James Hardie recommends using the "Best" cutting practices. Always follow the equipment manufacturer's instructions for proper operation.
- For best performance when cutting with a circular saw, James Hardie recommends using HardieBlade® saw blades.
- Go to jameshardiepros.com for additional cutting and dust control recommendations.

IMPORTANT: The Occupational Safety and Health Administration (OSHA) regulates workplace exposure to silica dust. For construction sites, OSHA has deemed that cutting fiber cement with a circular saw having a blade diameter less than 8 inches and connected to a commercially available dust collection system per manufacturer's instructions results in exposures below the OSHA Permissible Exposure Limit (PEL) for respirable crystalline silica, without the need for additional respiratory protection.

If you are unsure about how to comply with OSHA silica dust regulations, consult a qualified industrial hygienist or safety professional, or contact your James Hardie technical sales representative for assistance. James Hardie makes no representation or warranty that adopting a particular cutting practice will assure your compliance with OSHA rules or other applicable laws and safety requirements.

HardieTrim® boards are decorative non-load bearing trim products.

Do not use HardieTrim boards to replace any structural component.

TABLE OF CONTENTS

GENERAL REQUIREMENTS	Page 1
FLASHING/CLEARANCE REQUIREMENTS	Page 2
FASTENING	Page 3
Face Nailing Requirements.....	Page 3
INSTALLATION	Page 4-8
Trimming Corners.....	Page 4
Openings.....	Page 4
Band Boards.....	Page 4
Frieze.....	Page 4
Batten Boards.....	Page 5
Fascia.....	Page 6
HardieTrim™ Tabs.....	Page 7-8
FINISHING	Page 9

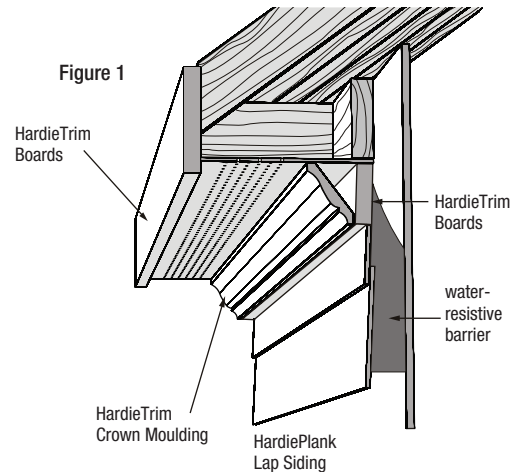

GENERAL REQUIREMENTS

- Wood or steel must be provided for attaching HardieTrim boards.
- Follow all applicable codes when installing HardieTrim boards.
- DO NOT install HardieTrim boards, such that they may remain in contact with standing water.
- DO NOT use stain, oil/alkyd base paint, or powder coating on James Hardie Products.





FLASHING/CLEARANCE REQUIREMENTS NO-COVER

HardieTrim may be installed with a minimum 1/4 in. clearance when installed vertically to grade, decks, paths, steps, and driveways

Maintain a minimum 1 in. horizontal clearance between James Hardie trim products and decks, paths, steps and driveways.

At the juncture of the roof and vertical surfaces, flashing and counter flashing shall be installed per the roofing manufacturer's instructions. Provide a 1 in. clearance between the roofing and the bottom edge of the trim.

Figure 2

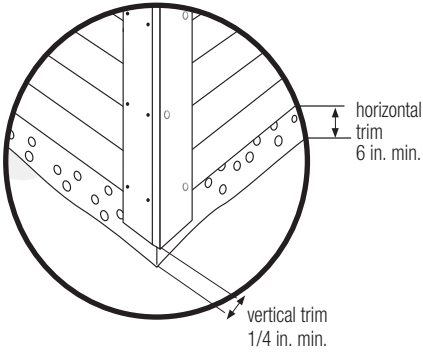

Figure 3

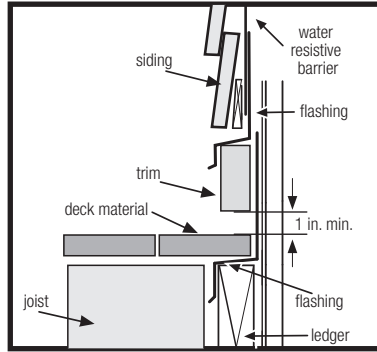
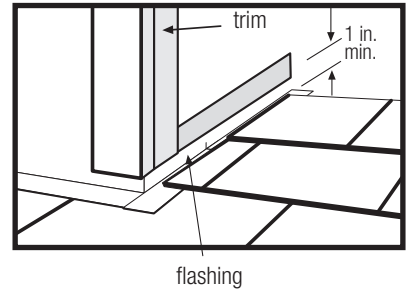
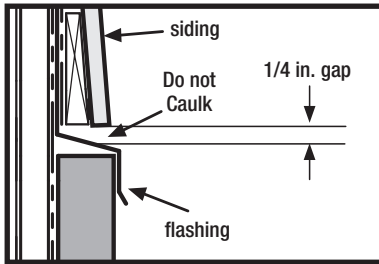

Figure 4



Maintain a 1/4 in. clearance between the bottom of James Hardie products and horizontal flashing. Do not caulk gap.

Figure 5



Drip Edge

Figure 6 for fascia installation see page 6

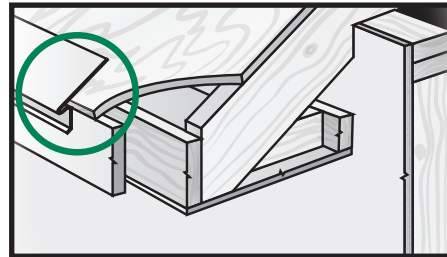

Mortar/Masonry

Figure 7

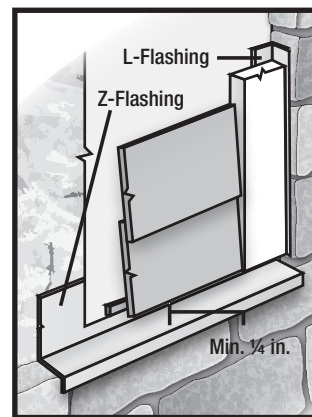

Block Penetration

(recommended in HZ10)

Figure 8

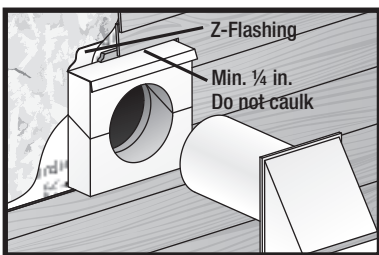

Valley/Shingle Extension

Figure 9

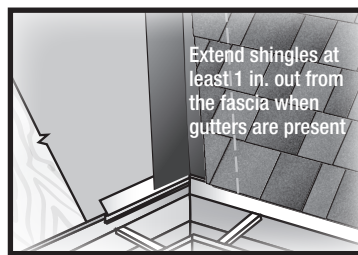

CLEARANCE REQUIREMENTS UNDER-COVER

Maintain a 1/4 in. clearance for HardieTrim boards installed under cover. Under cover is defined as:

- Not more than 10 feet below a roof overhang, and
- Not less than 4 inches horizontally from the edge of the roof overhang

Figure 10

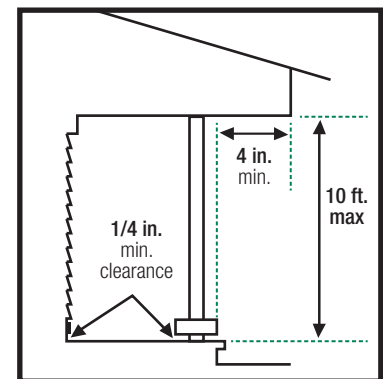



GENERAL FASTENING REQUIREMENTS

Fasteners must be corrosion resistant, galvanized, or stainless steel. Electro-galvanized are acceptable but may exhibit premature corrosion. James Hardie recommends the use of quality, hot-dipped galvanized nails. James Hardie is not responsible for the corrosion resistance of fasteners. Stainless steel fasteners are recommended when installing James Hardie products near the ocean, large bodies of water, or in very humid climates.

Manufacturers of ACQ and CA preservative-treated wood recommend spacer materials or other physical barriers to prevent direct contact of ACQ or CA preservative-treated wood and aluminum products. Fasteners used to attach HardieTrim Tabs to preservative-treated wood shall be of hot dipped zinc-coated galvanized steel or stainless steel and in accordance to 2009 IRC R317.3 or 2009 IBC 2304.9.5.”

PNEUMATIC FASTENING

James Hardie products can be hand nailed or fastened with a pneumatic tool. Pneumatic fastening is highly recommended. Set air pressure so that the fastener is driven snug with the surface of the trim. A flush mount attachment on the pneumatic tool is recommended. This will help control the depth the nail is driven. If setting the nail depth proves difficult, choose a setting that under drives the nail. (Drive under driven nails snug with a smooth faced hammer - Does not apply for installation to steel framing).

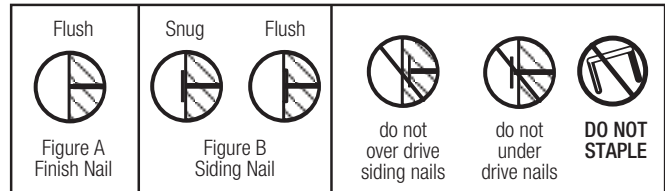

FACE NAILING REQUIREMENTS

Use 2 in. minimum 16 ga. finish nails to attach HardieTrim boards to wood frame construction. ET&F or equivalent fasteners or screws may be used to attach HardieTrim boards to steel frame construction.

Fastening instructions are similar for all applications. When using finish nails, position nails no closer than 1/2 in. from the edges of the trim and for all other fasteners no closer than 3/4 in. Fasteners must be no closer than 1 in. from ends of trim and spaced a maximum of 16 in. O.C. Ensure trim is adequately fastened.

James Hardie recommends using stainless steel finish nails when installing HardieTrim products.

Minimum fastener guide for finish nailing:

	Pre-built corner	Site Built Corners	Other areas (e.g. window trim, and band boards)
4 in.	1 nail every 16 in. to attach boards together + 1 nail every 16 in. each board	2 nails every 16 in.	2 nails every 16 in.
6 in.	1 nail every 16 in. to attach boards together + 2 nails every 16 in. each board		
8 in.	-	3 nails every 16 in.	3 nails every 16 in.
12 in.	-	4 nails every 16 in.	3 nails every 16 in.

Use a 2 in. finish nail to fasten trim together. Longer finish nails may bend.

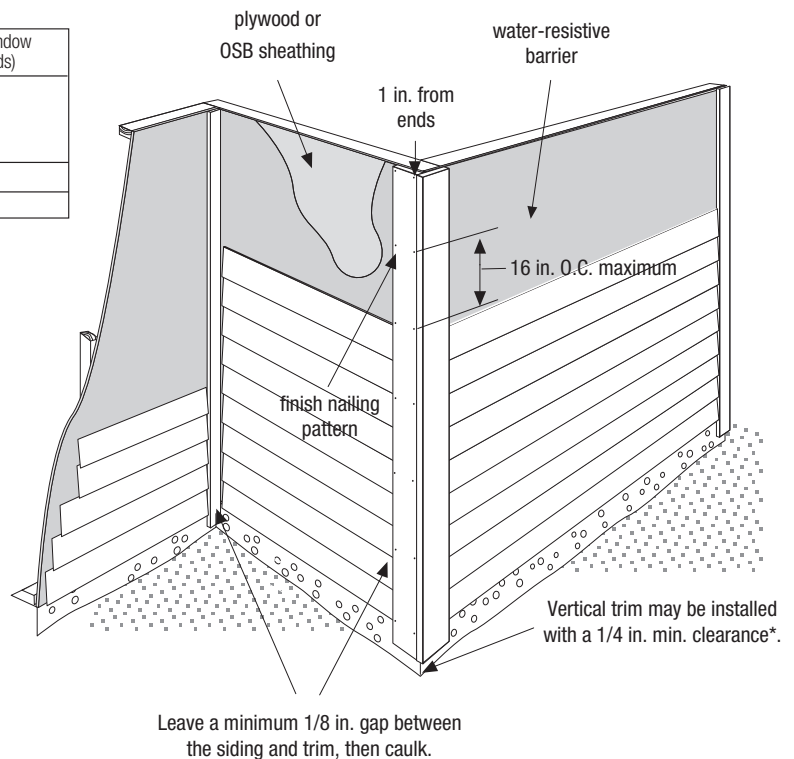

Figure 11

*Follow all applicable codes when installing HardieTrim boards



INSTALLATION

TRIMMING CORNERS

When installing corners or other vertical trim, position boards on the wall and attach (figure 12).

Pre-Built Corners

Alternatively, corners can be pre-built off the wall using 2 in. finishing nails. Each side of the pre-built corner must be secured to the wall (figure 13).

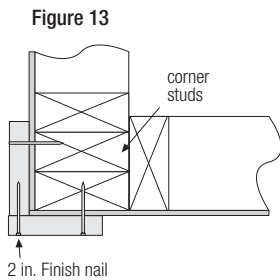
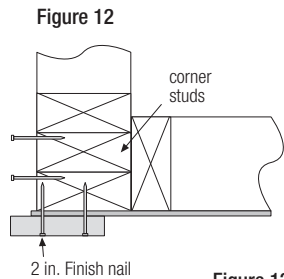

TRIM APPLICATION FOR WINDOWS, DOORS & OTHER OPENINGS

Flashing over trim is required per code for all installation methods. (figure 14)

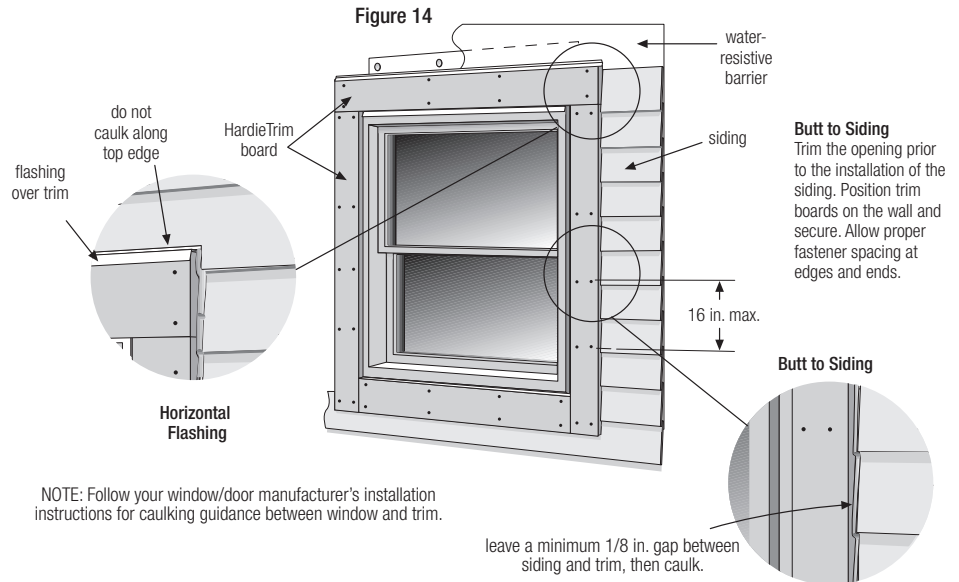

NOTE: Follow your window/door manufacturer's installation instructions for caulking guidance between window and trim.

BAND BOARD

For band board applications, a flashing is required over the trim. (figure 15)

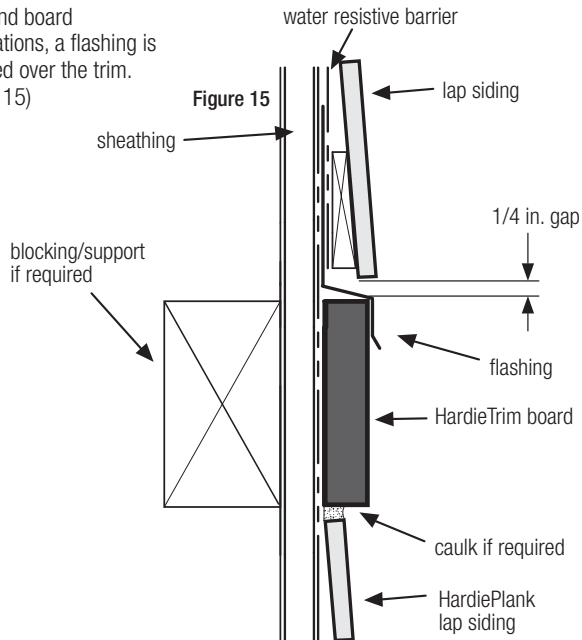

FRIEZE BOARDS

HardieTrim boards can be used as frieze board. (figure 16)

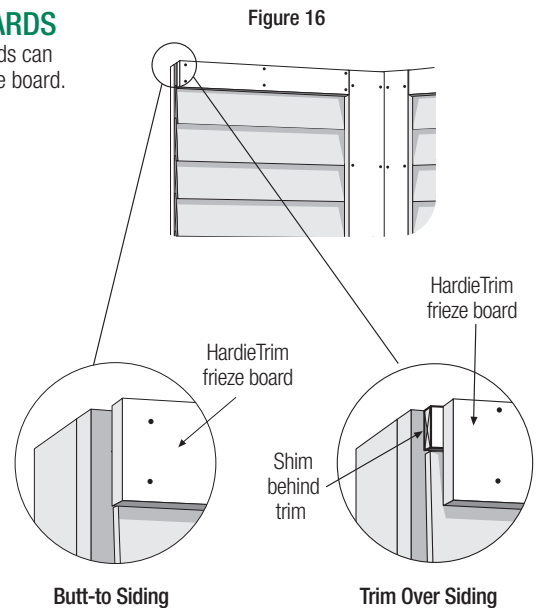



BATTEN BOARDS

HORIZONTAL PANEL JOINTS

At horizontal panel joints HardieTrim battens must be installed according to option 1 or 2 below. When installing HardieTrim Battens horizontally, they must be installed as a panel joint according to option 2.

Option 1

Figure 17 - No horizontal band board - Make a 22.5 - 45 degree weather cut, in the HardieTrim batten, just above the 1/4 in. clearance between panels.

Option 2

Figure 18 - Horizontal Band Board - Install a horizontal band board at the top of the bottom panel. Butt the lower batten to the band board and start the top batten at the bottom edge of the top panel. Maintain a 1/4 in. clearance above horizontal flashing.

Figure 17

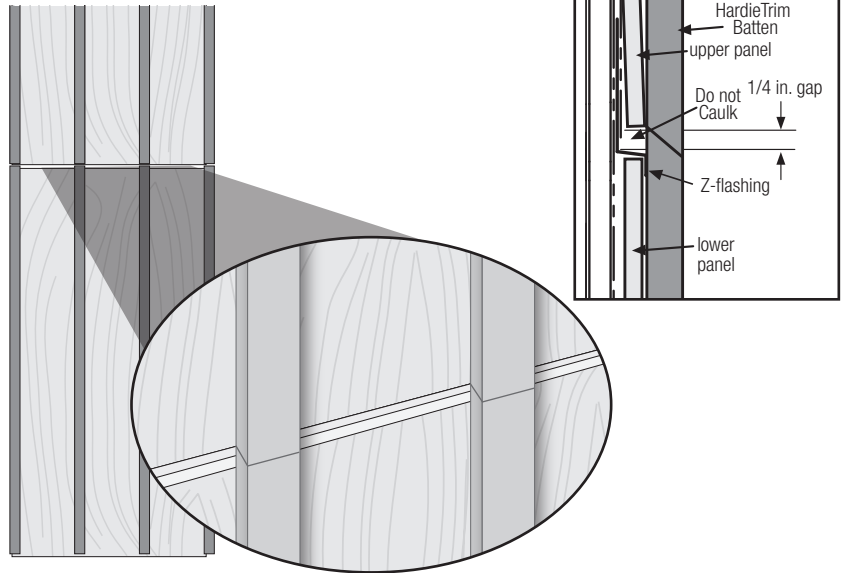
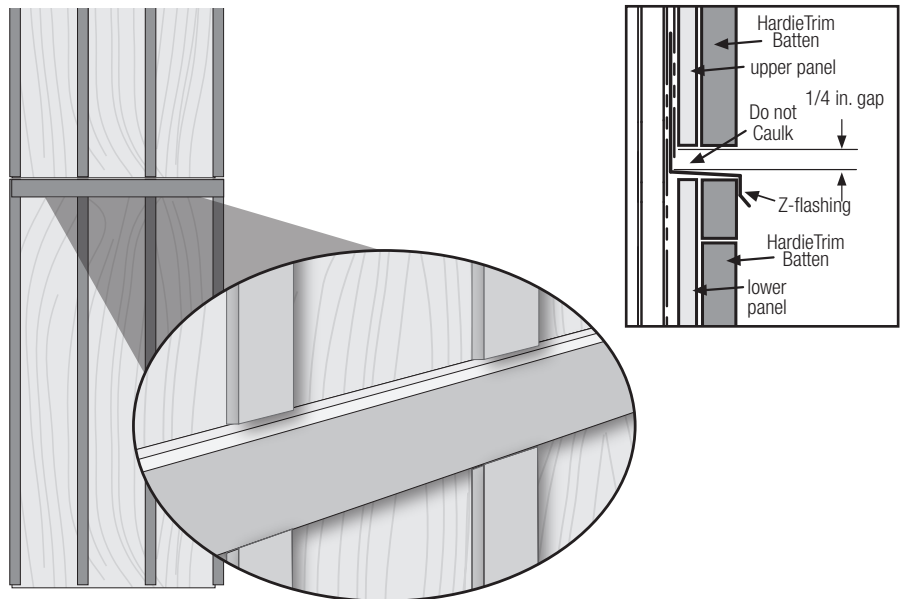

Figure 18





FASCIA

HardieTrim board is a decorative non-load bearing trim product. Do not use HardieTrim to replace any structural component.

HardieTrim boards can be fastened directly over a 2x sub-fascia or directly to rafter tails. Check local building code for relevant codes.

Option 1

Over sub-fascia: (figure 19)

When installing HardieTrim boards over solid 2x sub-fascia use minimum 2 in., 16 gauge corrosion resistant finish nails. (see fastener guide below)

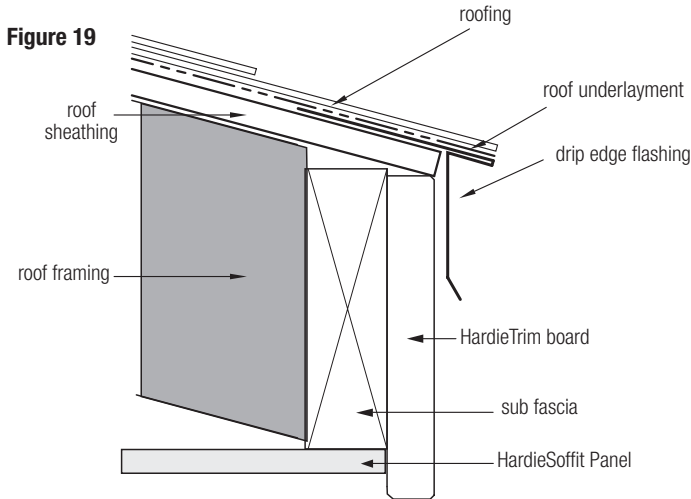

Gutters:

James Hardie recommends the use of rain gutters whenever possible.

Do not attach gutters directly to HardieTrim

Use gutter hangers that attach through the roof sheathing into a rafter tail or other structural member.

Soffit

When installing HardieSoffit additional framing/blocking may be needed depending on application. Refer to HardieSoffit installation instructions for guidance.

Option 2

Direct to rafter tails: (figure 20)

When installing HardieTrim boards without the presence of a 2x sub-fascia, a minimum 8d siding corrosion resistant nails must be used to attach HardieTrim boards DO NOT use finish nails. (refer to fastener guide below).

Fascia Fastener Guide

HardieTrim Board	FASTENER SPACING	
	Direct to Rafter (min 8d siding)	Over 2x Sub-fascia (Minimum 2 in. 16 ga. Finish nails)
6 in.	2 nails every rafter spaced max 24 in. O.C.	2 nails spaced maximum 16 in. O.C.
8 in.	3 nails every rafter spaced max 24 in. O.C.	3 nails spaced maximum 16 in. O.C.
10 in.		4 nails spaced maximum 16 in. O.C.

Figure 20

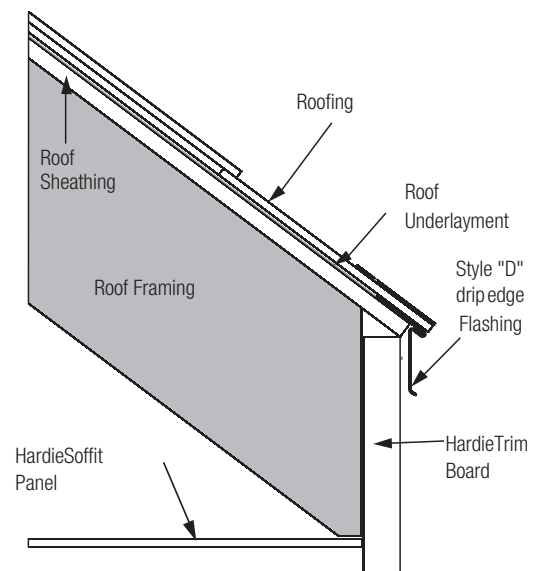



HARDIETRIM® TABS

FASTENER REQUIREMENTS

For Corners, Band Boards, Windows, and Door Applications:

HardieTrim boards may be installed with HardieTrim™ Flat Tabs and HardieTrim™ Corner Tabs which provide concealed fastening. Only HardieTrim Flat and Corner Tabs can be used with HardieTrim boards to create a concealed fastening.

Step 1: Attach HardieTrim Flat Tabs to the back side of the trim using four, 18 ga. 1/2 in. L x 1/4 in. W narrow crown corrosion resistant staples, equally spaced in one row, positioned no closer than 1/2 in. from trim edges using a pneumatic staple gun. (figures 21, 22)

Step 2: For wood frame construction, attach the trim to the building with minimum 2, 6d siding nails fastened through the HardieTrim Flat Tabs (figure 23). ET&F or equivalent fasteners may be used to attach the HardieTrim Flat Tabs to steel frame construction.

Fastener spacing will vary based on application. Refer to fastener table on page 9. Refer to specific sections in these instructions for required fastener spacing by application (window, band board, etc.)

For Fascia, Rake, and Frieze board Applications:

HardieTrim tabs cannot be used in fascia, rake, or frieze board applications. Follow Face nailing fastening specifications.

Installation of HardieTrim tabs in Coastal Regions:

James Hardie requires that stainless steel staples & fasteners be used when installing HardieTrim Tabs in coastal regions.

Installation of HardieTrim Tabs over Pressure Treated Lumber: HardieTrim tabs **shall not** come in direct contact with ACQ or CA preservative-treated wood. Refer to the General Fastening section of this document for further information.

HardieTrim boards with ColorPlus Technology: Remove the laminate sheet as soon as possible after attaching the trim to the building.

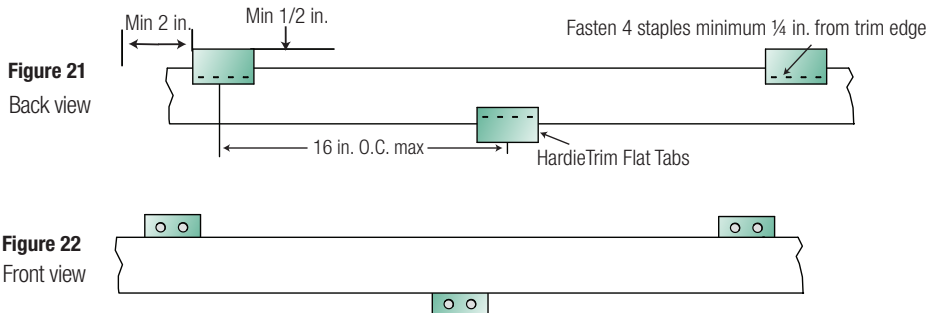

Figure 23

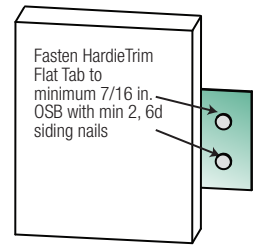
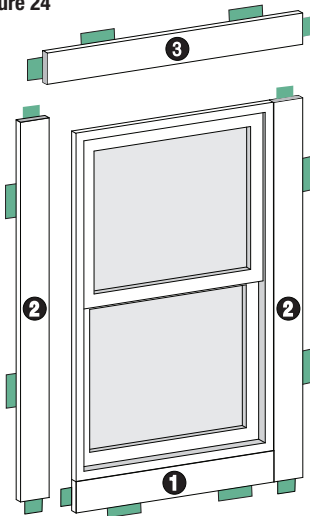
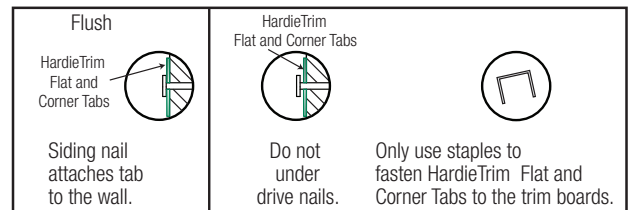

Figure 24



Trim Application for Windows, Doors & Other Openings

Trim the opening prior to the installation of the siding. Place a Flat Tab at the end of each trim board and one tab every 16 in. OC. Attach the trim boards and Flat Tabs around the opening as shown in figure 24. Use 16 ga. galvanized 2 in. long finish nails to ensure proper fastening if needed.



NOTE: Follow your window/door manufacturers installation instructions for caulking guidance between window and trim.





TRIMMING CORNERS

When using HardieTrim tabs prebuild outside corners off the wall.

- Attach HardieTrim Corner Tabs to the back side of the trim using eight(8) - 18 ga. 1/2 in. L x 1/4 in. W narrow crown corrosion resistant staples using a pneumatic stapler. Ensure the HardieTrim Corner Tabs are fastened tight and straight to the trim boards. (figure 25)
- For wood frame construction, attach trim to building using min. 6d siding nails fastened through the HardieTrim Corner Tabs attached to minimum 7/16 in. OSB *. (figure 26)
- Attach a HardieTrim Corner Tab 1 in. from each ends and every 20 in. O.C.
- TIP: Creating a jig for the work station is recommended to ensure corners are fastened securely and straight. (figure 27)

Figure 25

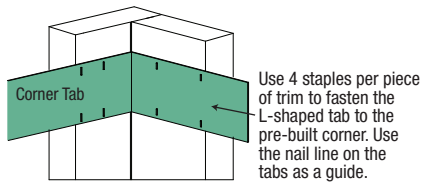

Figure 26

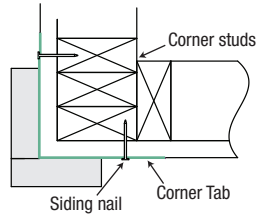
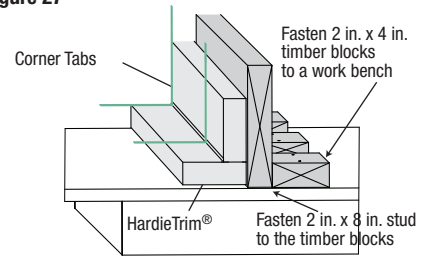

Figure 27



BAND BOARD

Terminate ends of the Band Board into Trim or Siding or miter cut the edges of the trim at the corners of the building. Place a HardieTrim Flat Tab at the end of each trim board and one tab every stud at a maximum of 16 in. O.C. The HardieTrim Flat Tabs should be attached to the trim in an alternating pattern to the top and bottom of the band board (figures 21, 22). Use 16 ga. galvanized 2 in. long finish nails to ensure proper fastening if needed.

Trim Tab Fastener Table

Application	Framing Material Tab is nailed into	Fastener (tab to framing)	Fastener (tab to trim)	Max Tab Spacing (inches on center)
Flat Tab	Wood Stud (minimum G=0.42)	One 6d corrosion resistant siding nail installed through center of tab into framing	Four 18 ga. X 1/2 in. long X 1/4 in. wide corrosion resistant crown staples, equally spaced in one row	16
	Minimum APA rated 7/16 in. OSB	Two 4d ring shank corrosion resistant siding nails equally spaced installed through tab into framing		
	Minimum 20 gauge steel	One No. 8 X 1 in. long X 0.323 in. head diameter screw (corrosion resistant) installed through flange into framing		
Corner Tab	Wood Stud (minimum G=0.42)	On each flange, Install one 6d corrosion resistant siding nail through tab into framing	For each piece of trim, install Four 18 ga. X 1/2 in. long X 1/4 in. wide corrosion resistant crown staples, equally space in two rows	20
	Minimum APA rated 7/16 in. OSB	On each flange, Install two 4d ring shank corrosion resistant siding nails through tab into framing		
	Minimum 20 gauge steel	On each flange, Install one No. 8 X 1 in. long X 0.323 in. head diameter screw (corrosion resistant) through tab into framing		





FINISHING

CUT EDGE TREATMENT

Caulk, paint or prime all field cut edges. James Hardie touch-up kits are required to touch-up ColorPlus products.

CAULKING

For best results use an Elastomeric Joint Sealant complying with ASTM C920 Grade NS, Class 25 or higher or a Latex Joint Sealant complying with ASTM C834. Caulking/Sealant must be applied in accordance with the caulking/sealant manufacturer's written instructions.

PAINTING

DO NOT use stain, oil/alkyd base paint, or powder coating on James Hardie Products. James Hardie products must be painted within 180 days for primed product and 90 days for unprimed. 100% acrylic topcoats are recommended. Do not paint when wet. For application rates refer to paint manufacturers specifications. Back-rolling is recommended if the siding is sprayed.

COLORPLUS TECHNOLOGY CAULKING, TOUCH-UP & LAMINATE

- Care should be taken when handling and cutting James Hardie® ColorPlus® products. During installation use a wet soft cloth or soft brush to gently wipe off any residue or construction dust left on the product, then rinse with a garden hose.
- Touch up nicks, scrapes and nail heads using the ColorPlus® Technology touch-up applicator. Touch-up should be used sparingly. If large areas require touch-up, replace the damaged area with new HardiePlank® lap siding with ColorPlus® Technology.
- Laminate sheet must be removed immediately after installation of each course.
- Terminate non-factory cut edges into trim where possible, and caulk. Color matched caulks are available from your ColorPlus® product dealer.
- Treat all other non-factory cut edges using the ColorPlus Technology edge coat, available from your ColorPlus product dealer.

Note: James Hardie does not warrant the usage of third party touch-up or paints used as touch-up on James Hardie ColorPlus products.

Problems with appearance or performance arising from use of third party touch-up paints or paints used as touch-up that are not James Hardie touch-up will not be covered under the James Hardie ColorPlus Limited Finish Warranty.

PAINTING JAMES HARDIE SIDING AND TRIM PRODUCTS WITH COLORPLUS TECHNOLOGY

When repainting ColorPlus products, James Hardie recommends the following regarding surface preparation and topcoat application:

- Ensure the surface is clean, dry, and free of any dust, dirt, or mildew
- Repriming is normally not necessary
- 100% acrylic topcoats are recommended
- DO NOT use stain, oil/alkyd base paint, or powder coating on James Hardie® Products.
- Apply finish coat in accordance with paint manufacturers written instructions regarding coverage, application methods, and application temperature
- DO NOT caulk nail heads when using ColorPlus products, refer to the ColorPlus touch-up section

TR1509_P9/9 09/19

SILICA WARNING

DANGER: May cause cancer if dust from product is inhaled. Causes damage to lungs and respiratory system through prolonged or repeated inhalation of dust from product. Refer to the current product Safety Data Sheet before use. The hazard associated with fiber cement arises from crystalline silica present in the dust generated by activities such as cutting, machining, drilling, routing, sawing, crushing, or otherwise abrading fiber cement, and when cleaning up, disposing of or moving the dust. When doing any of these activities in a manner that generates dust you must (1) comply with the OSHA standard for silica dust and/or other applicable law, (2) follow James Hardie cutting instructions to reduce or limit the release of dust; (3) warn others in the area to avoid breathing the dust; (4) when using mechanical saw or high speed cutting tools, work outdoors and use dust collection equipment; and (5) if no other dust controls are available, wear a dust mask or respirator that meets NIOSH requirements (e.g. N-95 dust mask). During clean-up, use a well maintained vacuum and filter appropriate for capturing fine (respirable) dust or use wet clean-up methods - never dry sweep.

WARNING: This product can expose you to chemicals including respirable crystalline silica, which is known to the State of California to cause cancer. For more information go to P65Warnings.ca.gov.

RECOGNITION: In accordance with ICC-ES Evaluation Report ESR-2290, HardiePlank® lap siding is recognized as a suitable alternate to that specified in: the 2006, 2009, & 2012 International Residential Code for One- and Two-Family Dwellings, and the 2006, 2009, & 2012 International Building Code. HardiePlank lap siding is also recognized for application in the following: City of Los Angeles Research Report No. 24862, State of Florida listing FL#889, Dade County, Florida NOA No. 02-0729.02, U.S. Dept. of HUD Materials Release 1263c, Texas Department of Insurance Product Evaluation EC-23, City of New York MEA 223-93-M, and California DSA PA-019. These documents should also be consulted for additional information concerning the suitability of this product for specific applications.