

**TWIN / FULL BUNK BED**  
**LIT SUPERPOSABLE JUMEAU / DOUBLE**  
**LITERA GEMELA / DOBLE**

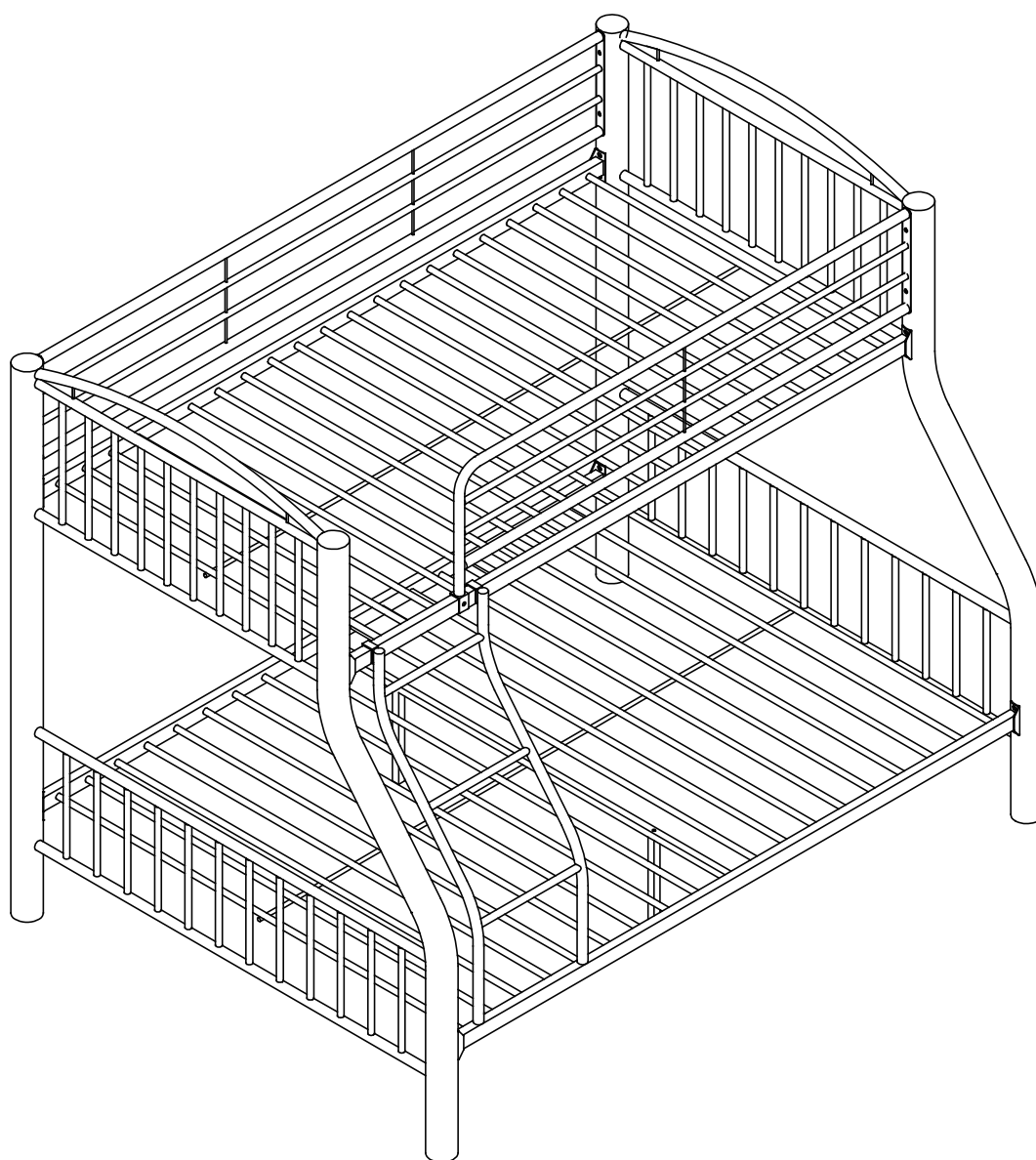

**YZ - 7575 - CN**

## **We are here to help!**

### **Before you return it - contact us.**

We do our best to insure that your furniture arrives in excellent condition. In the event that a part is damaged or missing, L.Powell will be happy to provide you with replacement parts, at no charge, within 30 days of purchase, providing the parts are available in our warehouse and the item purchased is part of our current inventory. In order to receive spare parts, at no charge, you must provide proof of purchase within 30 days.

If you need assistance with assembly or replacement parts, please call L.Powell Customer Service, prior to returning the item to the store.

- Our office is open Monday – Friday 9am – 5pm, Eastern Standard Time.
- Our toll free customer service number is: 800 - 622 - 4456
- Or visit our web site [www.powellcompany.com](http://www.powellcompany.com) to order spare parts and for care instructions on your newly purchased furniture.

## **Nous sommes là pour vous aider!**

### **Avant de retourner le produit, veuillez communiquer avec nous.**

Nous faisons tout en notre pouvoir pour que vous receviez votre meuble en parfait état. Toutefois, si une pièce est endommagée ou manquante, L.Powell se fera un plaisir de vous envoyer gratuitement la pièce de rechange, dans les 30 jours suivant l'achat, à condition que nous ayons la pièce en stock et que le produit acheté fasse partie de notre inventaire courant. Afin de recevoir gratuitement la pièce de rechange, vous devez fournir une preuve d'achat dans un délai de 30 jours.

Si vous avez besoin d'une pièce de rechange ou d'aide pour l'assemblage, veuillez communiquer avec le Service à la clientèle de L.Powell avant de retourner le produit au magasin.

- Nos bureaux sont ouverts du lundi au vendredi, de 9 h à 17 h, heure normale de l'Est.
- Le numéro sans frais pour joindre notre Service à la clientèle est le 800 - 622 - 4456.
- Vous pouvez aussi visiter notre site Web à [www.powellcompany.com](http://www.powellcompany.com) pour commander des pièces de rechange et pour obtenir les instructions d'entretien de votre nouveau meuble.

## **¡Estamos aquí para ayudarle!**

### **Antes de regresar el producto, comuníquese con nosotros.**

Hacemos todo lo posible para que su mobiliario se le entregue en excelentes condiciones. En caso de que falte una pieza o esté dañada, L.Powell le enviará con gusto la pieza de repuesto sin ningún costo dentro de los 30 días posteriores a la compra, siempre y cuando tengamos en existencia las piezas en nuestros almacenes y que el artículo comprado forme parte de nuestro inventario actual. Para recibir piezas de repuesto, sin costo adicional, debe enviarnos el comprobante de compra dentro de los 30 días después de la compra.

Si necesita ayuda para ensamblar su producto o para obtener piezas de repuesto, llame al Servicio al Cliente de L.Powell antes de devolver el artículo a la tienda.

- Nuestras oficinas están abiertas de lunes a viernes de las 9.00 a las 17.00 horas, hora del Este.
- Número de Servicio al Cliente gratuito: 800 - 622 - 4456.
- Para pedir piezas de repuesto y consultar las instrucciones de cuidados de su mueble recién adquirido, visite nuestro sitio Web [www.powellcompany.com](http://www.powellcompany.com).







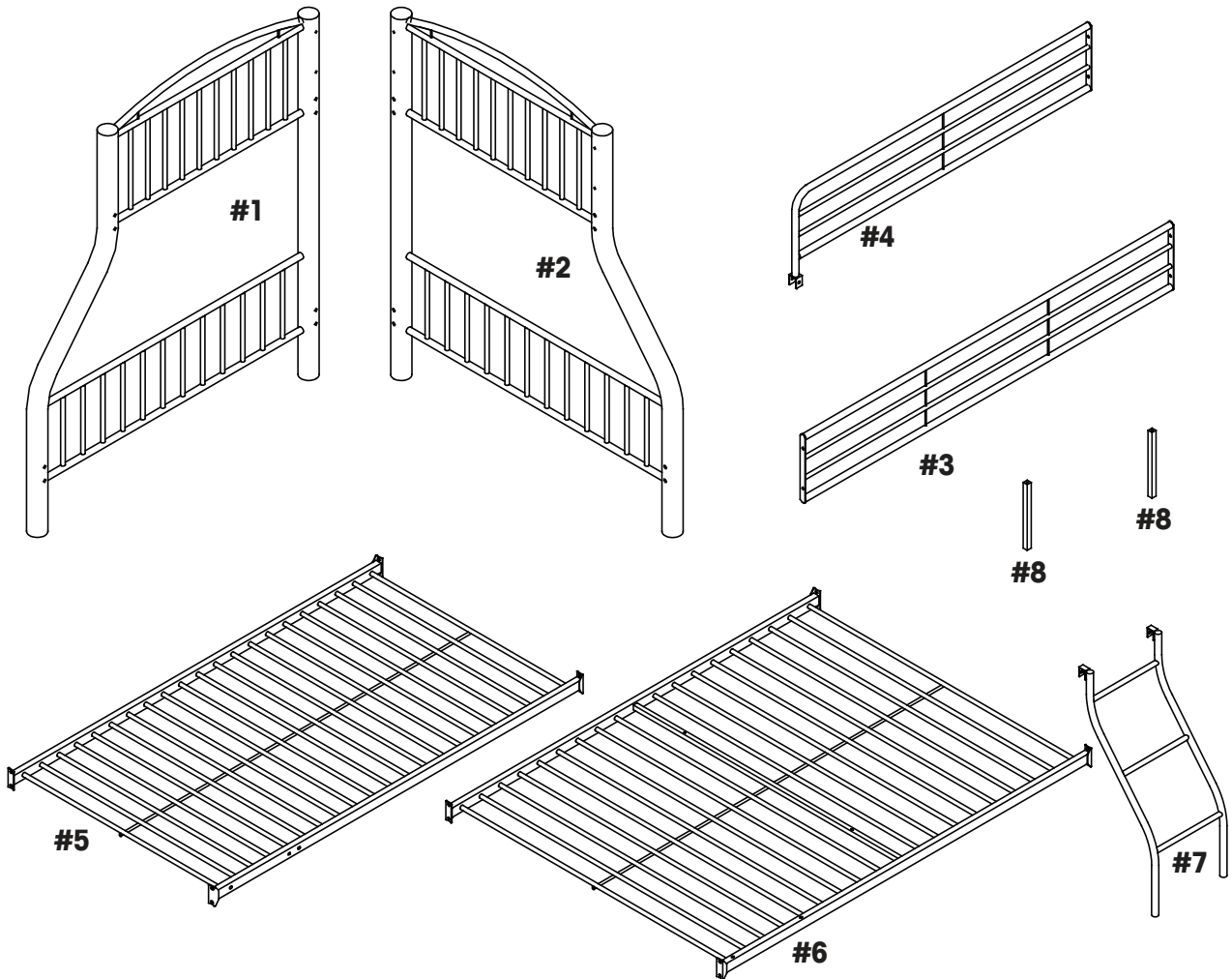

## PART LIST

#1	LEFT PANEL	01
#2	RIGHT PANEL	01
#3	BACK GUARDRAIL	01
#4	FRONT GUARDRAIL	01

#5	UPPER BED FRAME	01
#6	LOWER BED FRAME	01
#7	LADDER	01
#8	SUPPORT LEG	02

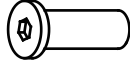

## HARDWARE LIST

<b>A</b>	<b>BOLT (Ø5/16"x2-1/2")</b>		<b>02</b>
<b>B</b>	<b>BOLT (Ø1/4"x1-3/4")</b>		<b>04</b>
<b>C</b>	<b>BOLT (Ø5/16"x3/4")</b>		<b>16</b>
<b>D</b>	<b>BOLT (Ø1/4"x3/4")</b>		<b>07</b>
<b>E</b>	<b>FLAT WASHER (Ø3/4")</b>		<b>18</b>
<b>F</b>	<b>FLAT WASHER (Ø5/8")</b>		<b>11</b>
<b>G</b>	<b>SPRING WASHER (Ø1/2")</b>		<b>18</b>
<b>H</b>	<b>SPRING WASHER (Ø7/16")</b>		<b>11</b>
<b>I</b>	<b>NUT</b>		<b>01</b>

## TOOLS REQUIRED



<b>ALLEN KEY</b>		<b>SUPPLIED</b>
<b>ALLEN KEY</b>		<b>SUPPLIED</b>

### IMPORTANT:

1. Do not tighten bolts completely until all bolts are completely lined up and inserted into holes / nuts.
2. Do not over tighten screws and bolts to avoid stripping.
3. Please use hand tools to assemble this product. Do not use power tools.

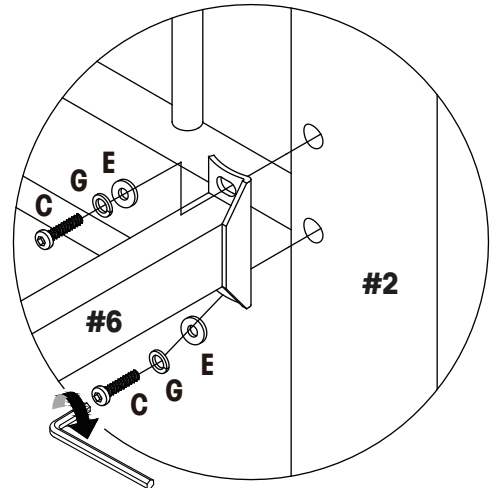
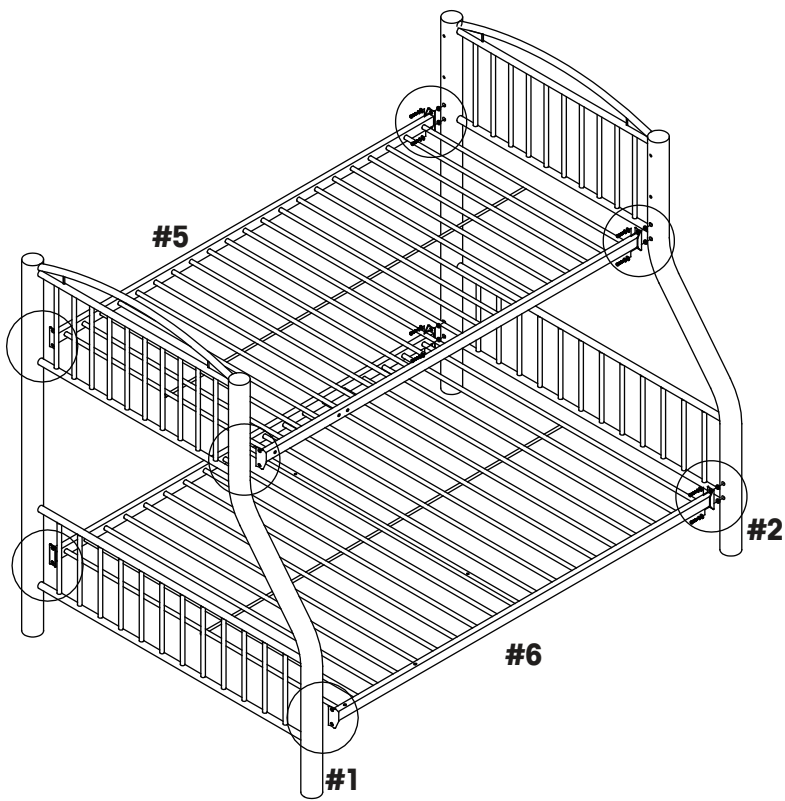

1.



C		16
G		16
E		16

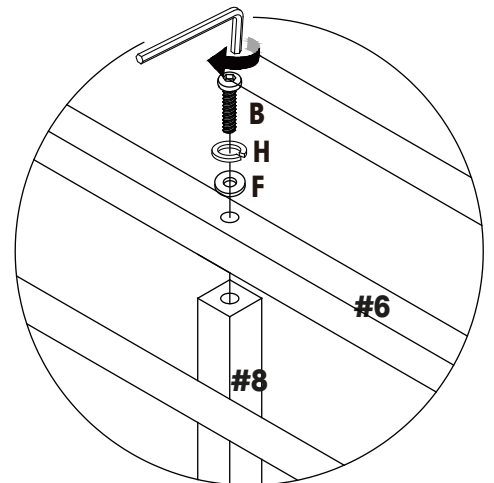
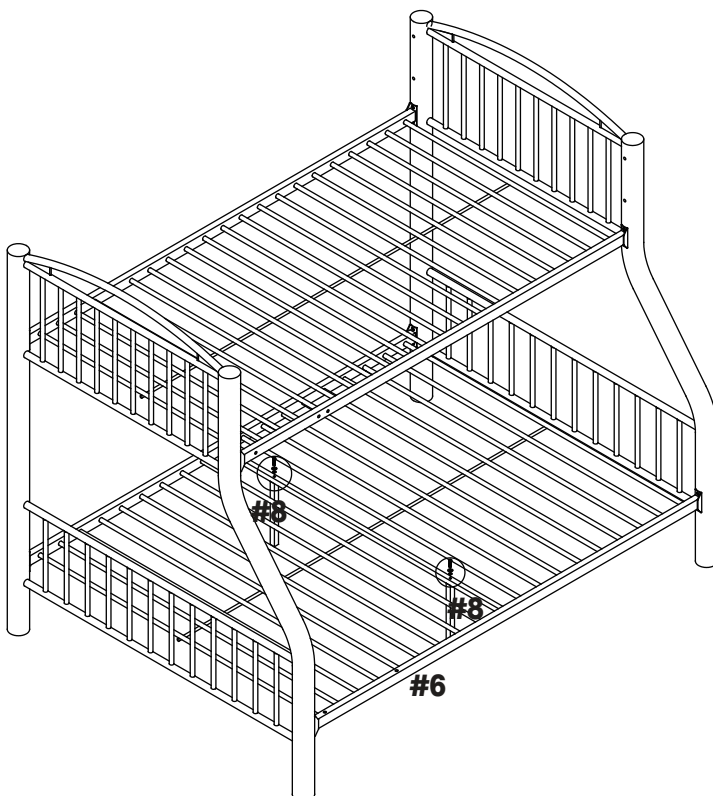





2.

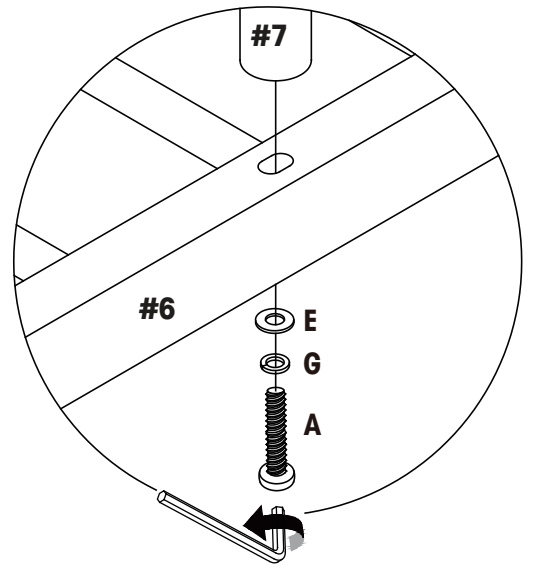
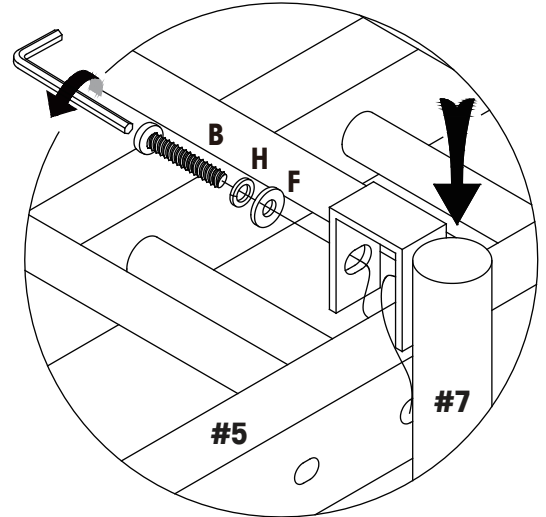
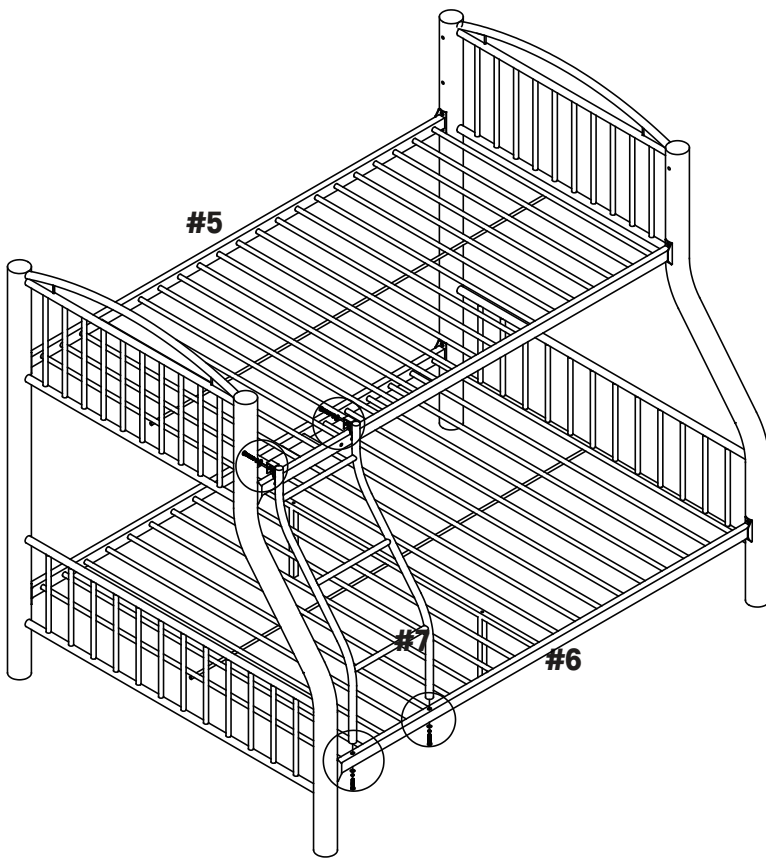

B		02
H		02
F		02





3.

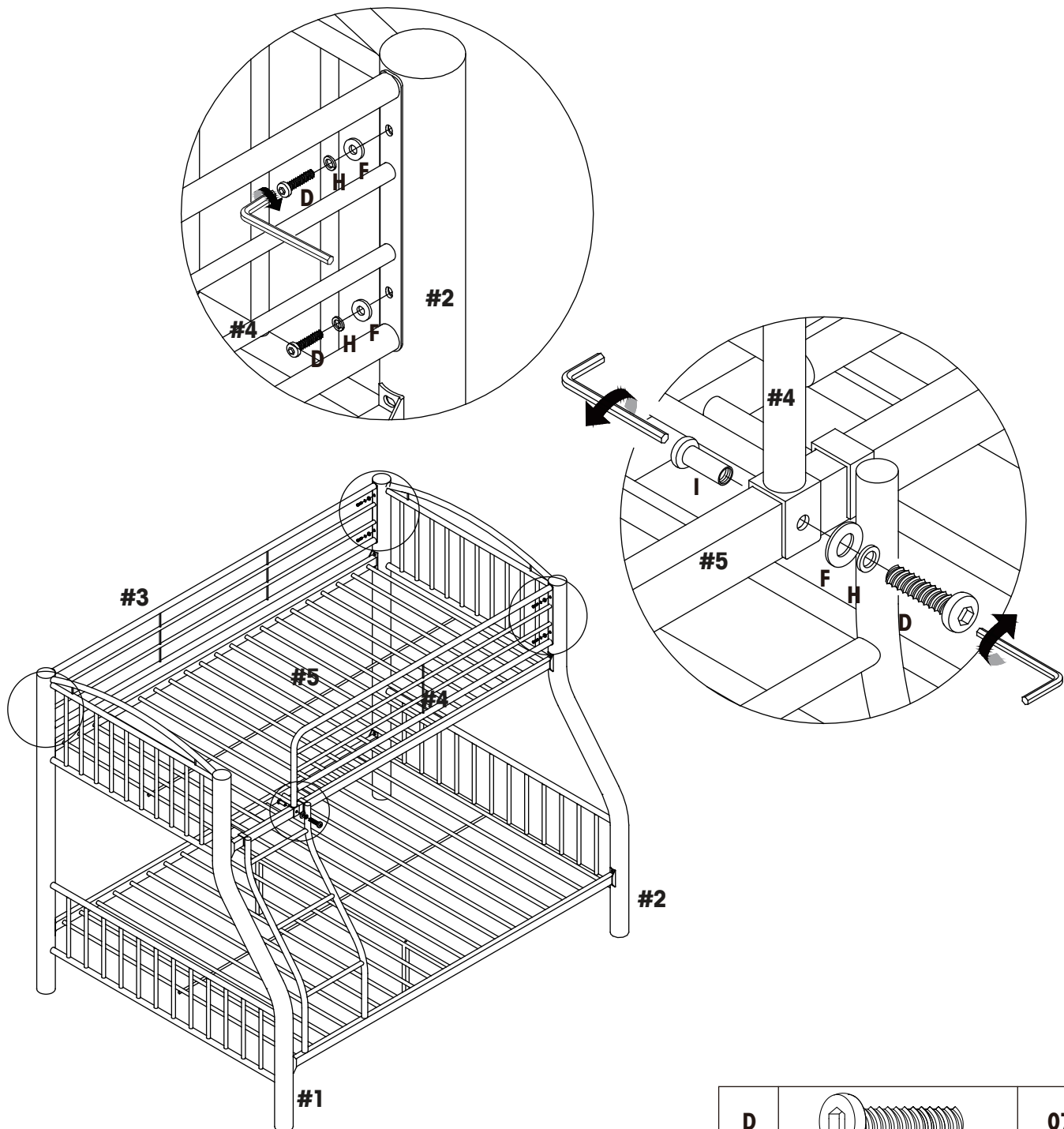

A		02
G		02
E		02
B		02
H		02
F		02

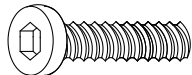
5.



D		07
H		07
F		07
I		01



- Never allow a child under 6 years old on the upper bunk.
- Always use the recommended size mattress or mattress support, or both, to help prevent the likelihood of entrapment or falls.
- Use only a mattress which is 74"- 75" long and 37-1/2- 38-1/2" wide on the upper bunk, 74"- 75" long and 53-1/2- 54-1/2" wide on the lower bunk.
- Ensure thickness of mattress does not exceed 8" and surface of mattress is at least 5" below upper edge of guardrails.
- Always use guardrails on both long sides of the upper bunk.
- If bunk bed will be placed next to a wall, the guardrail that runs the full length of the bed should be placed against the wall to prevent entrapment between the bed and the wall.
- Prohibit horseplay on or under bed(s) and prohibit jumping on the bed.
- Prohibit more than one person on upper bunk.
- Use ladder for entering and leaving upper bunk.
- Maximum total weight is not to exceed 300 lbs. on the upper bunk.
- Periodically check and ensure that the guardrail, ladder, and other components are in their proper position, free from damage, and that all connectors are tight.
- Do not use substitute parts. Replacement parts, including additional guardrails, may be obtained from our customer service department.
- Use of water or sleep flotation mattresses is prohibited.
- Use of a night light may provide added safety precaution for a child using the upper bunk.
- Follow the information on the warnings appearing on the upper bunk end structure and on the carton
- Keep these instructions for future reference.

**STRANGULATION HAZARD** Never attach or hang items to any part of the bunk bed that are not designed for use with the bed; for example, but not limited to, hooks, belts and jump ropes.

**DO NOT REMOVE THIS LABEL, KEEP THESE INSTRUCTIONS FOR FUTURE REFERENCE.**

