

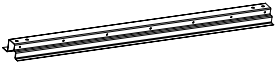

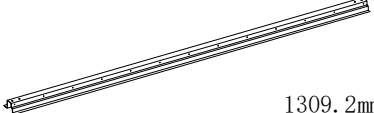







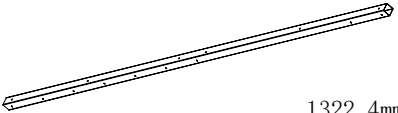
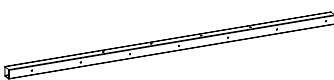
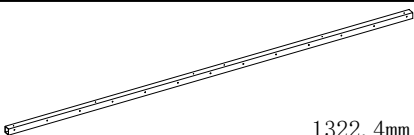
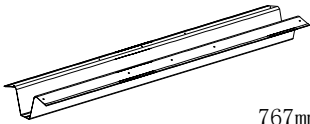



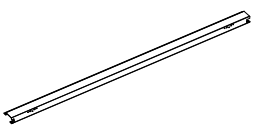
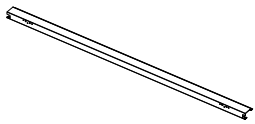
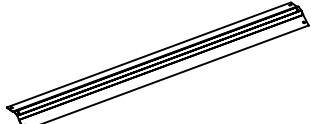
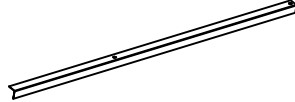
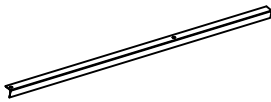





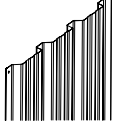

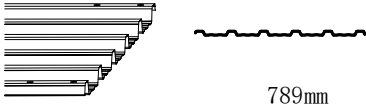
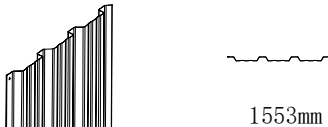
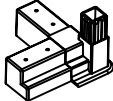

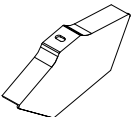
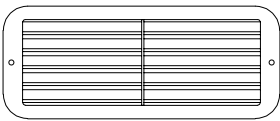

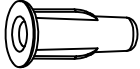

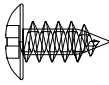
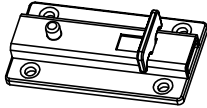

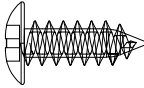

NO.	PART.	Qty.
1	 1309.2mm	1
2	 667.2mm	1
3	 1309.2mm	1
5	 1510mm	4
6	 1322.4mm	1
7	 680.4mm	2
8	 1322.4mm	1
9	 767mm	1
11L	 230mm	2
11R	 230mm	2
15	 835.4mm	4
16	 1555mm	1

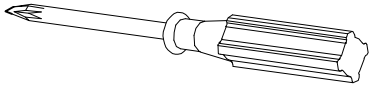
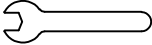
NO.	PART.	Qty.
17L	 1560mm	1
17R	 1560mm	1
18	 876mm	1
19L	 876mm	1
19R	 876mm	1
20	 797mm	4
21	 491mm	4
21L		2
21R		2
22	 1555mm	1
23	 1555mm	1
W3	 1560mm	8

NO.	PART.	Qty.
W7	 1560mm	4
W12	 789mm	2
W15	 789mm	2
M1	 1553mm	2
C		4
F		4
F4		4
F5		2
F6		4
F7		46
F8		30
F9		2



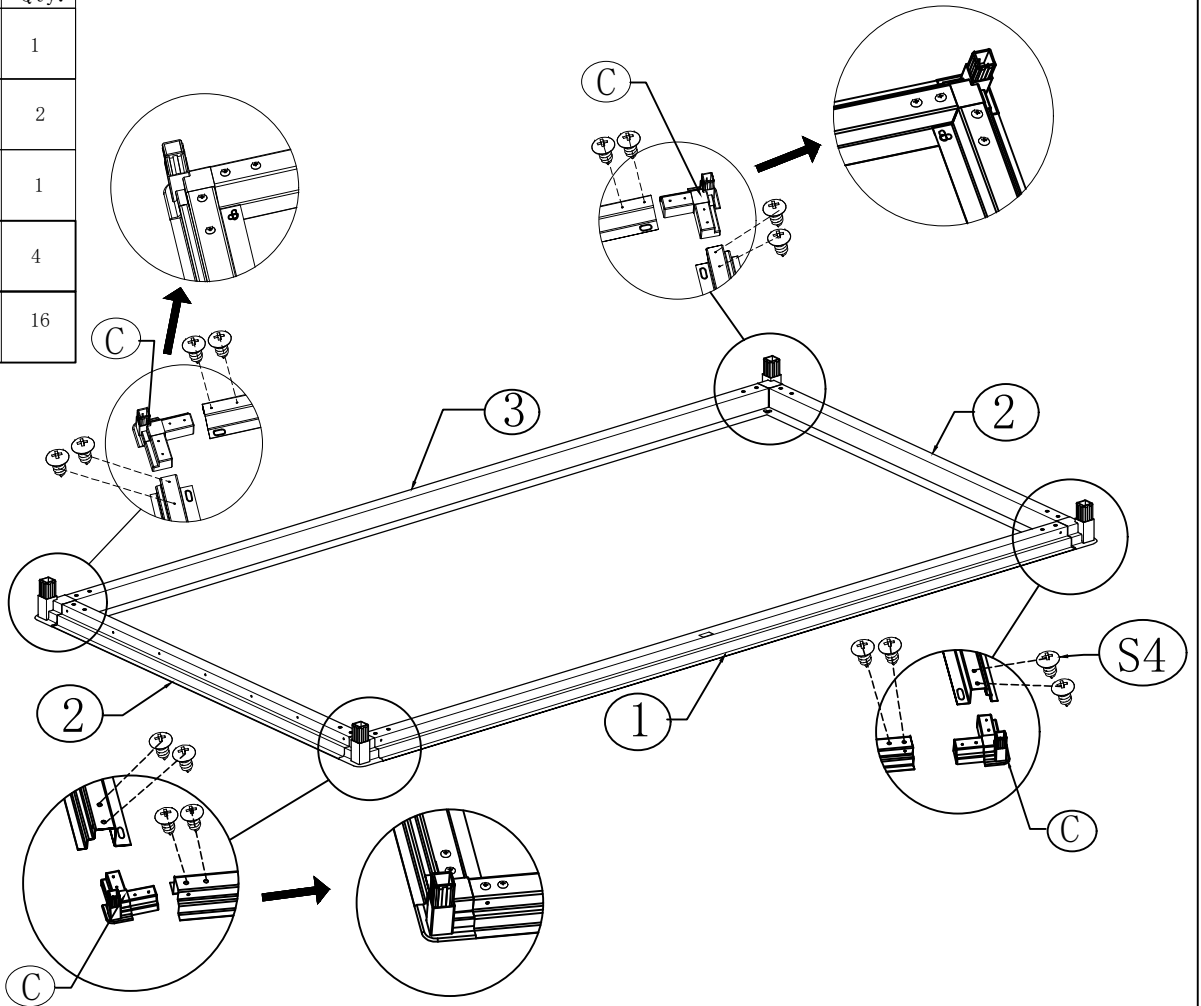

NO.	PART.	Qty.
S4		170
S5		2
S6		51
S6A		6
S7		51
S8		4
S9		4
S12		1
S15		1
S17		2

NO.	PART.	Qty.
1	 1309, 2mm	1
2	 667, 2mm	2
3	 1309, 2mm	1
C		4
S4		16

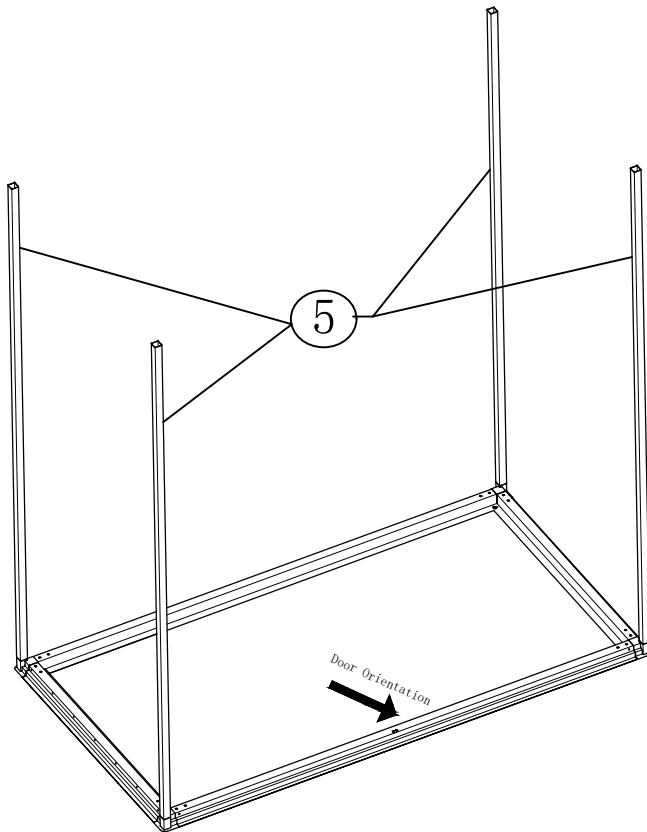





NO.	PART.	Qty.
5	 1510mm	4

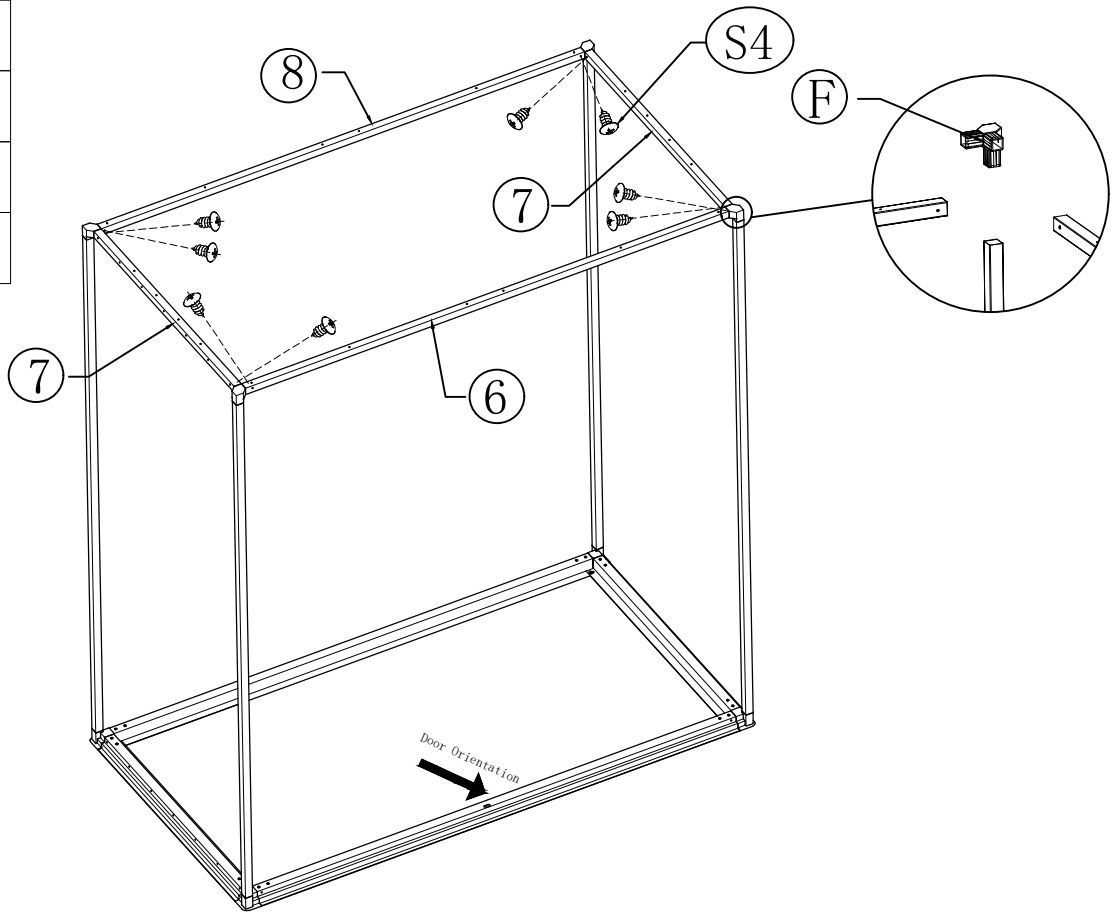





NO.	PART.	Qty.
6	 1322.4mm	1
7	 680.4mm	2
8	 1322.4mm	1
F		4
S4		8

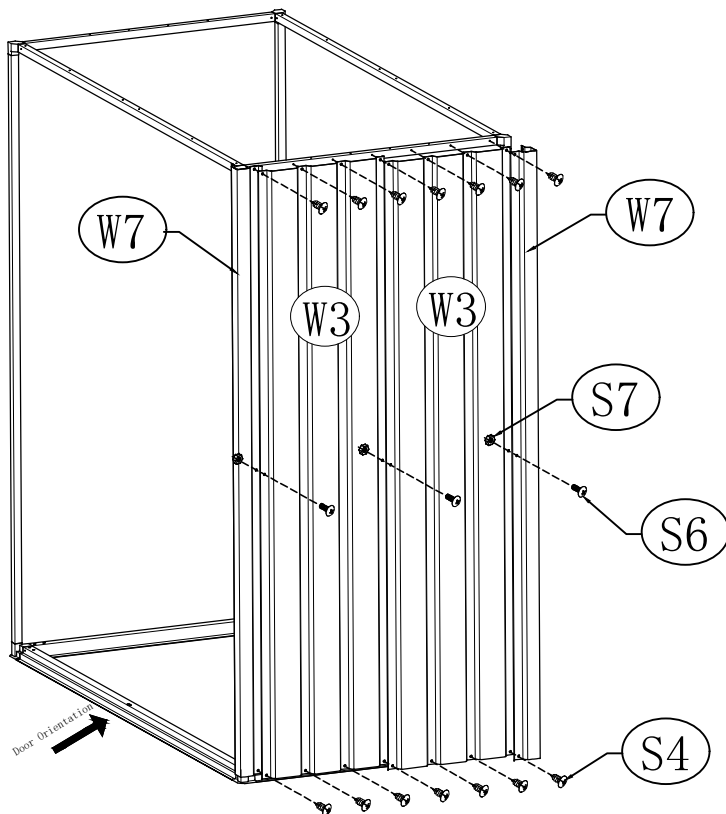

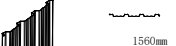



NO.	PART.	Qty.
W3	 1560mm	2
W7	 1560mm	2
S4		14
S6		3
S7		3

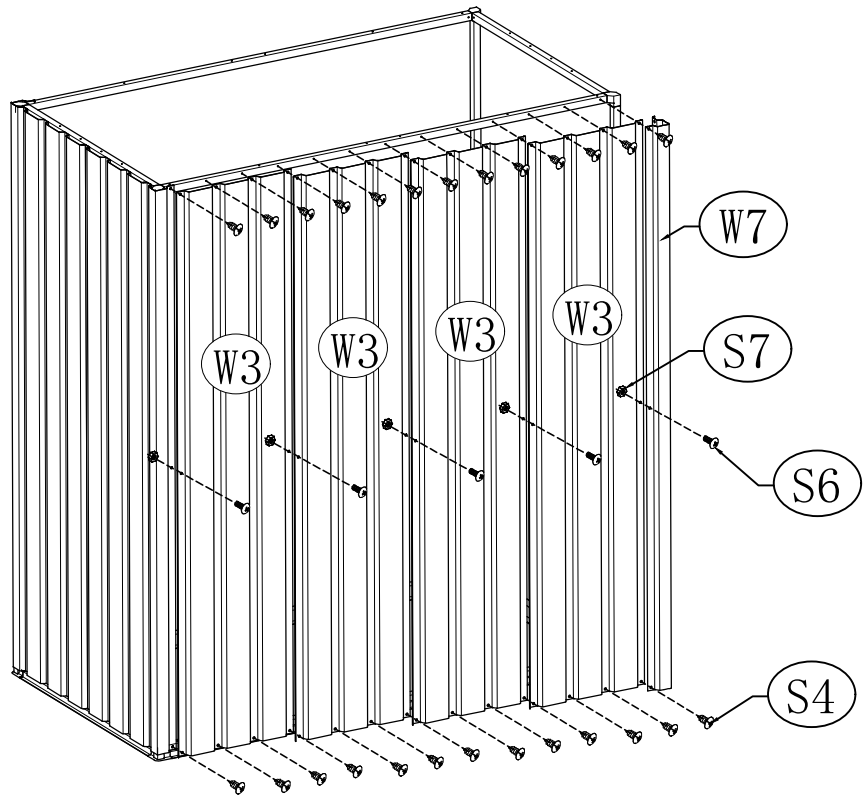

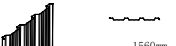



NO.	PART.	Qty.
W3	 1560mm	4
W7	 1560mm	1
S4		26
S6		5
S7		5

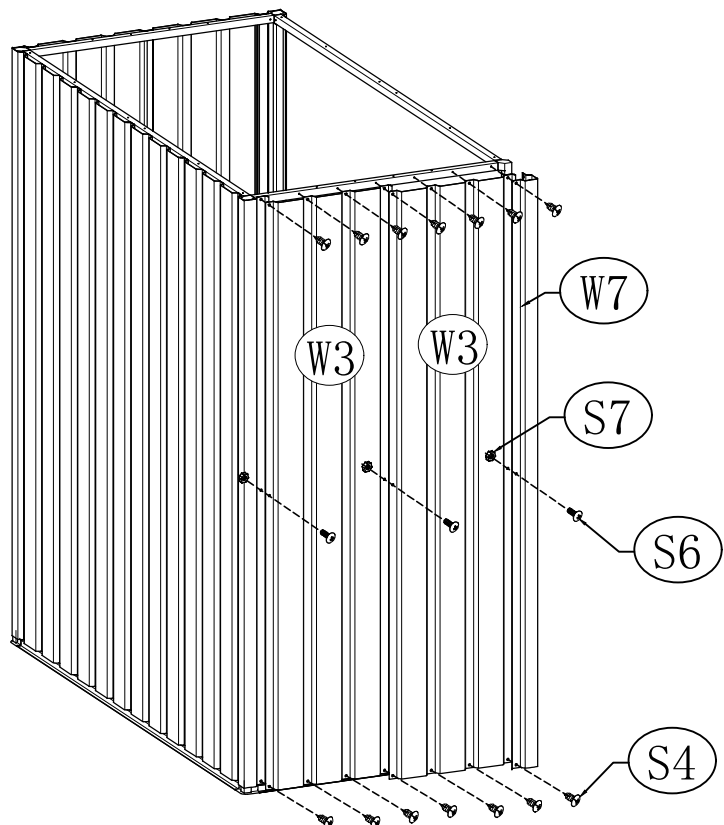

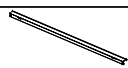



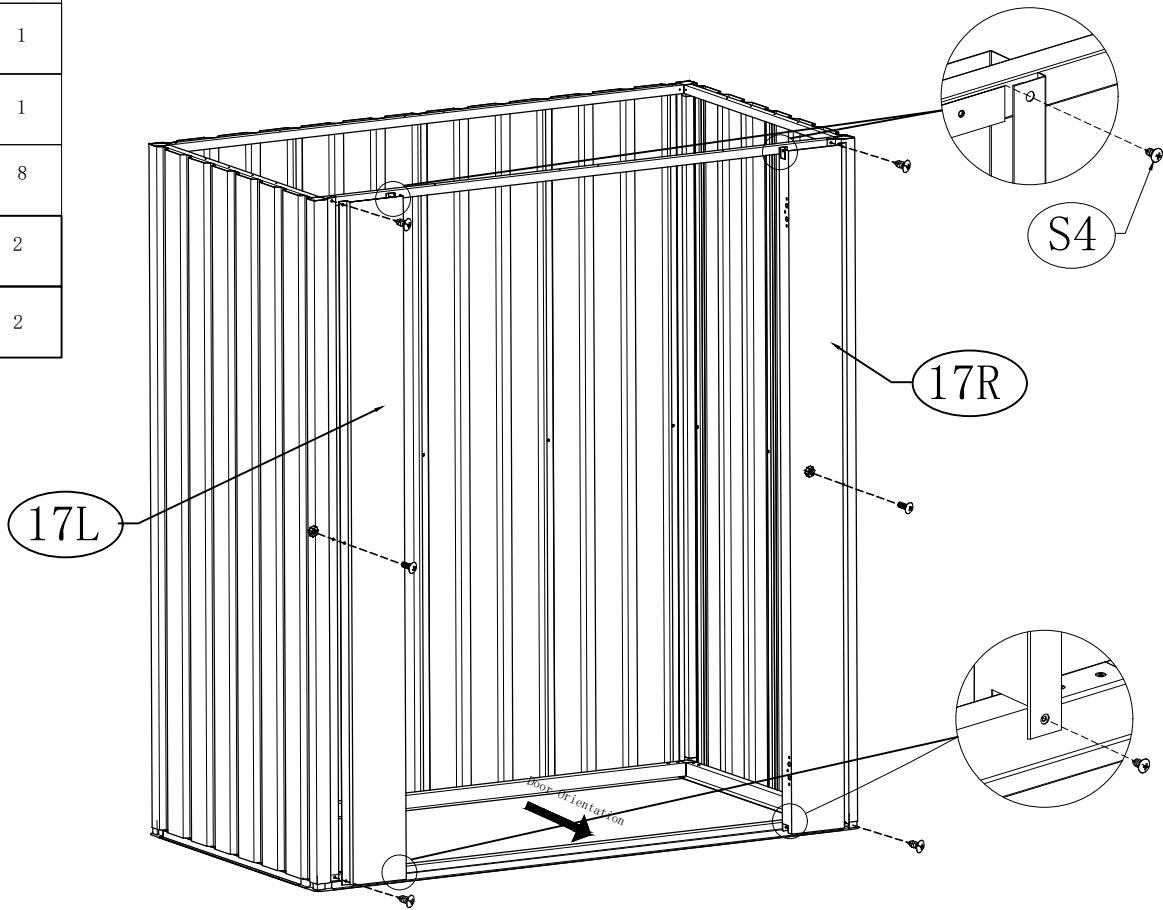

NO.	PART.	Qty.
W3	 1560mm	2
W7	 1560mm	1
S4		14
S6		3
S7		3





NO.	PART.	Qty.
17L	 1560mm 1	1
17R	 1560mm 1	1
S4	 8	8
S6	 2	2
S7	 2	2



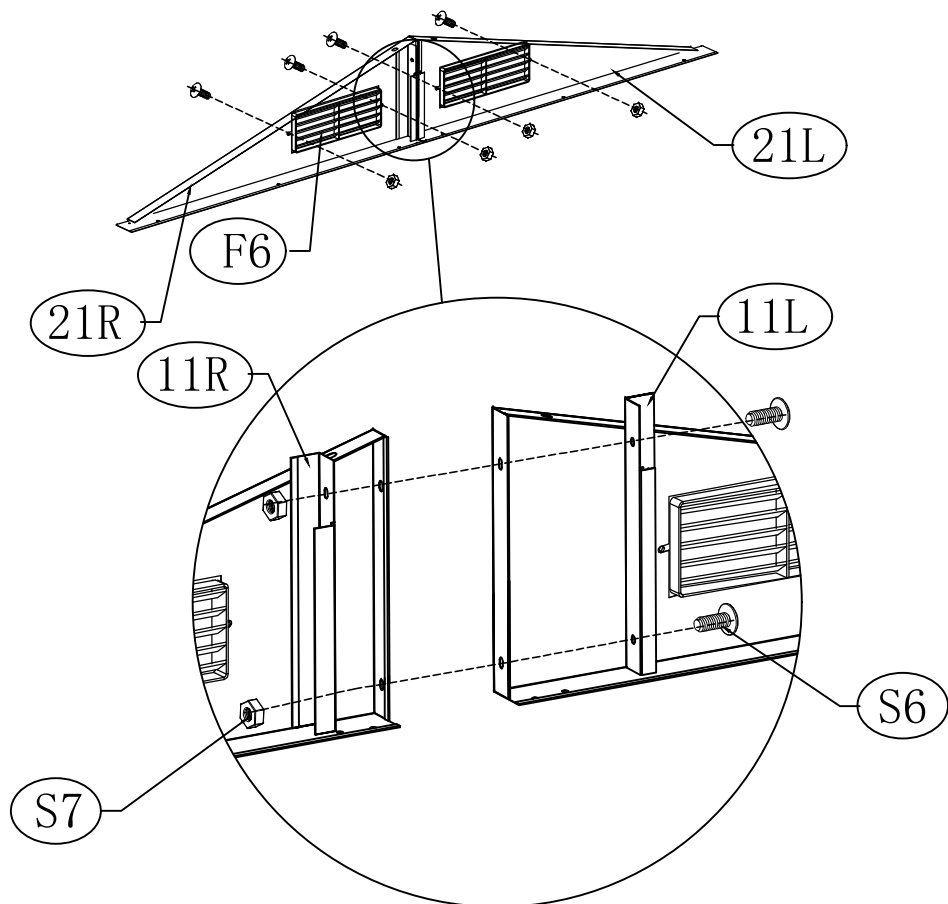

NO.	PART.	Qty.
11L	 230mm 2	2
11R	 230mm 2	2
21L	 2	2
21R	 2	2
S6	 12	12
S7	 12	12
F6	 4	4

X2



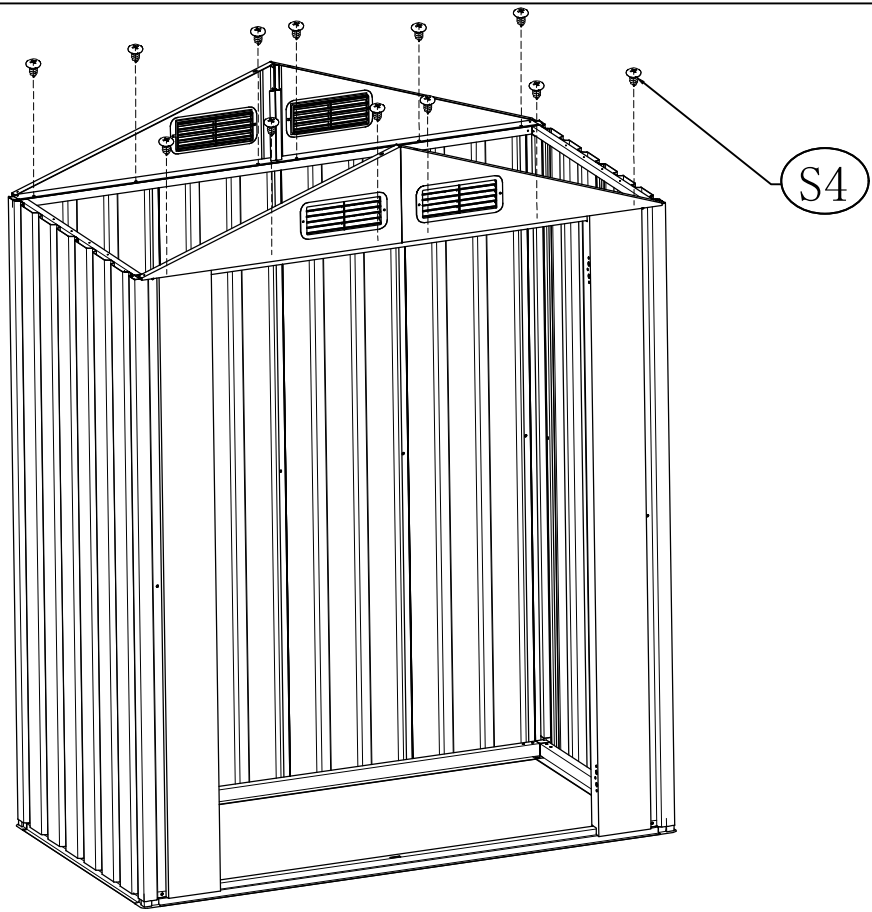



NO.	PART.	Qty.
S4		12

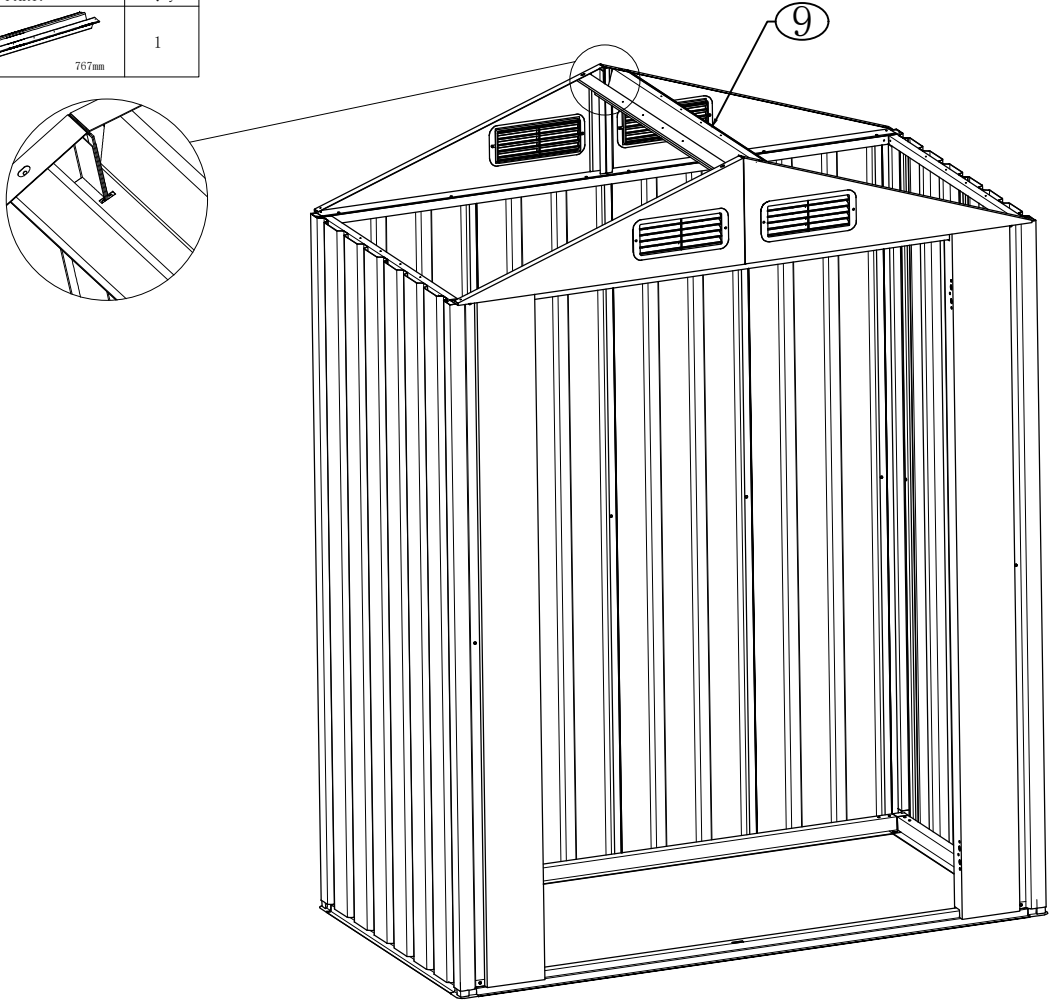



NO.	PART.	Qty.
9	 767mm	1



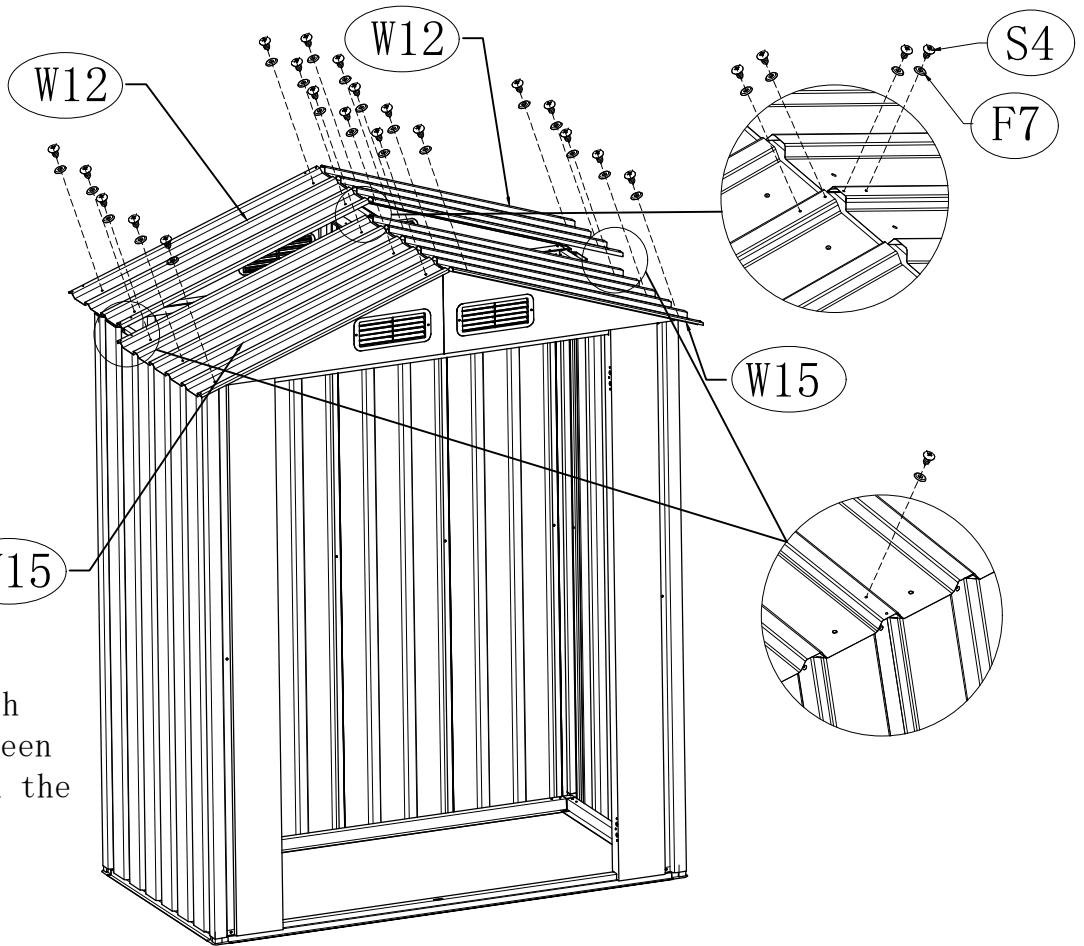



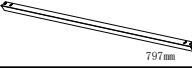

NO.	PART.	Qty.
W15	 789mm	2
W12	 789mm	2
S4		26
F7		26

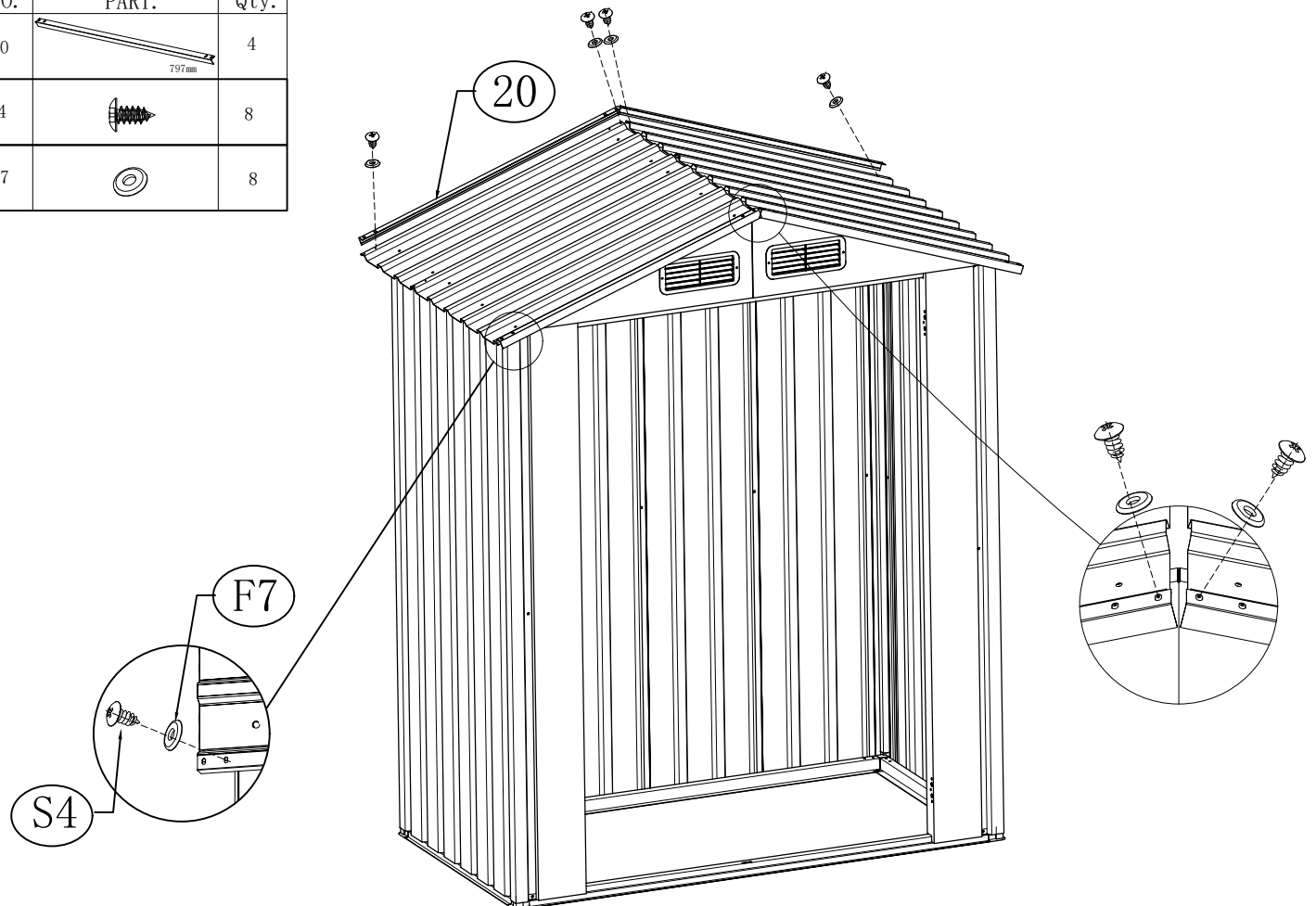



Place the side with small distance between holes and edges on the top.

NO.	PART.	Qty.
20	 797mm	4
S4		8
F7		8



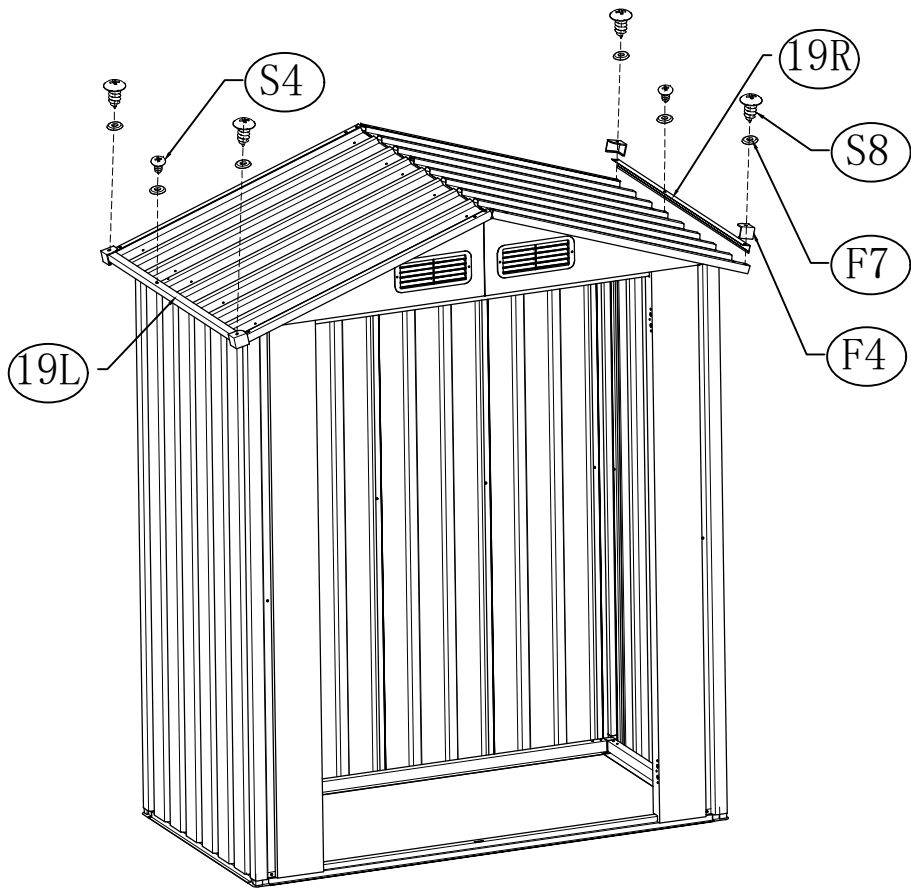



NO.	PART.	Qty.
19L	 876mm	1
19R	 876mm	1
F4		4
S4		2
S8		4
F7		6

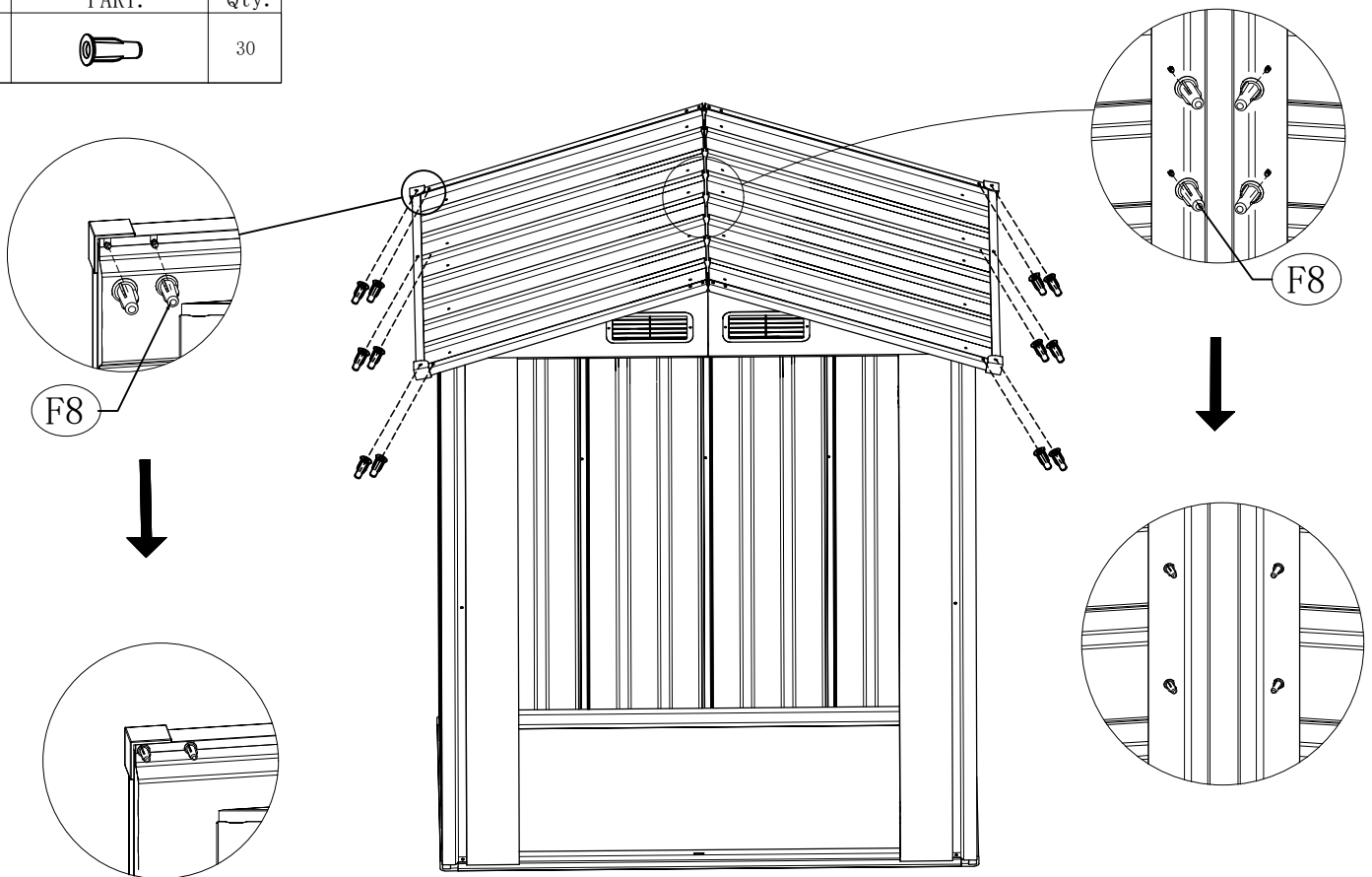





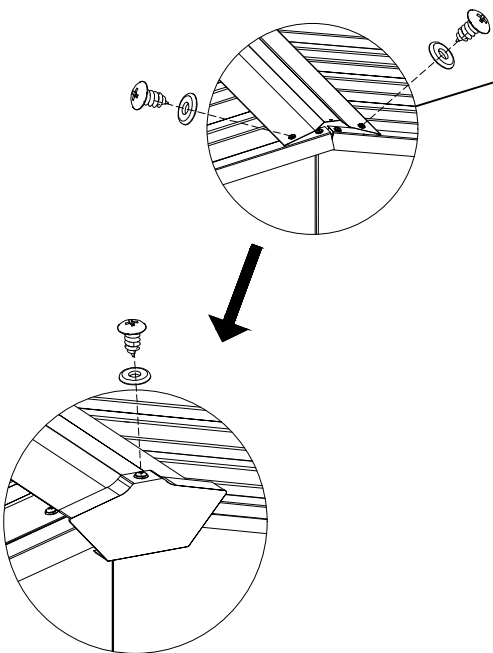
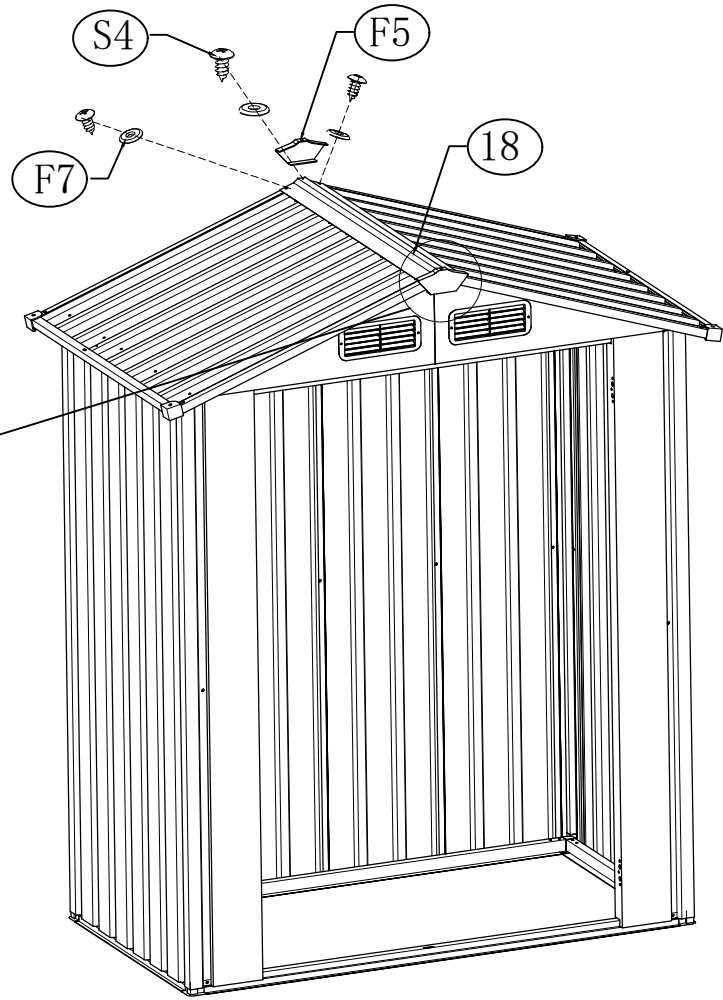

NO.	PART.	Qty.
F8		30

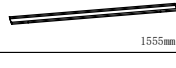
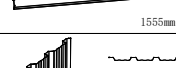



NO.	PART.	Qty.
18	 876mm	1
F5		2
S4		6
F7		6



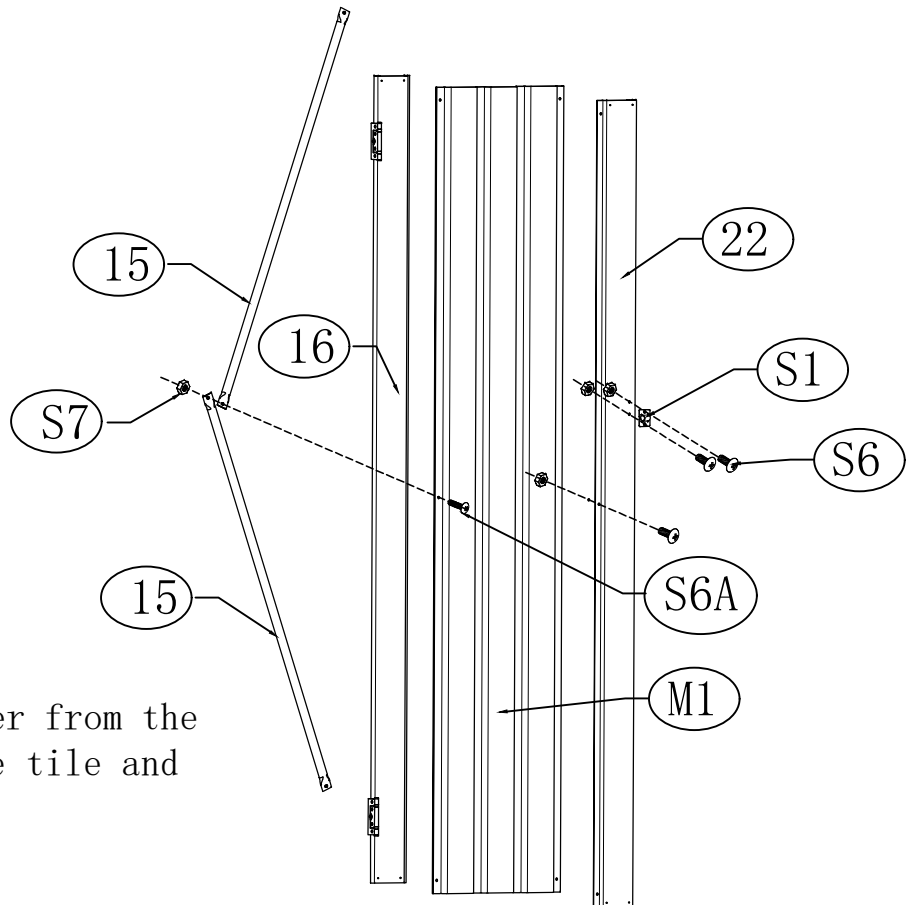





NO.	PART.	Qty.
15	 835.4mm	2
16	 1555mm	1
22	 1555mm	1
M1	 1553mm	1
S6		3
S6A		1
S7		4
S1		1

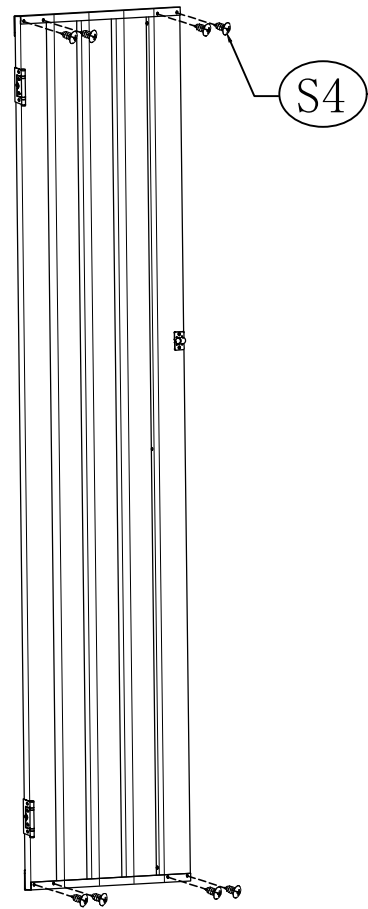
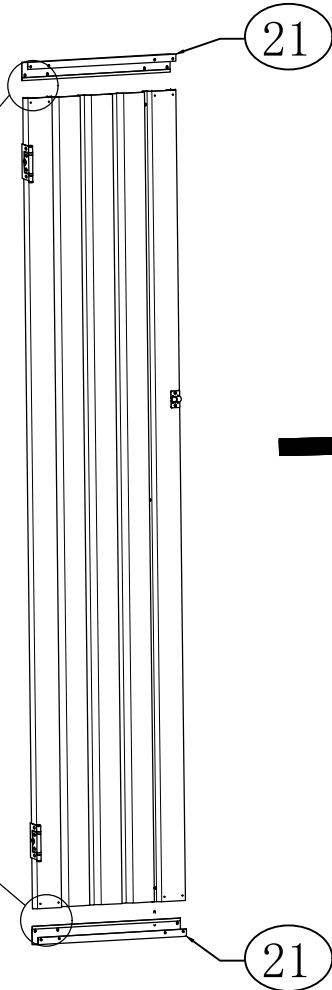
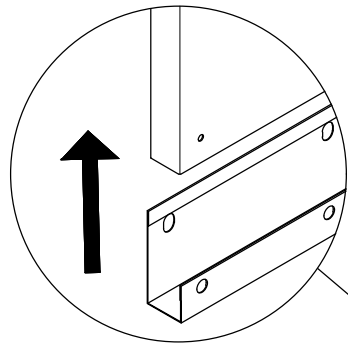
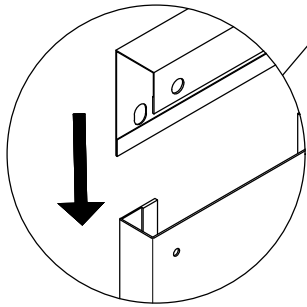









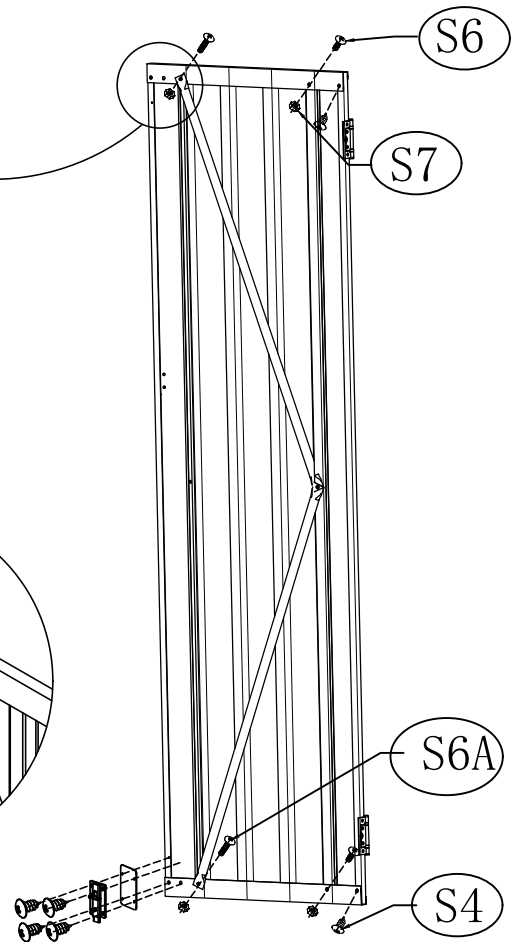
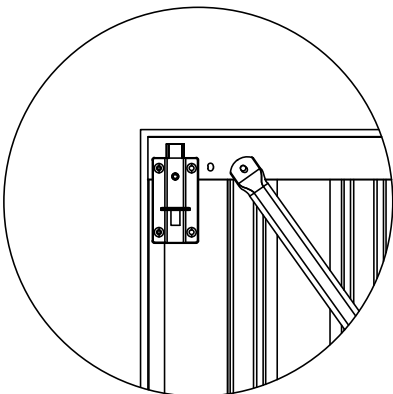
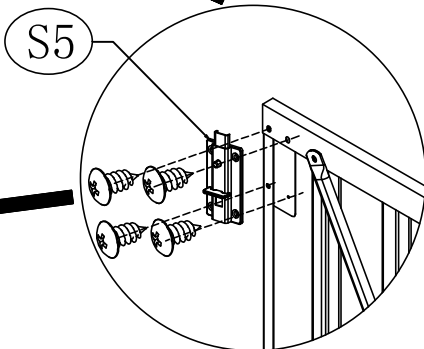
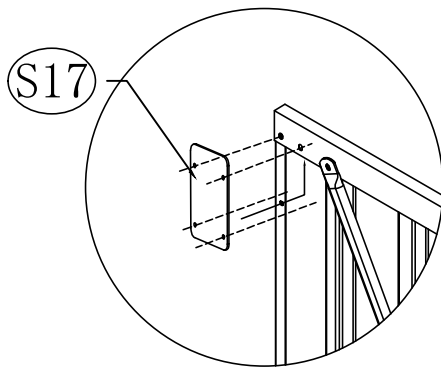

Put 16 on the side farther from the hole in the center of the tile and 22 on the side nearer.

NO.	PART.	Qty.
21	 491mm 2	2
S4		8





NO.	PART.	Qty.
S4		10
S5		2
S6		2
S6A		2
S7		4
S17		2



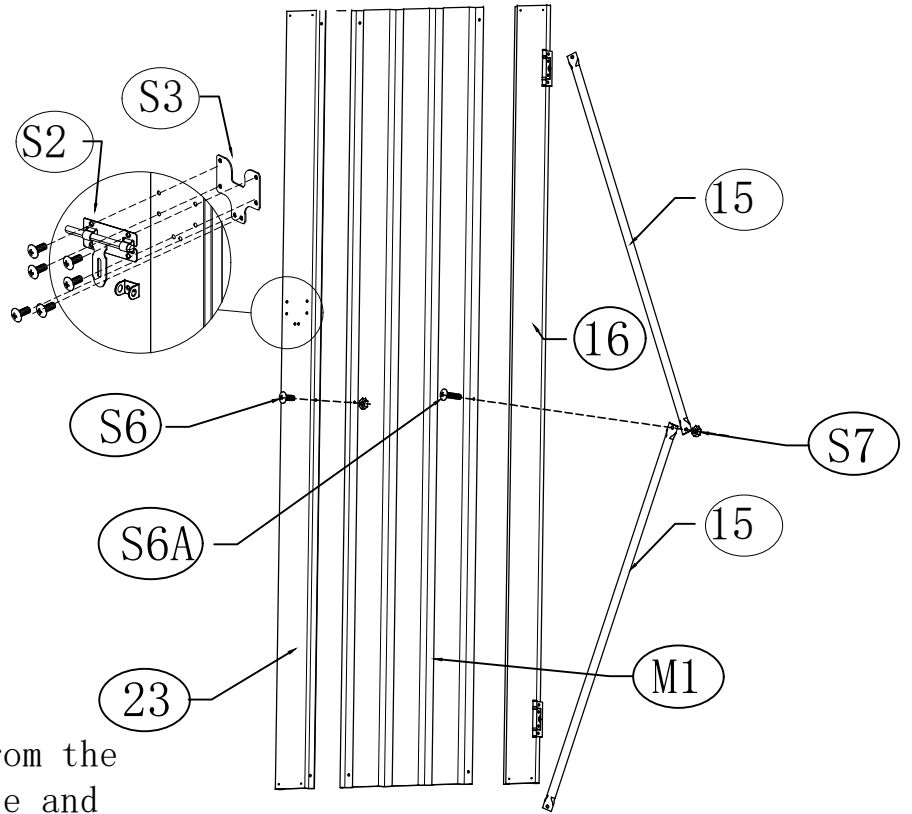



NO.	PART.	Qty.
15	 835.4mm	2
16	 1555mm	1
23	 1555mm	1
M1	 1553mm	1
S6		7
S6A		1
S7		2
S2		1
S3		1



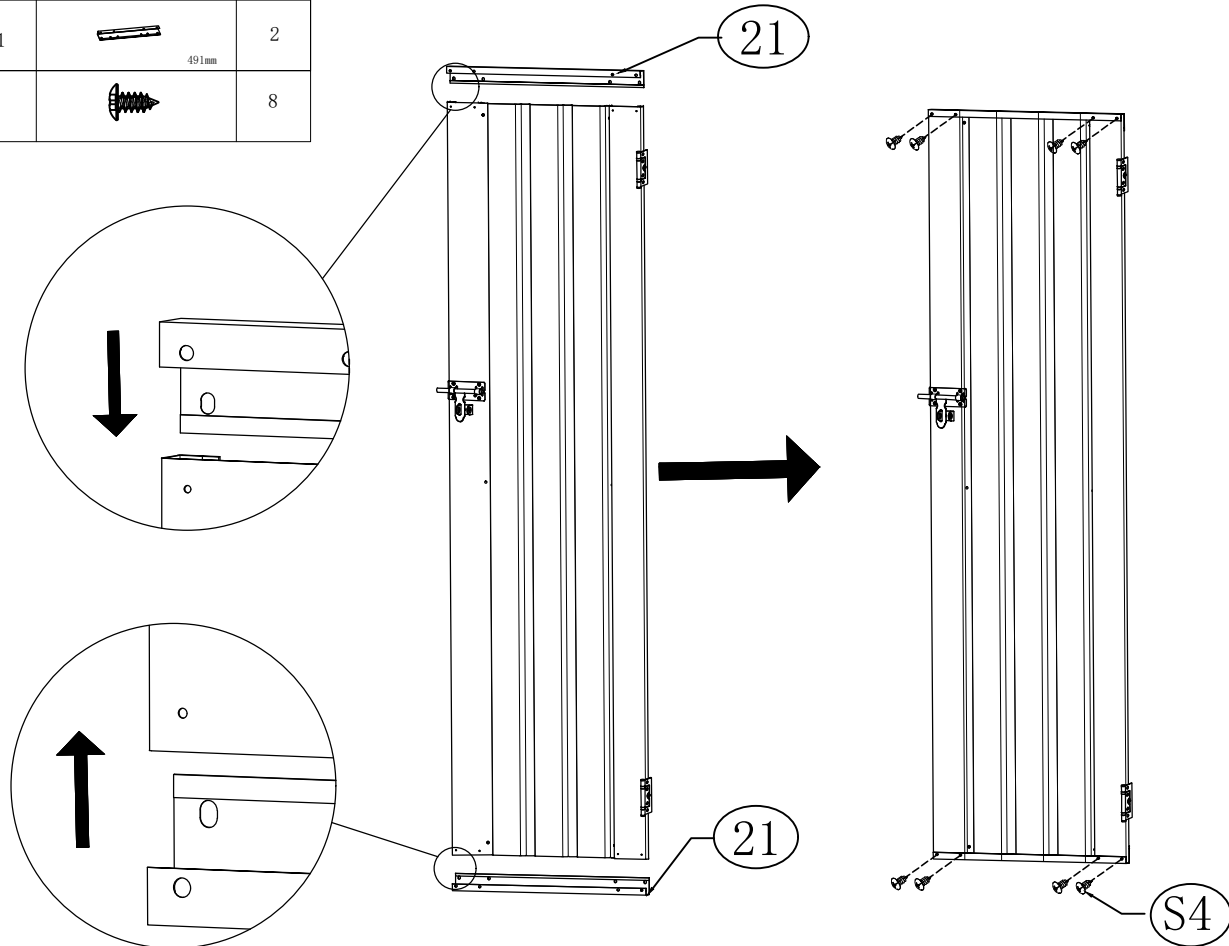

Put 16 on the side farther from the hole in the center of the tile and 23 on the side nearer.

NO.	PART.	Qty.
21	 491mm	2
S4		8

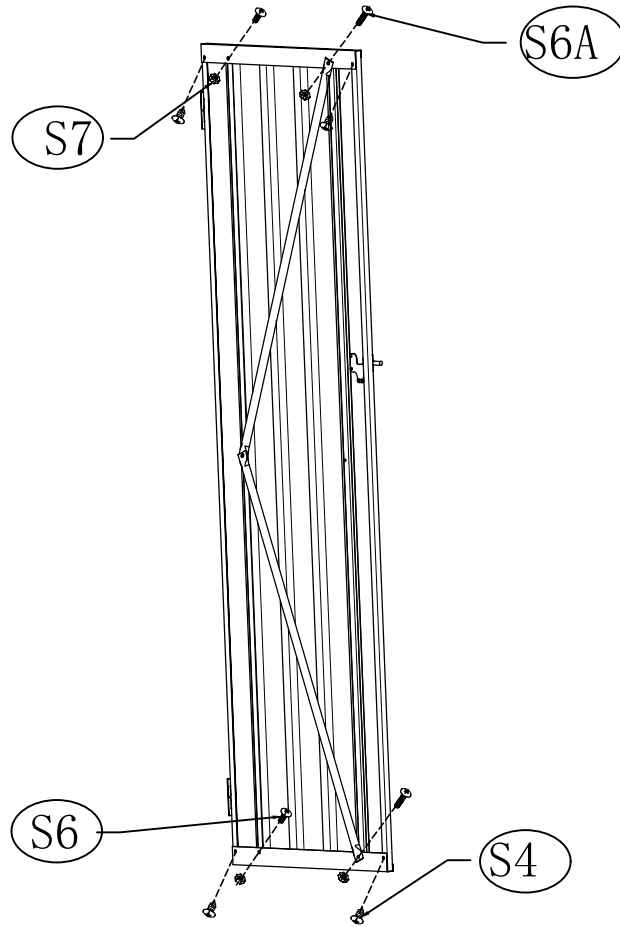

NO.	PART.	Qty.
S4		4
S6		2
S6A		2
S7		4



NO.	PART.	Qty.
S6		12
S7		12

