

Features and Specifications:

- Bar/prep sink.
- Made of 80% quartz and the finest acrylic resins.
- Designed for top mount (drop-in) installation in all types of countertop materials.
- Outside dimensions: 18" x 16" x 7-1/2".
- Waste opening: 3-1/2".
- Sink bowl surface has a matte finish.
- Supplied with mounting clips and cutout template.
- Basket strainer shown not included with sink.
- Basket strainers in stainless steel or matching colors available as optional accessories.
- Sinks colors available: Black, Bisque, White, Concrete, Brown, Grey

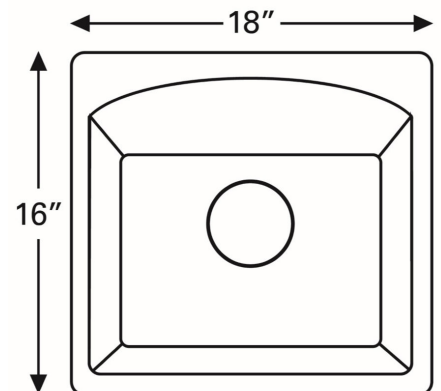

TOP ELEVATION



FRONT ELEVATION

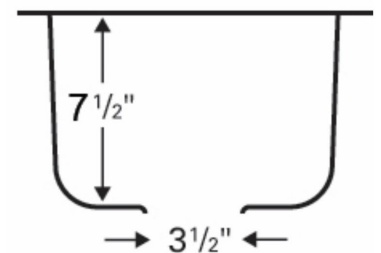

ALL DIMENSIONS ACCURATE TO 1/4"