

ASSEMBLY INSTRUCTIONS

HOUSE BED WITH TRUNDLE

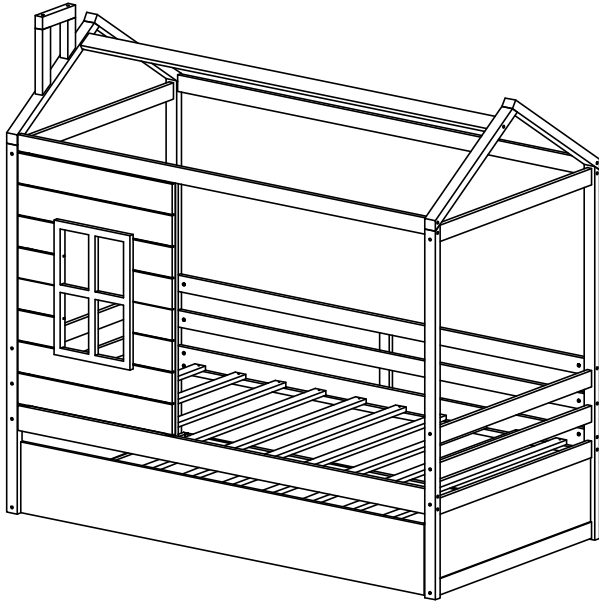





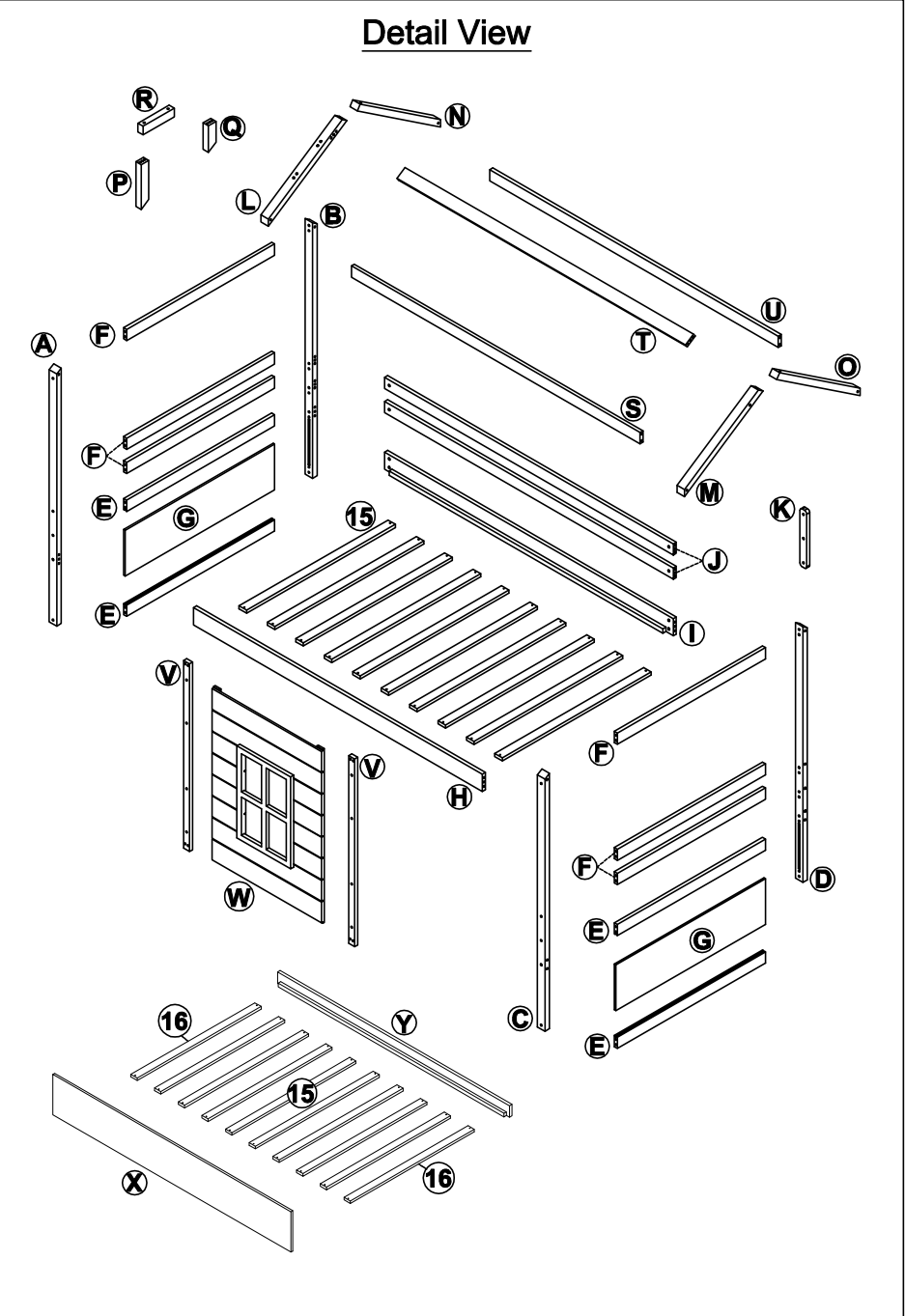







If you have any questions, please feel free to contact us.
Email: service@qualfurn.net















WF281232/WF281233



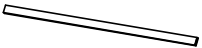

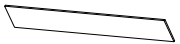





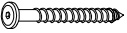

Part List : WF281232

E  HB-FB horizontal (lower) - 4pcs	F  HB-FB horizontal (upper) - 6pcs	G  HB-FB panel - 2pcs
L  Cap of bed (front left) - 1pc	M  Cap of bed (front right) - 1pc	N  Cap of bed (back left) - 1pc
O  Cap of bed (back right) - 1pc	P  Long bar of funnel - 1pc	Q  Short bar of funnel - 1pc
R  Top bar of funnel - 1pc	W  Front frame - 1pc	15  Slat - 10pcs

Part List : WF281233

A  Front left leg - 1pc	B  Back left leg - 1pc	C  Front right leg - 1pc
D  Back right leg - 1pc	H  Front side rail - 1pc	I  Back side rail - 1pc
J  Back horizontal - 2pcs	K  Back vertical - 1pc	S  Horizontal (top front) - 1pc
T  Horizontal (top middle) - 1pc	U  Horizontal (top back) - 1pc	V  Front vertical - 2pcs
X  Drawer front - 1pc	Y  Drawer back - 1pc	15  Slat - 8pcs
16  Slat - 2pcs		

Hardware List: WF281233

1  Ø10*30mm Wood dowel (46pcs)	2  Ø6*85mm Hex-Head screw (24pcs)	3  Ø1/4**100mm Hex-Head bolt (12pcs)
4  Ø1/4**15 Horizontal-Hole bolt (14pcs)	5  Ø1/4**85mm Hex-Head bolt (2pcs)	6  Ø6*30mm Hex-Head screw (19pcs)
7  Ø6*70mm Hex-Head screw (2pcs)	8  Ø6*80mm Hex-Head screw (8pcs)	9  #3*15mm Screw (8pcs)
10  #4*30mm Screw (40pcs)	11  Wheel (4pcs)	12  K4mm Allen key (1pc)

ASSEMBLY TOOLS REQUIRED (NOT INCLUDED)



PLEASE BE CAREFUL DO NOT DAMAGE THE HOLE POSITION WHEN YOU USE POWER TOOLS !

STEP 1:

Following below illustration Assembly FRAME #1.
Using hardware #1 & #5 connect R Top bar of funnel with P and Q Long-short bar of funnel to complete FRAME #1.

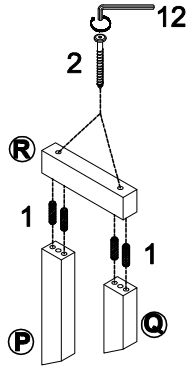

1	
4PCS	
2	
2PCS	

NOTE: In this step, DO NOT tighten any bolt until you connect all part together

STEP 2:

Following below illustration Assembly FRAME #2.
Using hardware #1 & #5 connect L Cap of bed (front left) with P and Q Long-short bar of funnel to complete FRAME #2.

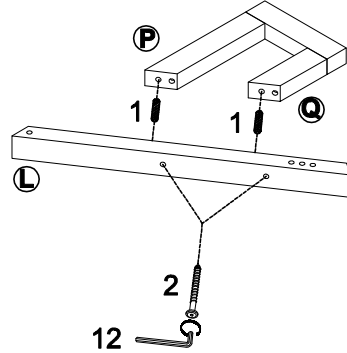

1	
2PCS	
2	
2PCS	

NOTE: In this step, DO NOT tighten any bolt until you connect all part together

STEP 3: Following below illustration Assembly FRAME #3.

Using hardware #1 & #7 connect N and O Cap of bed (back left-right) with L and M Cap of bed (front left-right) to complete FRAME #3L/R.

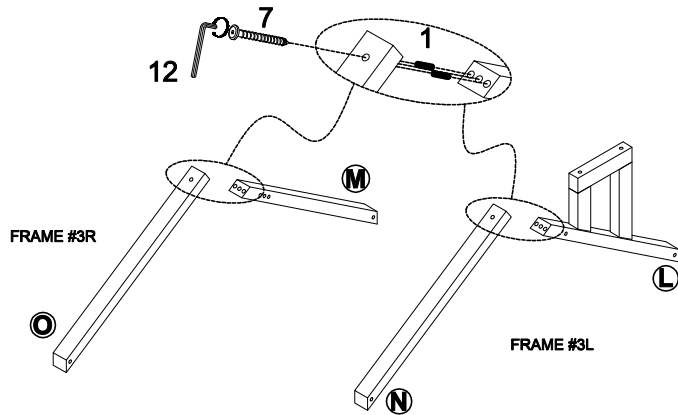

1	
4PCS	
7	
2PCS	

NOTE: In this step, DO NOT tighten any bolt until you connect all part together

5

STEP 4: Following below illustration Assembly FRAME #4.

Using hardware #1, #3 & #4 connect FRAME #3L (L and M Cap of bed (front left-right)) with T Horizontal (top middle) to complete FRAME #4.

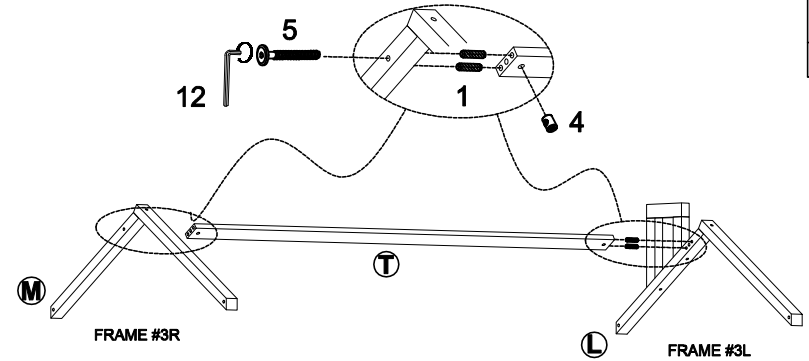

1		5	
4PCS		2PCS	
		4	
		2PCS	

NOTE: In this step, DO NOT tighten any bolt until you connect all part together

STEP 5: Following below illustration Assembly FRAME #5.

Using hardware #8 connect L, M, N and O Cap of bed with S and U Horizontal (top front-back) to complete FRAME #5.

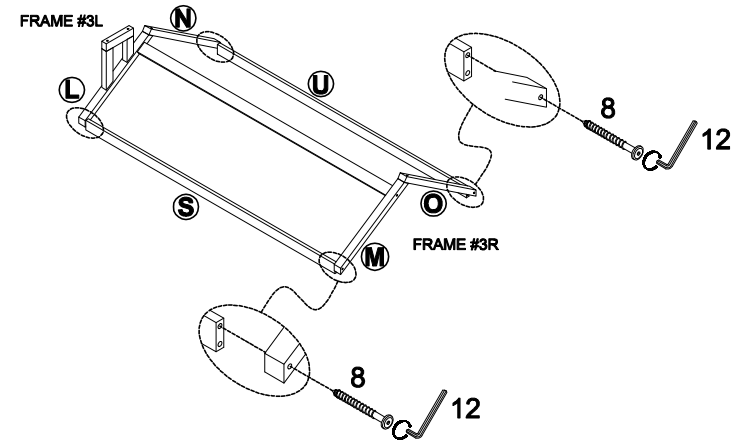



8	
4PCS	

NOTE: In this step, DO NOT tighten any bolt until you connect all part together

6

STEP 6: Following below illustration Assembly FRAME #6.

Using hardware #1 & #2 connect A and B Front-back left leg with E and F HB-FB Horizontal (lower-upper) and insert G HB-FB panel into the middle groove E HB-FB Horizontal (lower)
And using hardware #1 & #2 connect C and D Front-back right leg with E and F HB-FB Horizontal (lower-upper) and insert G HB-FB panel into the middle groove E HB-FB Horizontal (lower) to complete FRAME #6.

1	2
	
20PCS	20PCS

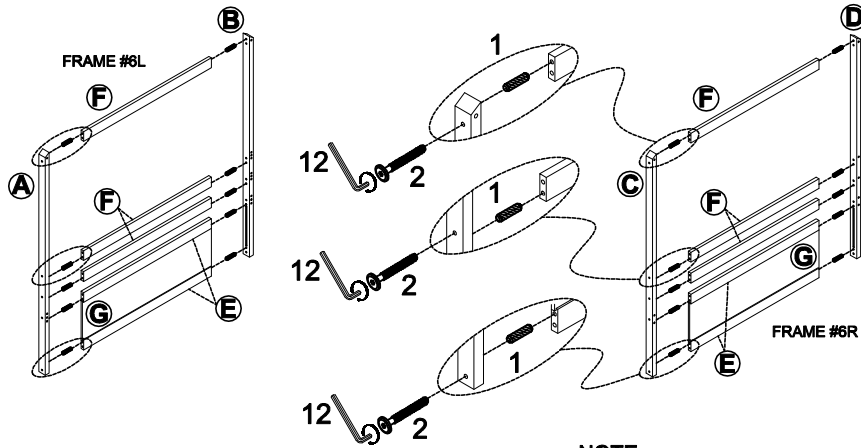

STEP 7: Following below illustration Assembly FRAME #7.

Using hardware #1, #3 & #4 connect FRAME #6L (A and B Front-back left leg) with H and I Front-back side rail and J Back horizontal, And using hardware #1, #3 & #4 connect FRAME #6R (C and D Front-back right leg) with H and I Front-back side rail and J Back horizontal to complete FRAME #7.

1	3	4
		
12PCS	12PCS	12PCS

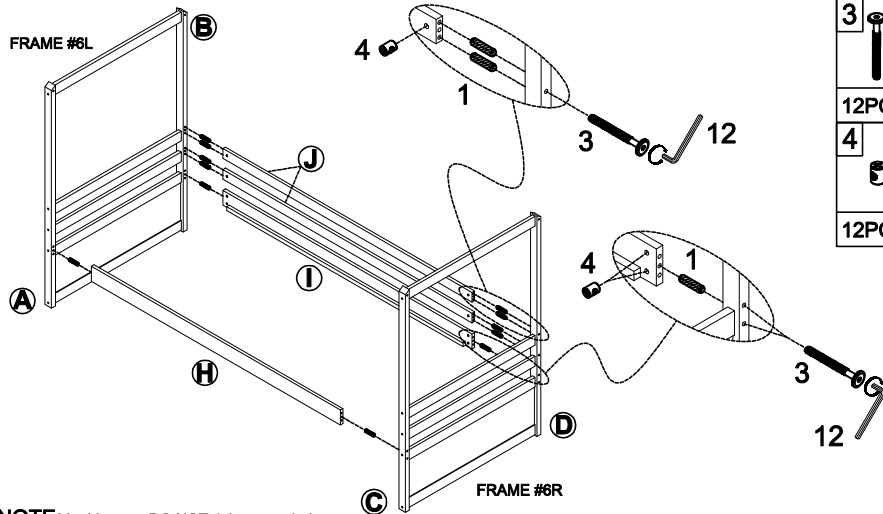

NOTE: In this step, DO NOT tighten any bolt until you connect all part together

7

STEP 8: Following below illustration Assembly FRAME #8.

Using hardware #6 connect K Back vertical with I Back side rail and J Back horizontal to complete FRAME #8.

6

3PCS

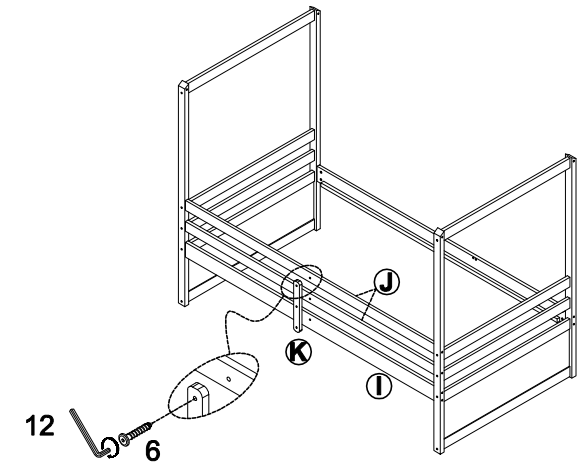

NOTE: In this step, DO NOT tighten any bolt until you connect all part together

STEP 9: Following below illustration Assembly FRAME #9.

Move the FRAME #5 put on the FRAME #8
Using hardware #8 connect A, B, C and D Leg of bed with S and U Horizontal (top front-back) to complete FRAME #9.

8

4PCS

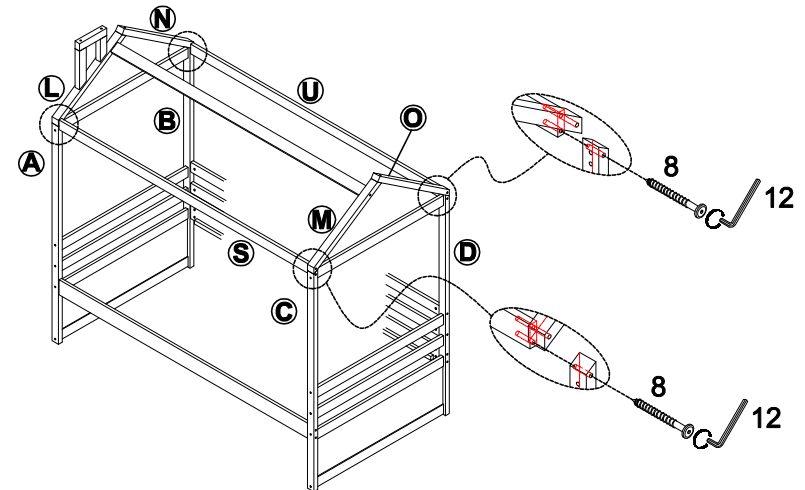

NOTE: In this step, DO NOT tighten any bolt until you connect all part together

8

STEP 10: Following below illustration Assembly FRAME #10.

Using hardware #6 connect V Front vertical with the Front frame W to complete FRAME #10.

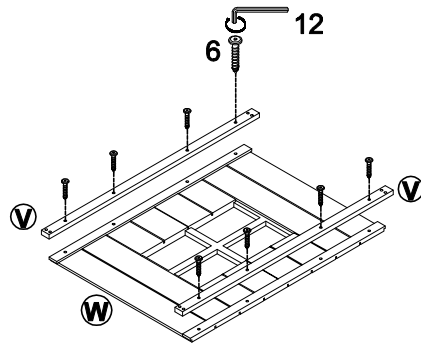
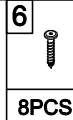

NOTE: In this step, DO NOT tighten any bolt until you connect all part together

STEP 11: Following below illustration Assembly FRAME #11.

Using hardware #6 connect V Front vertical with the FRAME #9 (H Front side rail and S Horizontal (top front) to complete FRAME #11.

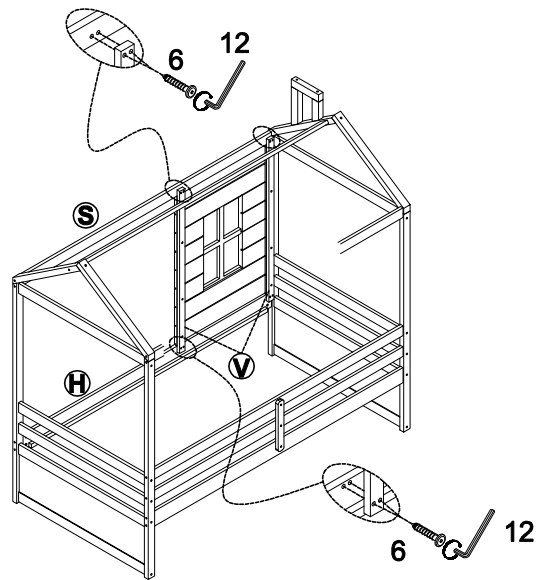
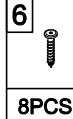

NOTE: In this step, DO NOT tighten any bolt until you connect all part together

9

STEP 12: Following below illustration Assembly FRAME #12.

Using hardware #10 connect to screw all Wood slats 15 with FRAME #11 on all the Bed. to complete FRAME #12.

WARNING:
Please completed screw all the slats in to side rails before using.

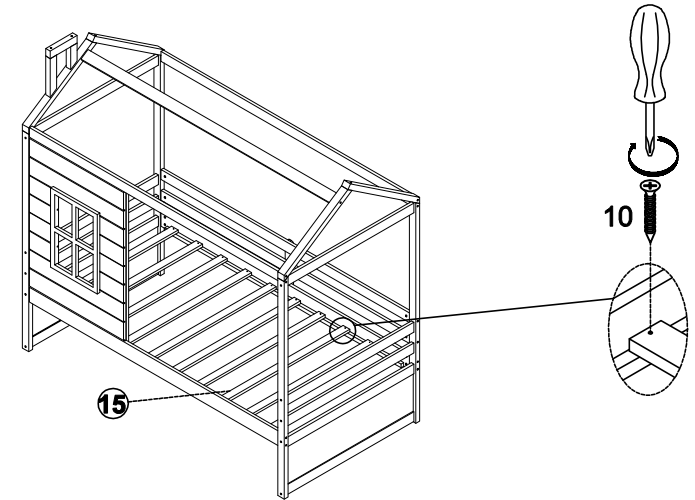
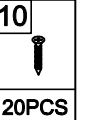

STEP 13: Following below illustration Assembly FRAME #13.

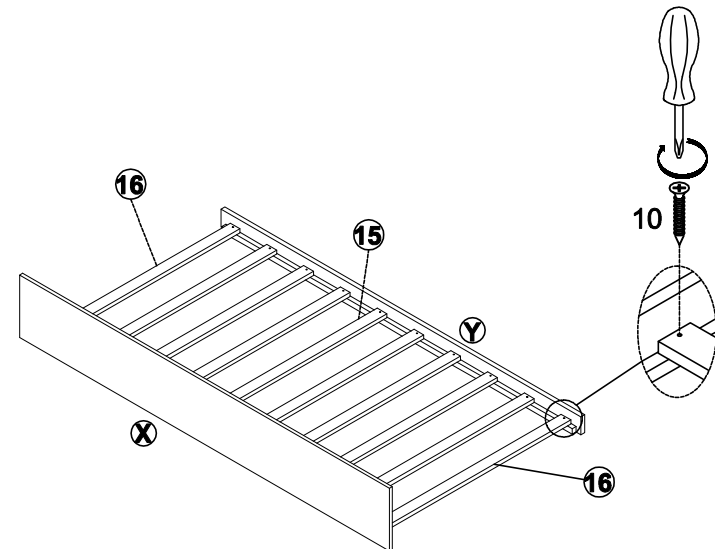
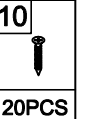

Using hardware #10 connect to screw all Wood slats 15 with X Drawer front and Y Drawer back on all the Bed. to complete FRAME #13.



10

STEP 14: Following below illustration Assembly FRAME #14.

Using hardware #9 connect #11 Wheel with (15) two the Slats on the outside to complete FRAME #14.

9	11
	
8PCS	4PCS

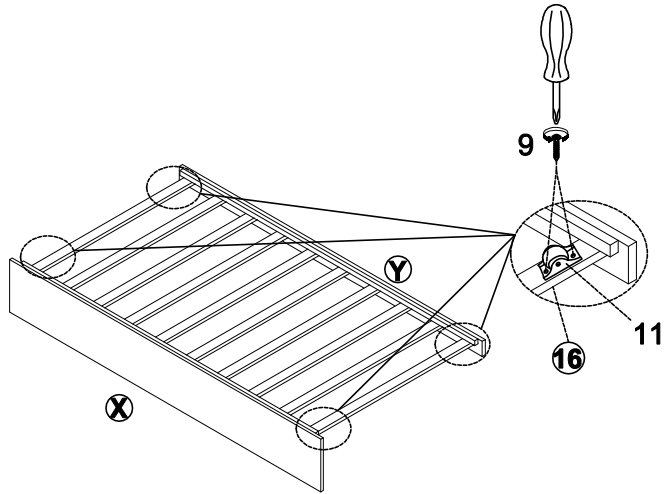

COMPLETED

