

# Assembly Instruction

## 4 TIER A FRAME BOOKCASE

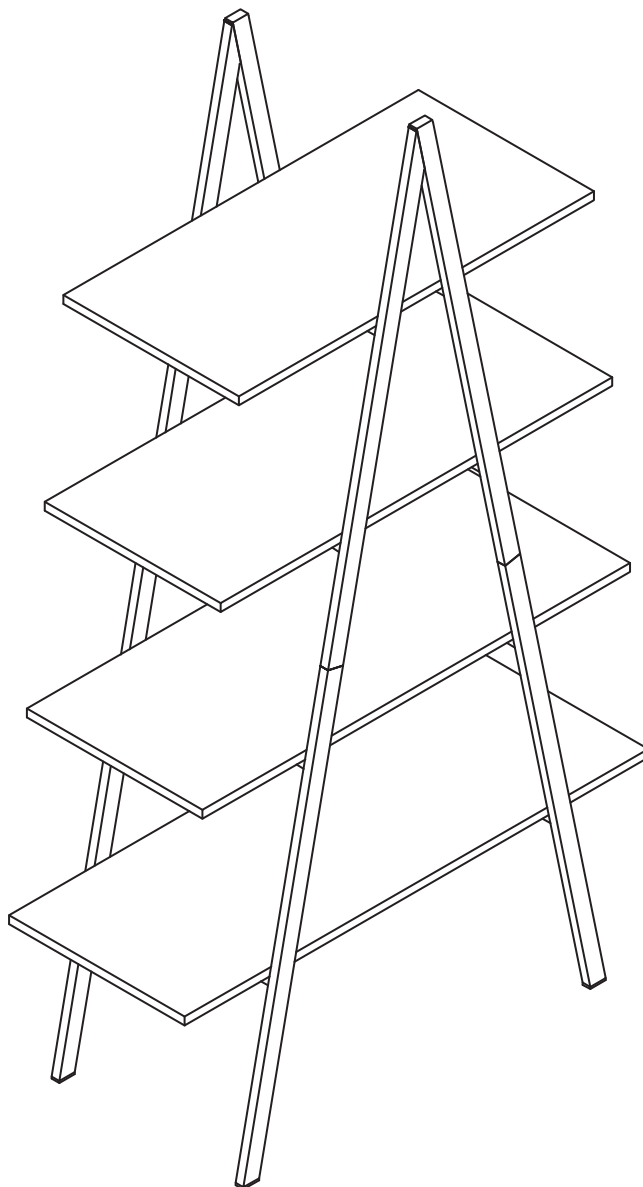

Carefully unpack and identify each component before beginning assembly. Before you begin, please refer to parts list to make sure that you have all parts. Please take care when assembling the unit and always place the parts on a clean, soft surface.

Get social with us and discover more about our products, tips and exclusive discounts!



**PRE-ASSEMBLY PREPARATION**







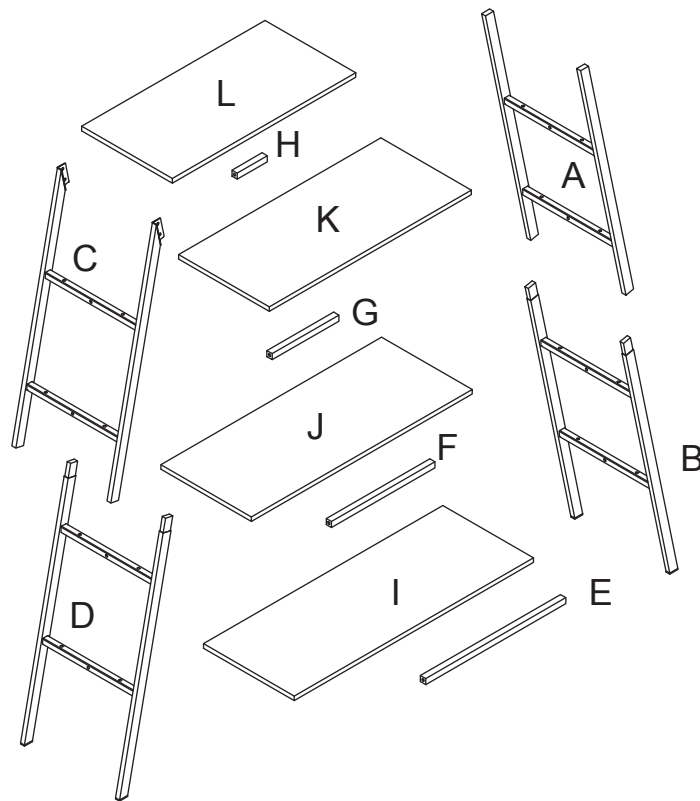



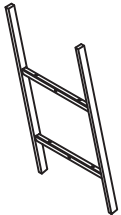
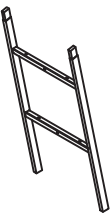
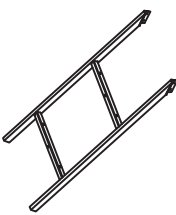
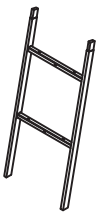
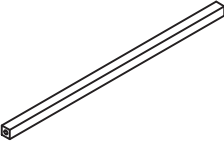
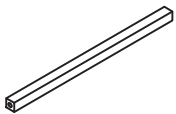
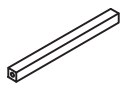

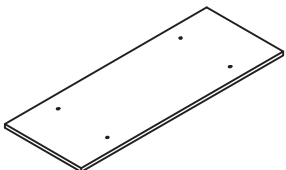
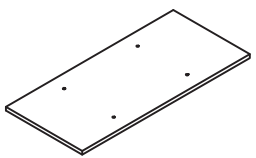
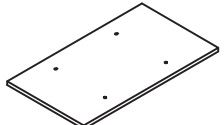
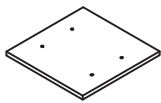
**WARNING: MAXIMUM LOAD NOT EXCEED 45LBS ON SHELVES.**

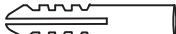

- **CAUTION:** Assembly will require at least 2 adults. Assemble on soft surface to prevent product finish from any damage. DO NOT use power tools.
- **CARE AND CLEANING:** DO NOT scratch or chip the finish. DO NOT use abrasive chemicals for cleaning. Clean with mild soap on a soft rag. Rinse and dry thoroughly.
- **MAINTENANCE:** Check bolts/screws periodically and tighten if necessary.
- **WARNING:** DO NOT USE If this product become damaged, and/or components are broken or missing.
- **REMINDER:** Please DO NOT fully tighten all bolts until metal frame assembly is complete.

**Explosive View**



PART	DESCRIPTION	QTY	PART	DESCRIPTION	QTY
<b>A</b>	RIGHT UPPER FRAME	1	<b>G</b>	MIDDIE SHORT SHELF CROSS BAR	1
<b>B</b>	RIGHT BOTTOM FRAME	1	<b>H</b>	TOP CROSS BAR	1
<b>C</b>	LEFT UPPER FRAME	1	<b>I</b>	BOTTOM PANEL	1
<b>D</b>	LEFT BOTTOM FRAME	1	<b>J</b>	MIDDIE LONG SHELF PANEL	1
<b>E</b>	BOTTOM CROSS BAR	1	<b>K</b>	MIDDIE SHORT SHELF PANEL	1
<b>F</b>	MIDDIE LONG SHELF CROSS BAR	1	<b>L</b>	TOP PANEL	1



PARTS LIST			
<p>Right upper frame (A)</p>  <p>Qty: 1</p>	<p>Right bottom frame (B)</p>  <p>Qty: 1</p>	<p>Left upper frame (C)</p>  <p>Qty: 1</p>	<p>Left bottom frame (D)</p>  <p>Qty: 1</p>
<p>Bottom cross bar (E)</p>  <p>Qty: 1</p>	<p>Middle long shelf cross bar (F)</p>  <p>Qty: 1</p>	<p>Middle short shelf cross bar (G)</p>  <p>Qty: 1</p>	<p>Top cross bar (H)</p>  <p>Qty: 1</p>
<p>Bottom panel (I)</p>  <p>Qty: 1</p>	<p>Middle long shelf panel (J)</p>  <p>Qty: 1</p>	<p>Middle short shelf panel (K)</p>  <p>Qty: 1</p>	<p>Top panel (L)</p>  <p>Qty: 1</p>
HARDWARE LIST			
<p>ALLEN BOLT (1)</p>  <p>M6*10mm</p> <p>Qty: 8</p>	<p>ALLEN BOLT (2)</p>  <p>M6*30mm</p> <p>Qty: 24</p>	<p>ALLEN WRENCH (3)</p>  <p>4mm</p> <p>Qty: 1</p>	<p>STEEL PLATE (4)</p>  <p>13*11*24mm</p> <p>Qty: 2</p>
<p>ANTI-TIPPING STRIP (5)</p>  <p>5*200mm</p> <p>Qty: 1</p>	<p>WALL ANCHOR (6)</p>  <p>Ø8.5*30mm</p> <p>Qty: 1</p>	<p>PHILLIPS SCREW (7)</p>  <p>Ø4*25mm</p> <p>Qty: 1</p>	<p>ALLEN BOLT (8)</p>  <p>M6*12mm</p> <p>Qty: 4</p>
<p>NOT INCLUDED</p> 			

REQUIRED HARDWARE IN THIS STEP			
NO.	DESCRIPTION	SKETCH	QTY
1	ALLEN BOLT M6*10mm		8PCS
3	ALLEN WRENCH		1PC

**STEP 1**

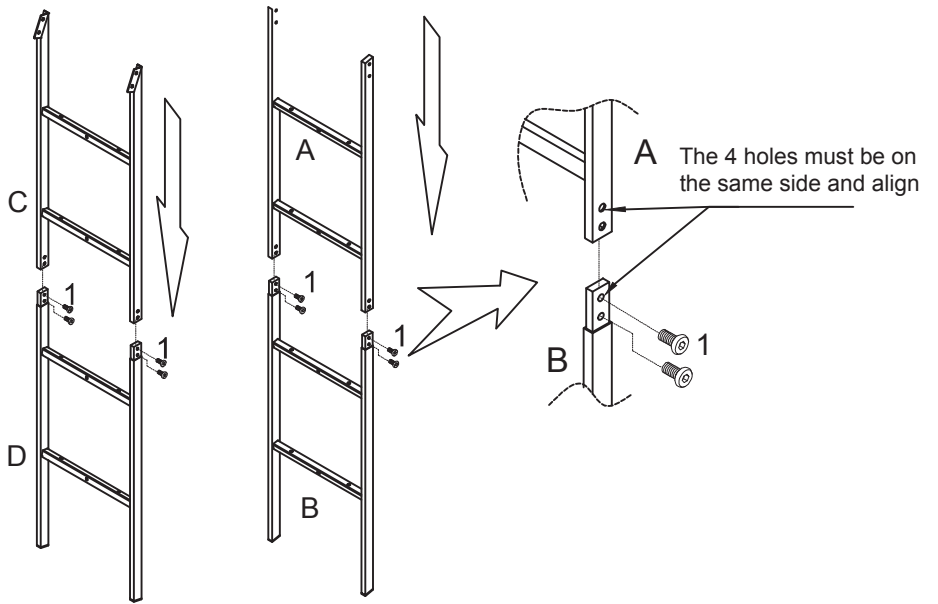
Attach right upper frame (A) on right bottom frame (B) with Allen bolts (1) and Allen wrench (3). Repeat this action for left upper Repeat this action for left upper (D).





REQUIRED HARDWARE IN THIS STEP			
NO.	DESCRIPTION	SKETCH	QTY
8	ALLEN BOLT M6*12mm		3PCS
3	ALLEN WRENCH		1PC

**STEP 2**

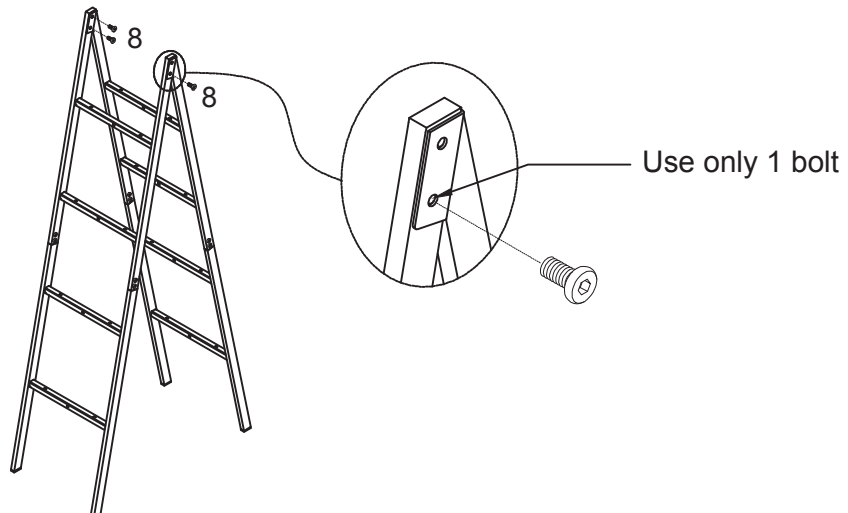
Slide the end of right upper frame (A) into the end of left upper frame (C) so the holes align. Secure the frame together with allen bolt (8) using allen wrench (3). Leave the bolt out of the top hole on the outside.





REQUIRED HARDWARE IN THIS STEP			
NO.	DESCRIPTION	SKETCH	QTY
2	ALLEN BOLT M6*30mm		8PCS
3	ALLEN WRENCH		1PC

**STEP 3**

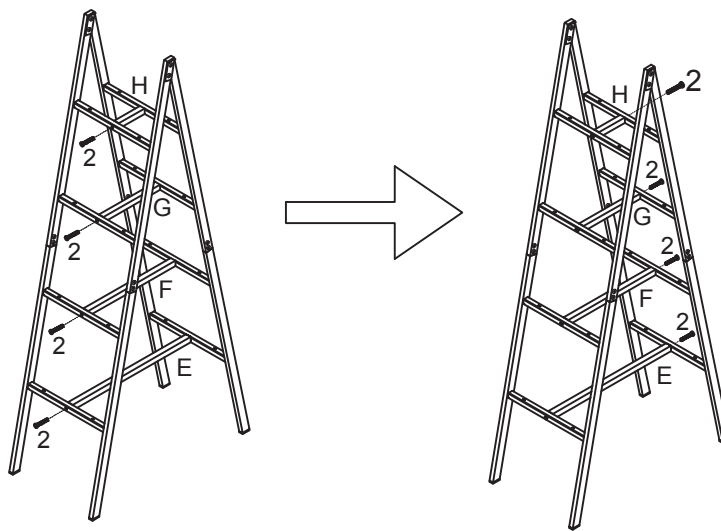
Attach top cross bar (H), middle short shelf cross bar (G), middle long shelf cross bar (F) and bottom cross bar (E) with allen bolt (2) using allen wrench (3). DO NOT fully tighten bolts until all cross bars are attached.





REQUIRED HARDWARE IN THIS STEP			
NO.	DESCRIPTION	SKETCH	QTY
2	ALLEN BOLT M6*30mm		16PCS
3	ALLEN WRENCH		1PC

**STEP 4**

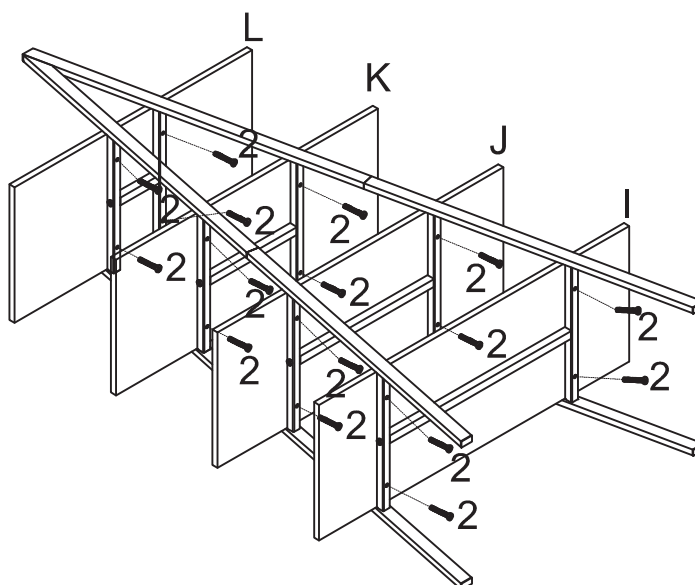
Attach top panel (L), middle short shelf panel (K), middle long shelf panel (J) and bottom panel (I) to the assembled frame as shown in the diagram with allen bolt (2) using allen wrench (3). Fully tighten all bolts.





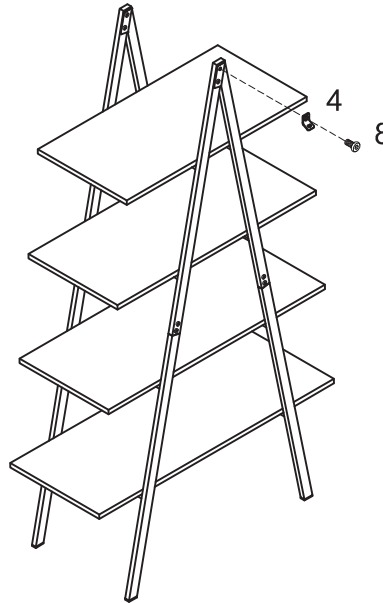

REQUIRED HARDWARE IN THIS STEP			
NO.	DESCRIPTION	SKETCH	QTY
8	ALLEN BOLT M6*12mm		1PC
4	STEEL PLATE		1PC
3	ALLEN WRENCH		1PC

**STEP 5**

Attach steel plate (4) to the hole left open on the outside of the top frame with allen bolt (8) using allen wrench (3).



REQUIRED HARDWARE IN THIS STEP			
NO.	DESCRIPTION	SKETCH	QTY
4	STEEL PLATE		1PC
5	ANTI-TIPPING STRIP		1PC
6	WALL ANCHOR Ø8.5*30mm		1PC
7	PHILLIPS SCREW Ø4*25mm		1PC

**STEP 6**

Place the shelves in the desired location. Mark the spot where the steel plate (4) meets the wall. Remove the shelves. Drill a hole at the marked location and insert the wall anchor (6). Attach the remaining steel plate (4) to wall anchor (6) using phillips screw (7). Return the shelves to the desired position and attach the steel plates (4) with anti-tipping strip (5). Assembly is now complete.

