

PARTS LIST / LISTE DES PIÈCES

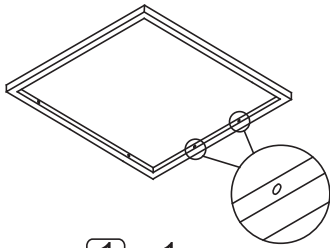

1 x1

Seat Panel with the Holes
Panneau de siège avec trous

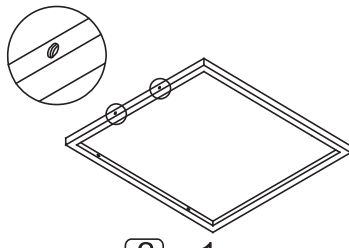

2 x1

Seat Panel with welding Nut
Panneau de siège avec écrou de soudage

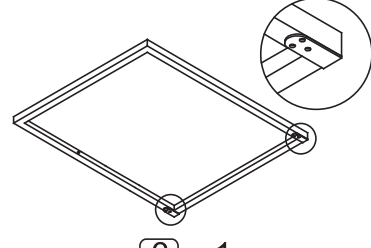

3 x1

Backrest panel
Panneau de dossier

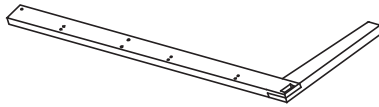

4 x1

Right - Front Rail
Rail avant droit

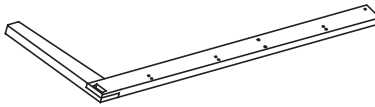

5 x1

Left - Front Rail
Rail avant gauche



6 x1

Front Apron
Tablier avant

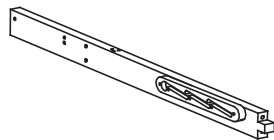

7 x1

Right - Back Rail
Rail arrière droit

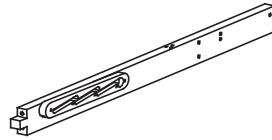

8 x1

Left - Back Rail
Rail arrière gauche



9 x1

Back Apron
Tablier arrière

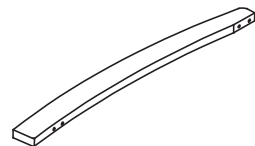

10 x1

Right Armrest
Accoudoir droit

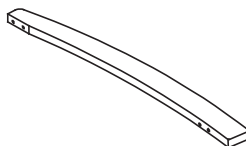

11 x1

Left Armrest
Accoudoir gauche

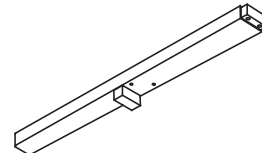

12 x1

Right - Front Leg
Pied avant droit

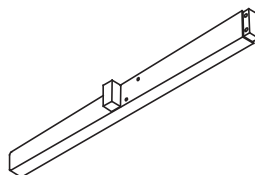

13 x1

Left - Front Leg
Pied avant gauche

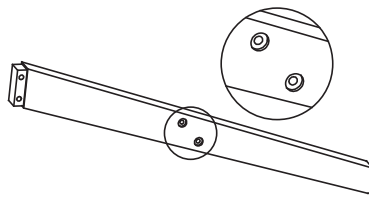

14 x1

Right - Back Leg
Pied arrière droit

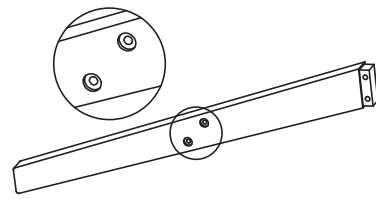

15 x1

Left - Back Leg
Pied arrière gauche



16 x2
Steel Stretcher
Civière en acier

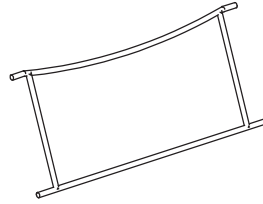

17 x1
Adjustment frame
Cadre de réglage



M4x20mm
Screw/Vis
A x6



M4x35mm
Screw/Vis
B x8

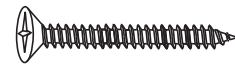

M5x50mm
Screw/Vis
C x4



M4x15mm
Screw/Vis
D x16

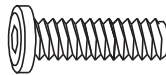

M6x30mm
Bolt/Boulon
E x4

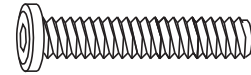

M6x45mm
Bolt/Boulon
F x4

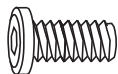

M6x13mm
Bolt/Boulon
G x8

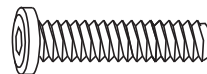

M6x40mm
Bolt/Boulon
H x2

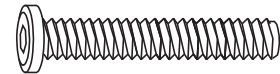

M6x50mm
Bolt/Boulon
I x4

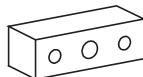

Wooden Block Connector/
Connecteur de bloc en bois
J x2

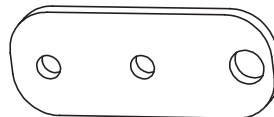

Metal Hinge/
Charnière en métal
K x8



M6x20x5mm
Washer/Rondelle
L x4

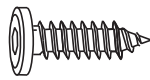

M6x15mm

Ⓜ x8

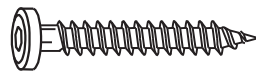

M6x60mm

Ⓝ x2

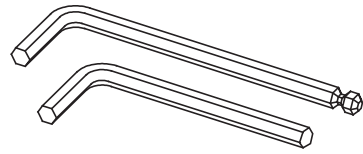

Allen key

Ⓞ x2

Please don't fasten the screw completely during assembly process.

It will be likely to lead to an assembling problem that screw hole position is not aligned.

You can fasten completely when all parts have been assembled.

Veillez ne pas serrer complètement la vis pendant le processus d'assemblage. Cela entraînera probablement un problème d'assemblage si la position du trou de vis n'est pas alignée.

Vous pouvez fixer complètement lorsque toutes les pièces ont été assemblées.

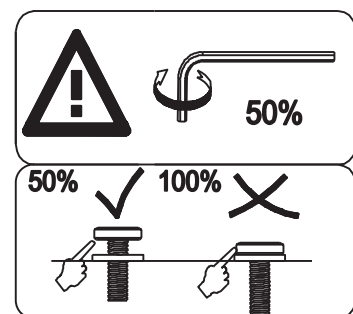

1

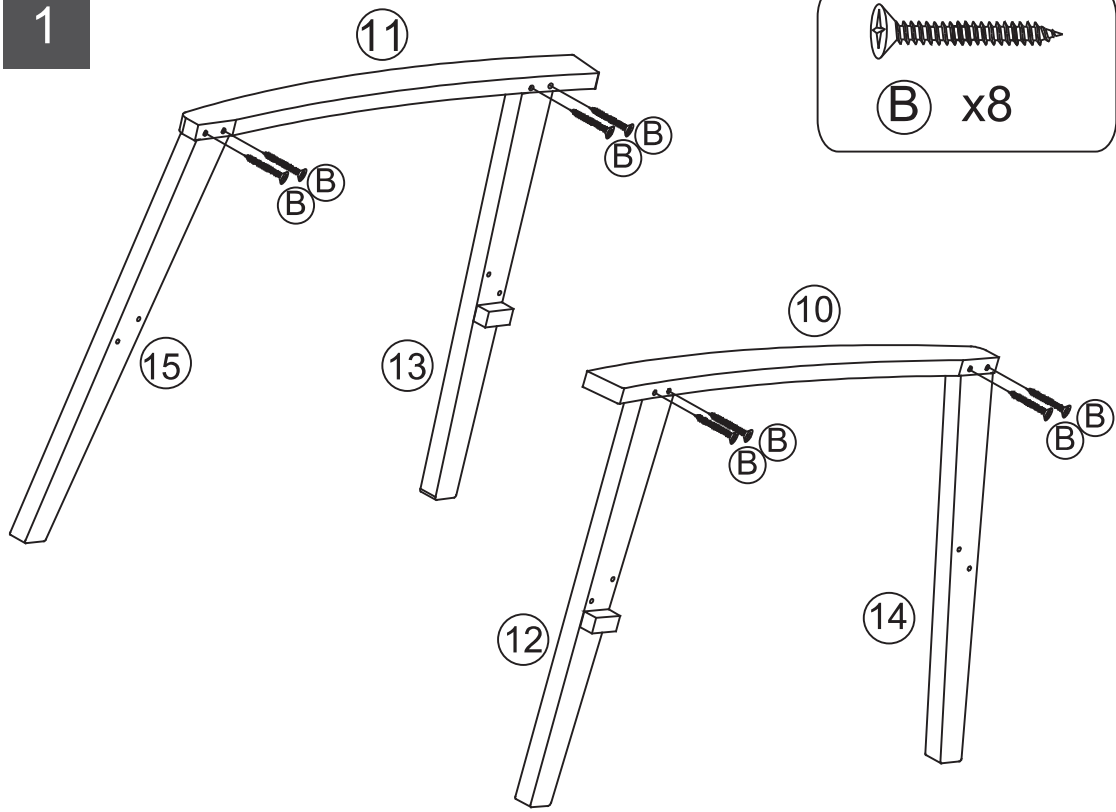

2

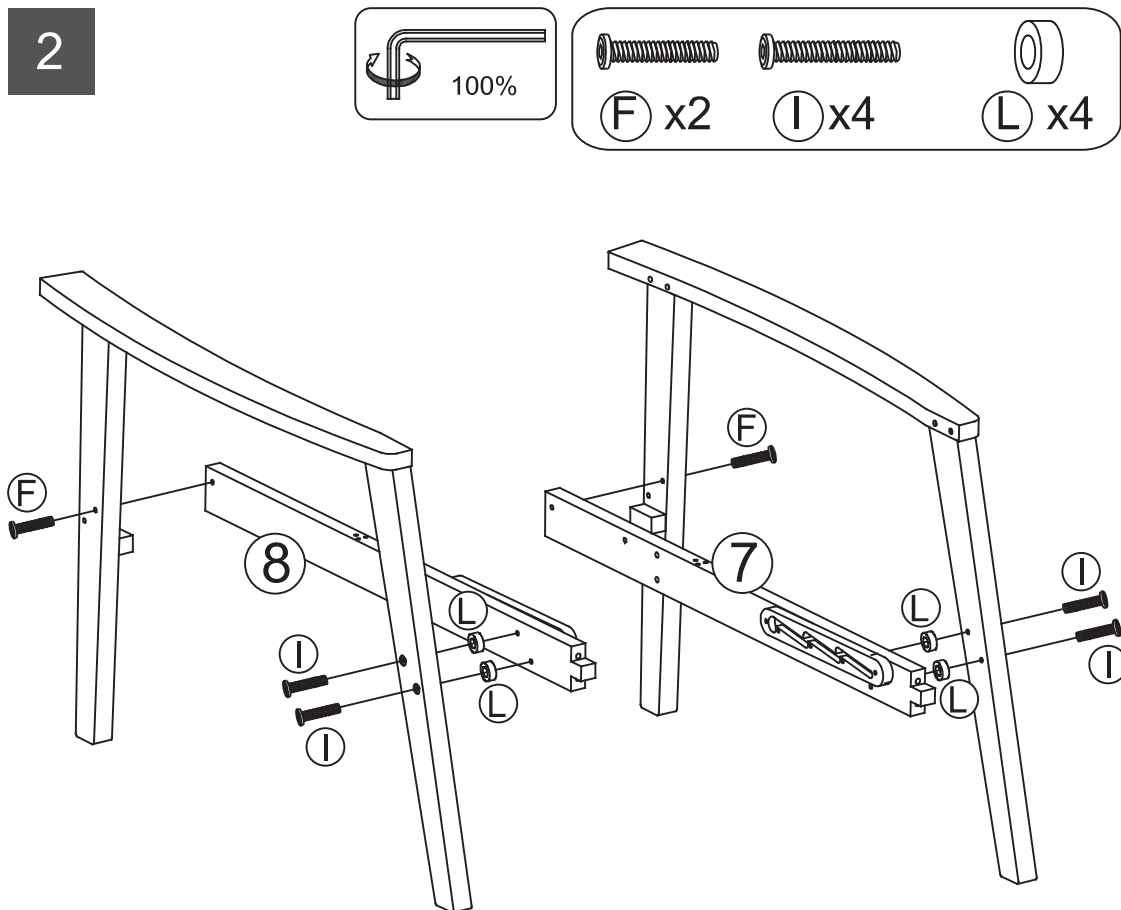

3

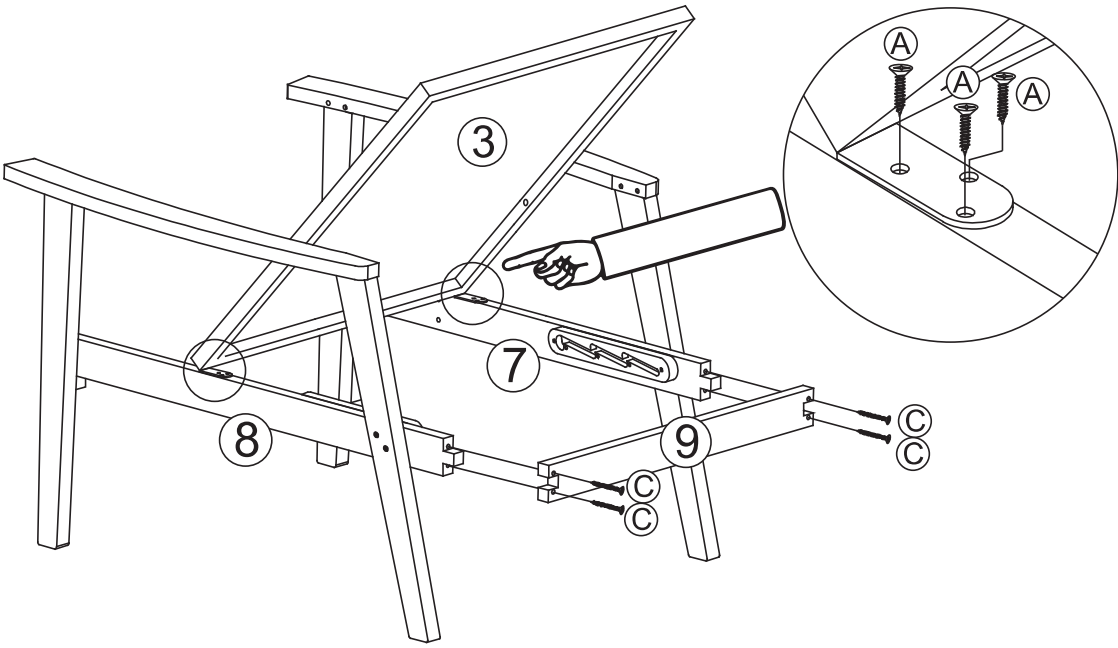
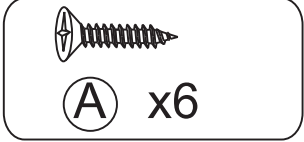
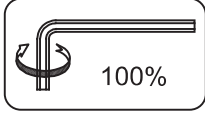

4

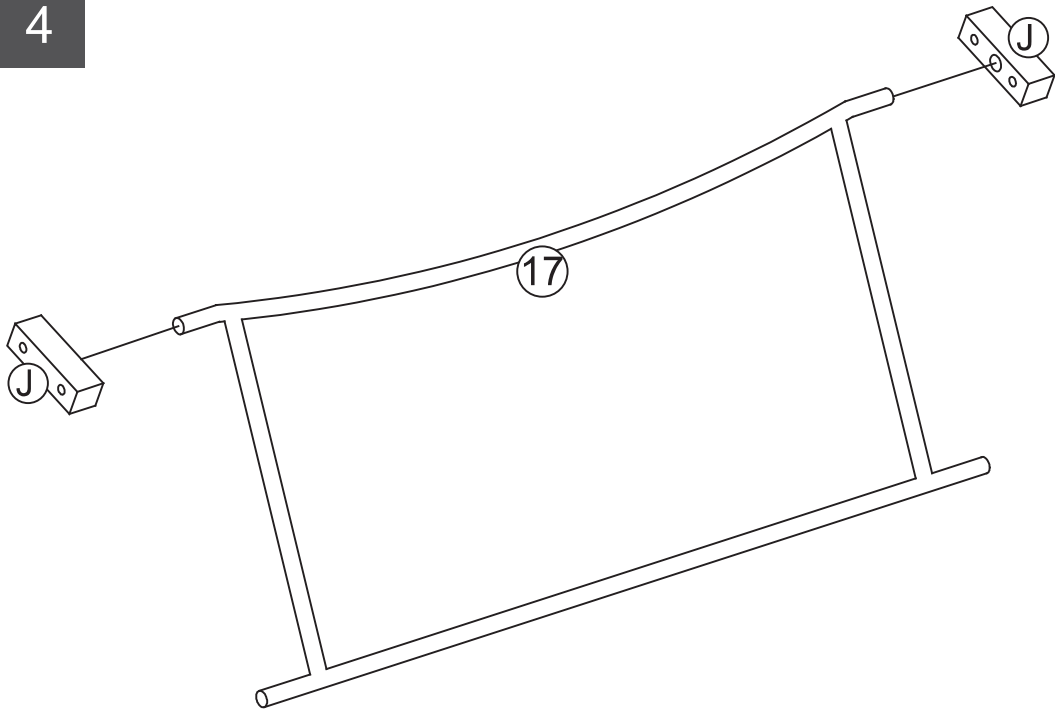

5

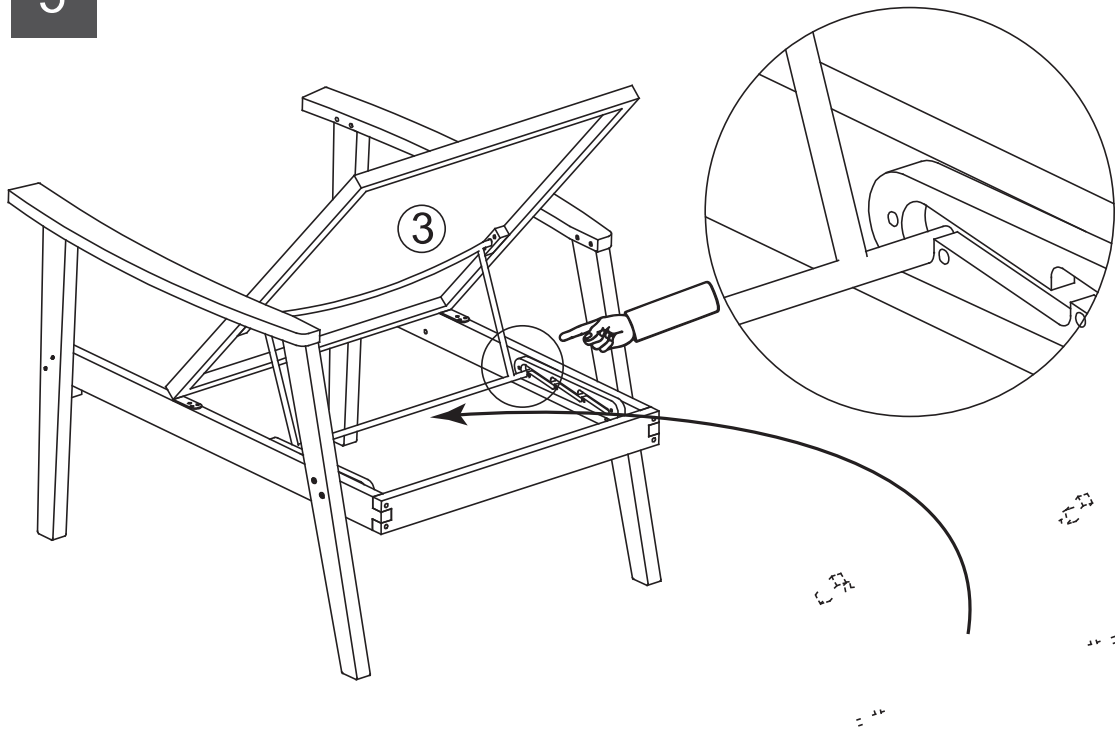

6

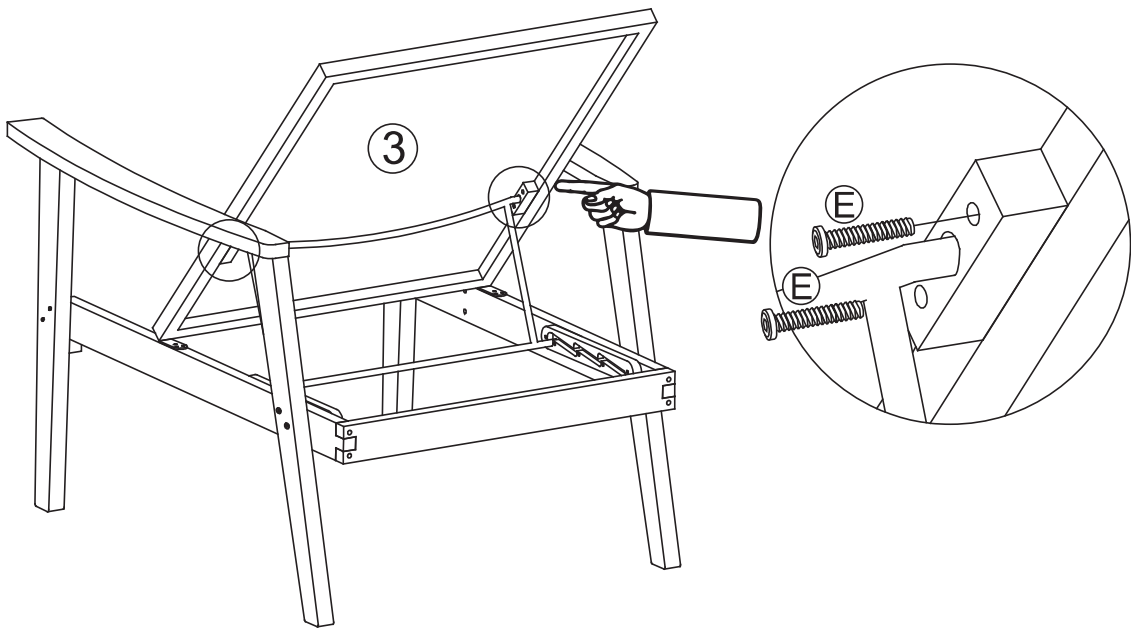
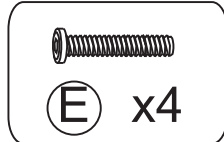
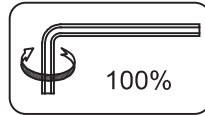

7

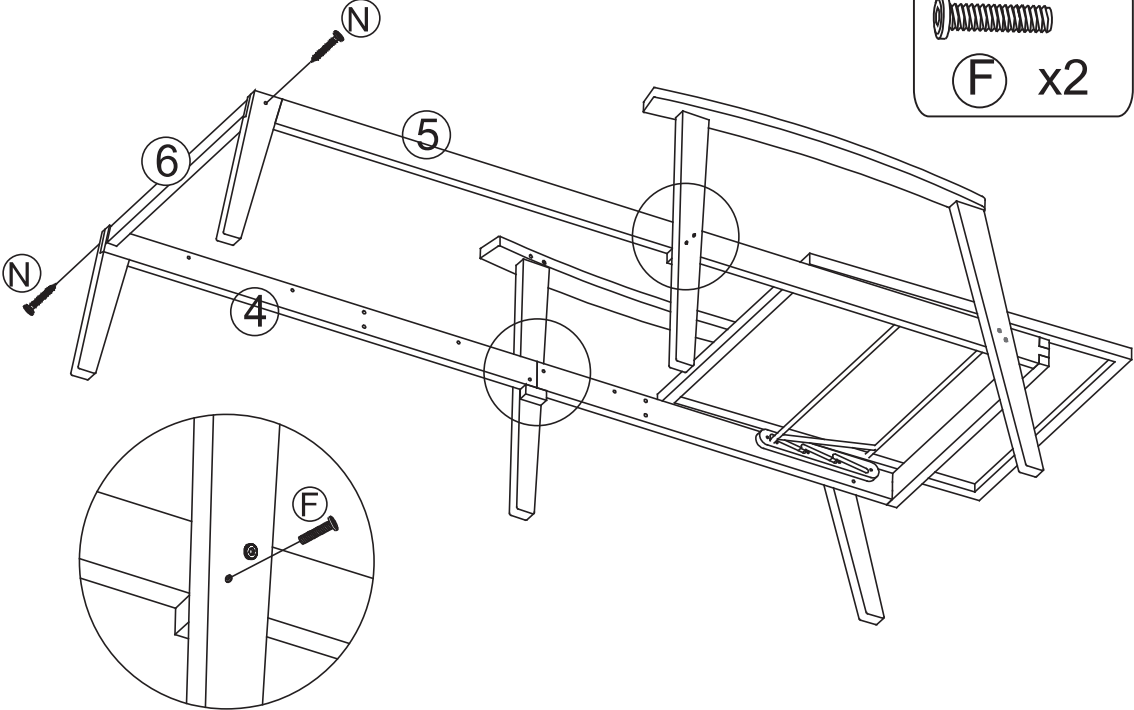
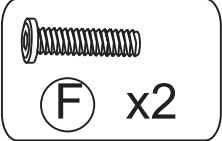
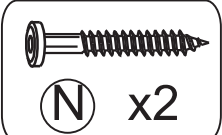
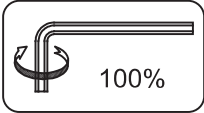

8

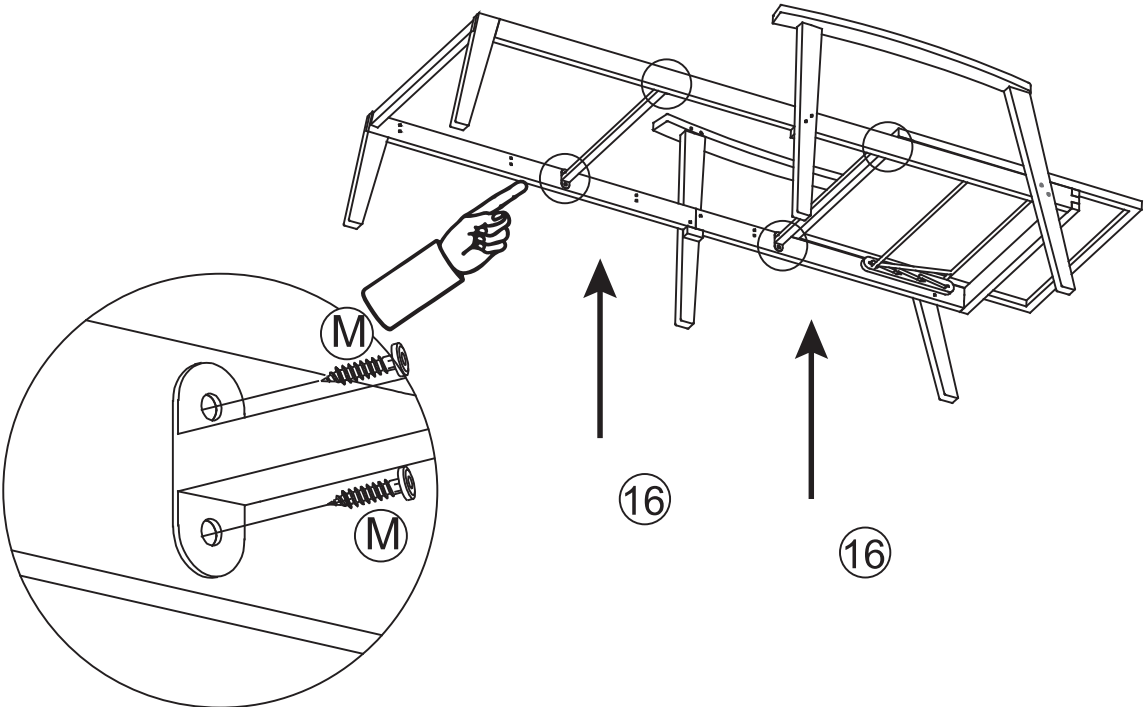
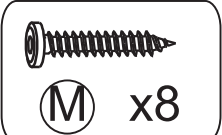
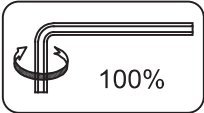

9

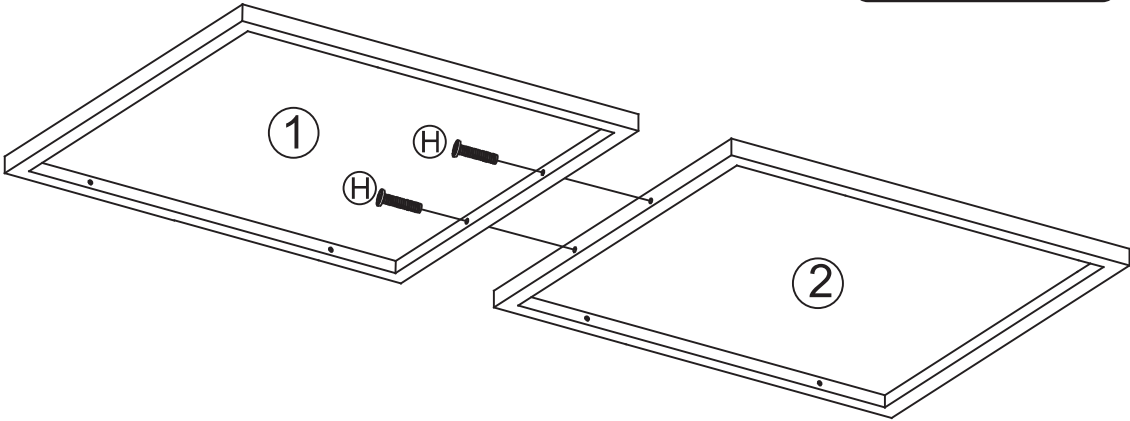
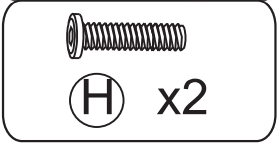
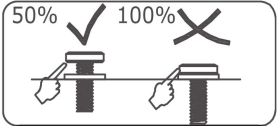
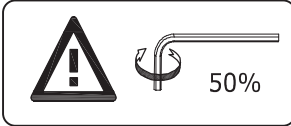

10

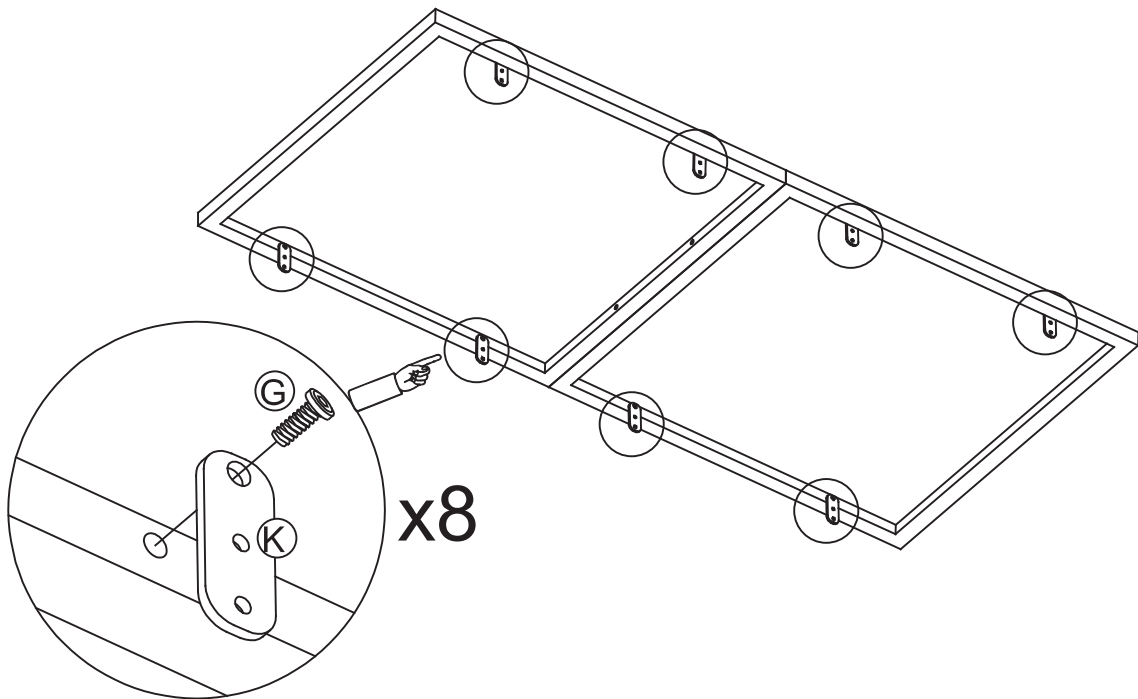
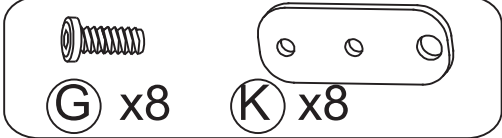
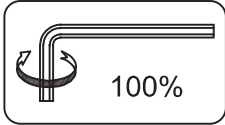

11

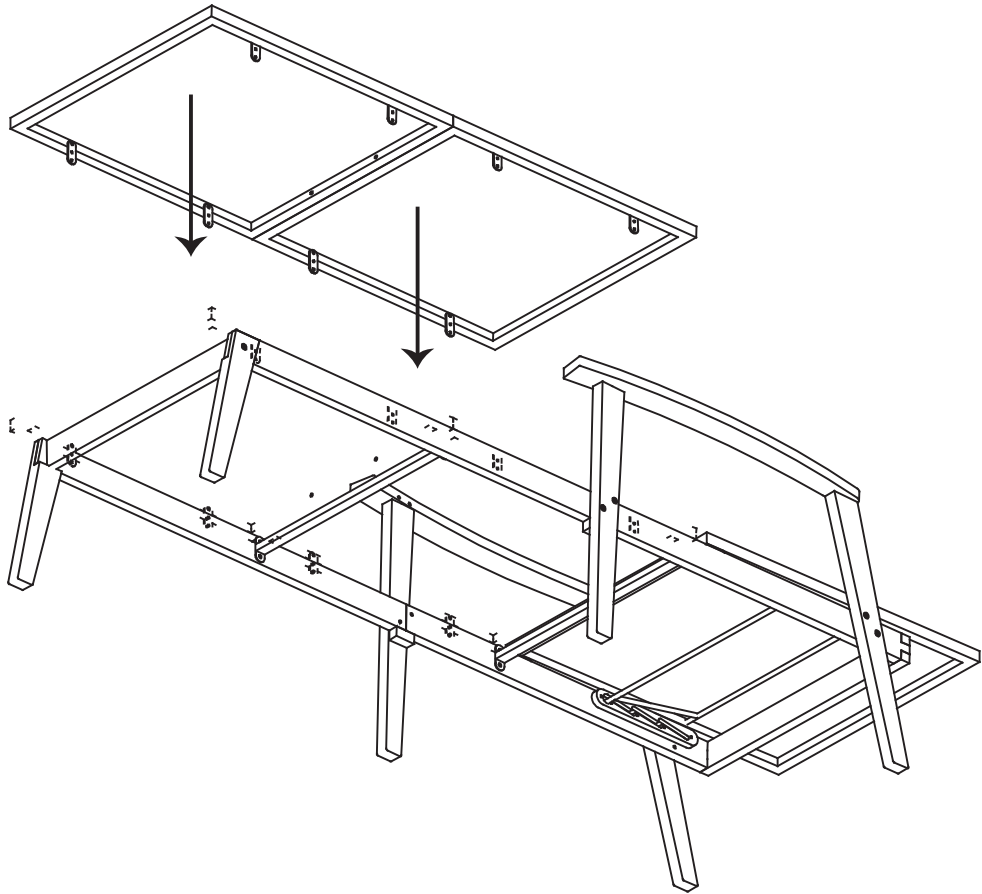

12

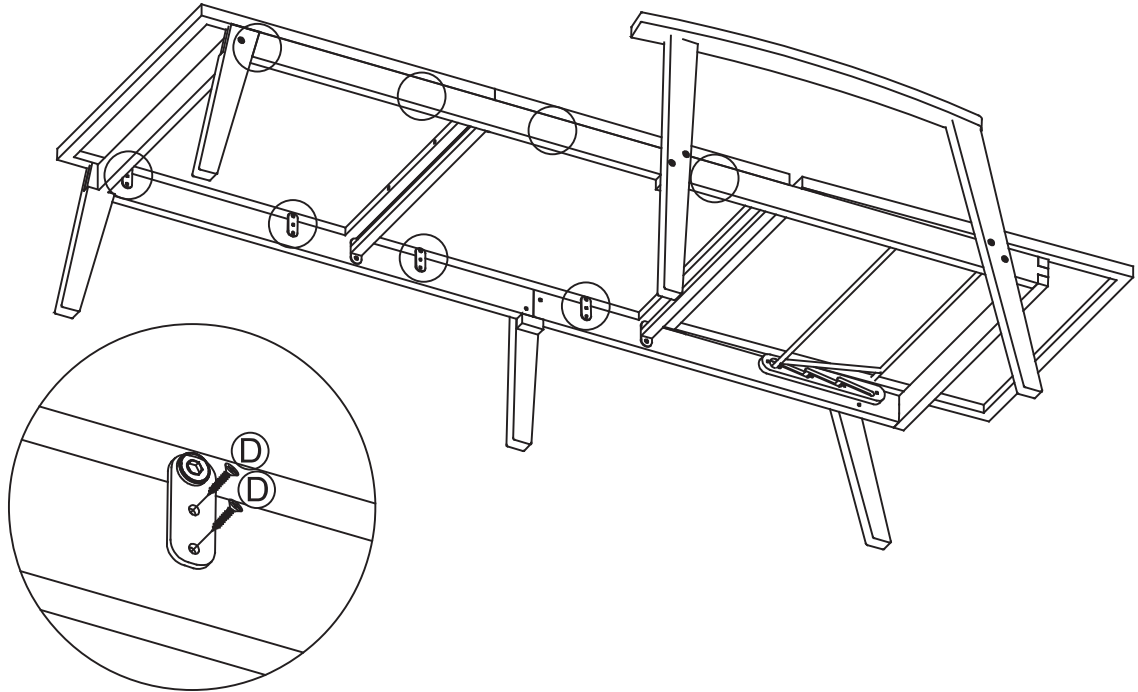
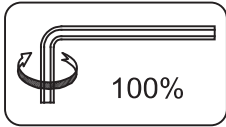

13

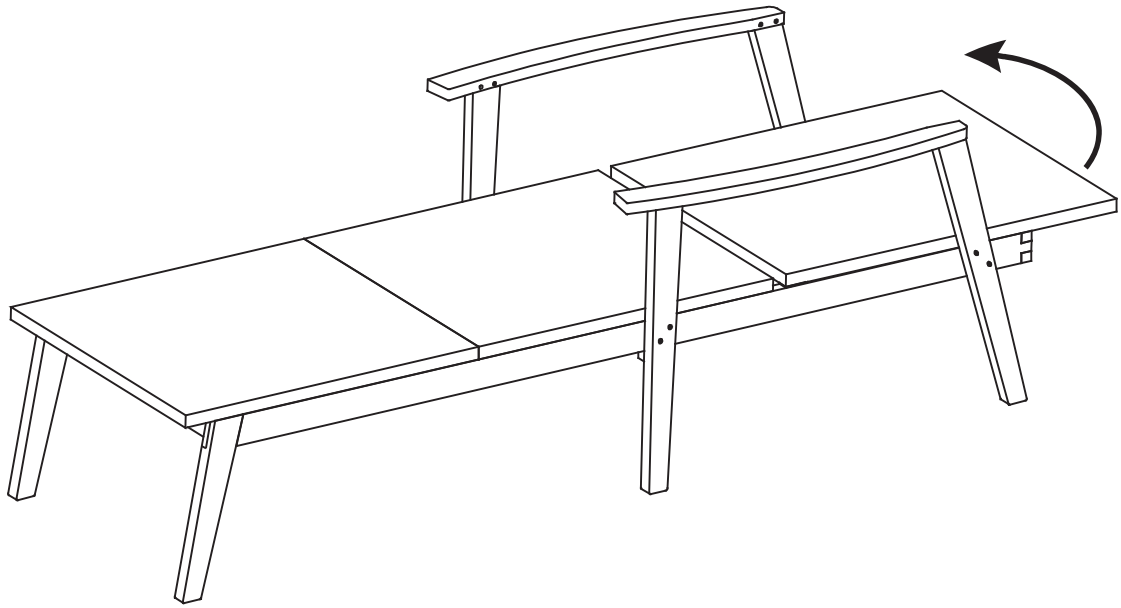

14

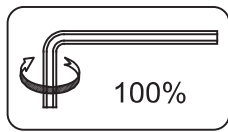

100%

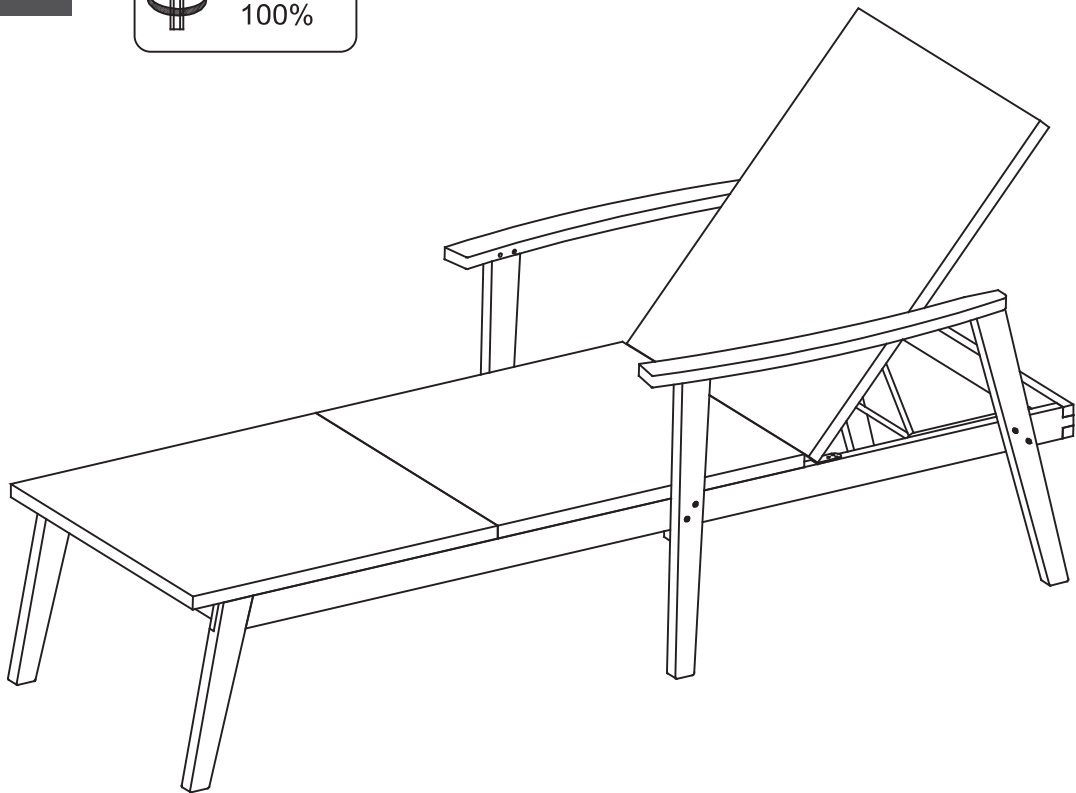

15

EN: The backrest can be adjusted for feeling comfortable.

FR: Le dossier peut être ajusté pour se sentir à l'aise.

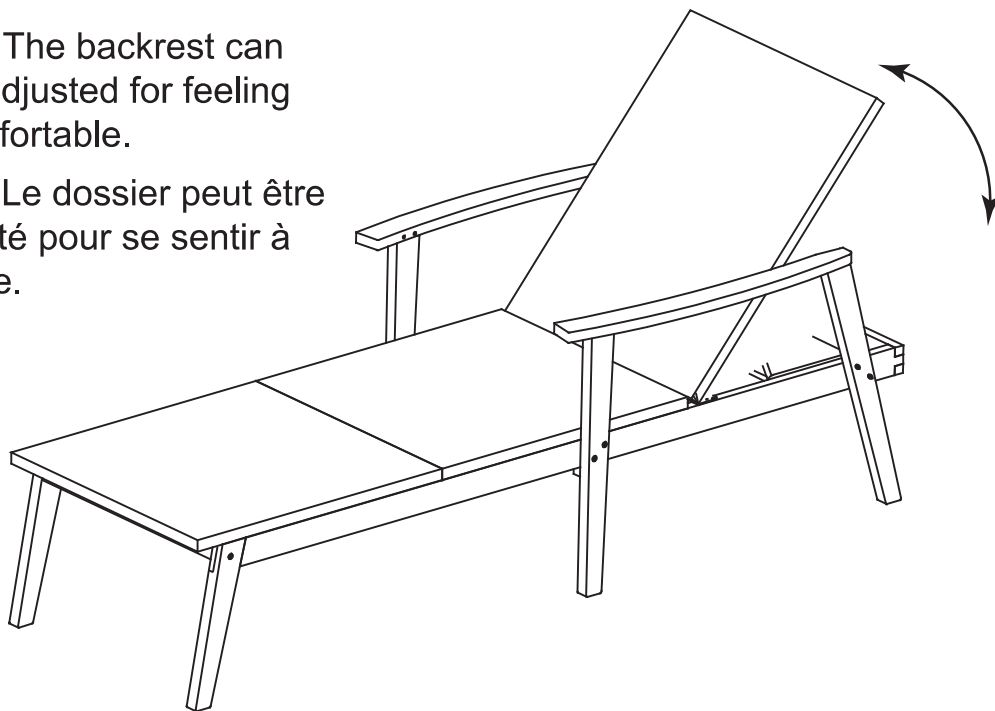

16

Finished / Terminé

