



.....

Small

Kids Locker

.....

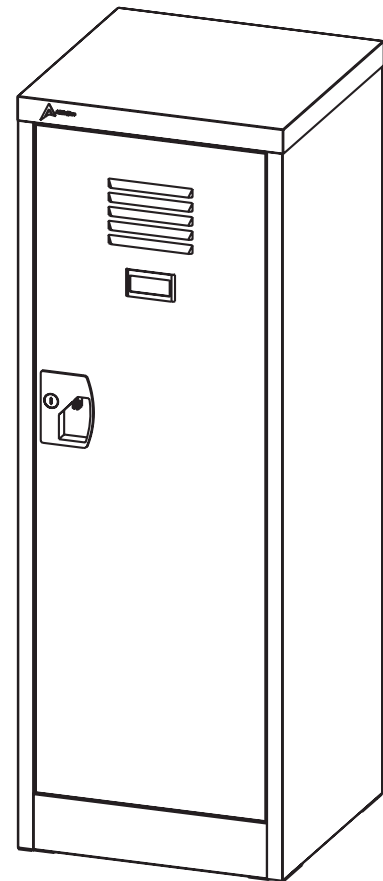

ADI629-02-SERIES

USER GUIDE



Thank you for your purchase.

.....

**AdirOffice has a commitment to
deliver quality and stylish office
furniture and equipment.**

.....

We understand starting and maintaining a business is expensive enough.
We can help you make it cost effective and beautiful. Plus, our expert team
makes sure everything you need works as efficiently as possible.

Table of Contents

- 1** Parts List
- 2** Assembly Instructions
- 9** Mounting Instructions
- 10** Notes
- 11** Limited Warranty
- 12** Disclaimer

Parts Included

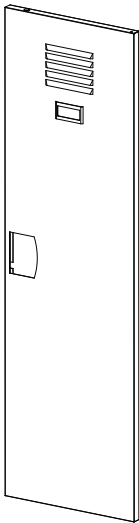

Door (1)

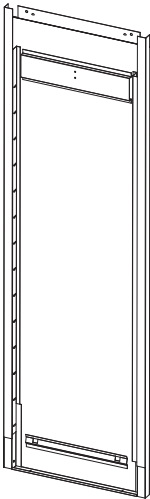

Left Side Panel (2)

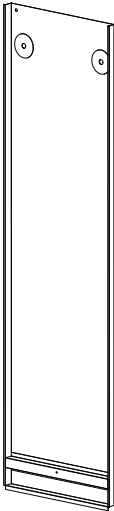

Back Panel (3)

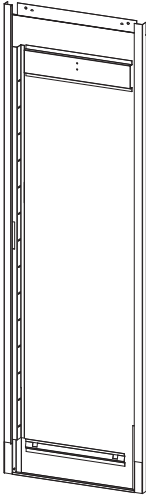

Right Side Panel (4)

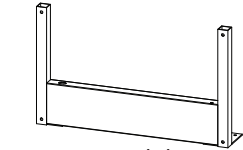

Front Leg (5)

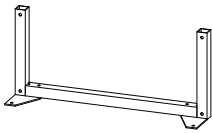

Back Leg (6)

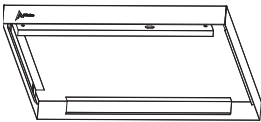

Top Panel (7)

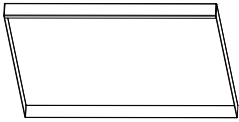

Base (8)



2x Double Hook (A)



4x Big Screws (B)



4x Small Screws (C)



Keys (D)



Large Hinge Pin (E)



Small Hinge Pin (F)

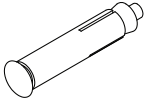

2x Wall Anchor Screw (G)



2x Rubber Buffer (H)



Plastic Hinge Bush (I)

Assembly Instructions

STEP 1:

Turn the Left Side Panel (2) and the Right-Side Panel (4) upside-down. Insert the Back Leg (6) into the shorter holes of both side panels, apply pressure. Insert the Front Leg (5) into the deeper slots and apply pressure. Insert all four Big Screws (B) into the bottom of the legs.

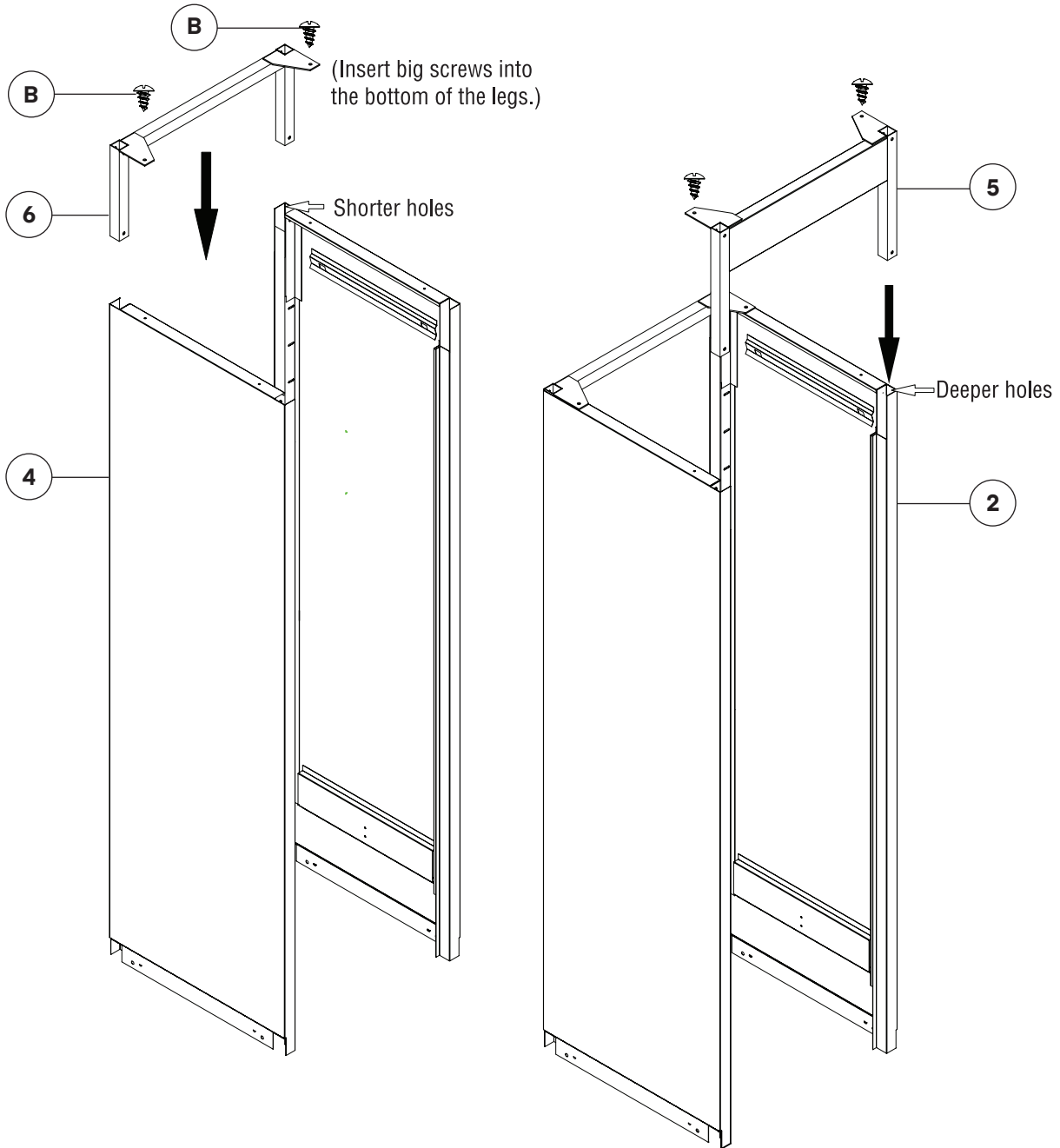

Assembly Instructions

STEP 2:

Flip the locker to the upright position and align the Back Panel (3) between Left Side Panel (2) and the Right-Side Panel (4).

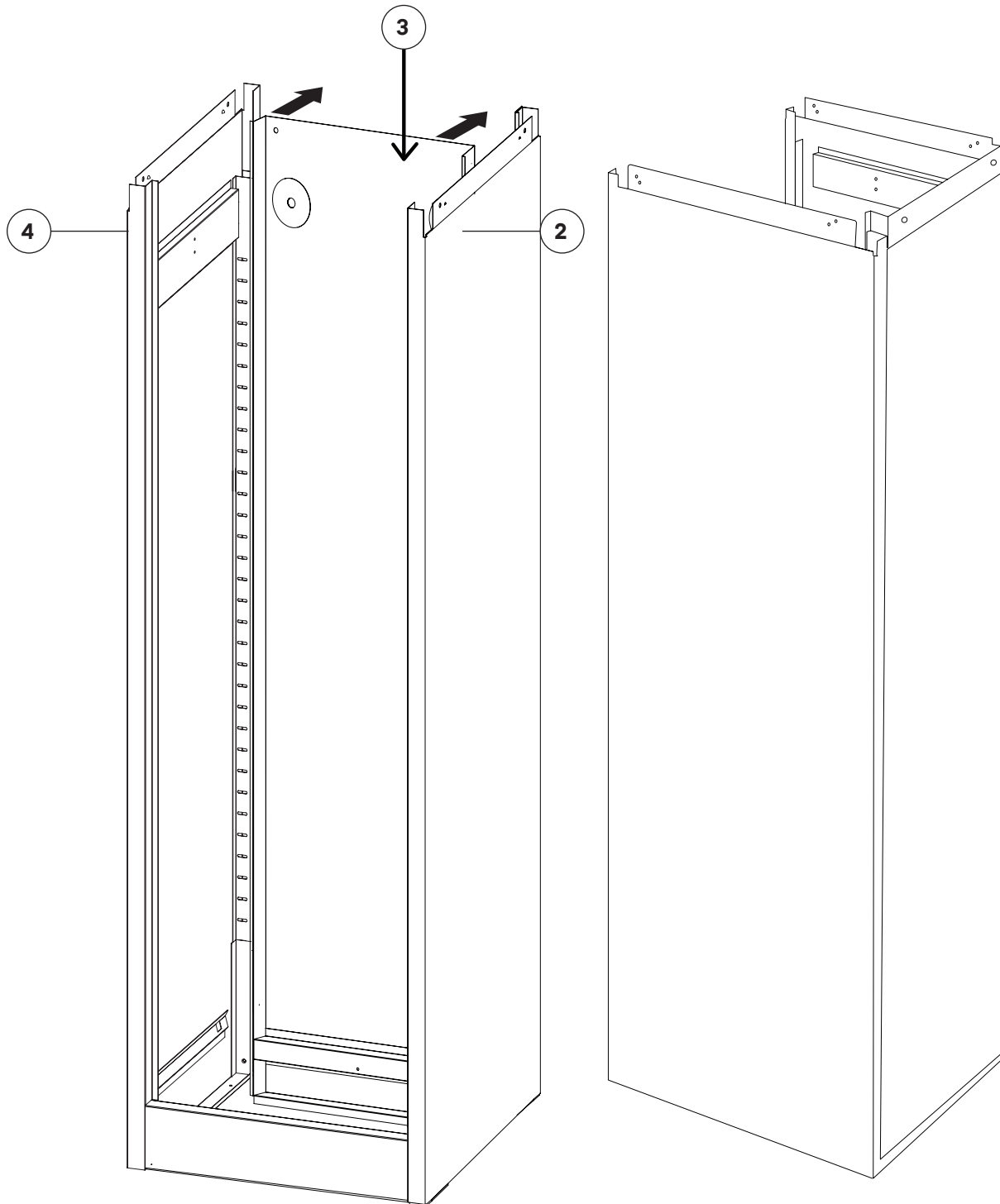

Assembly Instructions

STEP 3:

Insert the Top Panel (7) onto the locker. Ensure that the locker's edges are aligned with the lips found underneath the Top Panel (7). Push the top portion into place by applying some pressure. Make sure all edges snap in firmly.

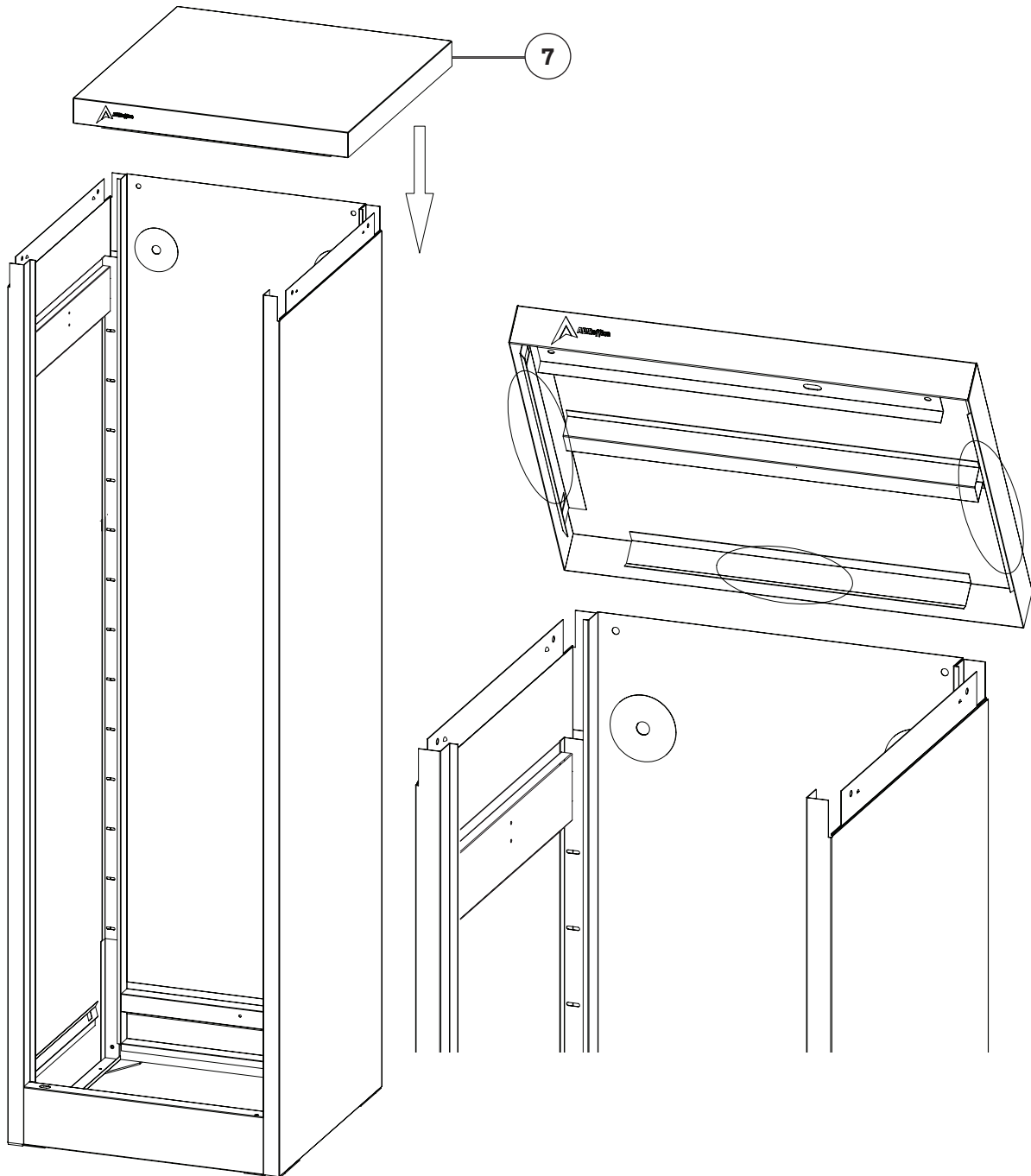

Assembly Instructions

STEP 4:

Insert the Plastic Hinge Bush (I) in the hole on the bottom right of the locker's Front Leg (5).

Insert the Small Hinge Pin (F) in the hole on top of the locker door (See Figure 1 on the next page).

Insert the Small Hinge Pin (F) with the Door (1) in the hole located under the right side of the Top Panel (7). (See Figures 2 and 3 on the next page.)

Next, take the Large Hinge Pin (E), insert it into the hole on the bottom of the Door (1), lock it into place by passing it through the slot on the Door (1). (See Figures 4, 5, 6).

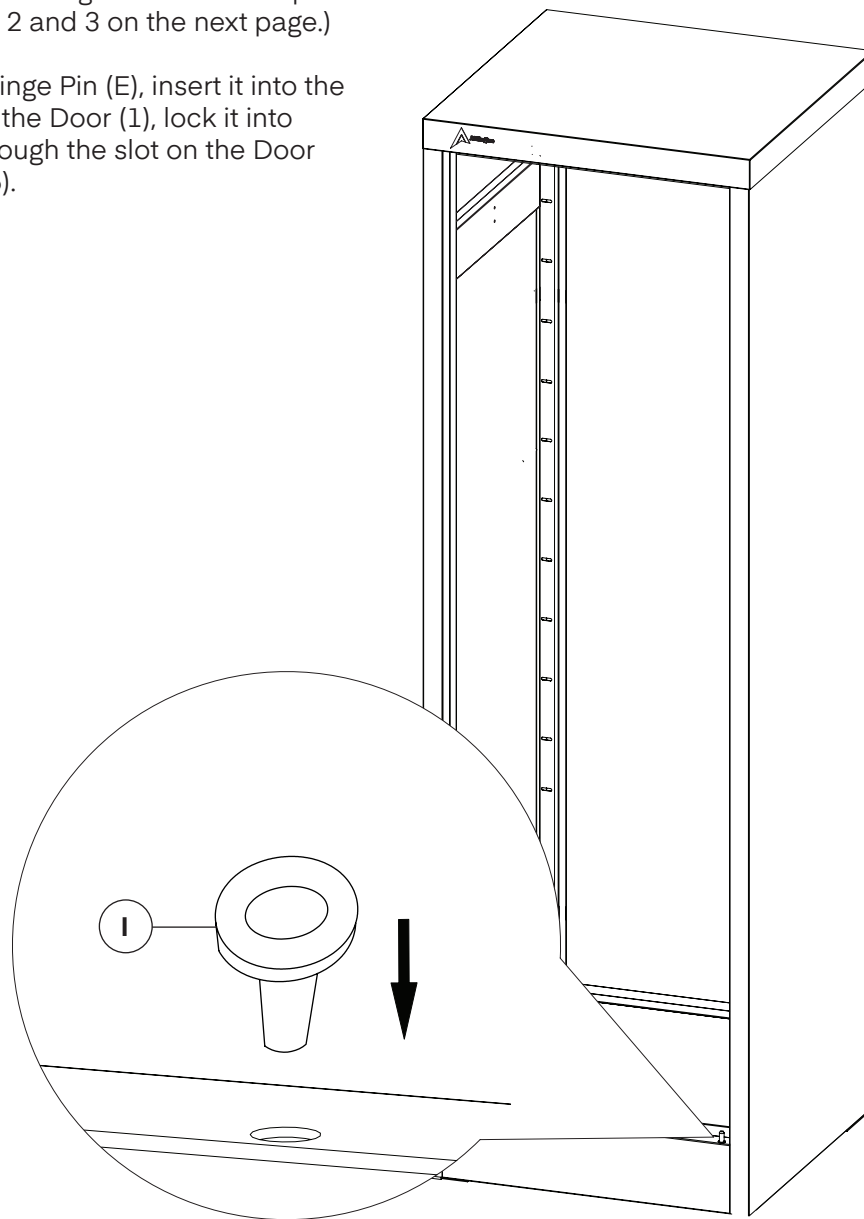

Assembly Instructions

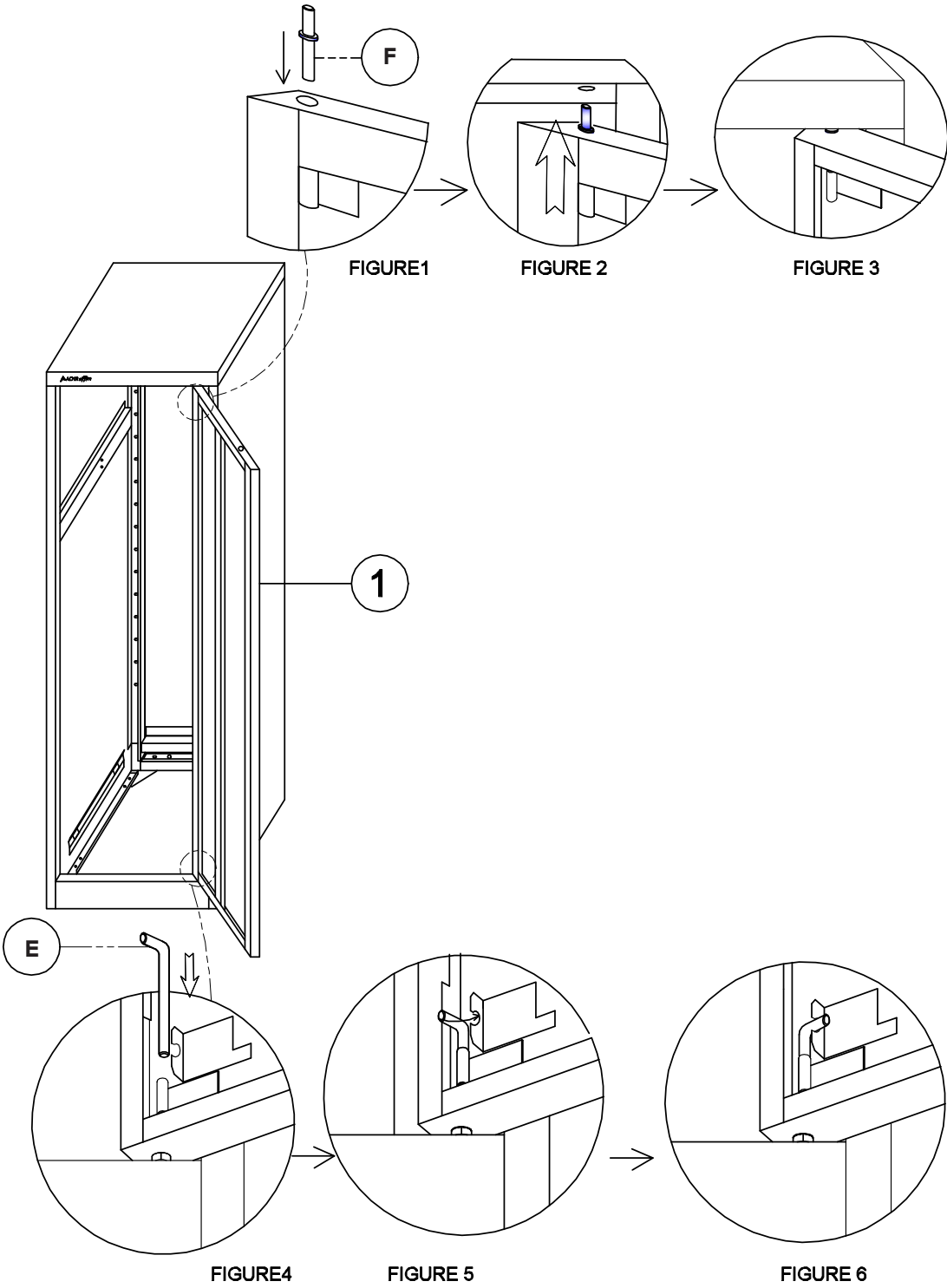

Assembly Instructions

STEP 5:

Insert the Base (8) into the locker by pressing down with edges pointing down and the smooth side up.

STEP 6:

Attach the Double Hook (A) with the Small Screws (C).

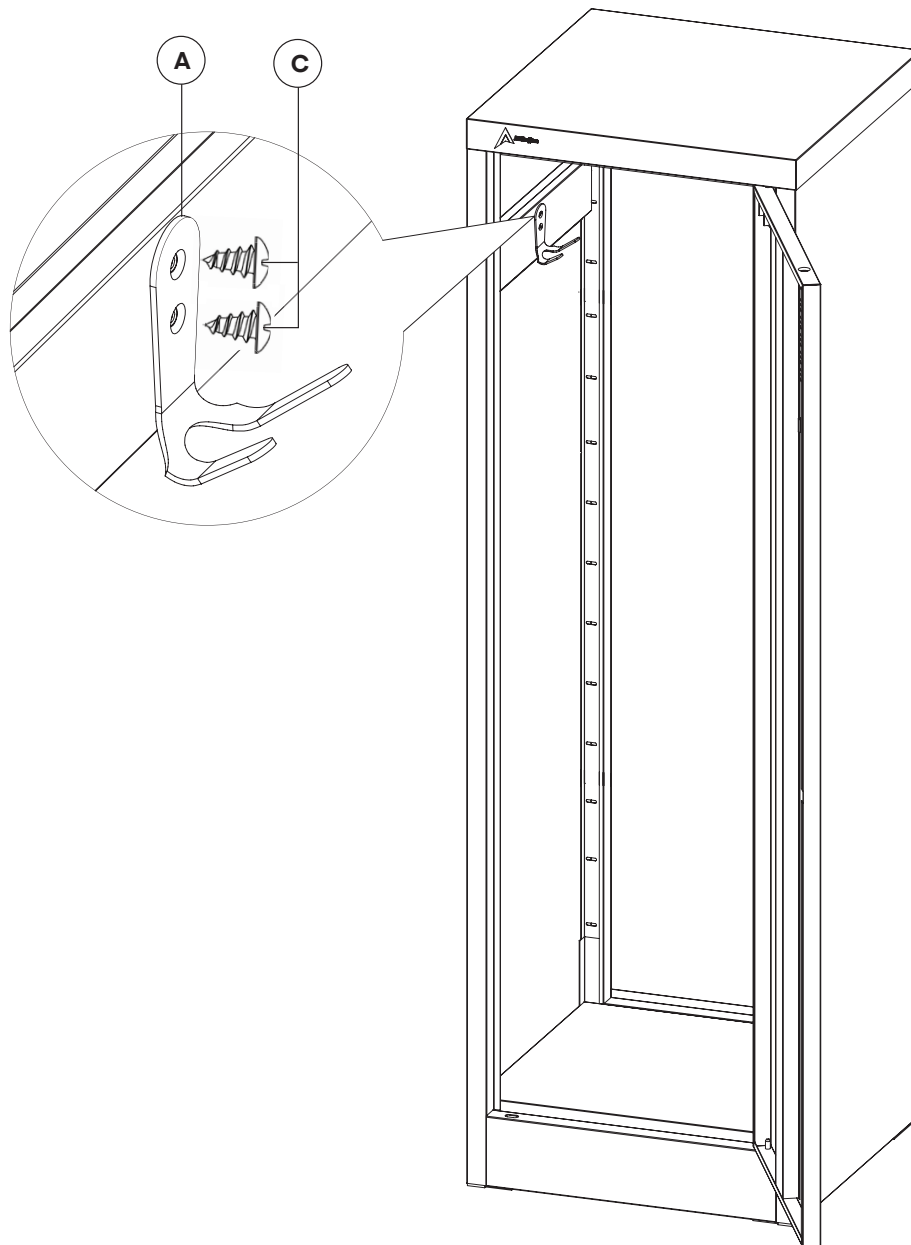

Assembly Instructions

STEP 7:

Insert the two Rubber Buffer's (H) in the top and bottom corners of the Door (1), as shown.

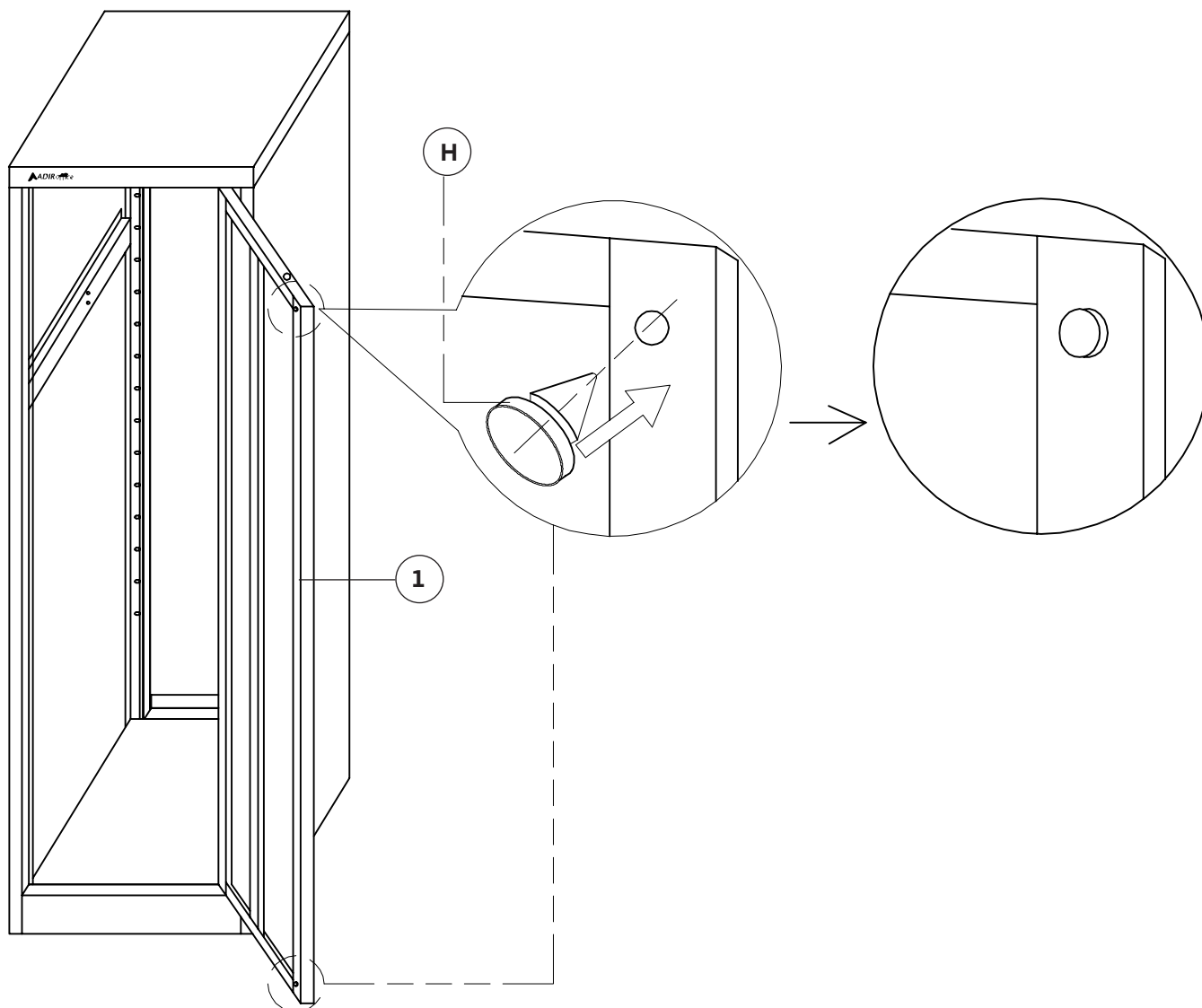

Mounting Instructions

STEP 1:

- A. There are two holes near the top of the Back Panel (3) of your locker.
- B. Place your locker where you want to install it, and using a pencil, mark the location of each hole on the wall.
- C. In the marked locations, drill a hole large enough for the Wall Anchor Screws (G).
- D. Using a Phillips head screwdriver, twist each of the Wall Anchor Screws (G) through the back of the locker and into the holes in the wall.
- E. Hand tighten each Wall Anchor Screw (G) as using a drill could damage the hole.

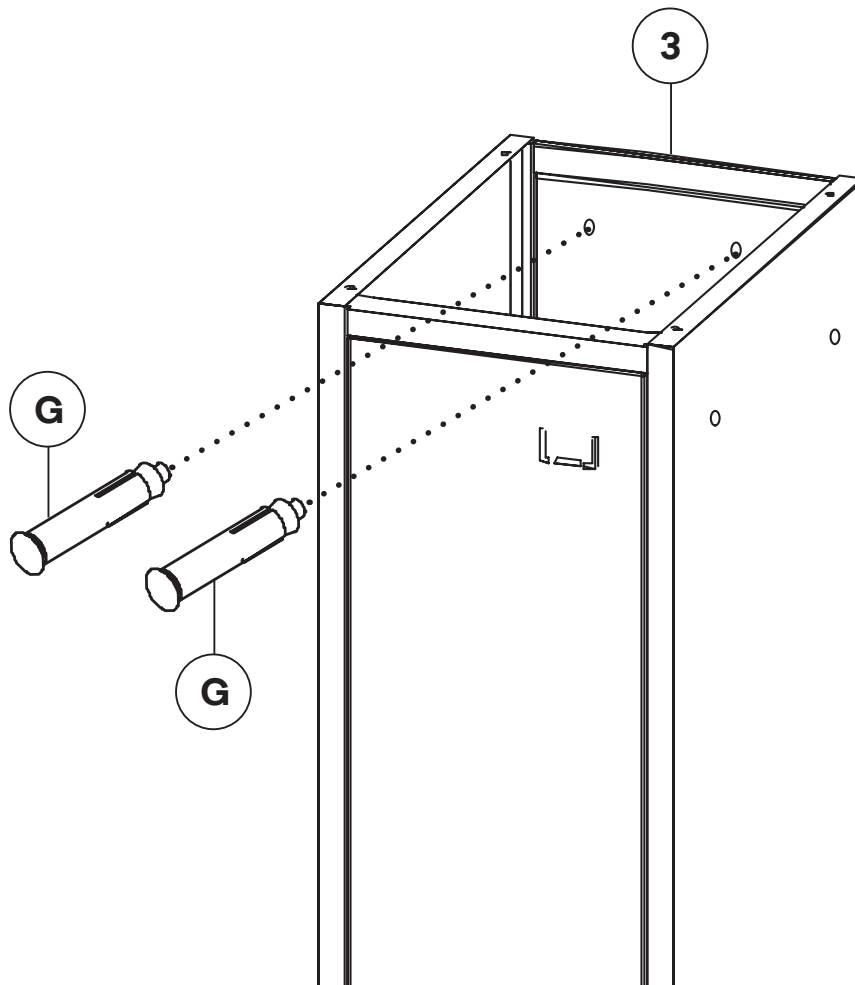

Limited Warranty

1. AdirCorp (the company) warrants to the purchaser that the product will be free from defects in workmanship and materials for a period of one (1) year from the date of purchase.
2. These warranties are not assignable or transferable to any other person.
3. Any damage to the product as a result of misuse, tampering, abuse, neglect, accident, improper installation, modification, unauthorized service, destruction, or the alteration of the serial number, or use violate of the instructions furnished by the Company will void this warranty.
4. The sole responsibility of the Company shall be limited to the repair or replacement (in its sole discretion) of any component of the product which fails to conform to this warranty at no cost to the purchaser for the period of the warranty.
5. Contact the Company directly to obtain service under this warranty. If it becomes applicable to send a defective product to the Company, a Return Authorization Number must first be obtained from the company. In order to obtain service under this warranty, purchaser must provide the Company with the following items (a) proof of purchase, (b) police or fire department report, (c) photographs of damaged sad, and (d) written testimonial.
6. Products shipped without prior Return Authorization and Return Authorization Number may not be accepted, and the Company will not be responsible for their disposition and/or cost of return to the owner.
7. The Company will not assume any responsibility for any loss or damage incurred in shipping. All return authorized products should include a copy of the original invoice in order that this warranty may be Honored.
8. This warranty is not an insurance policy. The Company is not responsible for any manner of damage to or theft of the Purchaser's product or its contents.
9. We recommend that the product being returned is accompanied by the sales receipt with all relevant information regarding the purchase of the item and is returned to the Company within ten (10) days of the claim date of purchase to validate this warranty.
10. Any implied warranties that the purchaser may have are limited to the duration of the warranties described above. There are no further warranties that extend or apply beyond the face hereof, and the company expressly disclaims and excludes any and all warranties of merchantability or fitness for a particular purpose. Some states do not allow limitations on how long an implied warranty lasts, so the above limitation may not apply to you.
11. Repair or replacement shall be the sole remedy for the purchaser under this warranty. The company shall not be liable for any direct, indirect, incidental or consequential damages, losses or expense arising from the use or misuse of the product. Some states do not allow the exclusion or limitations of incidental or consequential damages, so the limitation may not apply to you.
12. This warranty gives you specific legal rights, and you may also have other rights which vary from state to state.

Disclaimer

By purchasing products from AdirCorp, user agrees as follows:

TO THE MAXIMUM EXTENT PERMITTED BY LAW, THE PRODUCTS AND INFORMATION ON THIS SITE IS PROVIDED "AS IS" AND WITH ALL FAULTS AND ADIRCORP. MAKES NO PROMISES, REPRESENTATIONS, OR WARRANTIES, EITHER EXPRESS, IMPLIED, STATUTORY, OR OTHERWISE, WITH RESPECT TO THE PRODUCTS AND INFORMATION, INCLUDING ITS CONDITION, ITS CONFORMITY TO ANY REPRESENTATION OR DESCRIPTION, OR THE EXISTENCE OF ANY LATENT OR PATENT DEFECTS, AND ADIRCORP. SPECIFICALLY DISCLAIMS ALL IMPLIED (IF ANY) WARRANTIES OF TITLE, MERCHANTABILITY, NON INFRINGEMENT, FITNESS FOR A PARTICULAR PURPOSE, ACCURACY OR COMPLETENESS, QUIET ENJOYMENT, AND QUIET POSSESSION. THE ENTIRE RISK ARISING OUT OF USE OR PERFORMANCE OF THE PRODUCTS AND INFORMATION LIES WITH USER.

TO THE MAXIMUM EXTENT PERMITTED BY LAW, IN NO EVENT SHALL ADIRCORP PRODUCTS OR ITS SUPPLIERS BE LIABLE FOR CONSEQUENTIAL, INCIDENTAL, SPECIAL, INDIRECT, OR EXEMPLARY DAMAGES WHATSOEVER ARISING OUT OF OR IN ANY WAY RELATING TO THIS AGREEMENT OR USER'S USE OF OR INABILITY TO USE THE PRODUCTS AND INFORMATION, OR THE PROVISION OR FAILURE TO PROVIDE SUPPORT SERVICES, INCLUDING, BUT NOT LIMITED TO, LOST PROFITS, LOSS OF CONFIDENTIAL OR OTHER INFORMATION, BUSINESS INTERRUPTION, PERSONAL INJURY, LOSS OF PRIVACY, FAILURE TO MEET ANY DUTY (INCLUDING OF GOOD FAITH OR REASONABLE CARE), NEGLIGENCE, COSTS OF PROCUREMENT OF SUBSTITUTE GOODS OR SERVICES, OR ANY OTHER CLAIM FOR PECUNIARY OR OTHER LOSS WHATSOEVER, OR FOR ANY CLAIM OR DEMAND AGAINST USER BY ANY OTHER PARTY, EVEN IF ADIRCORP HAS BEEN ADVISED OF THE POSSIBILITY OF SUCH DAMAGES. THESE LIMITATIONS SHALL APPLY NOTWITHSTANDING ANY FAILURE OF ESSENTIAL PURPOSE OF ANY LIMITED REMEDY.

NOTWITHSTANDING ANY DAMAGES USER MAY INCUR FOR ANY REASON WHATSOEVER (INCLUDING, WITHOUT LIMITATION, ALL DAMAGES REFERENCED ABOVE AND ALL DIRECT OR GENERAL DAMAGES), THE ENTIRE LIABILITY OF ADIRCORP AND ANY OF ITS SUPPLIERS UNDER ANY PROVISION OF THIS AGREEMENT AND YOUR EXCLUSIVE REMEDY FOR ALL OF THE FOREGOING SHALL BE LIMITED TO THE GREATER OF THE AMOUNT ACTUALLY PAID FOR THE PRODUCTS AND INFORMATION OR U.S. \$1. THE FOREGOING LIMITATIONS, EXCLUSIONS, AND DISCLAIMERS SHALL APPLY TO THE MAXIMUM EXTENT PERMITTED BY APPLICABLE LAW, EVEN IF ANY REMEDY FAILS ITS ESSENTIAL PURPOSE.

If any provision of this Agreement is declared invalid or unenforceable, the remaining provisions of this Agreement will remain in effect. AdirCorp has the right to modify these terms and conditions at any time.



Item Number: ADI629-02-SERIES

64 Mountainview Blvd. • Wayne, NJ • 07470 • ©2021 All Rights Reserved.

adircorp.com