

ASSEMBLY INSTRUCTIONS

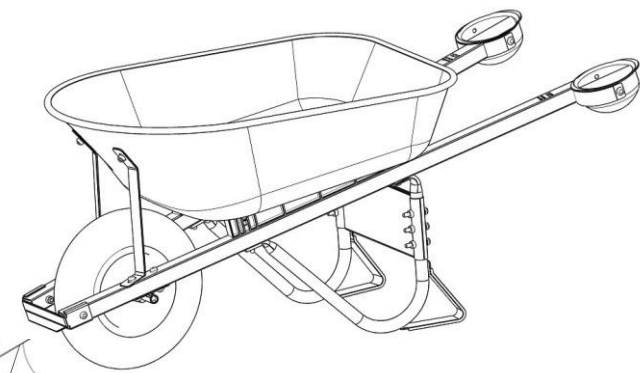

PIVOT-ALL Wheelbarrow HDX

<https://pivot-allmotiontools.com/>

Read all instructions prior to assembly.
Tools Required:
 13mm wrench or 13mm deep-drive socket
WARNING:
 Tire is not for highway service.

1 Push Bolts (M & N) through bottom of Tub (D) and through Riser (B). Repeat for second Riser.

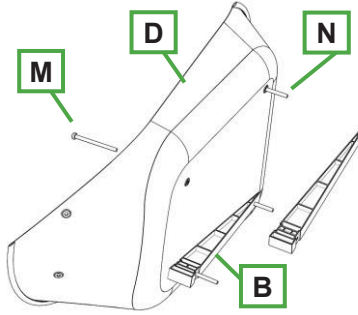

5 Use two Bolts (O) and two Nuts (Q) to attach Wheel Guard (C) to front of Handles.

Bolts should point to the inside of the Handles. Use a 13mm wrench or socket to fully tighten Wheel Guard. Leave the rest of the nuts and bolts loosely fastened.

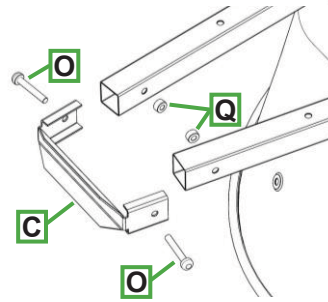

2 Turn Tub over and place Handles (A) over Bolts and lower onto Risers. **NOTE:** Offset Handle cups outward.

Place Cross Braces (K & L) over Bolts.

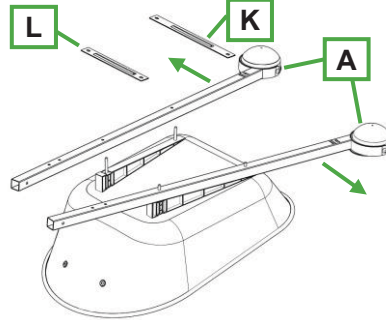

6 Attach Axle Bracket (E) to bottom of Handle using a Bolt (O) pushed through the hole closest to Tub. Push second Bolt (O) through hole in bottom of Tub Brace (I) then through Handle (using hole closest to Wheel Guard) and finally through Axle Bracket. Attach loosely with Nuts (Q).

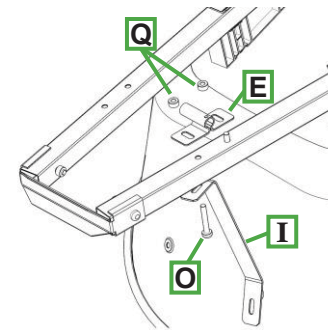

3 Make sure the holes in Leg (J) are facing the back of the Tray and then place Leg over Bolts and loosely attach to Handle with Nuts (Q). Repeat for other Leg.

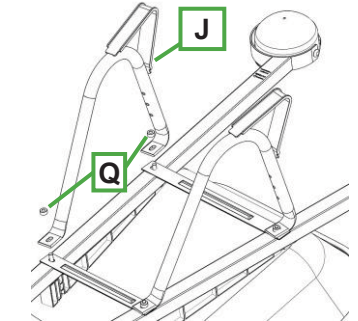

7 Slide Axle (F) through Wheel (G) and then into attached bracket. Then slide second Axle Bracket (E) over other end of Axle. Loosely attach second Axle Bracket and second Tub Brace to Handle.

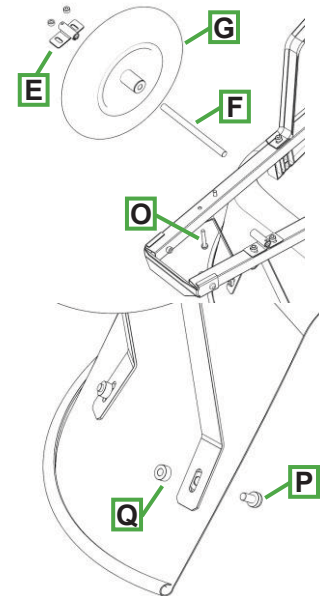

Use Bolts (P) and Nuts (Q) to attach tops of Tub Braces to Tub.

Use a 13mm wrench or socket to fully tighten all nuts.

Please spray wheel gears with WD40 before first use and as needed.

4 Place Leg Braces (H) across back of Leg and loosely attach using three Bolts (R) and Nuts (Q). Repeat to attach the other end of the Leg Braces to other Leg.

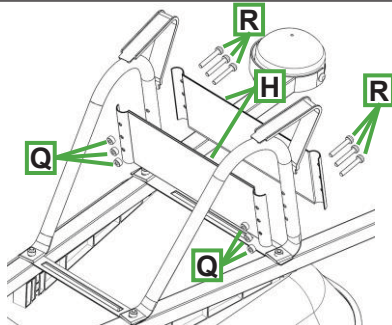

Packaging Contents

A -Handles X2 	B -Riser X2 	C -Wheel Guard X1
D -Tub X1 	E -Axle Bracket X2 	F -Axle X1
G -Wheel X1 	H -Leg Brace X2 	I -Tub Brace X2
J -Leg X2 	K -Cross Brace Long X1 	L -Cross Brace Short X1

Hardware Contents

M -M8*120 Bolt X2 	P -M8*19 Bolt X2
N -M8*70 Bolt X2 	Q -M8 Nut X18
O -M8*55 Bolt X6 	R -M8*40 Bolt X6