

Tools Needed	3
Important Information	4
Substrate Preparation	5
Installation Instructions	7

Questions, problems, missing parts? Before returning to your retailer, contact our STAINMASTER Support Team at 800-438-7668.

TOOLS REQUIRED FOR INSTALLATION



- A. Knee Pads
- B. Safety Glasses
- C. Cut-Resistant Safety Gloves
- D. HEPA-Filtered Vacuum
- E. Dust Mask
- F. 2 lb. (~32 oz.) Dead Blow Hammer (preferred) or Rubber Mallet
- G. Oscillating Multi-Tool or Jamb Saw (for door jambs)
- H. Jigsaw with Carbide Blades (for complicated cuts)
- I. Chalk Line
- J. Pencil
- K. Speed Square
- L. Tape Measure
- M. Utility Knife with Blades
- N. Wedge Spacers or similar
- O. Pull Bar
- P. 6-foot and 1-foot Straight Edge or Level
- Q. Hand Roller

IMPORTANT INFORMATION

General Information & Limitations

Please watch the installation videos available at [Lowes.com](https://www.lowes.com). This flooring has a High Density Core (HDC) and is designed to be installed indoors only as a “floating floor” for residential applications. The optimal operating temperature is between 45°F to 115°F (7°C to 46°C). Avoid prolonged exposure to direct sunlight or other heat sources where temperatures will exceed 90°F (32°C), as damage may occur. This product is not suitable for heavy rolling loads. Rolling chairs with soft or W-type casters and a maximum rolling weight of 250 lbs. are acceptable, provided that a polycarbonate chair mat is used to protect the flooring in rolling chair areas. Do not secure flooring or furniture to the subfloor with mechanical fasteners or adhesives. Do not install cabinets, kitchen islands, or other non-movable furniture on top of this floor covering. If required or concerned, immediately contact the STAINMASTER Support Team at 800-438-7668.

Warning

All local, state, and federal regulations must be followed; this includes the removal of in-place asbestos (floor covering and adhesive) and any lead-containing material. The Occupational Safety and Health Administration (OSHA) has exposure limits for people exposed to respirable crystalline silica; this requirement must be followed. Do not use solvent or citrus-based adhesive removers. When appropriate, follow the Resilient Floor Covering Institute’s (RFCI) Recommended Work Practice for Removal of Existing Floor Covering and Adhesive. Always wear safety glasses and use respiratory protection or other safeguards to avoid inhaling any dust. The label, installation, and maintenance instructions along with the technical data sheet, limited warranty and any appropriate Safety Data Sheet (SDS) of all products must be read, understood, and followed before installation commences. If the substrate or subfloor fails for any reason, then the floor covering limited warranty is void.

Site Conditions & Storage

The prepared installation area must be fully enclosed and weather tight. During the installation, any direct sunlight should be blocked using blinds, drapes or other protection. The ambient temperature during installation must be > 60°F (16°C), with a recommended maximum of 80°F (27°C).

Note: When installing at temperatures > 80°F (27°C), the size of an expansion gap will increase when the floor covering is cooled.

Documentation

Record and file the measured and observed site conditions and test results, including all photographs and corrective measures. Maintaining this documentation, along with the original invoice and any labor receipts throughout the warranty period, is recommended, as this will be required in the unlikely event of a claim.

SUBSTRATE PREPARATION

Flatness

Check all substrates for flatness prior to installation. The maximum acceptable tolerance is < 1/8-in. gap (2 x US quarters) over 6-ft. and \leq 1/16-in. gap (1 x US quarter) over 1-ft. Make any necessary adjustments to the substrate before installation. Dormant cracks, saw cut joints and grout lines < 1/8-in. wide or deep are acceptable – all others must be cleaned of all dirt and debris, then filled using a suitable commercial grade patching or repair compound, following the product instructions.

Concrete Substrates & Concrete Moisture

All concrete must be free of contaminants and structurally sound. If required, smooth the surface using a suitable, moisture-resistant commercial grade leveling or patching compound, following the product instructions. Do not install if hydrostatic pressure is visible, present or suspected. If a chemical adhesive remover has been used, contact the technical department.

For all on and below grade concrete slabs, test the surface to confirm it is absorbent (porous), following the ASTM F3191 Standard Practice for Field Determination of Substrate Water Absorption (Porosity) for Substrates to Receive Resilient Flooring. The water droplets placed on the substrate must be absorbed for it to be considered absorbent. If required, the concrete can be made porous by mechanical methods, such as diamond grinding, a DiamaBrush buffer attachment, shotblasting or similar.

If the substrate cannot be made porous and will not have a topical moisture mitigation system installed, install a \geq 6-mil thick polyethylene (PE) sheet, which is available at most home improvement stores. Use sheeting that is \leq 10-ft. wide to prevent wrinkles and folds. Sheeting must be installed over the entire area and extend at least 2-in. up the walls. All seams must be overlapped and sealed according to the product instructions.

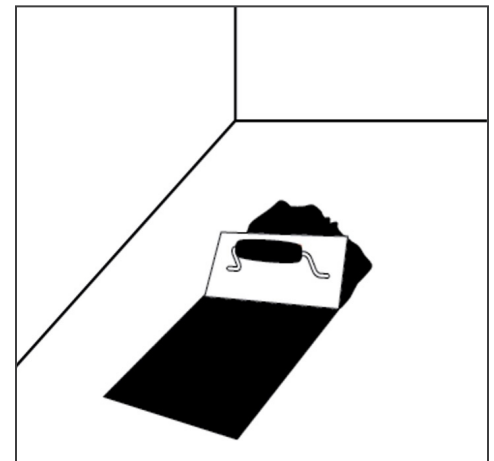
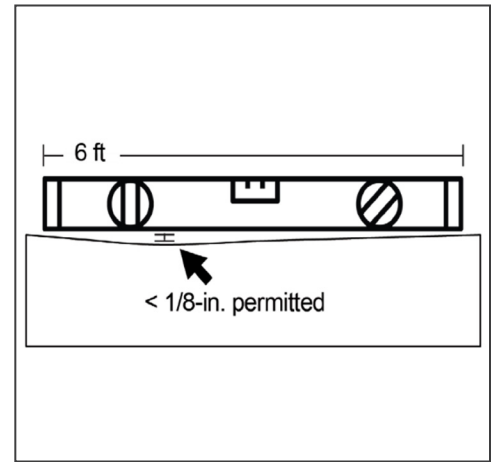

Wood Substrates

All wooden subfloors and substrates must be dry and in compliance with the moisture content percent (MC-%) for your region. Regional values are freely available by searching “moisture map of wood” images. Test using a non-destructive electronic moisture meter, following the product instructions. The subfloor must comply with local building codes, have at least 18-in. of well-ventilated air space below and have a suitable vapor retarder to isolate the subfloor from ground cover and outdoor conditions. Wood subfloors must have a total thickness of at least 1-in. Sleepers must not make direct contact with concrete or earth. If necessary, install an underlayment grade plywood with a minimum thickness of 1/4-in. on the surface. The underlayment must be installed in the opposite direction to the subfloor, following ASTM F1482 Standard Practice for Installation and Preparation of Panel Type Underlayments to Receive Resilient Flooring.

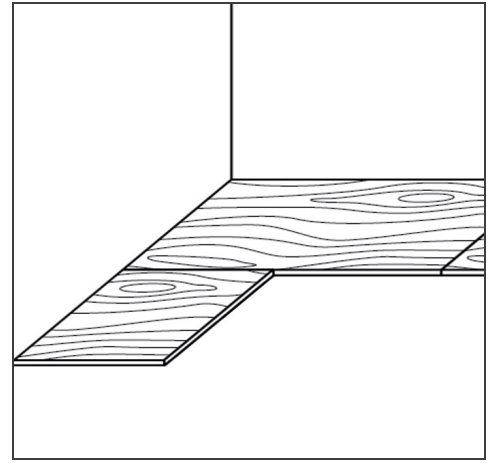

Note: plywood is a water-sensitive subfloor that may become damaged or deformed by topical liquids. To protect wood subfloors from topical water exposure, follow the Wet Area Guidelines below.

Radiant Heating Substrates

When installing floor covering over a substrate that contains a radiant heating system, ensure the radiant heat does not directly contact the floor covering and is set at the correct “in-service” temperature for 48-hours prior, during and after the installation. The radiant heat may be gradually increased or decreased to maintain the correct “in-service” site conditions.

Note: Ensure the temperature of the radiant heating system does not exceed 85°F (29°C).

Additional Acoustic Underlayments

Additional acoustic underlayments are not recommended or required. However, should one be used, ensure a polycarbonate chair mat is used in all rolling chair areas. Do not use additional acoustic underlayments in any commercial areas.

Unsuitable Substrates

These include but are not limited to: any floating or loose floor coverings, hardwood installed directly over concrete, carpet, cushion vinyl, rubber, cork, foam, asphalt tile, any additional acoustic underlayment, any substrate with visible mold, mildew, or fungi and any substrate in wet areas, such as inside showers and saunas. Do not install directly over any adhesive or adhesive residue of any kind. Do not install directly over radiant heating elements/pipes or in recreation vehicles, campers or boats.

Other Subfloors/Substrates

Installing over existing resilient vinyl flooring is not recommended. However, it may be possible over some materials, such as hardwood flooring, VCT, VAT, quartz tile, solid vinyl tile, sheet vinyl or linoleum, as well as existing hard surface flooring substrates, such as terrazzo, porcelain or ceramic tile. Ensure existing flooring is a single layer and is clean, dry, sound, solid and well adhered. All loose material must be removed and repaired or replaced. All grout lines and wide seams greater than 1/4-in. in width and/or depth, as well as any significant substrate imperfections, must be filled and troweled flush with a suitable cementitious patch.

Note: Existing hardwood floor coverings will swell when exposed to moisture – vinyl floor covering may restrict the movement of moisture in hardwood, which may result in flooring failure, especially when installed on or below grade. Some hardwood floor coverings may also discolor vinyl floor covering, which is excluded from warranty coverage. Electing to install over any existing floor covering releases the manufacturer from any responsibility regarding the suitability and continued performance of the product, including any resulting effect on the new floor covering.

Wet Area Guidelines

Some subfloors and substrates, such as plywood, may be sensitive to and damaged or deformed by topical liquids, such as water, pet urine and spills. While STAINMASTER Interlocking Flooring is a waterproof product, water-sensitive subfloors may require additional protection to prevent water exposure. When installing floor covering in wet areas, ensure that bathmats or similar are used where appropriate to decrease the amount of water that can collect on the surface. Any and all spills should be cleaned up immediately after discovering them and within 8 hours. Subfloor flatness is critical to preventing water migration through seams that may flex or peak due to foot traffic and subfloor deflection – be sure to check flatness and make all necessary adjustments prior to installing.

Water-sensitive substrate must have a \geq 6-mil thick polyethylene (PE) sheet (available at Lowe's) installed over the entire area and extend at least 2-in. up the walls. All seams must be overlapped and taped according to the product instructions. In addition, the area must be separated from all other rooms using a suitable water-resistant t-molding. Following flooring installation, the plastic sheet must be trimmed flush with the surface of the subfloor. Prior to installing wall base or molding, the required perimeter expansion gap must be filled with a 100% silicone caulk, including the wet area side of all t-moldings. Additionally, all door jambs, plumbing and vertical surfaces that won't have wall base or molding installed must be sealed with 100% silicone caulk. Once the entire perimeter has been filled or sealed, water-resistant wall base, moldings or other accessories may be installed. Apply a bead of silicone caulk to the parts of the wall base or moldings that will make contact with the surface of the flooring. Ensure all wall base and moldings are attached to the subfloor, wall or wall base without compression, to allow movement and cleanup any remaining silicone immediately. Do not anchor wall base or moldings into or through the floor covering.

INSTALLATION INSTRUCTIONS

Expansion Gap

If the length or width of the installation area is ≤ 50 -ft., an expansion gap of at least 3/8-in. must be created around the entire perimeter. If the overall length or width is between 50 - 85-ft., then the gap must be increased to 1/2-in. around the entire perimeter. A maximum of 85-ft. in length or width must not be exceeded. If required, use a suitable trim molding covering the edges by 1/8-in. and allowing a 1/2-in. expansion gap.

For three-season rooms, a gap of at least 1/2-in. around the entire perimeter is required. In addition, the area must be separated from all other rooms using a suitable trim molding. The maximum of 30-ft. in length or width must not be exceeded.

Note: Areas with very heavy furniture ≥ 800 -lb. (363-kg) must be isolated from the rest of the installation with a compatible t-molding and have $\geq 1/2$ -in. expansion gap.

General Installation Preparation

Remove any quarter round molding and/or wall base as needed. Undercut all wooden door jambs and the first inch of any remaining wall base (which will be covered with molding) with an Oscillating Multi-Tool or jamb saw – the height must be the thickness of the floor covering plus 1/64-in., which allows the floor covering to expand and contract freely, out of sight, with temperature fluctuations. Steel door jambs should be pattern-scribed, leaving the required expansion gap. Use a color-coordinated 100% silicone to fill the void. Clean the entire area to be installed using a HEPA-filtered vacuum.

Before beginning, check and make sure the lot numbers on the packaging match and mix the floor covering from several boxes to ensure a random appearance. During the installation, inspect for visible defects, including any damage, gloss, color or shade variations, dirt and debris in the locking mechanism (remove using a soft brush), as installing it assumes full responsibility. If you have any concerns, do not install and immediately contact the STAINMASTER Support Team at 800-438-7668.

Layout

Follow the design or drawings provided or agreed upon by the designer, architect, or end-user. The end joint layout for all planks should be random – make sure joints are not “stair stepped”. Failure to randomize end joints could weaken the integrity of the joint system, which may lead to failure. All planks must be at least 8-in. in length and all end seams must staggered by ≥ 8 -in. Tiles must be installed in a brick-bond pattern, offset by 1/2 or 1/3 of the plank.

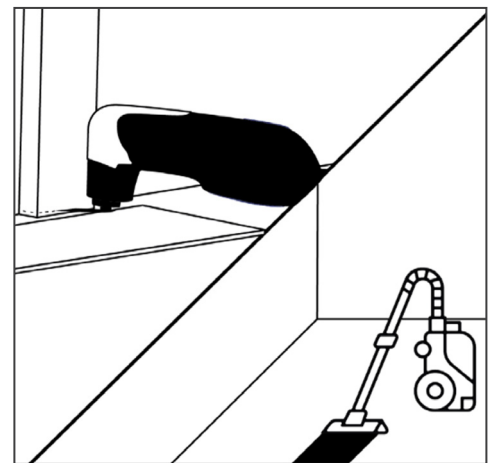

Cutting

To cut the floor covering, measure and mark the surface with a pencil, then carefully score the surface a few times on the mark using a sharp utility knife along the side of a speed square. Snap the plank downwards and complete by cutting the backing from underneath. For complicated cuts, such as door jambs, it is recommended to use a jigsaw with a carbide blade following the product safety instructions.

Room Preparation

Clean the entire area to be installed twice using a HEPA-filtered vacuum. Determine the best wall to start installation on – typically this would be the longest straight wall with a doorway (if present). Measure the width of the room and, allowing for two expansion gaps, calculate the width of your last row. If it is less than half the width of the floor covering, or if a balanced design is required, then reduce the width of the first row accordingly. Use a chalk-line to mark the outside edge of the first row on the substrate. If needed, trim the first row (the side without the extended locking mechanism) to fit, accounting for the expansion gap.

Click Installation

The first plank (#1) of the first row should be a full-length plank. Trim off the profiles facing the wall and position the cut edges adjacent to the wall making sure that you leave an expansion gap of 3/8-inch (10 mm) between the plank and wall, using spacers as needed. The entire installation requires a 3/8-inch expansion space.

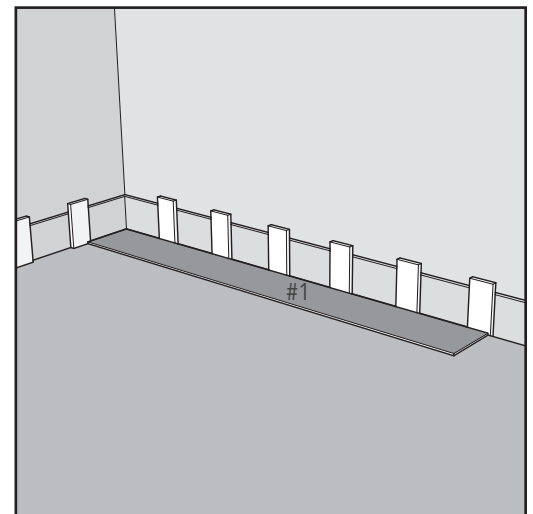
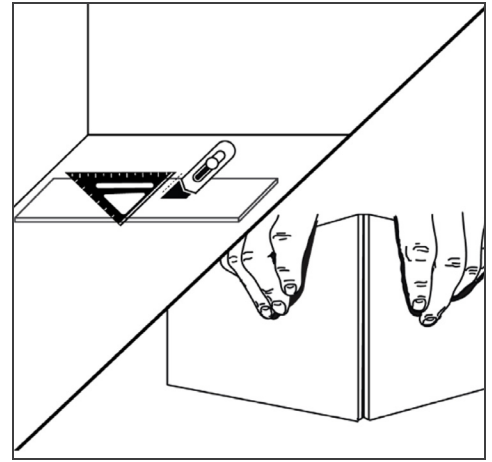

The first plank (#2) of the second row should not exceed 50% of the length of the plank.

Align the first plank (#2) of the second row with the first plank (#1) of the first row at an angle and engage the long side joint by folding down until joints lock. The factory end should face in from the perimeter of the installation. Cut edges always face away from the field of the installation. If necessary, to properly seal the joint, use a small scrap of plank/tile to tap along the entire length of the plank/tile. Lock the scrap piece – groove to tongue or tongue to groove – to the plank/tile requiring tightening and lightly tap the edge of the scrap with a tapping block. This will bring the tile edges tight together.

Place the short side edge second plank (#3) of the first row against the short side end joint of plank (#1) of the first row. Lock the short side edge joints by pressing down with your hand or a small hand roller. If necessary, gently tap on top of the plank with a tapping block or scrap piece of flooring until joint is locked. Do not hammer directly on the plank.

Align the second plank (#4) of the second row against the long side joint of planks (#1 & #3) of the first row. Slide the plank so that the end joints are aligned. Rotate downward on the plank until the joint locks. If necessary, gently tap the long side closed. Lock the short edge joints by pressing down with your hand or a small hand roller. If necessary, gently tap on top of the plank with a tapping block or scrap piece of flooring until joint is locked. Do not hammer directly on the plank.

Place the short side edge third plank (#5) of the first row against the short side end joint of plank (#3) of the first row. Lock the short side edge joints by pressing down with your hand or small hand roller.

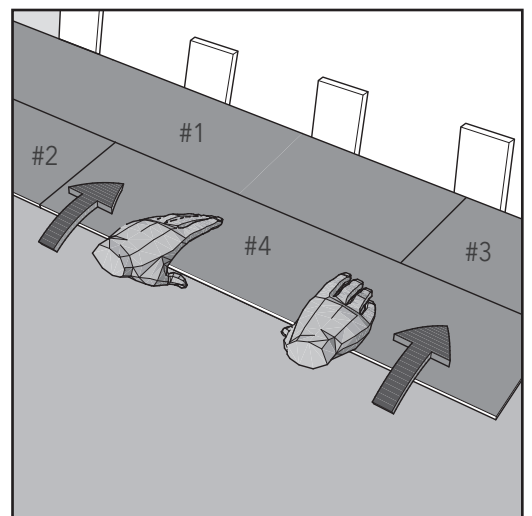
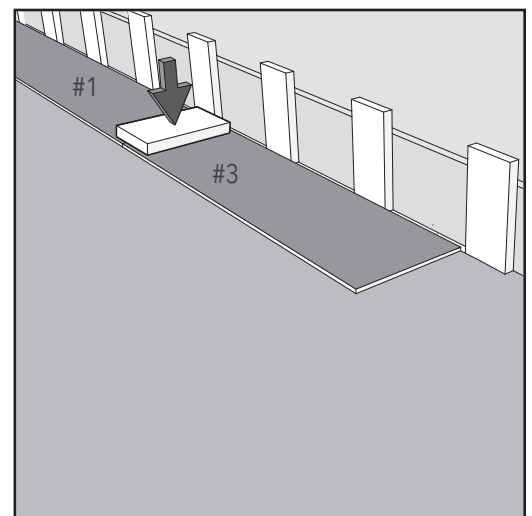
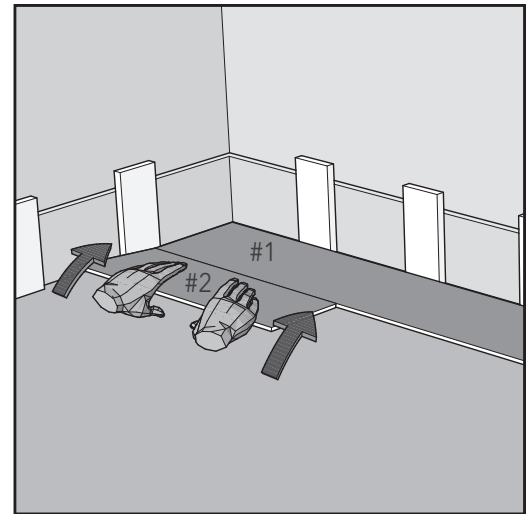

Align the third plank (#6) of the second row against the long side joint of planks (#3 & #5) of the first row. Slide the plank so that the end joints are aligned. Rotate downward on the plank until the joint locks. If necessary, gently tap the long side closed. Lock the short edge joints by pressing down with your hand or a small hand roller.

Align the fourth plank (#7) of the second row against the long side joint of plank (#5) of the first row. Slide the plank so that the end joints are aligned. Rotate downward on the plank until the joint locks. If necessary, gently tap the long side closed. Lock the short edge joints by pressing down with your hand or a small hand roller.

After each row is complete ensure, there is gap no less than 3/8-inch (10 mm) around the perimeter.

NOTE: Check floor squareness and straightness regularly.

Repeat these steps to complete the installation.

Please contact STAINMASTER Support Team at 800-438-7668 with any questions.

To install the final row of planks/tiles, you will usually need to cut them. We recommend the following: lay a plank face up on top of the last row installed with the tongue and groove facing the same way as the field of the installation (This will represent your final row to be trimmed). Place another plank against the edge of the wall and on top of the final row. Mark the plank underneath. Cut the plank and install the last row leaving ample expansion space.

Using a pull bar, place the wide end of the bar against the last plank and gently tap short end of the bar to engage the last row.

NOTE: In place of a resilient tile cutter, a miter or circular saw (with the blade cutting into the design of the plank) can be used to cut the flexible luxury vinyl flooring. A utility knife can also be used, scoring the top of the pattern and snapping the plank. It will be necessary to cut the foam underlayment after snapping the plank.

NOTE: Maintain a 3/8-inch (10 mm) expansion space around all walls and vertical objects. Quarter round or baseboard molding will cover this expansion space.

NOTE: Maintain the 3/8-inch space around cabinets, pipes, toilet flanges and any obstacle in the floor. (It is not recommended to trim around a toilet, however leave the expansion space around the toilet flange).

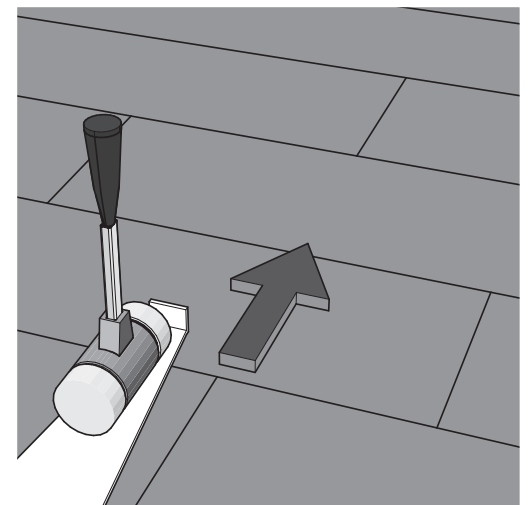
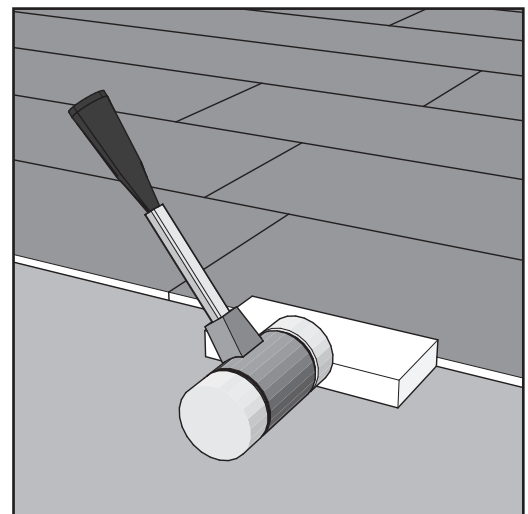
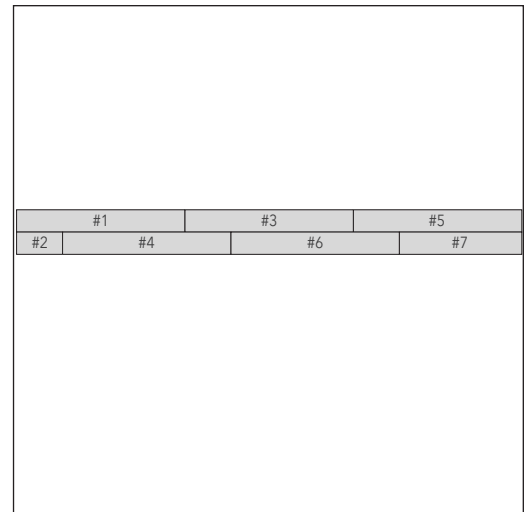

ADDITIONAL INSTRUCTIONS/NOTES

Multi-Width Plank Installation

To install the multi-width product, install a row of the 7 inch wide plank alternating between the 5 inch and 9 inch plank sizes. Install a 5 inch row, then 7 inch row, then 9 inch row, and then 7 inch row again, and then repeat this pattern.

Molding and Transitions

All floor molding and transition strips need to provide a 3/8-inch (10 mm) expansion space to allow expansion and contraction.

Ensure moldings and transitions strips will not pinch the flooring. This will prevent the floor from properly expanding and contracting as well as allowing the structure to move freely over the floor.

For rooms that have a run greater than 50 feet, a transition strip must be installed.

Never allow nails or screws to enter the rigid luxury vinyl flooring or the expansion zone around the flooring perimeter as it will prevent proper expansion and contraction of the structure and flooring.

Quarter round, base board, doorjamb, etc., should never pinch the flooring. This will prevent the floor from properly expanding and contracting as well as allowing the structure to move freely over the floor.

Treads, Risers and Ramps

Glue down method is required on all treads, risers and wheelchair ramps, using manufacturer-approved pressure sensitive adhesive. Apply the adhesive following the manufacturer's instructions. Install the riser after installing the tread. Install stair nose moldings afterward to protect the edge of the LVT.

Plank Replacement

Should one of your planks/tiles become damaged and need to be replaced, follow these simple instructions:

- Score top of damaged plank/tile with a utility knife. Make two triangle cuts near the end joint and then connect the points with one long cut in the middle of the plank/tile.

Pro-Tips

Do not hit the locking mechanism directly with any hammer. Use a tapping block and mallet to close any gaps. (Using a hammer will damage the locking mechanism and may result in peaking, gapping or broken joints.) If required, use a ~ 6-in. piece of scrap floor covering, seated in the locking mechanism, to lightly tap and close any joints.

If you need to install small cuts of floor covering that are < 3-in. in length or width, place a thin bead of liquid super-glue on the previously installed locking mechanism just before installing. This will ensure the pieces remain locked together during use. Do not get the adhesive on the surface – coverage will be ~ 30 ft. per oz.

After the first five or six rows are completed, turn around and continue installing, working on top of the installed material. This will allow the side joints to be pulled together rather than pushed together, which will make the installation even easier.

If you need to disengage the end joints for any reason, first unlock the side joints by lifting the outside edge of the row to ~ 25° and disconnect the entire row. Make sure all pieces are lying flat and are properly engaged (tap to engage, if required), then simply slide them apart. If they are angled or pulled upwards, the joint will break.

Completion

If used, plastic sheeting must be trimmed flush with the surface of the floor covering. If installed in a wet area, plastic sheeting must be trimmed flush with the subfloor. When installing in wet areas, ensure the expansion gap and all vertical surfaces are filled or sealed with a 100% silicone caulk and ensure all wall base and moldings are water resistant, following to the Wet Area Guidelines. Install all necessary wall base and/or moldings and ensure they are anchored to the substrate, wall or wall base without compression, to allow movement. Do not anchor wall base or moldings into or through the floor covering.

Protection

If required, protect the clean floor covering from other trades or heavy loads using ½-in. plywood or similar and tape all seams. For light traffic, use Ram board or similar and tape all seams. For furniture, use only polyurethane, silicon or felt glides (replaced > 3-times a year), keeping them clean and grit-free – all glides should be ≥ 1-2 in., especially on heavy furniture. Use protective polycarbonate chair mats designed for resilient flooring underneath rolling chairs or soft “W-type” wheels. Use non-rubber-backed entrance matting at all outdoor entrances, as this will improve air quality and reduce maintenance. Do not drag heavy or sharp objects directly across the surface – use hard surface “sliders” (available at Lowe’s). For areas that may be subjected to standing water on the surface, such as bathrooms with a bath or shower, the perimeter of the installation must be properly sealed using a 100% silicon caulk to prevent water from getting beneath the flooring. To avoid excessive fading or discoloration from direct sunlight exposure, use appropriate window treatments, an effective UV/IR film or Low-E glass windows. Take photographs and have any required documentation signed and filed following completion.

