



MERCER VI

72" x 36" Skirted Acrylic Whirlpool

Model Number
 3672MWSR-WH
 3672MWSL-WH
 RH & LH Drain White Whirlpool
 3672MWSR-BI
 3672MWSL-BI
 RH & LH Drain Biscuit Whirlpool

Features

- Color-matched jet trim & Pillow included
- 10 Self draining, adjustable hydrotherapy jets
- 3-Speed control for the 13 Amp pump
- Constructed of high-gloss durable acrylic
- Pre-leveled base for easy installation
- Made in the USA



All dimensions are +/- 1/2" and subject to change without notice
Confirm specifications before installation

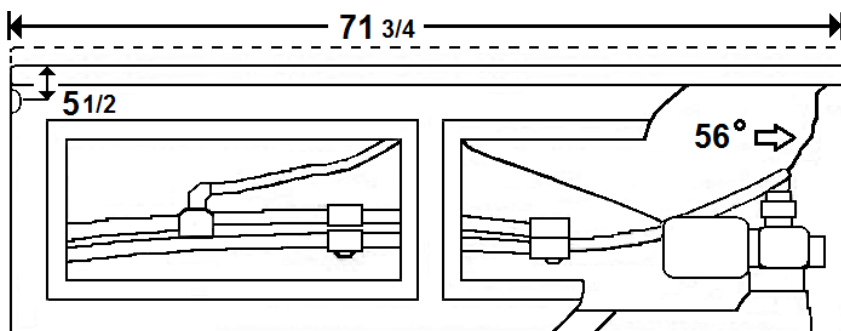
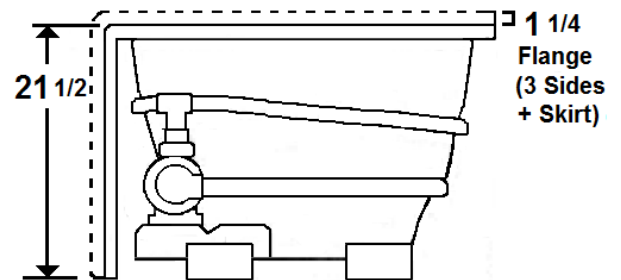
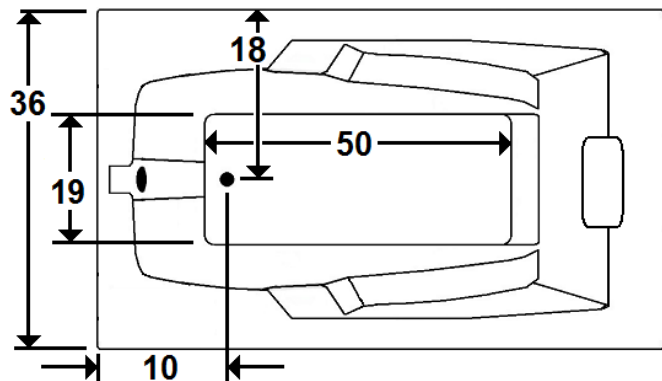

Standard (S) Pump Locations

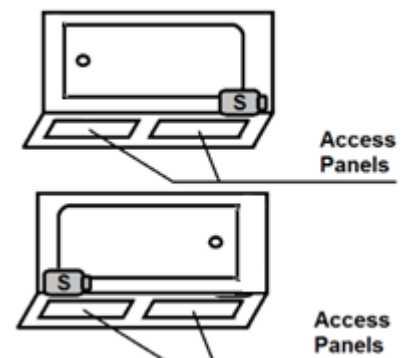

Technical Information

- Weight: 135 lbs.
- Water Depth to Overflow: 15 1/4"
- Water Operating Level: 51 gal.
- Water Capacity: 71 gal.
- Sump Dimension: 50" x 19"

Electrical Requirements.

- Standard Pump: 13 Amps
- Dedicated 20amp GFCI's required