

NOTICE

*Please make sure that you have all parts indicated and they are in good condition before you begin assembly of this item. Refer to part list and hardware list below for guidance.

*This item should be assembled on a soft surface to prevent scratching the finish during assembly.

*This item may require periodic tightening.

*If you are having difficulty, our friendly Customer Care team is always here to help. Please email customersupport@safavieh.com

PREPARATION

*Before beginning assembly of product, make sure all parts are present. Compare parts with part contents list and hardware contents list.

*If any part is missing or damaged, do not attempt to assemble the product.

*Estimated Assembly Time: **10 minutes.**





*Tools Required for Assembly (included): **Allen Key**

CARE AND MAINTENANCE

PAPER MACHE CARE

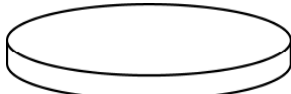
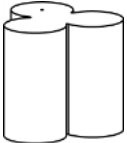
Store papier-mache furniture in a dry place away from direct sunlight, as moisture can weaken the structure and sunlight can fade the colors. Prevent spills and excessive humidity, as water can cause warping, swelling, or mold growth in papier-mache. Use a soft, dry cloth or a duster to gently remove dust and debris. If your papier-mache furniture needs cleaning, use a slightly damp cloth or sponge with mild soapy water. Avoid excessive water and never soak the furniture. After cleaning, make sure the furniture is completely dry to prevent moisture damage.

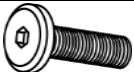
Part List and Hardware List

PIECE	DESCRIPTION	PICTURE	QUANTITY
A	Wooden TOP		1X
B	Paper Base		1X
C	MDF (disassemble out of the Wooden Top)		1X
HW1	WASHER		6x
HW2	BOLT M8x30		3X
HW3	BOLT M8x25		3X
HW4	ALLEN KEY		1X

 **SAFAVIEH**
FURNITURE

Model# : ACC3001

Product Dimensions: D18" x W18" x H22"

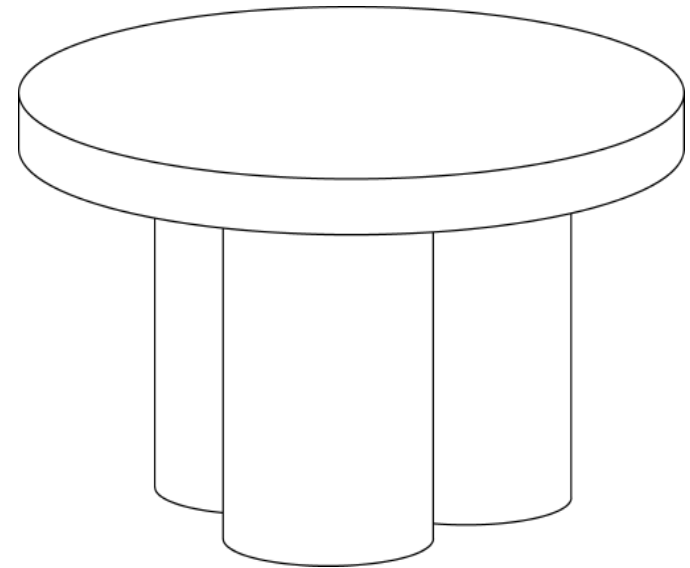

Weight Capacity - 44 LBS

Warning : Do not stand table

Warning : Do not over torque bolts

PREPARATION

*Before beginning assembly of product, make sure all parts are present. Compare parts with part contents list and hardware contents list.

*If any part is missing or damaged, do not attempt to assemble the product.

*Estimated Assembly Time: **10 minutes**.

*Tools Required for Assembly (included): **Allen Key**

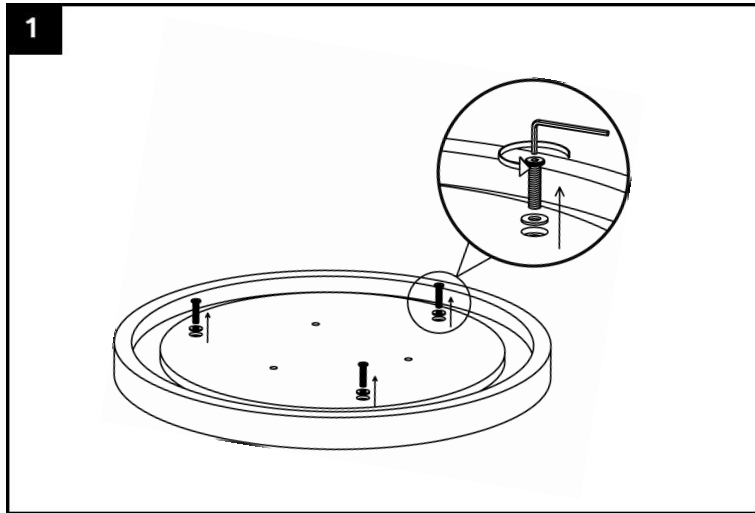

Step 1 : Remove the MDF inside the wooden top by using the allen key to open the Bolts and washer. Then start the next step

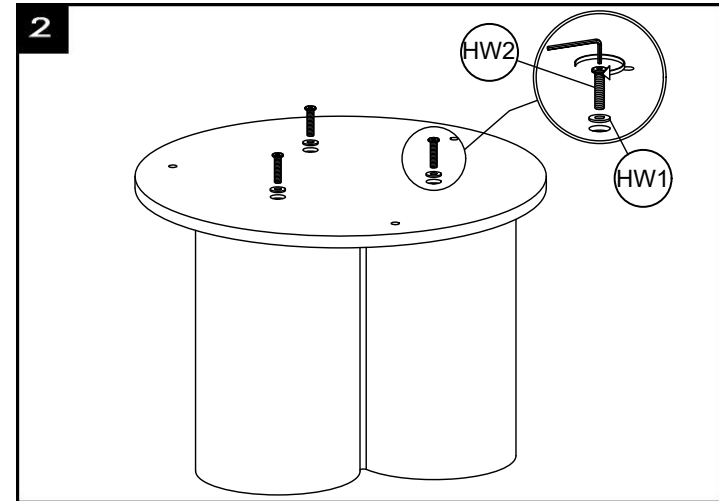

Step 2 : Use bolts M8x30 (HW2) and washer (HW1) to connect the MDF + Paper base

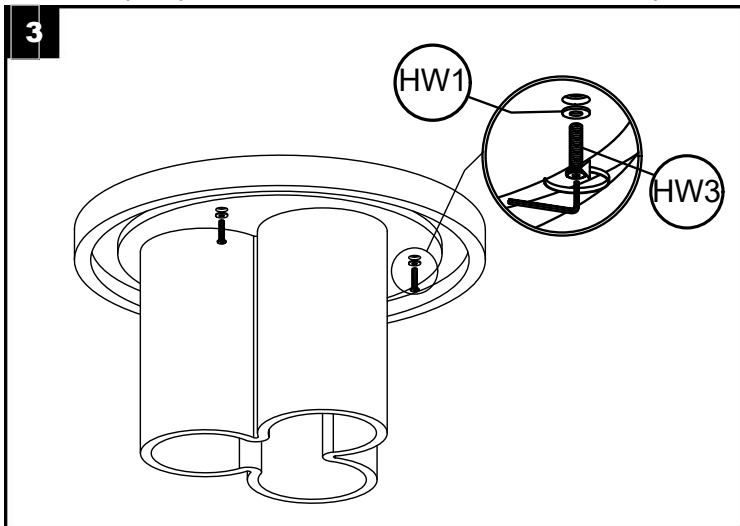

Step 3 : Use bolts M8x25 (HW3) and washer (HW1) to connect the MDF + wooden top

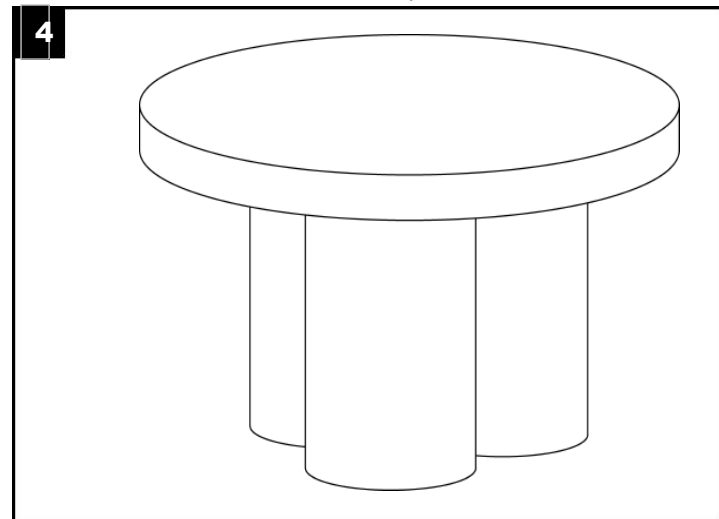

Step 3 : TURN AND FINISH