



OPERATOR'S MANUAL

MODEL: PP20WPK

Product No: A030010005

2 in. Semi-Trash Water Pump

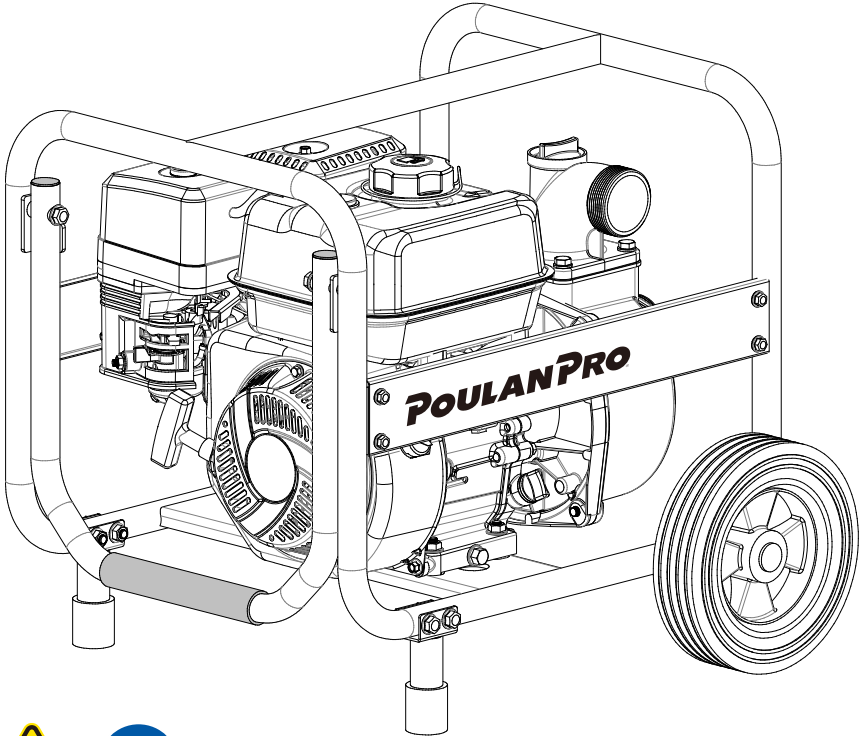

Have product questions or need technical support?

Contact Us:



Website: www.poulanpro.com



Toll free: 1-888-676-7909 Mon-Fri 8-4 CST



Email: support@poulanpro-power.us

Manufactured under license from Husqvarna AB
Poulan Pro is a registered Trademark of Husqvarna AB
Imported by Novus Performance Products.
W225N16708 Cedar Parl Ct. Jackson, WI



Vol. 2025-02

CONTENTS

Specifications 3

Introduction / Safety Definitions 4

Important Safety Instructions 5

Know Your Product 10

Assembly 12

Operation 14

Maintenance 18

Transportation and Storage 22

Troubleshooting 23

Basic Service Parts List 24

Warranty Statement 25

SPECIFICATIONS

PUMP	PP20WPK
Pump Type	Self-Priming Centrifugal
Intake Port Diameter	2 in. (50.8 mm)
Discharge Port Diameter	
Port Connection Type	NPT
Max Flow Rate	141 Gal/Min (533.74 L/Min)
Maximum Overhead Lift	100 ft (30.48 m)
Maximum Suction Lift	23 ft (7.0 m)
Impeller Material	Cast Iron
Volute Material	Cast Iron
Filtration Size	1/2" Solids (12.7 mm)
Length x Width x Height	21" x 17" x 16.4" (530 x 430 x 416 mm)
Product Weight	78 lbs (35.5 kg)

ENGINE	W210F
Engine Model	W210F
Engine Displacement	212 cc
Engine Type	4-Stroke, Air Cooled, Overhead Valve (OHV)
Fuel Type	Regular unleaded gasoline with a minimum octane rating of 87 and ethanol content of no more than 10% by volume.
Fuel Capacity	0.8 gal (3 L)
Spark Plug	F7RTC - Torch
Spark Plug Gap	0.028-0.030 in. (0.7-0.8mm)
Oil Type	SAE 10W-30
Oil Capacity	20 fl oz (0.6 L)
Low Oil Shutdown	Yes

INTRODUCTION

Congratulations on your purchase of a PoulanPro® branded product. This model is the result of our vast experience in the production of high- quality, cost-effective equipment.

It represents the high degree of reliability and innovation that PoulanPro® has dedicated itself to.

This manual will give you an understanding of the assembly, operation and basic maintenance of this unit. If you have any questions concerning the operation or maintenance, please contact us at support@poulanpro-power.us or 888-676-7909.

We want you to continue to use and be satisfied with your product for years to come, therefore please fully familiarize yourself, and others who plan on operating the product, with the proper safety and operation procedures before each use.

We continually seek advancements in product design and quality. Therefore, while this manual contains the most current product information available at the time of printing, there may be minor discrepancies between your product and this manual.

When contacting us about parts and/or service, you will need to supply the complete product and serial numbers of your unit.

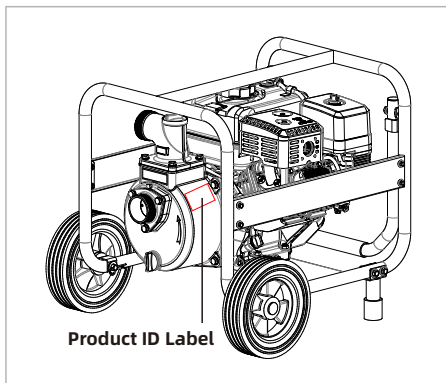

Record the following information to obtain service or warranty assistance

PRODUCT NUMBER

SERIAL NUMBER

DATE OF PURCHASE

SAFETY DEFINITIONS

The purpose of safety symbols is to attract your attention to possible dangers. The safety symbols, and their explanations, deserve your careful attention and understanding. The safety warnings do not by themselves eliminate any danger. The instructions or warnings they give are not substitutes for proper accident prevention measures.

⚠ DANGER

DANGER indicates a hazardous situation which, if not avoided, will result in death or serious injury.

⚠ WARNING

WARNING indicates a hazardous situation which, if not avoided, could result in death or serious injury.

⚠ CAUTION

CAUTION indicates a hazardous situation which, if not avoided, may result in minor or moderate injury.

💬 NOTICE

NOTICE indicates information considered important, but not hazard-related (e.g., messages relating to property damage).

IMPORTANT SAFETY INSTRUCTIONS

⚠ DANGER

Engine exhaust contains carbon monoxide, a colorless, odorless, poisonous gas. Breathing carbon monoxide can cause headaches, nausea, dizziness, drowsiness, confusion, fainting or death. If you start to feel dizzy or weak, leave the area immediately, get fresh air and Seek Medical Treatment.

ALWAYS OPERATE EQUIPMENT OUTDOORS ONLY, IN A WELL VENTILATED AREA.

NEVER operate the Outdoor Power Equipment inside any building, including garages, basements, sheds or other confined spaces.

DO NOT allow exhaust fumes to enter a confined area through windows, doors, vents or other openings while operating the product.

⚠ DANGER

Using an engine indoors **CAN KILL YOU IN MINUTES**. Engine exhaust contains carbon monoxide. This is a poison you cannot see or smell.



⚠ DANGER

DO NOT allow untrained individuals or children to use this unit.

⚠ WARNING

Rotating parts can entangle hands, feet, hair, clothing and/or accessories. Amputation or severe laceration can result.

Keep hands and feet away from rotating parts.

Tie up long hair and remove jewelry.

Operate equipment with guards in place.

DO NOT wear loose-fitting clothing, dangling drawstrings or items that could become caught.

⚠ WARNING

Before operating your machine, carefully read and understand all safety, controls and operating instructions in this Operator's Manual.

Failure to follow these instructions could result in property damage, serious personal injury or death.

⚠ WARNING

Clear the work area before each use. Remove all objects such as rocks, broken glass, nails, wire, or string which could cause risk of personal injury, be thrown or become entangled in the machine.

Always wear eye protection with side shields marked to comply with ANSI Z87.1. Failure to do so could result in objects being thrown into your eyes and other possible serious injuries.

Keep all bystanders, children, and pets at least 50' (15m) away when operating the unit.

Always wear sound protection (ear muffs or ear plugs) to reduce the risk of hearing loss associated with long term engine sound level(s).

Always wear heavy long pants, boots, gloves, and a long sleeve shirt. Do not wear loose clothing, jewelry, short pants, sandals, or go barefoot. Secure long hair so it is above shoulder level to prevent entanglement in rotating parts.

Do not operate this unit when you are tired, ill, or under the influence of alcohol, drugs, or medication.

Do not operate in poor lighting.

Always wear a face filter mask in dusty conditions to reduce the risk of injury associated with the inhalation of dust.

Do not overreach. Overreaching can result in loss of balance or exposure to contact with hot surfaces or rotating parts.

Always inspect the unit before each use for loose fasteners, fuel leaks, etc. Replace damaged parts.

Use only identical manufacturer's replacement parts and accessories. Use of any other replacement parts may create a hazard or cause product damage and void your warranty.

Maintain the equipment per maintenance instructions located in this Operator's Manual.

⚠ DANGER

Rotating parts can cause severe bodily injury. Stop the engine and ensure all components have stopped rotating before installing / changing parts or performing maintenance.

⚠ WARNING

Never operate ground engaging equipment near underground electric cables, telephone lines, pipes or hoses.

It is recommended to contact your utility provider or diggers hotline in your area before operating ground engaging equipment.

⚠ WARNING

Before performing any service to the unit: The engine switch must be in the OFF position and the engine completely stopped. Allow the engine to cool down, remove and ground the spark plug wire.

⚠ WARNING

Running engines produce heat. Severe burns can occur on contact. Combustible material can catch fire on contact.

DO NOT touch hot surfaces.

Avoid contact with hot exhaust gases.

Allow equipment to cool before touching.

When operating maintain at least 3 ft. (91.4 cm) of clearance on all sides to ensure adequate cooling.

Maintain at least 5 ft. (1.5 m) of clearance from combustible materials.

⚠ WARNING

Rapid retraction of the recoil cord will pull hand and arm towards the engine faster than you can let go. Broken bones, fractures, bruises or sprains could result. Unintentional startup can result in entanglement, traumatic amputation or laceration.

When starting the engine, pull the recoil cord slowly until resistance is felt and then pull rapidly to avoid kickback.

⚠ CAUTION

Prolonged exposure to vibrations could cause blood vessel or nerve damage in fingers, hands, and joints. If symptoms such as numbness, or loss of feeling in the fingers, hands, or joints occur, discontinue the use of the product and seek medical attention.

Fuel Safety**⚠ DANGER****GASOLINE AND GASOLINE VAPORS ARE HIGHLY FLAMMABLE AND EXPLOSIVE.**

Fire or explosion can cause property damage, severe burns or death.

Gasoline and gasoline vapors:

Gasoline is highly flammable and explosive.

Gasoline can cause a fire or explosion if ignited.

Gasoline is a liquid fuel, but its vapors can ignite.

Gasoline is a skin irritant and needs to be cleaned up immediately if spilled on skin or clothes.

Gasoline has a distinctive odor; prolonged exposure to gasoline fumes could cause serious long-term consequences. Seek fresh air if exposed more than a few minutes.

Gasoline expands or contracts with ambient temperatures. Never fill the gasoline tank to full capacity, as gasoline needs room to expand when temperatures rise.

In the case of any petroleum gasoline fire, flames should never be extinguished unless the fuel supply valve can be turned OFF. By not doing so, if a fire is extinguished and the supply of fuel is not turned OFF, an explosion hazard could be created.

⚠ CAUTION**When adding or removing gasoline:**

DO NOT light or smoke cigarettes while handling gasoline.

Always store or transfer gasoline in an EPA/CARB compliant fuel tank.

Never pump gasoline directly into the products fuel tank at the gas station.

Always drain gasoline outdoors in a well-ventilated area.

Always loosen fuel cap slowly to release any vapor pressure and to keep fuel from escaping around the fuel cap.

Always replace and tighten the fuel cap securely after fueling.

Always stop the engine and allow it to cool for a minimum of five minutes before refueling.

Never remove the fuel cap or add fuel while the engine is running or when the engine is hot.

DO NOT overfill the gasoline tank.

DO NOT tip the product allowing fuel or oil to spill.

In the event of spilled fuel, allow the fuel to evaporate fully, then move the product 10 ft. (3m) away from the refueling site before starting the engine to avoid potential ignition of fuel vapors.

Save these instructions. Refer to them frequently and use them to instruct others who may use this product.

⚠ WARNING

DO NOT attempt to start a damaged unit.

Always check that the gasoline cap, air filter, spark plug, fuel lines and the exhaust system are properly in place.

Always be certain that the unit is resting firmly on level ground.

⚠ DANGER

DO NOT pump gasoline or fuels, fuel-oil mixtures, acids, chemicals, detergents, liquids for human consumption, fertilizers, pesticides or any other flammable liquid or corrosive.

Water pumped through this unit shall not be used as drinking water.

⚠ CAUTION

When transporting the unit, always check that the fuel valve is in the OFF position.

⚠ WARNING

Never use a gasoline container, gasoline tank, or any other fuel item that is broken, cut, torn or damaged.

Safety Symbols

Some of the following symbols may be used on this product. Please study them and learn their meaning. Proper interpretation of these symbols will allow you to safely operate the product.

SYMBOL	MEANING
	Read Operator's Manual. To reduce the risk of injury, user must read and understand operator's manual before using this product.
	Eye and Ear Protection. Always wear safety goggles or safety glasses with side shields, and as necessary a full face-shield as well as full ear protection when operating this product. Always wear eye protection with side shields marked to comply with ANSI Z87.1.
	Footwear. Always wear safety shoes or heavy boots when operating the machine.
	Gloves. Always wear nonslip, heavy-duty protective gloves when operating this product.
	Safety Alert. This machine was built to be operated according to the safe operation practices in this manual. As with any type of power equipment, carelessness or error on the part of the operator can result in serious injury. This machine is capable of amputating fingers, hands, toes and feet and throwing foreign objects. Failure to observe the safety instructions could result in serious injury or death.
	Risk of Fire. Fuel and its vapors are extremely flammable and explosive. Fire can cause severe burns or death. Do not add fuel while the product is operating or still hot.
	Hot Surface. To reduce the risk of injury or damage, avoid contact with any hot surface.
	Open Flame Alert. Fuel and its vapors are extremely flammable and explosive. Keep fuel away from smoking, open flames, sparks, pilot lights, heat, and other ignition sources.
	Toxic Fumes. The engine exhaust from this product contains chemicals known to cause cancer, birth defects and other reproductive harm. Risk of Asphyxiation. This engine emits carbon monoxide, an odorless, colorless poison gas. Breathing carbon monoxide can cause nausea, fainting or death. Use only in a well-ventilated area.
	Clearance. Keep all objects including others at least 10 feet (3m) from this machine. Only one person should operate the tiller and load the logs.

KNOW YOUR PRODUCT

Read this manual thoroughly before operating your product. Familiarize yourself with the location and function of all controls and features. Failure to follow instructions could result in property damage, serious injury or death.

Save this manual for future reference.

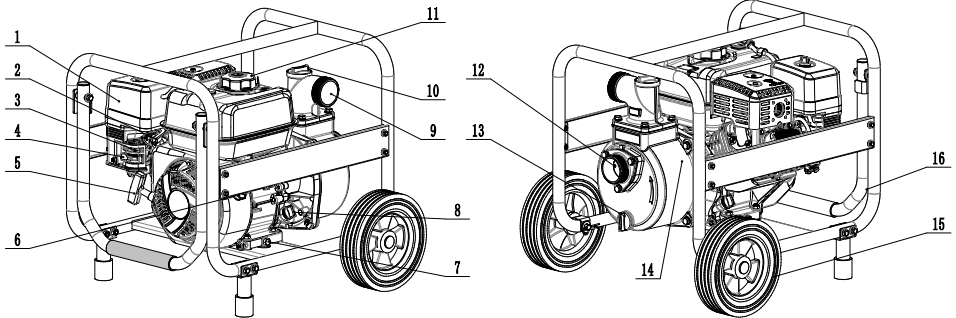

1	Air Filter
2	Throttle Lever
3	Choke Lever
4	Fuel Valve Lever
5	Recoil Starter Grip
6	ON / OFF Switch
7	Oil Drain Plug
8	Dipstick / Oil Fill Cap

9	Outlet / Discharge Port
10	Priming Filler Cap
11	Fuel Cap
12	Inlet / Suction Port
13	Pump Drain Cap
14	Product ID Lable
15	Wheel
16	Handle

UNPACKING

Carefully remove the water pump and loose parts from the carton and confirm the following parts are included. Please contact our technical support team at 1-888-676-7909 if any of the loose parts are not included with your pump.

PARTS INCLUDED

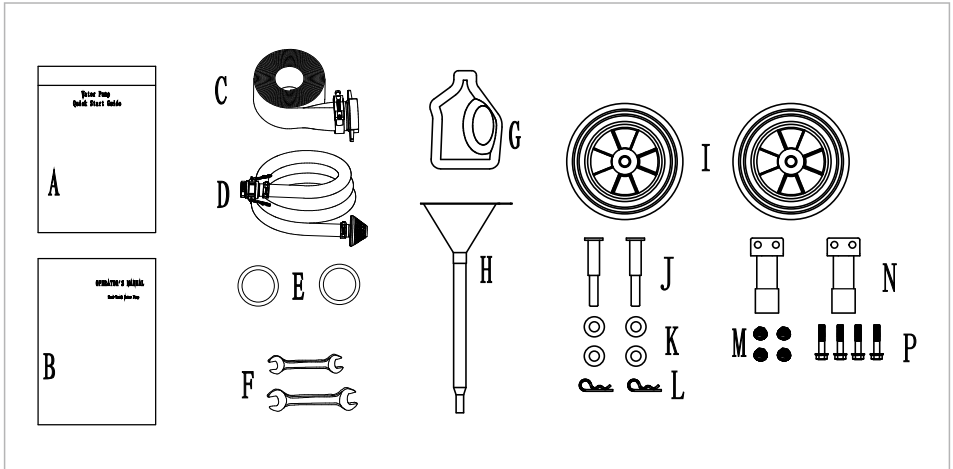

A	Quick Start Guide
B	Operator's Manual
C	Discharge Hose Assy
D	Suction Hose Assy
E	2 X Sealing Washer (Hose coupler)
F	Tool Kit (contains 13/16mm & 10/12mm Wrench)
G	Oil Bottle (20oz - 0.6L) 10W-30
H	Oil Funnel with Tube
I	2 x Wheel
J	2 X Axle Pin
K	4 X Washer
L	2 X Cotter Pin
M	4 X Nut
N	2 X Support Leg
P	4 X Bolt

ASSEMBLY

Your Water Pump requires limited assembly prior to use. If you have any questions regarding the assembly of this product, call our Technical Support Team at 1-888-676-7909 M-F 8 am-4 pm CST or by email at support@novospowerequipment.com Please have your model and serial number available at the time of the call.

Install Wheels & Support Legs

1. Insert axle pin (A) into wheel assembly (B), place washer (C) onto axle pin, slide through the wheel mount bracket and install washer (D) then secure with cotter pin (E). Repeat for second wheel.

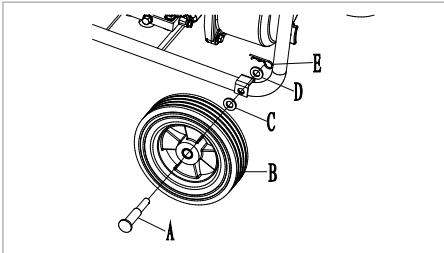

2. Install the support legs (B) using the 4 M8 x 40mm bolts (A) and M8 (C) lock nuts as shown.

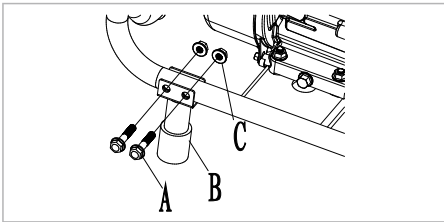

Add Engine Oil

CAUTION

This unit ships from our factory without oil. DO NOT attempt to crank or start the engine before it has been properly filled with the recommended type and amount of oil.

Running an engine with a low oil level can quickly cause engine damage. Damage to the engine resulting from failing to follow these instructions will void your warranty.

NOTE

SAE 10W-30 with a API service category of SJ or higher is recommended for general use. Other viscosities may be used when the average temperature is within the recommended range.

1. Place the unit on a flat, level surface.
2. Remove dipstick / oil fill cap to add engine oil.
3. Using a funnel, add up to 20 fl. oz. (0.6 L) of oil to the engine. The oil should be near the top of the filler neck.
4. Check the oil level using the dipstick. DO NOT screw in when checking.
5. When finished screw in the dipstick / oil fill cap securely.

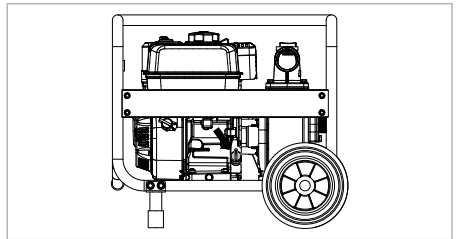

Recommended Engine Oil Type

Recommended Engine Oil Type	
° F	-20 0 20 40 60 80 100 120
° C	-28.9 -17.8 -6.7 4.4 15.6 26.7 37.8 48.9
Ambient temperature	

Engine / Dipstick Oil Level

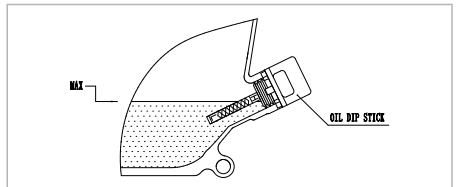

NOTE

Synthetic Oil may be used after the initial 20hr oil change. The use of synthetic oil does not change the recommended oil change intervals.

Add Fuel

The engine was designed to operate on unleaded gasoline with an octane rating of 87 or higher and a maximum ethanol content of 10% by volume.

The use of fuels with a content of ethanol greater than 10% can cause starting and/or performance problems, damage to metal, rubber and plastic parts of the fuel system. Engine performance problems or damage caused by using fuel with a higher ethanol content will not be considered for warranty.

⚠ DANGER

Gasoline and gasoline vapors are highly flammable and extremely explosive.

Always keep fuel away from sparks, open flames, pilot lights, heat and other sources of ignition.

Always Stop the engine and allow it to cool before refueling.

Only fill or drain fuel outdoors in a well-ventilated area.

DO NOT pump gasoline directly into the engine. Use an approved container to transfer the fuel to the engine.

Never use a gasoline container, gasoline tank, or any other fuel item that is broken, cut, torn or damaged.

DO NOT overfill the gasoline tank Wipe up spills immediately.

⚠ IMPORTANT

Use fresh, clean unleaded fuel with a minimum octane rating of 87 and a ethanol content of 10% or less by volume.

⚠ WARNING

Pouring gasoline too fast through the fuel screen may result in blow back of gasoline at the operator while filling.

Filling the fuel Tank

1. Remove the fuel tank cap.
2. Slowly add gasoline to the tank until it reaches the Red fuel level indicator of the fuel screen. **DO NOT** overfill. A minimum of ¼ in. (6.4 mm) of space left in the tank is required for gasoline expansion.
3. Replace and tighten the fuel tank cap.
4. Immediately wipe up any spills.

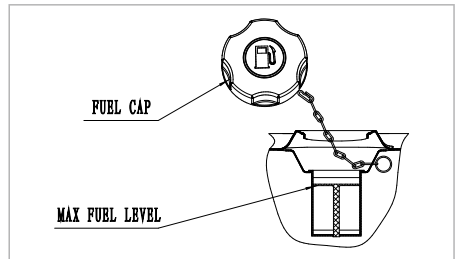

Notice:The engine works well with 10% or less ethanol blended gasoline. When using ethanol-gasoline blends there are some issues worth noting:

Ethanol-gasoline blends can absorb more water than gasoline alone.

These ethanol blends can eventually separate, leaving water or a watery goo in the tank, fuel valve and carburetor. The compromised gasoline can be drawn into the carburetor and cause a hard / no-start condition as well as damage to the carburetor and the entire fuel system.

If a fuel stabilizer is used, confirm that it is formulated to work with ethanol-gasoline blends.

Any damages or hazards caused by using ethanol blended gasoline higher than 10% by volume, improperly stored gasoline, and/or improperly formulated stabilizers, are not covered by manufacturer's warranty.

It is advisable to always shut off the gasoline supply and run the engine to starvation after each use. See Storage instructions for extended non-use.

OPERATION

⚠ WARNING

Before operating your machine, carefully read and understand all safety, controls and operating instructions in this Operator's Manual. Failure to follow these instructions can result in serious personal injury. Take the time to familiarize yourself with the controls and operation of the entire unit before use.

Pumping Location

For your safety and the safety of others, always inspect the area the pump will be working in. Place the pump in a well-ventilated area away from vents or intakes where exhaust fumes could enter a confined or occupied space. The pump should be on a level surface free from obstructions. For the best performance the pump should be placed as close to the water level as possible.

The Maximum Total Lift (Total Head) is the maximum total distance between the water level and the point of discharge. The Maximum Suction Lift (Suction Head) is the maximum distance between the water level and the pump.

💬 NOTE

The discharge capacity is greater than the suction capacity. Therefore, it is important that the suction head is less than the discharge head.

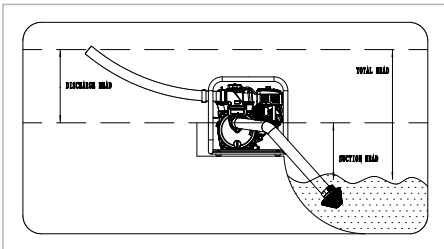

Connecting Outlet / Discharge & Inlet / Suction Hose

1. Assemble the sealing gasket (A), hose fitting (B) and coupler (C) Fig 1. Thread the assy onto the outlet / discharge port of the pump. Fig 2

Fig 1

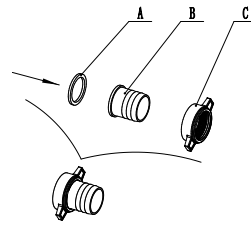
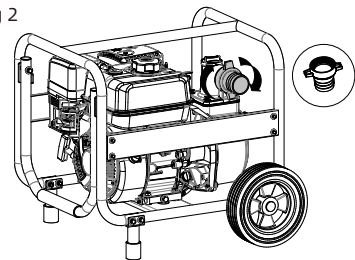

Fig 2



💬 NOTE

Ensure the sealing gasket is seated inside the coupler before threading the adapter on. Tighten firmly by hand.

2. Install a hose clamp over one end of the blue discharge hose, slide the hose completely over the full length of the adaptor. Position the hose clamp past the barbed section of the adaptor and securely tighten to prevent leaks.

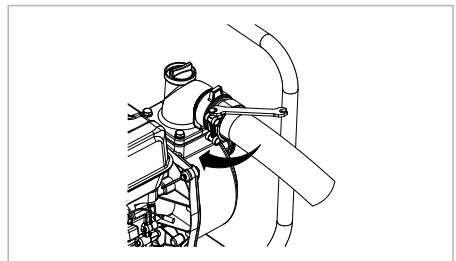

3. Separate the cam lock coupler and fitting (if assembled).

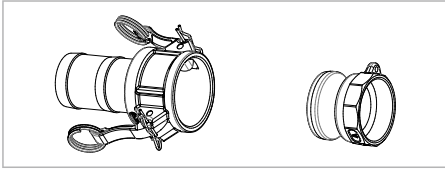

4. Thread the cam lock fitting onto the inlet / suction port of the water pump until tight.

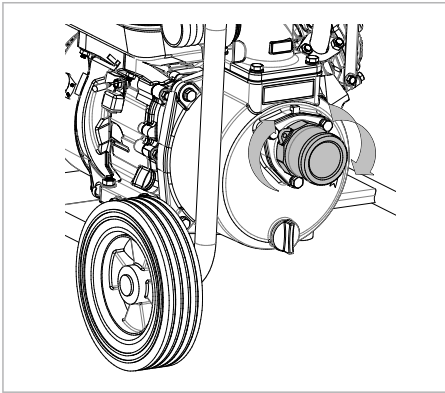

NOTE

To lessen the possibilities of an air leak, the use of Teflon[®] tape on the intake / suction port threads is recommended.

5. Attach the cam lock coupler onto the fitting.

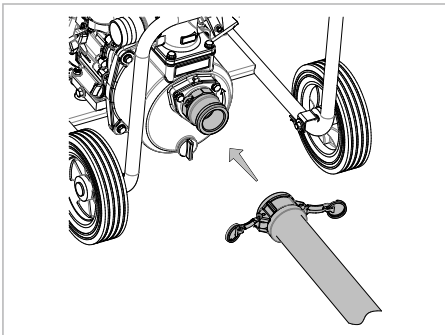

6. Lock the coupler in place with the cam levers.

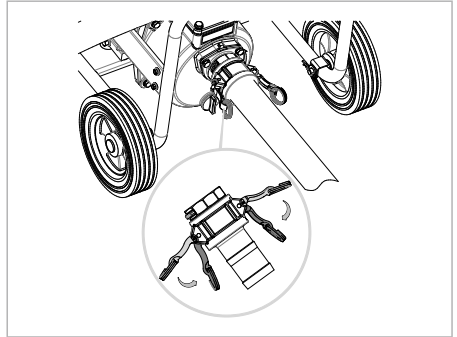

NOTE

For best pump performance avoid bends and/or sharp turns of the hose.

Priming the Pump

WARNING

Never start the pump without water or an approved liquid in the pump housing as damage to the pump seal will occur. Running a dry pump will void your warranty. Special attention must be given to ensure the intake / suction hose strainer is completely submerged at all times. If the pump was running while dry, stop the engine and allow it to cool completely before filling the chamber with water.

DANGER

DO NOT pump gasoline or fuels, fuel-oil mixtures, acids, chemicals, detergents, liquids for human consumption, fertilizers, pesticides or any other flammable liquid or corrosive. Water pumped through this unit shall not be used as drinking water.

1. Remove the priming filler cap and completely fill the chamber with water and begins to flow out of the discharge port.
2. Re-install the priming filler cap and tighten securely.

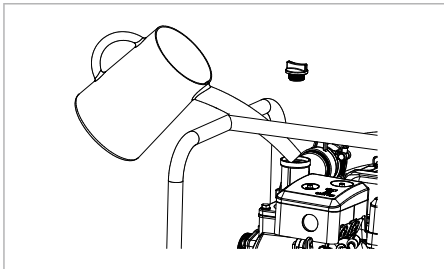
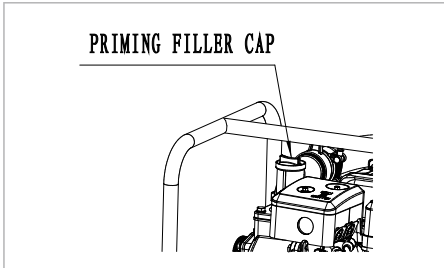

Starting the Engine

1. Position the unit on a flat level surface.
2. Slide the Throttle lever fully to the left (Full Throttle)
3. Slide the Choke Lever (A) to the full Choke position (Fully Left).
4. Move the Fuel Valve lever (B) to the ON position (Fully Right).
5. Turn the Engine Switch (C) to the ON position.

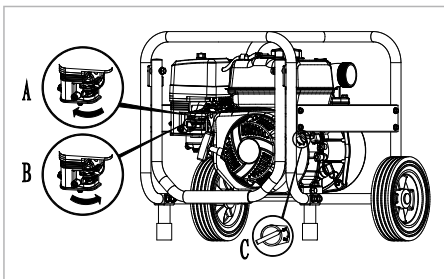

6. Pull the starter handle slowly until resistance is felt, then pull rapidly. Note: Return the starter handle slowly back to the engine to prevent damage to the starter.

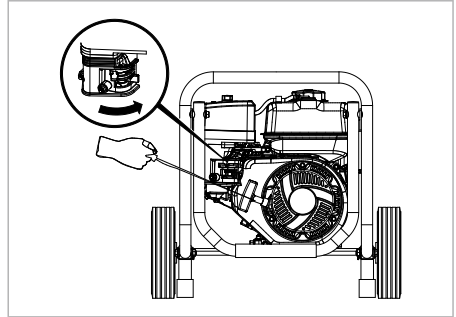

7. Once the engine starts, slowly slide the CHOKE lever to the OFF position. (Full Right)

⚠ WARNING

Rapid retraction of the recoil cord will pull hand and arm towards the engine faster than you can let go. Broken bones, fractures, bruises or sprains could result. Unintentional startups can result in entanglement, traumatic amputation or laceration.

When starting the engine, pull the recoil cord slowly until resistance is felt and then pull rapidly to avoid kickback.

If after several attempts the engine still does not start, contact our Technical Support Team at 1-888-676-7909 Mon-Fri 8-4 CST or Email: support@poulanpro-power.us

Stopping the Engine

Emergency: In an emergency, turn the engine switch to the "OFF" position.

Under normal operation:

1. Slide the fuel valve lever fully to the Left.
(Off position)

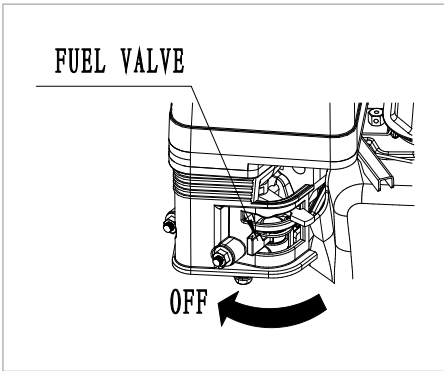

2. Turn the engine ignition switch to the OFF position.

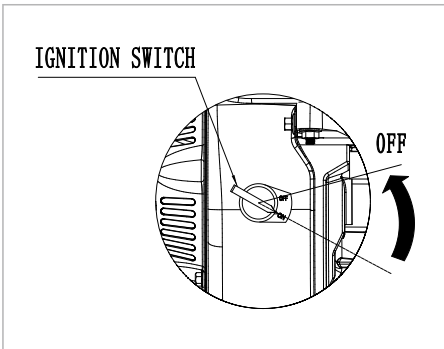

MAINTENANCE

Proper maintenance of your unit is important for maximum performance and a long service life.

To help you properly care for your unit, the following section includes a maintenance schedule and simple maintenance procedures. We suggest working with an Authorized Dealer, professional or qualified mechanic for any service which you are unfamiliar with, not mechanically proficient with or possess the proper tools.

The maintenance schedule provided applies to normal operating conditions. If your unit is operated under more severe conditions such as high-temperatures, sustained high-load or operation in dusty or unusually wet conditions, please inspect and service your unit more frequently.

DANGER

DO NOT use gasoline or low flash point solvents to clean the engine or any of its components. The possibility exists of fire or explosion which can damage the equipment and cause severe bodily harm or even DEATH.

WARNING

Some maintenance operations may require a running engine. ALWAYS make sure the maintenance area is well ventilated. Gasoline engine exhaust contains poisonous carbon monoxide gas that can result in unconsciousness and/or DEATH when inhaled.

CAUTION

ALWAYS allow the engine to cool before servicing. NEVER attempt to service a hot engine.

CAUTION

ALWAYS disconnect the spark plug wire from the spark plug and secure it away from the engine before performing maintenance or adjustments.

Failure to follow these instructions can result in serious personal injury or property damage.

NOTE

Maintenance, replacement, or repair of emission control devices and systems may be performed by any non-road engine repair establishment or individual.

Maintenance Schedule

Recommended Maintenance Schedule		Each Use	First 20 Hours or 1 Month	Every 50 Hours or 3 Months	Every 100 Hours or Every Season	Every 300 Hours	Before Storage
Engine Oil	Check	X					
	Replace		X		X (1)		
Air Filter	Check		X	X	X		
	Clean			X(1)	X (1)		
Spark Plug	Check		X		X		
	Replace				X	X	
Fuel	Check Level	X					
	Drain						X
Fuel Lines	Check				X		X
	Replace					X	
Hardware-Bolts/Nuts	Check		X		X		
Carburetor	Drain						X
Air Cooling System	Clean				X		
Valve Clearance	Check-Adjust					X (2)	
Pump - Damage / Leaks	Check	X					
Pump Chamber - Flush / Clean	Clean	X					X

1. Service more frequently when used in dusty conditions - Replace if worn or damaged.
2. These items should be maintained and repaired by an authorized dealer, unless the owner has appropriate tools and is proficient with mechanical maintenance.

Oil Change

NOTICE

Used oil is a hazardous waste product and must be disposed of properly. Check your local regulations for proper disposal/recycling facilities.

Change the engine oil after the first 20 hours of use. Thereafter, change the oil every 100 hours of use or every season. Change the oil more often if used in dusty conditions.

If possible, drain the oil while the engine is warm. Warm oil drains more quickly and completely. Refer to the adding engine oil section for the recommended oil for your operating environment.

1. Place a suitable container below the oil drain plug to catch the used oil.
2. Remove the oil filler cap/dipstick, the drain plug bolt and sealing washer from the engine.
3. Allow the oil to drain completely from the engine.
4. Reinstall and tighten the drain plug bolt with sealing washer.
5. Using a funnel, add up to 20.3 fl. oz. (0.6 L) of oil to the engine.
6. Check the oil level using the dipstick. DO NOT screw in when checking.
7. When finished screw in the dipstick / oil fill cap securely.

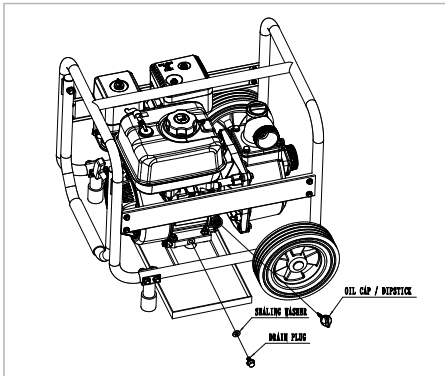

Air Filter

Check the air filter after the first 20 hours of use and clean the filter every 50 hours of use. Clean the filter more often when operating in a dusty environment. Replacement of the air filter is highly recommended at the first sign of excessive dirt build-up, oil/gas/water saturation, wear or damage.

Inspection & Cleaning

1. Remove the outer wing nut and air filter cover.
2. Unscrew the inner wing nut and remove the air filter element.
3. Remove the outer foam pre-filter from the paper filter. Check both elements for tears or holes. Replace the filter if damaged.
4. Paper Element - To remove the dirt, tap it several times on a hard surface. Replace the element if excessively dirty. Do Not use pressurized air or solvents to clean the air filter as damage can occur.
5. Foam Pre-Cleaner - Clean the pre-cleaner in warm soapy water and rinse. Squeeze out excess water from the filter and allow to dry completely before installation.
6. Being careful to prevent dirt from entering the air duct leading to the carburetor, wipe any dirt from the air filter housing and cover.
7. Install the foam pre-filter over the air filter element, install onto the housing. Secure the air filter with the inner wing nut making sure it is sitting flat and sealing on the housing base. Install the air cleaner cover and tighten the outer wing nut.

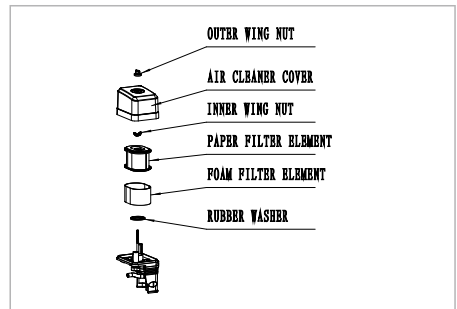

Spark Plug

Check the spark plug after the first 20 hours and every 100 hours of operation thereafter. Replace the spark plug after 300 hours of operation.

Recommended Spark Plug: Torch F7RTC or Equivalent.

Spark Plug Gap: 0.028-0.030 in. (0.7-0.8mm)

⚠ CAUTION

Always allow the engine to cool before performing maintenance, adjustments or service.

🗨 NOTICE

A loose spark plug can overheat and damage the engine

1. Remove the spark plug cap and clear away any dirt around the spark plug base.
2. Using a spark plug wrench, remove the spark plug.
3. Visually check the spark plug. Clean with a steel brush. If the insulator is damaged, replace the spark plug.
4. Measure the spark plug gap with a suitable gauge. Adjust the spark plug gap as necessary by carefully bending the ground electrode.
5. To prevent cross threading, thread the spark plug in by hand until it seats, then tighten with a spark plug wrench as follows.

New Spark Plug – Tighten $\frac{1}{2}$ turn after the plug seats to the cylinder head.

Used Spark Plug – Tighten $\frac{1}{8}$ to $\frac{1}{4}$ turn after the plug seats to the cylinder head.

6. Reconnect the spark plug cap.

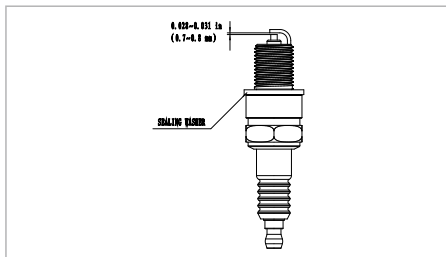

Pump

Limited maintenance is required on your pump. Here are 4 items that will keep your pump maintained and in good operating condition.

1. Using clean water, flush the internal pump chamber after each use.
2. Always drain the pump chamber prior to any short or long-term storage.
3. Keep the strainer clear of any blockage.
4. Keep the hose coupler sealing washers from hardening by disconnecting the coupler from the pump and using a light mist of lubricating spray on the washer.

TRANSPORTATION AND STORAGE

Transporting

If the unit has been running, allow it to cool before transporting. A hot muffler can cause burns and/or ignite nearby materials. To prevent fuel spills, always transport the pump in an upright position.

1. Turn the Engine switch to the OFF position.
2. Move the Fuel Valve Lever to the OFF position.
3. Strap or tie the unit down to prevent any sliding or tipping.

Off-Season Storage

Storage preparation is important for keeping your unit running trouble free, easier to start after storage on the overall service life of your unit.

When the unit will not be used for more than 30 days, prepare it for storage as follows:

⚠ DANGER

GASOLINE AND GASOLINE VAPORS ARE HIGHLY FLAMMABLE AND EXPLOSIVE.

Fire or explosion can cause property damage, severe burns or death.

Only fill or drain fuel outdoors in a well-ventilated area.

Store away from sparks, open flames, pilotlights, heat and other sources of ignition.

When storing the unit ensure the Engine Switch and Fuel Valve are set in the OFF position.

⚠ CAUTION

Always allow the engine to cool before performing maintenance, adjustments or service.

Engine

It is important to prevent gum deposits from forming in essential fuel system parts such as carburetor, fuel hose, or tank during storage

Fuel Stabilizer

Fuel stabilizers are an acceptable alternative in minimizing the formation of fuel gum deposits during storage.

Add stabilizer to gasoline in fuel tank or storage

container. Always follow the mix ratio found on stabilizer container. Run the engine at least 10 minutes after adding stabilizer to allow the stabilizer to reach the carburetor. Do not empty the gas tank and carburetor if using fuel stabilizer.

Drain the fuel tank and carburetor

1. Move the fuel valve lever to the OFF position.
2. Remove the carburetor drain screw and drain fuel into an approved gasoline container.
3. Slide the fuel valve lever to the ON position, allowing the fuel from the fuel tank to completely drain through the carburetor bowl.
4. Once draining is complete, reinstall the carburetor drain screw.
5. Move the Fuel valve lever to the OFF position.
6. Properly handle and dispose of drained fuel.

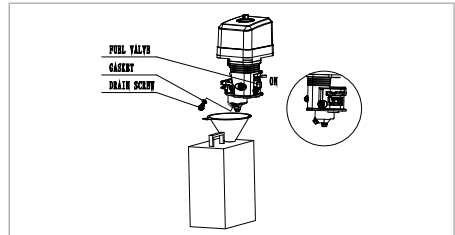

Oil

1. Change the engine oil. (See “Oil Change” in the Maintenance section)
2. Remove the Spark Plug.
3. Pour approximately one teaspoon of clean engine oil (5 cc) into the spark plug hole.
4. Slowly pull the starter rope several times to lubricate the cylinder walls of the engine.
5. Replace the spark plug and tighten 1/8 to 1/4 turn after the spark plug seats to the cylinder head.

Pump

1. Clean the internal pump by removing the priming and drain plug. Wash pump out with fresh water.
2. Allow the pump to drain as completely as possible. Reinstall the pump drain and priming plug.
3. Wipe down the unit to remove dirt and water.

Storage Location

Store your unit in a dry, well-ventilated place out of direct sunlight. Place a fabric cover over the unit. Do not use a plastic or vinyl cover as condensation could be trapped underneath which could increase the chances of rusting.

TROUBLESHOOTING

Problem	Cause	Solution
Engine does not start	Spark plug wire disconnected.	Reconnect wire.
	Engine Throttle Control Lever incorrectly set.	Move the throttle lever to the Fast position.
	Fuel tank is empty.	Refuel.
	Choke control in incorrect position.	Move lever to CHOKE position.
	Stale gasoline.	Drain the fuel tank and carburetor. Refuel with fresh gasoline.
	Dirty air filter.	Clean or replace filter.
	Switch is in "OFF" position.	Turn switch to "ON" position.
	Defective or incorrectly gapped spark plug.	Gap or replace spark plug.
	No spark.	Check engine switch is in ON position, Check oil level, Check / replace spark plug.
Engine runs poorly	Defective or incorrectly gapped spark plug.	Inspect spark plug gap or replace spark plug.
	Dirty air filter(s).	Clean or replace the air filter.
	Stale gasoline.	Drain the fuel tank and carburetor. Refuel with fresh gasoline.
Engine overheats	Engine cooling system clogged.	Clean cylinder cooling fins, recoil starter vents and behind engine shrouds.
	Oil level is low.	Add engine oil.
The engine starts, then shuts down after a short period	Fuel valve is not fully open or is clogged.	Open fuel valve and / or have carburetor cleaned.
	Low oil level .	Add engine oil.
	Float in carburetor is damaged or sticking.	Have the carburetor cleaned or rebuilt.
	Fuel is contaminated or deteriorated.	Drain & replace the fuel in the fuel tank and carburetor bowl.
	Carbon deposit and buildup on spark plug electrode.	Clean and re-gap or replace spark plug.
Pump is not Pumping	Pump was not primed.	Prime the pump.
	Debris has clogged the strainer.	Remove debris from strainer.
	Hose clamps on suction / intake are loose.	Tighten the hose clamps.
	Sealing washer on suction hose is damaged, loose or missing.	Inspect suction hose connection and address issue.
	Suction head is too high.	Adjust pump location to an appropriate level.
Low Pump Output	Engine running to slow.	Set the throttle to the FAST position.
	Strainer is clogged with debris.	Clean debris from strainer.
	Discharge or suction head to great.	Adjust to within the specified limits.
	Discharge or suction hose to long.	Reduce the hose length.

BASIC SERVICE PARTS LIST

For additional service or parts assistance, Contact Us at 1-888-676-7909 or by email at support@poulanpro-power.us.

PP20WPK: Common Service Parts

Service Part	Part Number
Spark Plug - F7RTC	2204700003-0001
Air Filter Assy w/pre-cleaner	1903400012-0001
Dipstick Assy	1101500002-0003
Oil Fill Plug Assy	1102200005-0002
Oil Drain Bolt	360290002
Sealing Washer - Oil Drain	3412100041-0001
Fuel Cap	1800900009-0001
Carburetor Assy	1807900112-0001
Fuel Line	1816200024-0001
EVAP Line	1816300054-0001
Recoil Starter Assy	2000200047-0005
Engine On / Off Switch	2205000001-0001
Cap -Priming Filler Plug	3103800001-0001
O-ring Priming Filler Cap	3107100001-0001
Drain Plug - Pump	3103800001-0001
O-Ring - Pump Drain Plug	3107100001-0001
Strainer Screen	3104100005-0001
Strainer Screen Base Connector	3104000006-0001
Intake Cam Lock Fitting	3106300001-0001
Intake Cam Lock Coupler	3105800001-0001
Outlet Coupler Ring	3104500017-0001
Outlet Barbed Adapter	3104200001-0001
Outlet Sealing Washer	3107200001-0002
Hose Clamp	3410600012-0001

WARRANTY STATEMENT

2-Year Limited Warranty Terms and Conditions

PoulanPro® is a registered trademark of Husqvarna AB and is used under license to Novus Performance Products LLC. Novus products are warranted for two (2) years against defects in materials or workmanship when put to ordinary and normal consumer use; ninety (90) days for any other use.

For the purposes of all the above warranties, "ordinary and normal consumer use" refers to non-commercial residential use and does not include misuse, accidents or damage due to inadequate maintenance. Novus Performance Products LLC certifies that Novus Products are fit for ordinary purposes for which a product of this type is used. Novus Performance Products LLC, however, limits the implied warranties of merchantability and fitness in duration to a period of two (2) years in consumer use, ninety (90) days for any other use.

The 2-Year Limited Warranty on Novus Products starts on the purchase date. The 2-Year Limited Warranty is applicable only to the original owner.

The warranty holder is responsible for the performance of the required maintenance as defined by the manufacturer's owner's manuals. The warranty holder is responsible for replacement of normally wearing parts such as the Belt, Shear Pins, Spark Plug and Air Filter. Accessories to the machine are not covered by this warranty.

During the warranty period, the warranty holder is responsible for the machine transportation charges, if required.

During the warranty period, warranty parts will be shipped by standard method at no charge to the warranty holder. Expedited shipping of warranty parts is the responsibility of the warranty holder.

SOME STATES DO NOT ALLOW LIMITATIONS ON THE LENGTH OF IMPLIED WARRANTIES, SO THE ABOVE LIMITATIONS MAY NOT APPLY TO YOU.

Novus Performance Products LLC shall not be liable under any circumstances for any incidental or consequential damages or expenses of any kind, including, but not limited to, cost of equipment rentals, loss of profit, or cost of hiring services to perform tasks normally performed by Novus Products.

SOME STATES DO NOT ALLOW THE EXCLUSION OR LIMITATION OF INCIDENTAL OR CONSEQUENTIAL DAMAGES, SO THE ABOVE LIMITATIONS MAY NOT APPLY TO YOU.

THIS WARRANTY GIVES YOU SPECIFIC LEGAL RIGHTS, AND YOU ALSO HAVE OTHER RIGHTS, WHICH VARY FROM STATE TO STATE.

Technical Support:

Toll free: 1-888-676-7909 Mon-Fri 8-4 CST

Email: support@poulanpro-power.us

U.S. FEDERAL EMISSION CONTROL WARRANTY STATEMENT YOUR WARRANTY RIGHTS AND OBLIGATIONS

The United States Environmental Protection Agency and Novus Performance Products LLC (Novus) are pleased to explain the emissions control system warranty on your 2024-2025 small off-road engine/equipment (SORE). In the United States, new equipment that use small off-road engines must be designed, built, and equipped to meet the State's stringent anti-smog standards. Novus must warrant the emissions control system on your small off-road engine/equipment for the periods of time listed below there has been no abuse, neglect or improper maintenance of your small off-road engine or equipment leading to the failure of the emissions control system.

Your emissions control system may include parts such as the carburetor or fuel-injection system, the ignition system, catalytic converter, fuel tanks, fuel lines (for liquid fuel and fuel vapors), fuel caps, valves, canisters, filters, clamps and other associated components. Also included may be hoses, belts, connectors, and other emission-related assemblies.

Where a warrantable condition exists, Novus will repair your small off-road engine/equipment at no cost to you including diagnosis, parts and labor.

MANUFACTURER'S WARRANTY COVERAGE:

This emissions control system on your small off-road engine/equipment is warranted for two years. If any emission-related part on your small off-road engine/equipment is defective, the part will be repaired or replaced by Novus.

OWNER'S WARRANTY RESPONSIBILITIES:

As the small off-road engine/equipment owner, you are responsible for the performance of the required maintenance listed in your owner's manual. Novus recommends that you retain all receipts covering maintenance on your small off-road engine/equipment, but Novus cannot deny warranty coverage solely for the lack of receipts or for your failure to ensure the performance of all scheduled maintenance.

As the small off-road engine/equipment owner, you should however be aware that Novus may deny you warranty coverage if your small off-road engine/equipment or a part has failed due to abuse, neglect, or improper maintenance or unapproved modifications.

You are responsible for presenting your small off-road engine/equipment to a Novus distribution center or service center as soon as the problem exists. The warranty repairs shall be completed in a reasonable amount of time, not to exceed 30 days. If you have any questions regarding your warranty rights and responsibilities, you should contact:

Novus Performance Products LLC
customer service representative
1-800-409-7802
Email: Support@novuspowerequipment.com

DEFECTS WARRANTY REQUIREMENTS

(a) Applicability. This section applies to emissions control systems on small off-road engines or equipment that use small off-road engines subject to the emission standards in this Article. The warranty period begins on the date the engine or equipment is delivered to an ultimate purchaser and extends for a period of two years.

(b) General Emissions Warranty Coverage. The engine or equipment must be warranted to the ultimate purchaser and any subsequent owner that the emissions control system when installed was:

- (1) Designed, built, and equipped so as to conform with all applicable regulations; and
- (2) Free from defects in materials and workmanship that causes the failure of a warranted part for a period of two years.

(c) The warranty on emissions-related parts will be interpreted as follows:

- (1) Any warranted part that is not scheduled for replacement as required maintenance in the written instructions required by subsection (e) must be warranted for the warranty period defined in subsection (b)(2). If any such part fail during the period of warranty coverage, it must be repaired or replaced by Novus or its contracted warranty provider according to subsection (4) below. Any such part repaired or replaced under the warranty must be warranted for a time not less than the remaining warranty period.
- (2) Any warranted part that is scheduled only for regular inspection in the written instructions required by subsection (e) must be warranted for the warranty period defined in subsection (b)(2). A statement in such written instructions to the effect of "repair or replace as necessary" shall advise owners of the warranty coverage for emissions related parts. Replacement within the warranty period is covered by the warranty and will not reduce the period of warranty coverage. Any such part repaired or replaced under warranty must be warranted for a time not less than the remaining warranty period.
- (3) Any warranted part that is scheduled for replacement as required maintenance in the written instructions required by subsection (e) must be warranted for the period of time prior to the first scheduled replacement point for that part. If the part fails prior to the first scheduled replacement, the part must be repaired or replaced by Novus according to Subsection (4) below. Any such part repaired or replaced under warranty must be warranted for a

time not less than the remainder of the period prior to the first scheduled replacement point for the part.

- (4) Repair or replacement of any warranted part under the warranty provisions of this article must be performed at no charge to the owner at a warranty station.
- (5) Notwithstanding the provisions of subsection (4) above, warranty services or repairs must be provided at distribution centers that are franchised to service the subject small off-road engine/equipment.
- (6) The small off-road engine/equipment owner must not be charged for diagnostic labor that leads to the determination that a warranted part is in fact defective, provided that such diagnostic work is performed at a warranty station.
- (7) Throughout the emissions control system's warranty period set out in subsection (b)(2), Novus or its contracted warranty provider must maintain a supply of warranted parts sufficient to meet the expected demand for such parts and must obtain additional parts if that supply is exhausted.
- (8) Manufacturer-approved replacement parts that do not increase the exhaust or emissions of the engine or emissions control system must be used in the performance of any warranty maintenance or repairs and must be provided without charge to the owner. Such use will not reduce the warranty obligations of Novus or its contracted warranty provider.
- (9) The use of add-on or modified parts may be grounds for disallowing a warranty claim made in accordance with this Article. Novus or its contracted warranty provider will not be liable under this Article to warrant failures of warranted parts caused by the use of an add-on or modified part.
- (10) Novus shall provide any documents that describe that its warranty procedures or policies within five working days of request by the Executive Officer.
- (d) A list of all emissions warranty parts must be included with each new engine or equipment subject to this Article. The emissions warranty parts list shall include all parts whose failure would increase exhaust and evaporative emissions, and contains the following parts:

EMISSIONS PARTS LIST

Exhaust Emission

- (1) Fuel Metering System
- (A) Carburetor and internal parts (and/or pressure regulator or fuel injection system).

- (B) Air/fuel ratio feedback and control system.
- (C) Cold start enrichment system.
- (2) Air Induction System
- (A) Controlled hot air intake system.
- (B) Intake manifold.
- (C) Air filter.
- (3) Ignition System
- (A) Spark Plugs.
- (B) Magneto or electronic ignition system.
- (C) Spark advance/retard system.
- (4) Exhaust Gas Recirculation (EGR) System
- (A) EGR valve body, and carburetor spacer if applicable.
- (B) EGR rate feedback and control system.
- (5) Air injection System
- (A) Air pump or pulse valve.
- (B) Valves affecting distribution of flow.
- (C) Distribution manifold.
- (6) Catalyst or Thermal Reactor System
- (A) Catalytic converter.
- (B) Thermal reactor.
- (C) Exhaust manifold.
- (7) Particulate Controls
- (A) Traps, filters, precipitators, and any other device used to capture particulate emissions.
- (B) Miscellaneous items Used in Above Systems
- (A) Vacuum, temperature, and time sensitive valves and switches.
- (B) Electronic controls.
- (C) Hoses, belts, connectors, and assemblies.

Evaporative Emission

- (1) Fuel Tank
- (2) Fuel Cap
- (3) Fuel lines(for liquid fuel and fuel vapors)
- (4) Fuel Line Fittings
- (5) Clamps
- (6) Pressure Relief Valves
- (7) Control Valves
- (8) Control Solenoids
- (9) Electronic Controls

- (10) Vacuum Control Diaphragms
- (11) Control Cables
- (12) Control Linkages
- (13) Purge Valves
- (14) Gaskets
- (15) Liquid/Vapor Separator
- (16) Carbon Canister
- (17) Canister Mounting Brackets
- (18) Carburetor Purge Port Connector

Note: As they relate to the emissions control system.

(e)Written instructions for the maintenance and use of the emissions control system by the owner shall be furnished with each new engine or equipment subject to this Article. The instructions must be consistent with this Article and applicable regulations contained herein.

(f)The documents required by subsections (d) and (e) must be submitted with the application for emissions control system certification for approval by the Executive Officer. Approval by the Executive Officer of the documents required by subsections (d) and (e) is a condition of certification. The Executive Officer will approve or disapprove the documents required by subsections (d) and (e) within 90 days of the date such documents are received.

(g)The application for emissions control system certification must also include a statement regarding the maintenance of the emissions control system. The statement must include, but not be limited to, information on emissions control system maintenance, and a maintenance schedule.

(h)Any other warranty statements applicable to engines or equipment units must not imply a limitation on the emissions warranty period or its applicability to subsequent owners after the ultimate purchaser. If the warranty period for any warranty other than the emissions warranty is less than two years, the statement of such warranty must specifically state that it does not limit the emissions warranty period of two years from purchase. If any warranty other than the emissions warranty does not extend to subsequent owners after the ultimate purchaser, the statement of such warranty must specifically state that it does not affect the applicability of the emissions warranty to subsequent owners after the ultimate purchaser.