

FEATURE TABLE		
ITEM	QTY	DESCRIPTION
A	6	U/L MNTG.EMBOSS
B	1	¼ SOLID K.O.
C	1	¼, ½ CONC. K.O.
D	3	1¼, 1½, 2, 2½, 3 CONC. K.O.
E	3	2, 2½, 3 CONC. K.O.

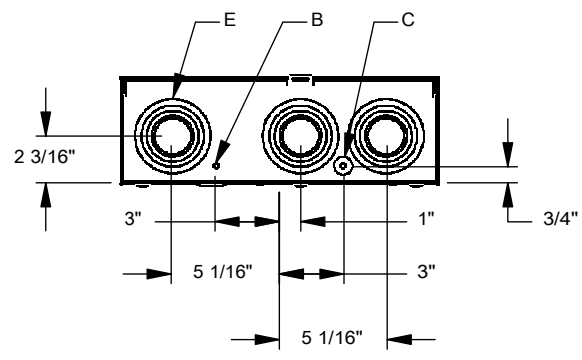
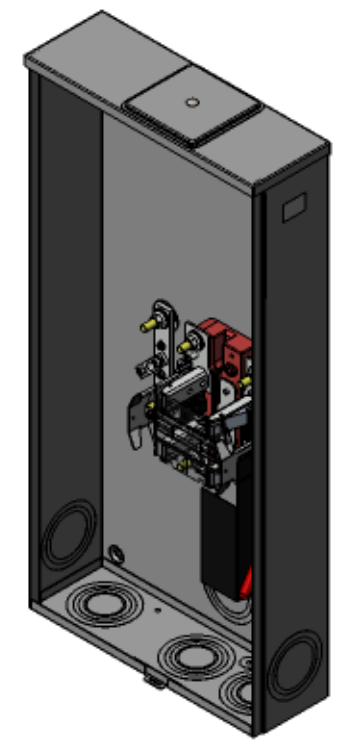
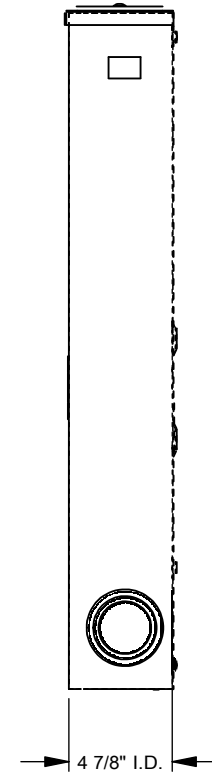
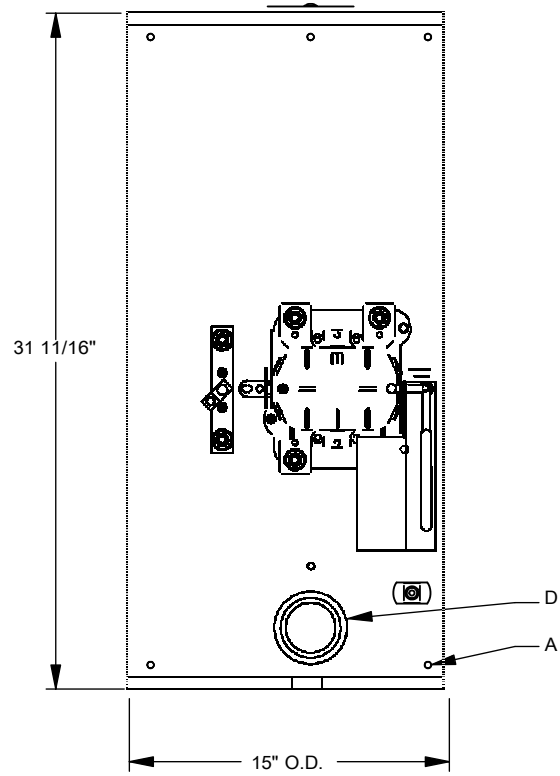

Version:

1

All dimensions are +/- 1/16" .
 Drawing views are not to scale.
 Utility requirements for this equipment may vary. Always consult with the local utility for installing this equipment. This product be installed by a licensed electrician. Installation of this equipment may require