



Laminate 4-in-1 Multifunctional Moulding Installation Instructions

Step 1: Review Installation Checklist

- Do not push parts into track until ready to install in final position.
- Do not remove from track once installed.
- Use a new saw blade for best cutting results.
- Depending on moulding type, all parts may NOT be used.
- Always install screws in end holes of track and then every other hole.
- For concrete floors, drill hole using 3/16" (5mm) diameter drill, insert plastic anchor, then use screw.
- Attach the track directly to the subfloor (remove any padding or underlayment).
- Laminate flooring installations require the use of T-Mouldings in doorways 4 feet (1.22 meters) or less and in rooms 40 feet (12.2 meters) or larger in length or width.
- This product has been finished for you; do not sand or paint.

Step 2: Choose Your Transition Type

Kit allows assembly of four different moulding options from one single product.

A. T-Moulding

Transitions between hard surface floors of equal height.

B. Carpet Transition

Finishes a hard surface floor where it meets carpet.

C. Hard Surface Reducer

Transitions between hard surface floors of different heights.

D. End Moulding

Finishes a hard surface floor at sliding doors, fireplaces and other fixed edges.



Laminate 4-in-1 Multifunctional Moulding Installation Instructions

Step 3: Install Your Mouldings

Each individual package includes the following:



Accommodates 7mm to 15mm Floor Thickness

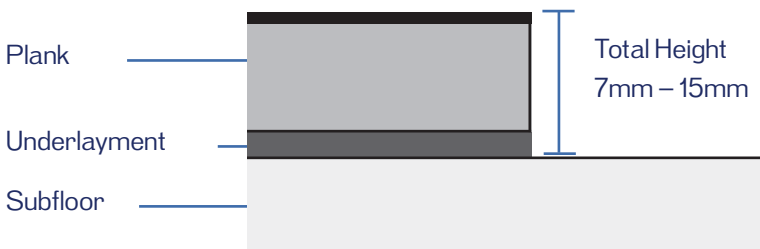

Total Height = Plank + Underlayment

- 9/32" to 15/32" (7mm to 12mm) - Track only
- 15/32" to 9/16" (12mm to 14mm) - Track plus snap on plastic shim
- 9/16" to 19/32" (14mm to 15mm) - Track over reversed plastic shim

Symbol Key

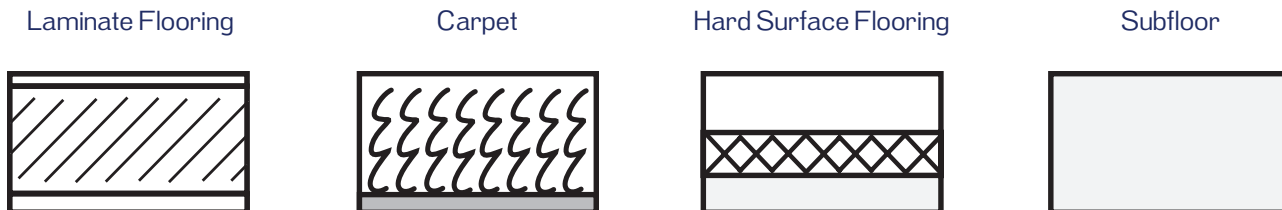



Laminate 4-in-1 Multifunctional Moulding Installation Instructions

A. T-Moulding

Use Part 1



Part 1

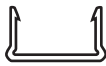

Track

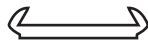

Shim



Screws



Plastic Anchors
(Use when installing
on concrete subfloors)

1. Leave a 1-1/8" (29mm) space between flooring as shown.
2. Install track in position with screws as shown. Leave 1/4" (6mm) expansion space on both sides of track.
3. Start at one end. Firmly push part 1 down into track.
4. Continue to push down firmly into track, working from one end to the other.

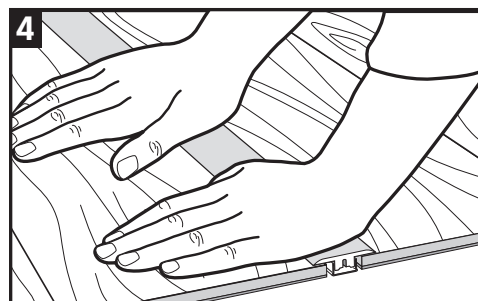
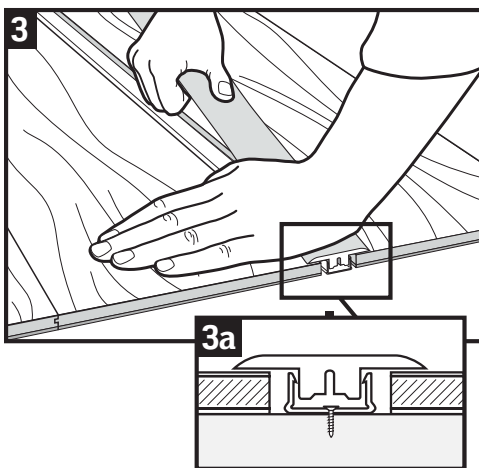
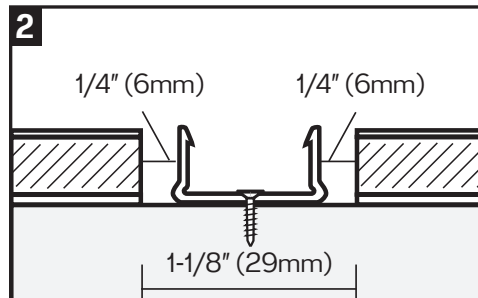
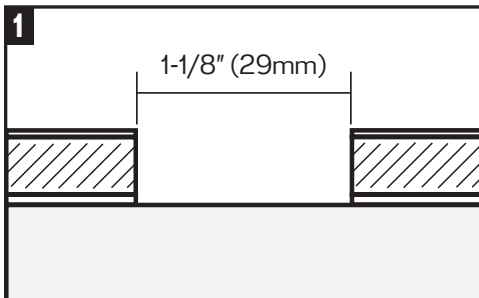



Laminate 4-in-1 Multifunctional Moulding Installation Instructions

B. Carpet Transition

Use Part 1 and Part 2



Part 1



Part 2



Track

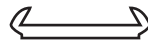

Shim



Screws



Plastic Anchors
(Use when installing on
concrete subfloors)

1. Leave a 1-3/8" (35mm) space between laminate flooring and carpet as shown.
2. Install track in position with screws as shown. Leave 1/2" (12mm) expansion space between track and laminate flooring.
3. Hold part 1 and part 2 together as shown in image 3.
4. Start at one end and push down firmly into track while holding part 1 and part 2 together.
5. Continue to push down firmly into track, working from one end to the other.

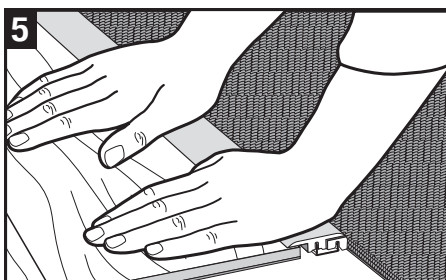
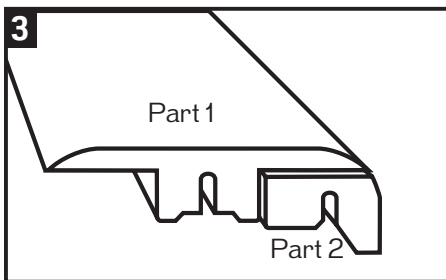
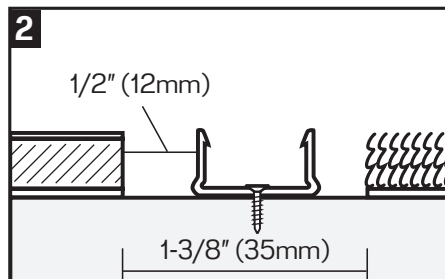
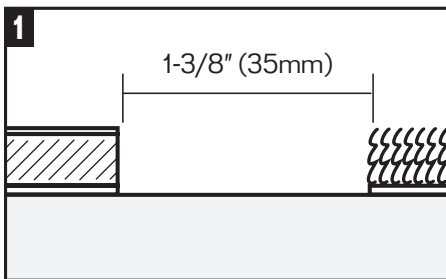

C. Hard Surface Reducer

Use Part 1 and Part 3

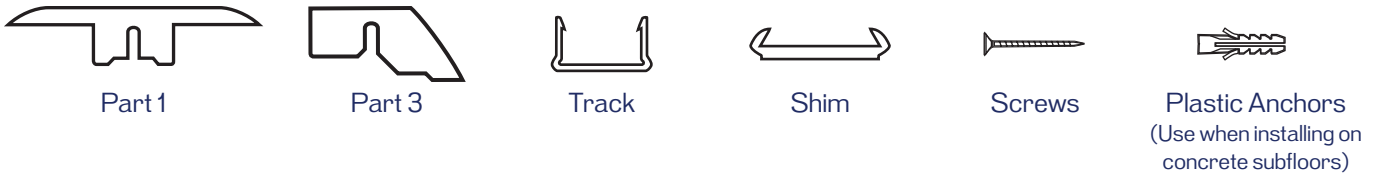

1. Leave a 1-3/8" (35mm) space between laminate flooring and hard surface as shown.
2. Install track in position with screws as shown. Leave 1/2" (12mm) expansion space between track and laminate flooring.
3. Hold part 1 and part 3 together as shown in image 3.
4. Start at one end and push down firmly into track while holding part 1 and part 3 together.
5. Continue to push down firmly into track, working from one end to the other.

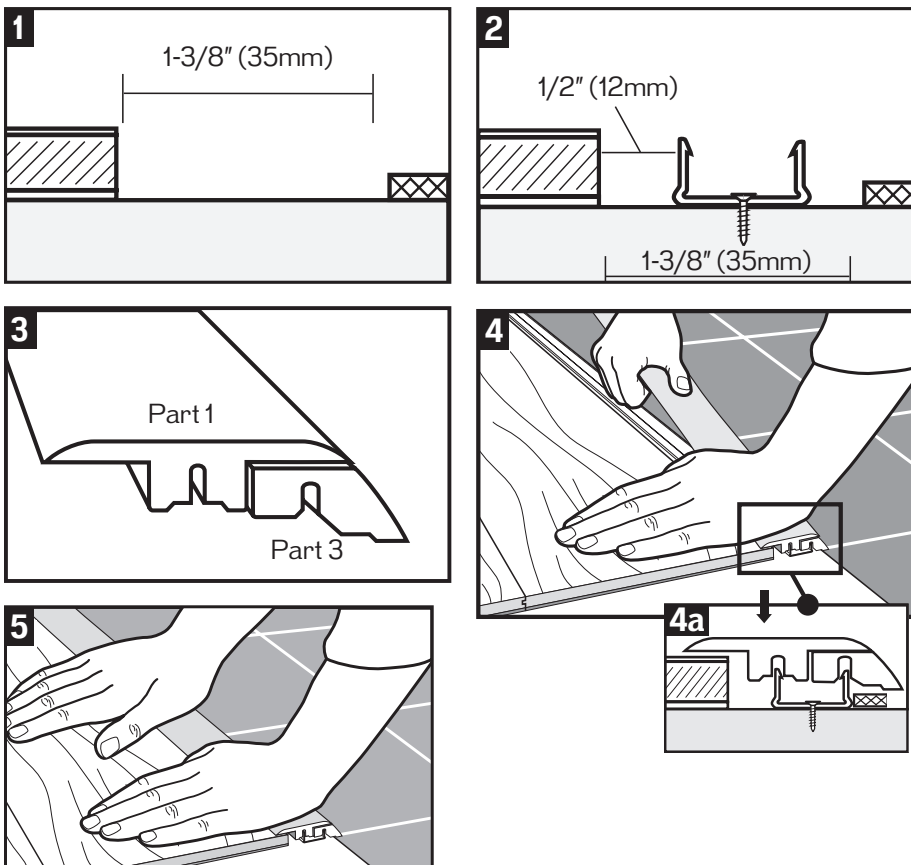

Laminate 4-in-1 Multifunctional Moulding Installation Instructions

D. End Moulding

Use Part 1 and Part 2

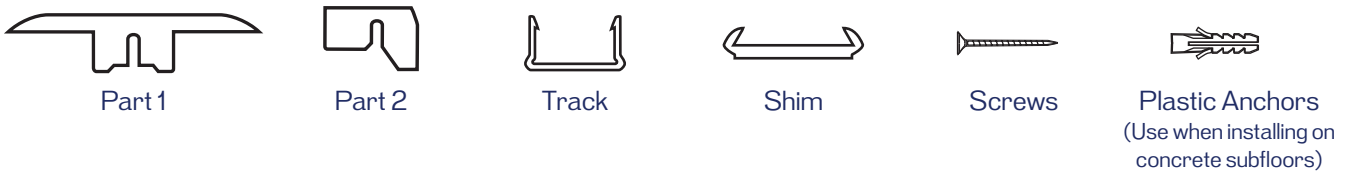

1. Leave a 1-3/8" (35mm) space between laminate flooring and vertical edge as shown.
2. Install track in position with screws as shown. Leave 1/2" (12mm) expansion space between track and laminate flooring.
3. Hold part 1 and part 2 together as shown in image 3.
4. Start at one end and push down firmly into track while holding part 1 and part 2 together.
5. Continue to push down firmly into track, working from one end to the other.
6. Fill any space between end moulding and vertical surface with 100% silicone sealant.

