

# **VEVOR**

**Affordable. Reliable. Home Improvement.**

**WOOD FIRED PIZZA OVEN**

**MODEL: SRGP025**



# VEVOR

Affordable. Reliable. Home Improvement.

## WOOD FIRED PIZZA OVEN

**MODEL:SRGP025**

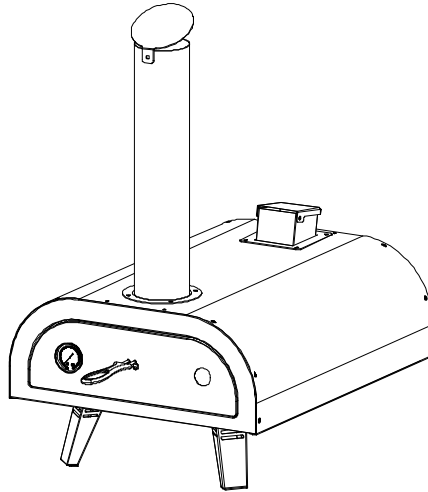

This is the original instruction, please read all manual instructions carefully before operating. VEVOR reserves a clear interpretation of our user manual. The appearance of the product shall be subject to the product you received. Please forgive us that we won't inform you again if there are any technology or software updates on our product.



**Warning-To reduce the risk of injury, user must read instructions manual carefully.**

## **Warnings**

- This pizza oven is FOR OUTDOOR USE only and shall not be used in a building, garage, under overhangs or any other enclosed area.
- DO NOT leave a lit pizza oven unattended. Keep children and pets away from the pizza oven at all times.

### **PROP 65 WARNING:**

This product can expose you to chemicals including Chromium (hexavalent compounds), which are known to the State of California to cause cancer and birth defects or other reproductive harm. For more information visit [www.P65Warnings.ca.gov](http://www.P65Warnings.ca.gov).

### **IMPORTANT SAFETY**

Please read this manual carefully and before installing or using your gas pizza oven to ensure This manual should be retained for your information.

### **LOCATION OF PIZZA OVEN**

Remember that your pizza oven is an outdoor appliance. Ensure your pizza oven is positioned safely away from garages or any other enclosed area. This outdoor cooking gas appliance is not approved to be installed in or on any recreational pizza ovens are intended for single-family/residential use only.

Minimum clearance from sides and back of unit to combustible construction, 36 inches from back and sides.

When determining a suitable location, take into account concerns such as exposure to wind, proximity to Proper location and use is also essential to ensure safe and continued trouble-free operation. Any non-approved alterations made to the pizza oven will void its warranty.

### **INSTALLATION WARNINGS**

Please read all installation, operating, and maintenance instructions thoroughly before installing or servicing this equipment.

## **Warnings**

This pizza oven is for outdoor use only. The manufacturer cannot be held responsible for damage or injury caused by improper use of this appliance.

### **FUEL CONCERNS & EXPLOSION HAZARDS**

Do not store or use gasoline or other flammable vapors and liquids (that are not connected for use) in the vicinity of this or any other appliance. Keep the area clear and free from combustible materials, gasoline, and

other flammable vapors and liquids, Failure to do so can result in death, explosion or fire.

Keep an ABC fire extinguisher accessible at all times, and never attempt to extinguish a grease fire with water or other liquids. Do not attempt to heat unopened containers on the pizza oven. Pressure may build up and cause the container to explode. Never use charcoal or any other solid fuel in the pizza oven.

## **PROPER USE PIZZA OVEN**

This pizza oven is NOT intended for commercial use. Do not operate the pizza oven in a building, garage, or any other enclosed areas. This could result in carbon monoxide buildup, which may cause injury or death. Pizza ovens are not designed or intended for installation near a window or vent that feeds into the house.

Consult the AHJ (Authority Having Jurisdiction) or a contractor in your area if you have any uncertainty regarding local codes.

## **GENERAL WARNING**









- Do not touch hot surfaces.
- Use insulated oven mitts when operating the pizza oven.
- Never lean over the cooking surface when lighting or operating the pizza oven.
- Close supervision is necessary when this or any pizza oven is used near children.

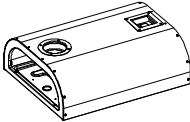

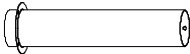
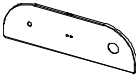
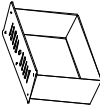
Keep children away from the grill during operation and until it has cooled off.

- Never operate this pizza oven while under the influence of alcohol or drugs.
- Do not store anything in the pizza oven. Make sure food is not forgotten in the pizza oven body; forgotten items could melt or catch fire when the pizza oven is turned on. Never use the pizza oven in WINDY conditions. If located in a consistently windy area (oceanfront, mountaintop, etc.), a wind break will be required. Winds blowing into the back can result in poor performance and/or cause the control panel and knobs to get dangerously hot.

To prevent injuries, do not use accessories that are not recommended by the manufacturer. The use of accessories, regulators, or components not recommended by the appliance manufacturer may cause injuries and will void warranty.





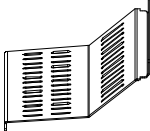
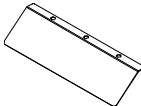
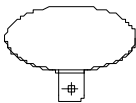

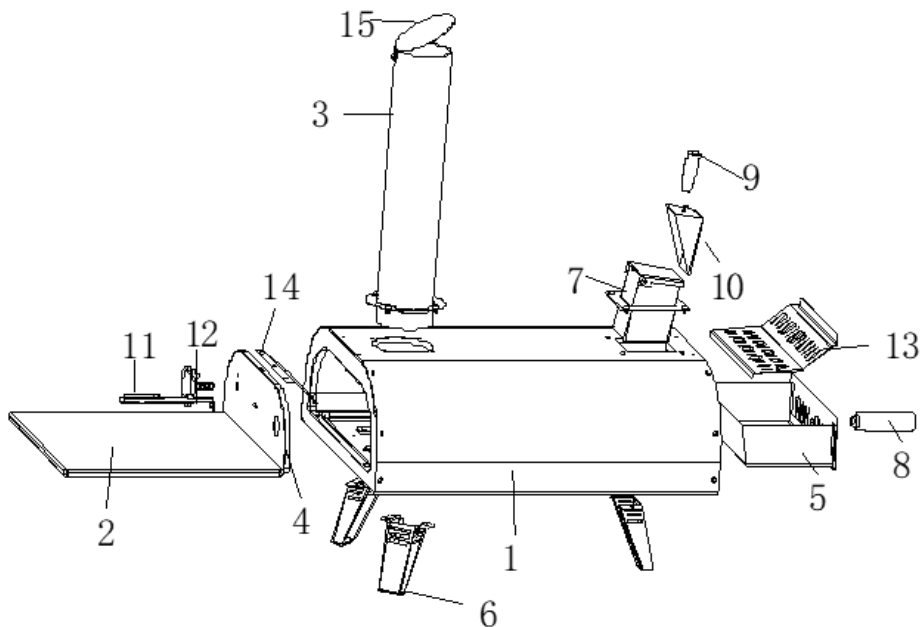
**NOTICE:** Make sure all the plastic protection rip off before assembling!

Parts Number	NAME	PART	QTY
1	Pizza oven body		1
2	Pizza stone		1
3	Chimney		1
4	Door		1
5	Pellet box		1
6	Support legs		3
7	Pellet inlet		1
8	Pellet box handle		1
9	Pellet shovel handle		1
10	Pellet shovel		1

11	door handle		1
12	Thermometer		1
13	Pellet box grate		1
14	Temperature barrier		1
15	Chimney cover		1



**Product diagram**  
**HARDWARE PACK CONTENTS**

A	 Bolt: M6x15	1pcs	B	 Bolt: M5x10	6pcs
C	 Bolt: M4x15	11pcs	D	 Bolt: M4x10	3pcs
E	 Bolt: M8x15	1 pcs	F	 Bolt:	
G	 Bolt:				

with package contents list on previous page and hardware contents below. If any part is missing or damaged, do not attempt to assemble the product. Contact customer service for replacement parts.

**CAUTION:**

Some parts may contain sharp edges. Wear protective gloves if necessary. Read and follow all safety statements, warnings, assembly instructions and use and care instructions before attempting to assemble and use.

**Assembly**

1. Remove all contents from packaging, and make sure all the parts are present before attempting to assemble!.
2. Assemble the support legs (part 6) onto the pizza oven body (part 1) as shown. Use the Bolt B to tighten it.

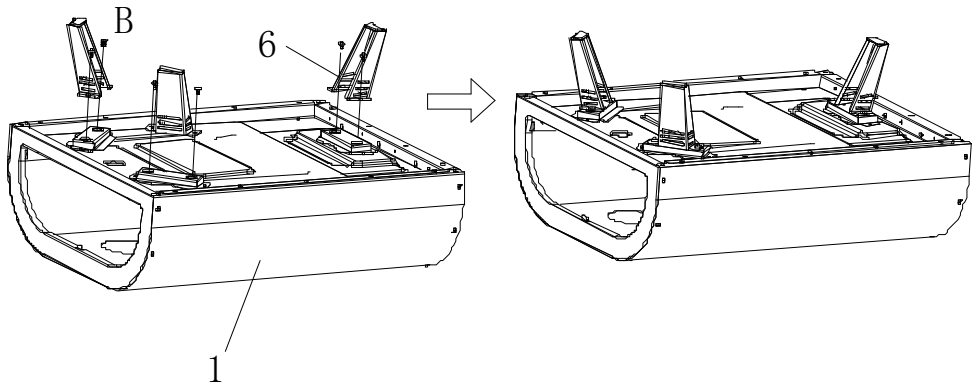

3. Assemble the chimney cover (part 15) onto the chimney (part 3) as shown. Use the Bolt C to tighten it.  
Assemble the chimney (part 3) onto the pizza oven body (part 1) as shown. Use the Bolt C to tighten it.

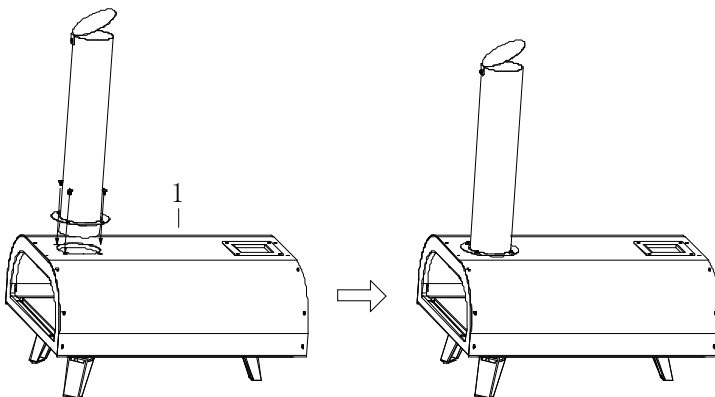
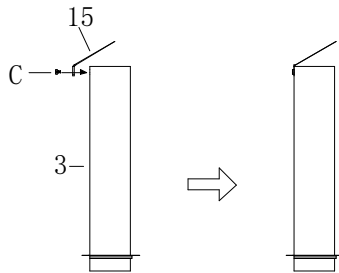

4. Assemble the pellet inlet (part 7) onto the pizza oven body (part 1) as shown. Use the Bolt C to tighten it.

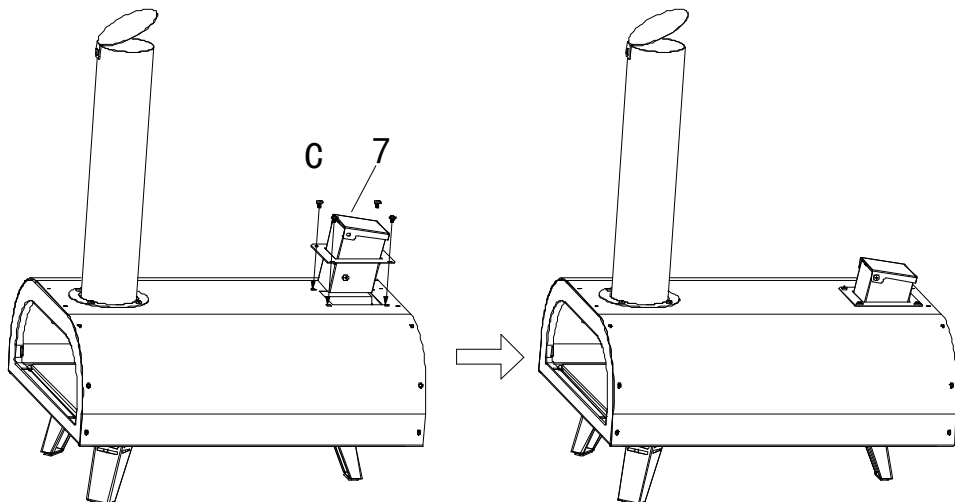

5. Assemble the temperature barrier (part 14) onto the pizza oven body (part 1) as shown. Use the Bolt

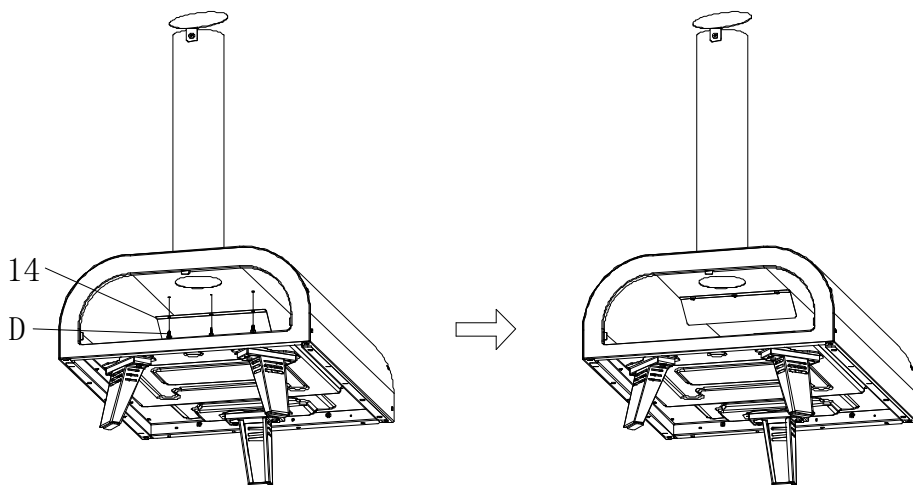

6. Assemble the door handle cover (part 11) onto the Door (part 4) as shown. Use the Bolt F to tighten it.  
Assemble the Thermometer cover (part 12) onto the Door (part 4) as shown. Use the Bolt G to tighten it.

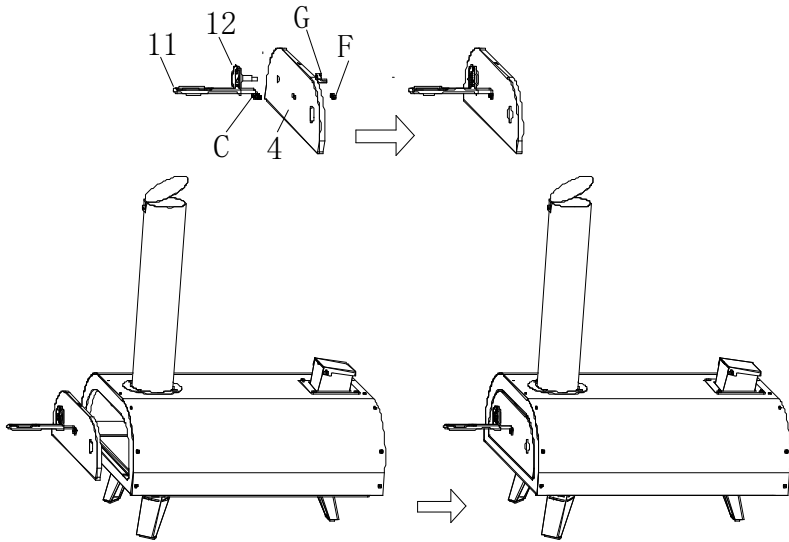

7. Assemble the Pellet box handle cover (part 8) onto the Pellet box (part 5) as shown. Use the Bolt E to tighten it.

Assemble the Pellet box grate cover (part 13) onto the Pellet box (part 5)

Assemble the Pellet shovel handle cover (part 9) onto the Pellet shovel (part 10) as shown. Use the Bolt A to tighten it.

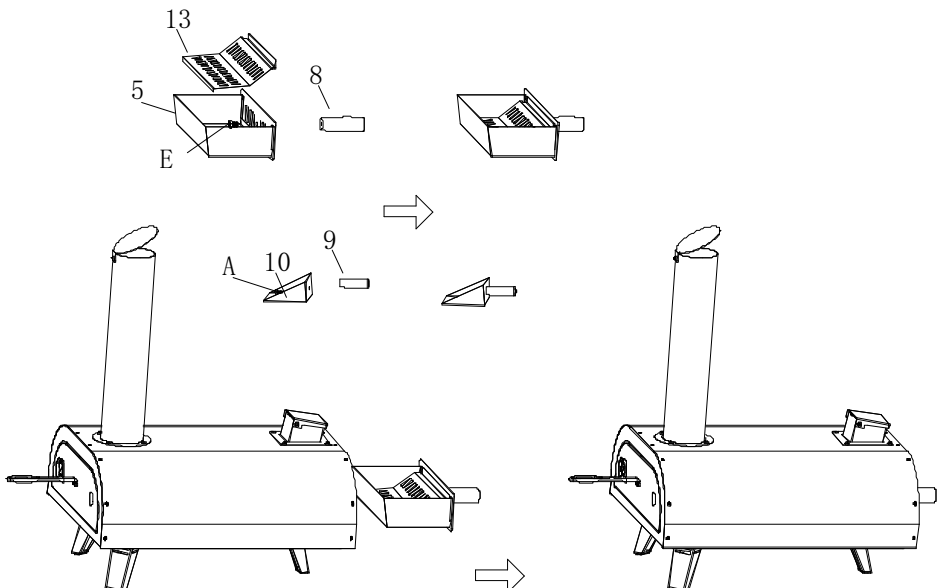

8. Assemble the Pizza stone cover (part 2) onto the Pizza oven body (part 1) as shown.

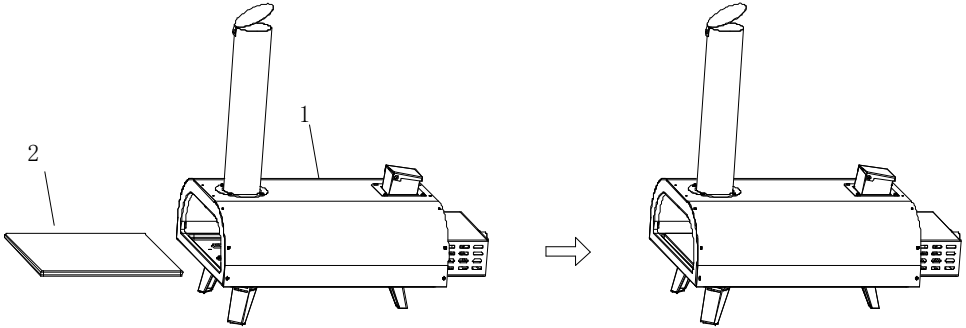

### How to use the pizza oven

1. Use around 400g pellet put into the carbon box.
2. Use flame gun to burn the pellet, around 2-3 mins, the pellet will be burned.
3. If make the pizza, put the pizza stone in the inner, preheat 15 mins. Put pizza inside, 60 seconds turn around, base on the pizza thickness to burner more 90 to 120seconds.
4. Use BBQ function, Preheat 5 mins, prepare the food in the tin pot, Put the food inside, base on different food to turn around it.

### Replenishing the pellet

- During cooking, keep the pellet in hopper assembly at more than half the capacity of the hopper assembly.
- To replenish the pellet during use, use the handle to open the hopper assembly lid, then use the hopper shovel to take some pellets and pour them into the hopper assembly. Place the hopper assembly lid back on the hopper assembly with the handle.
- Make sure oven gloves or mitts are used.

### Remark:

- when you cook around 20mins later, have better to add some more pellet in the carbon box.
- Take out a little of the carbon box.
- Please dispose all plastic bags carefully and keep it away from children.
- Always use heat resistant gloves when handling the product.
- Use flame gun to make fast burn again.
- Take a few moments to familiarize yourself with the contents & before starting check all holes are clear of any paint residue.

### Water:

- Water can damage the inside of your oven. You must ensure that no

water enters the oven chamber, either through the oven door opening, or through the chimney.

- Always place the provided metal door in the oven opening when not in use to stop water from entering through the opening into the oven chamber.

- Do not install the oven at a backward-leaning angle, where water could enter the oven and pool, causing damage.

- Do not ice or wet-mop the oven floor.

Water is not required to clean the cooking floor, The oven operates at very high temperatures. The high heat act as an automatic "self-cleaning" mode, burning off all spilled or stuck-on foods. If stuck-on food is a problem during cooking, you can remove it with a brass oven brush As a preventative measure, nondough based foods should always be placed on appropriate cookware before being placed in the oven.

### **Maintenance and Cleaning Instructions:**

CAUTION: All cleaning and maintenance should be carried out when the pizza oven is cool.

### **OUTSIDE SURFACE**

Use mild detergent or baking soda and hot water solution. Non-abrasive scouring powder can be used on stubborn stains, then rinse with water. If the inside surface of the pizza oven lid has the appearance of peeling paint, baked on grease build-up has turned to carbon and is flaking off. Clean thoroughly with strong hot soapy water solution. Rinse with water and allow to completely dry. NEVER USE OVEN CLEANER.

### **INTERIOR OF BARBECUE BOTTOM**

Remove residue using brush, scraper and/or cleaning pad then wash with a soapy water solution.

Rinse with water and allow to dry.

### **COOKING GRID**

Use a mild soapy water solution. Non-abrasive scouring power can be used on stubborn stains then rinse with water.

### **INTERIOR OF BARBECUE BOTTOM**

Remove residue using brush, scraper and/or cleaning pad then wash with a soapy water solution Rinse with water and allow to dry. it should be clean the carbon deposition after use.

### **WARNING!**

Danger of suffocation! The oven is intended for outdoor use only. It must not be used in building, garages or other closed areas. Toxic fumes may form, which can lead to suffocation.

**Caution:** Do not open the granule access cover directly with hands during operation. Always use a shovel or other appropriate tools to open the cover.

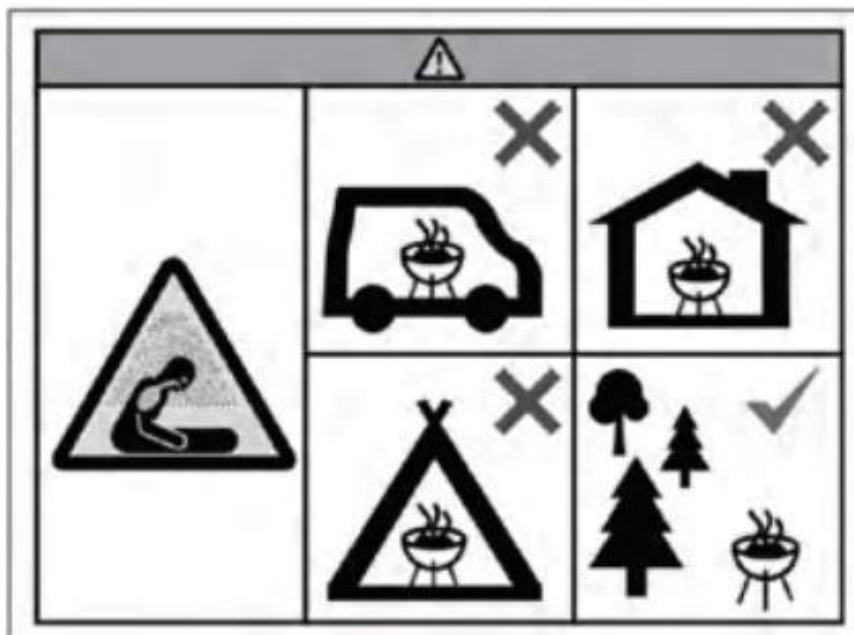
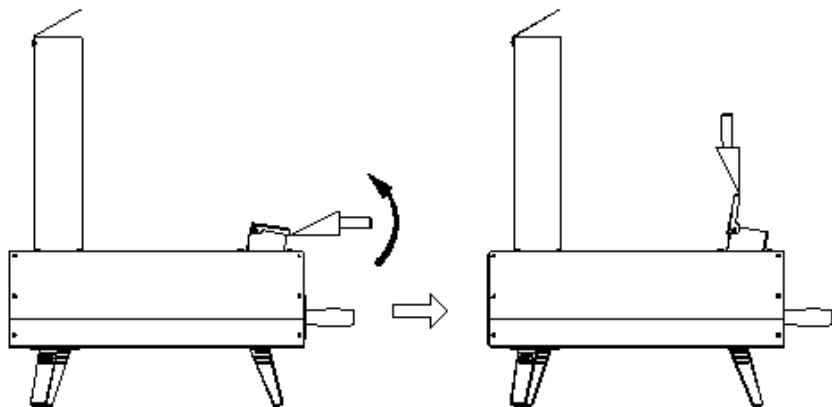

## Reference cookbook:

For reference (adjust the time for different thickness)	
Food	Time
Pizza(thin)	1-2 mins
Steak	3 mins (medium)
Sausage	4 mins
Pork	6 mins
Sheep frame	6 mins
Chicken wing	6 mins
Bread	15 mins

## IMPORTANT SAFETY INSTRUCTIONS



### WARNING

#### **Hazardous fire or explosion may result if instructions are ignored**

It is the consumer's responsibility to see that the barbecue is properly assembled, installed, and taken care of. Failure to follow instructions in this manual could result in bodily injury and/or property damage.

- Read the instructions before using the pizza oven.
- Retain this use & care guide for future reference
- Use outdoors only.
- Warning accessible parts may be very hot. Keep young children away.
- Do not move the pizza oven during use.
- Do not modify the pizza oven.
- This pizza oven must be kept away from flammable materials during use. The pellet will be very hot so take suitable precautions.
- Do not leave the handle on the pizza oven.
- Never touch metal parts that may be hot.
- Do not cook before the fuel has a coating of ash.

### **General Safety Guidelines**

#### **Must be read in full prior to use**

Please read the general safety guidelines fully before assembling, installing and using/servicing your pizza oven. Failure to comply with all the provisions of the present legal disclaimer could result in property

damage, serious bodily injury or even death.

1. Pizza oven is designed for outdoor use only. The pizza oven must always be placed outdoors, away from structures and never inside a building or a garage or in proximity to any enclosed area. Place your pizza oven on a sturdy, level, stable and non-flammable surface and keep it clean and free from flammable or combustible materials, gasoline and other flammable vapors and liquids.

2. Be aware of any local laws or regulations that may specify a required distance between outdoor cookers and any structures, or that may limit outdoor flame of any type during drought or hazard periods.

3. Do not install or use your pizza oven in or on boats or recreational vehicles.

4. Do not use your pizza oven in high winds.

5. Your pizza oven is not intended to, and should never be used as a heater.

6. Toxic fumes can accumulate and may cause asphyxiation.

7. Flames can blow outside of the metal enclosure: a. at the back where the fire is;

b. from the top of the hatch when the lid is opened; c. from the front of the oven when you open the door; or

d. from the top of the chimney.

8. Please keep away from the pizza oven's openings and warn others around you.

9. Improper installation, adjustment, alteration, service or maintenance of your pizza oven may cause injury or property damage. Therefore, do not use your pizza oven unless it is completely assembled and all parts are securely fastened and tightened.

10. When using the pellet burner:

The length of pellets used can greatly affect the temperature of your pizza oven. The recommended pellet length should be no longer than 1.25" (3cm). Longer pellets have a slower feed rate which can cause your pizza oven to burn colder. When changing or refilling pellets be aware of the average length and adjust your pizza oven setting accordingly. Only use pellets intended for use in cooking.

11. When using the charcoal/wood burner: Add the kindling gradually to reach an optimum temperature. Adding too much kindling will enlarge the fire, risking damage to you or your pizza oven.

12. When using your pizza oven, there is a risk for your hands to be burned. Protective heat resistant gloves should be worn at all times to avoid burns and you should never set hot items on or near combustible surfaces. DO NOT touch any metal parts when your pizza oven is operating. Only touch the wooden handles to open the door and lift the fuel

hatch.

13. Never leave your pizza oven unattended. Do not leave your pizza oven unattended with the lid open while lit. Be aware of hazards (dry leaves, decking and other combustible materials) that may be in proximity to the pizza oven while it is in use as they may present a fire hazard if any sparks are allowed to come into contact.

14. Keep all electrical cords away from your pizza oven. Pizza oven (when being used) ranges from 100°F (50 °C) to 1200°F (650 °C).

15. Pizza oven is safe and hazard free when used as intended and according to safety guidelines and will provide years of trouble-free use and enjoyment. It is the user's responsibility to maintain safe operation of the pizza oven and to exercise reasonable standards of care at all times.

16. Whilst every effort has been made in the manufacture of your barbecue to remove any sharp edges, you should handle all components with care to avoid accidental injury.



## **WARNING**

### **NOTE FOR CONSUMER: Retain for future Reference**

This pizza oven is designed for use outdoors, away from any flammable materials. It is important that there are no overhead obstructions and that there is a minimum distance of 122cm (4 ft.) from the side or rear of the appliance. It is important that the ventilation openings of the appliance are not obstructed. The barbecue must be used on a level, stable surface. The appliance should be protected from direct draughts and shall be positioned or protected against direct penetration by any trickling water (e.g. rain).

### **Clean the Pizza Stone**

Cleaning pizza stone is the trickiest part of cleaning a pizza oven. While it does not really need cleaning, if cleaned without care, you could end up damaging the pizza stone.

- **Preheat or burning after the baking session:** To get rid of the bits and pieces stuck to the pizza stone, you can consider heating it for a few minutes after the baking session. It will burn off those bits into ashes—cleaning the stone. The preheating before the baking is often enough to rid the stone of the stuck bits.
- **Light brushing:** While preheating is ample, consider lightly brushing the pizza stone with an old but clean towel if you want to go the extra mile.
- **Wiping with a damp cloth:** Briefly wipe the surface of the pizza stone with a damp washcloth. Do not soak the cloth or sponge in water. Use

only a little water. And let the stone completely air dry before putting it back to work.

**Caution:** Never soak the pizza stone in water or rinse it under running water. Also, never use any detergent or cleaning agent on the pizza stone.

**IMPORTANT REMINDER**

Please make sure the door is closed during baking except when putting or fetching food, otherwise fire may come out from the back of oven and it's hard to keep the baking temperature inside oven.

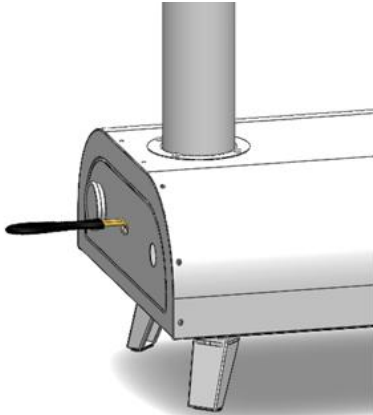

✓ YES

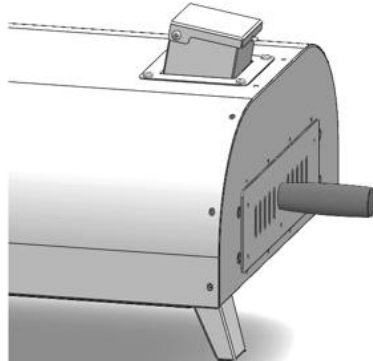

✓ YES

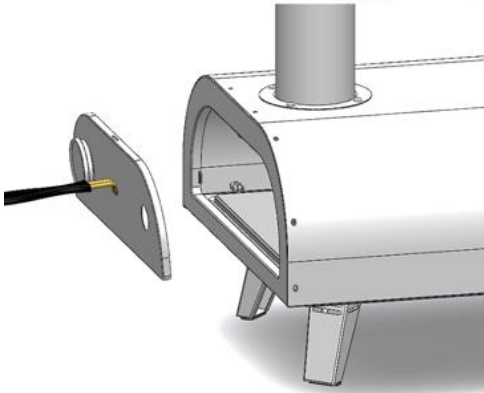

✗ NO

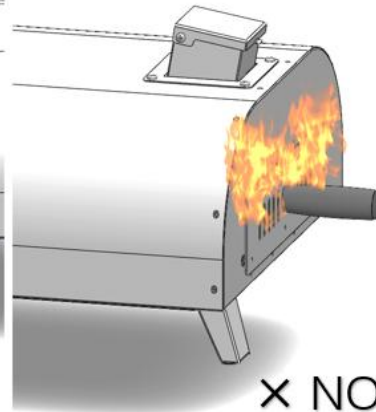

✗ NO

**Manufacturer:** Shanghaimuxinmuyeyouxiangongsi

**Address:** Shuangchenglu 803nong11hao1602A-1609shi, baoshanqu, shanghai 200000 CN.

**Imported to AUS:** SIHAO PTY LTD. 1 ROKEVA STREETEASTWOOD NSW 2122 Australia

**Imported to USA:** Sanven Technology Ltd. Suite 250, 9166 Anaheim Place, Rancho Cucamonga, CA 91730

<b>UK</b>	<b>REP</b>
-----------	------------

YH CONSULTING LIMITED. C/O YH Consulting Limited Office 147, Centurion House, London Road, Staines-upon-Thames, Surrey, TW18 4AX

<b>EC</b>	<b>REP</b>
-----------	------------

E-CrossStu GmbH  
Mainzer Landstr.69,  
60329 Frankfurt am Main.

