

**RX Series 19 in W x 25 in D Powder Coated Steel
3 Drawer & 3 Shelf Side Locker**

**Model:
RX192503SL**

Extreme Tools, Inc.
740 Frontenac Road
Naperville, Illinois 60563
630.369.9303
www.ExtremeTools.net

Side Locker Parts List RX192503SL

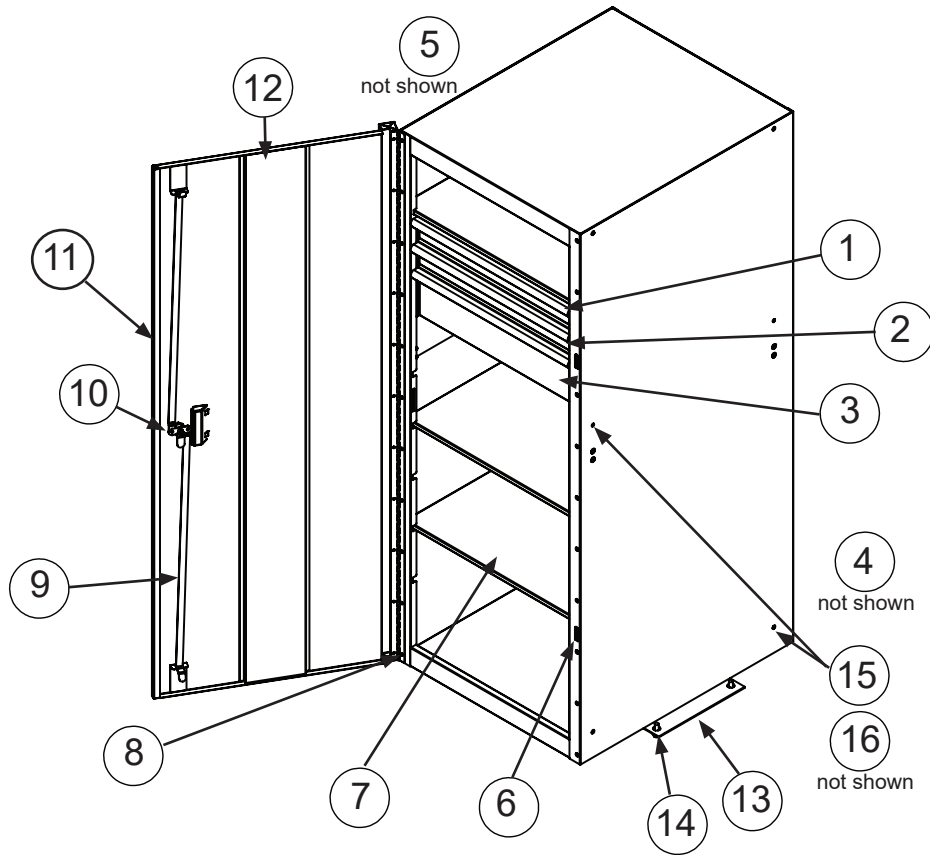

Replacement keys may be ordered using the code that appears on the face of the lock.

To order replacement parts, have the part number, tool box color and quantity ready.

If under warranty, the serial number is **REQUIRED** to get replacement parts.

Not all parts are available under warranty and may be purchased separately.

PARTS LIST - RX192503SL

ITEM NO	PART NUMBER	DESCRIPTION	QTY
1		SL25 BODY	1
2	ZDRR398E1NWGK	RX1925SL Drawer 398 mm Wide, 100 Lb. Slides, Single Deep, Green with Black Drawer Pulls.	2
2	ZDRR398E1NWKC	RX1925SL Drawer 398 mm Wide, 100 Lb. Slides, Single Deep, Black with Chrome Drawer Pulls.	2
2	ZDRR398E1NWKR	RX1925SL Drawer 398 mm Wide, 100 Lb. Slides, Single Deep, Black with Red Drawer Pulls.	2
2	ZDRR398E1NWKU	RX1925SL Drawer 398 mm Wide, 100 Lb. Slides, Single Deep, Black with Blue Drawer Pulls.	2
2	ZDRR398E1NWMK	RX1925SL Drawer 398 mm Wide, 100 Lb. Slides, Single Deep, Matte Black with Black Drawer Pulls.	2
2	ZDRR398E1NWOK	RX1925SL Drawer 398 mm Wide, 100 Lb. Slides, Single Deep, Orange with Black Drawer Pulls.	2
2	ZDRR398E1NWUC	RX1925SL Drawer 398 mm Wide, 100 Lb. Slides, Single Deep, Blue with Chrome Drawer Pulls.	2
2	ZDRR398E1NWUK	RX1925SL Drawer 398 mm Wide, 100 Lb. Slides, Single Deep, Blue with Black Drawer Pulls.	2
3	ZDRR398E2NWGK	RX1925SL Drawer 398 mm Wide, 100 Lb. Slides, Double Deep, Green with Black Drawer Pulls.	1
3	ZDRR398E2NWKC	RX1925SL Drawer 398 mm Wide, 100 Lb. Slides, Double Deep, Black with Chrome Drawer Pulls.	1
3	ZDRR398E2NWKR	RX1925SL Drawer 398 mm Wide, 100 Lb. Slides, Double Deep, Black with Red Drawer Pulls.	1
3	ZDRR398E2NWKU	RX1925SL Drawer 398 mm Wide, 100 Lb. Slides, Double Deep, Black with Blue Drawer Pulls.	1
3	ZDRR398E2NWMK	RX1925SL Drawer 398 mm Wide, 100 Lb. Slides, Double Deep, Matte Black with Black Drawer Pulls.	1
3	ZDRR398E2NWOK	RX1925SL Drawer 398 mm Wide, 100 Lb. Slides, Double Deep, Orange with Black Drawer Pulls.	1
3	ZDRR398E2NWUK	RX1925SL Drawer 398 mm Wide, 100 Lb. Slides, Double Deep, Blue with Black Drawer Pulls.	1
3	ZDRR398E2NWUC	RX1925SL Drawer 398 mm Wide, 100 Lb. Slides, Double Deep, Blue with Chrome Drawer Pulls.	1
4	ZSLW530F230	DRAWER SLIDE SET - 100 LBS	3
5	Z-LK-EX01-EX04	RX series lock and key set, EX01- EX04	1
6	Z-MT312033	MAGNET CATCH (RECTOANGLULAR)	2
7	Z-RX1925SL-09BK	Shelf for RX1925SL, Black	2
7	Z-RX1925SL-09BL	Shelf for RX1925SL, Blue	2
7	Z-RX1925SL-09MB	Shelf for RX1925SL, Matte Black	2
7	Z-RX1925SL-09OR	Shelf for RX1925SL, Orange	2
8	Z-MSM4-8MM	M4-0.7X8MM FH METAL SCREW	11
9	RX1921SL-12	LOCKING BAR	2
10	Z-PDP	BLACK DOOR PULL	1
11	ZTRR1543C	RX 19, 24 series Side Locker Trim,1543mm Chrome finish.	1
11	ZTRR1543K	RX 19, 24 series Side Locker Trim,1543mm Black finish.	1
11	ZTRR1543R	RX 19, 24 series Side Locker Trim,1543mm Red finish.	1
11	ZTRR1543U	RX 19, 24 series Side Locker Trim,1543mm Blue finish.	1
12	ZDORX1925SL-BKBL	RX192503SL door Assy. Black w/ Blue	1
12	ZDORX1925SL-BKCR	RX192503SL door Assy. Black w/ Chrome	1
12	ZDORX1925SL-BKRD	RX192503SL door Assy. Black w/ Red	1
12	ZDORX1925SL-BLBK	RX192503SL door Assy. Blue w/ Black	1
12	ZDORX1925SL-BLCR	RX192503SL door Assy. Blue w/ Black	1
12	ZDORX1925SL-GNBK	RX192503SL door Assy. Green w/ Black	1
12	ZDORX1925SL-MBBK	RX192503SL door Assy. Matte Black w/ Black	1
12	ZDORX1925SL-ORBK	RX192503SL door Assy. Orange w/ Black	1
12	ZDORX1925SLBLCR	RX192503SL door Assy. Blue w/ Chrome	1
13	RX1921SL-15	RX SL/SB Bottom support bracket w/ screws	1
14	ZM8WAFT-BK	M8 flat washer, Black	2
14	ZM8WAFT-BL	M8 flat washer, Blue	2
14	ZM8WAFT-GN	M8 flat washer, Green	2
14	ZM8WAFT-MK	M8 flat washer, Matte Black	2
14	ZM8WAFT-OR	M8 flat washer, Orange	2
15	ZM8SCHX-16 BK	M8X16 Hex Bolts, Black	2
15	ZM8SCHX-16 BL	M8X16 Hex Bolts, Blue	2
15	ZM8SCHX-16 GN	M8X16 Hex Bolts, Green	2
15	ZM8SCHX-16 MB	M8X16 Hex Bolts, Matte Black	2
15	ZM8SCHX-16 OR	M8X16 Hex Bolts, Orange	2
16	Z-CLIPDX203902	Shelf clip for the DX side locker, RX side locker	4



RX Series 19-in W Side Locker - Installing Mounting Bracket



WARNING: SIDE LOCKER IS HEAVY! ASSISTANCE IS NEEDED TO INSTALL SIDE LOCKER.

Follow OSHA guidelines for lifting/hoisting heavy objects.

WARNING!!! LOCK CASTERS ON ROLLER CABINET BEFORE PROCEEDING!

Wear gloves to avoid injury. Metal strapping and packaging edges may be sharp.

1. Lay a soft mat or other soft surface on the ground to protect the bottom of side locker when it is removed from packaging.



2. Remove the side locker packaging by lifting MDF crate off the side cabinet.

WARNING! HEAVY LIFT - ASSISTANCE REQUIRED: CRATE IS HEAVY!

Assistance needed to remove packaging safely!

3. Next, remove the cardboard carton packaging and protective cover from the side cabinet.

4. **CABINET is HEAVY!!!** With assistance, stand the side cabinet on the soft surface so that it is in an upright position near the roller cabinet.



5. Install the bottom bracket onto the underside of the roller cabinet on the side where side locker will be installed. Use two M4 screws to install. **HAND TIGHTEN ONLY!** Bracket should be a little loose (approximately an 1/8" of play) to leave room to adjust bracket to engage and attach locker.

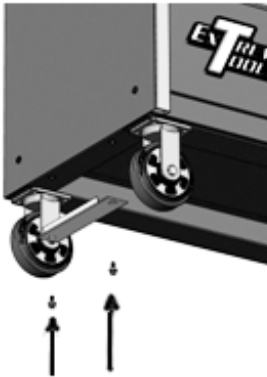

Install bracket under roller cabinet using M4 screws

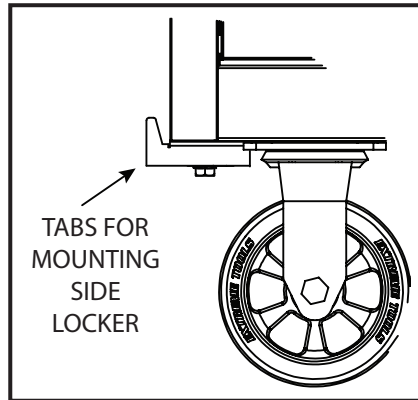

TABS FOR MOUNTING SIDE LOCKER



Mounting bracket installed loosely on roller cabinet.



Support bracket shown under roller cabinet attached with bolts



Align holes of side locker with side locker holes.



6. Mount side cabinet on bracket and attach to tool box:

CABINET IS VERY HEAVY!

ASSISTANCE IS NEEDED to prevent injury or damage to mount the side locker!

With assistance, lift the side locker and tilt slightly away from the side of the roller cabinet to engage the protruding curved lip of the bottom mounting bracket which is attached under the roller cabinet. Straighten into upright position being sure to align the holes inside the side locker to holes on roller cabinet. Make sure the bottom of the side locker and roller cabinet are aligned.

7. With one or more persons holding the cabinet in place, from inside the locker, install four (4) metal screws. Hand tighten.
8. If hutch is installed on roller cabinet, repeat step 7 to fasten screws through side locker into the hutch.
9. Once all screws are installed use a socket ratchet to securely tighten.
10. **VERY IMPORTANT! Securely tighten all screws. Use socket ratchet to securely tighten bottom support bracket which is installed under roller cabinet and side locker from Step 5 & 6!**



From inside the locker, install screws and hand tighten.

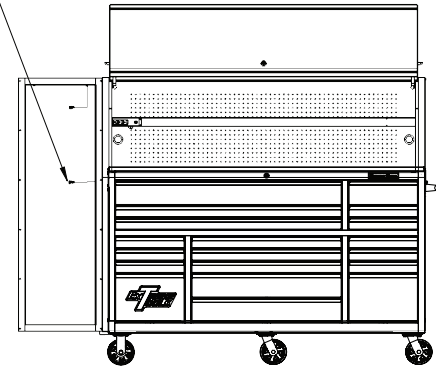

OPERATING PROCEDURE

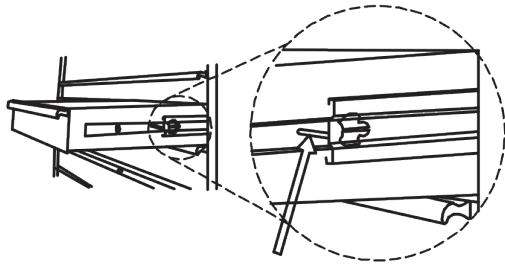

Drawer Removal

Pull drawer out so that it is almost fully extended.

Push up on the black lever on one drawer slide and at the same time push down on the lever on the other side.

With the levers in these positions, pull the drawer out until it releases from the drawer slides.

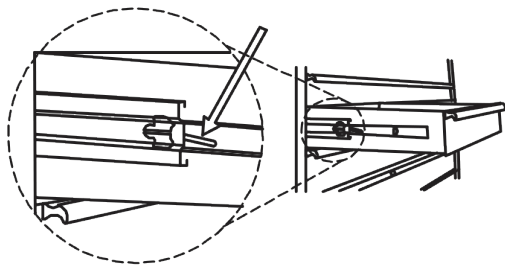

Drawer Replacement

Extend the drawer slides.

Carefully align the brackets on the sides of the drawers with the slots of the cabinet slides. Insert the brackets on the side of each drawer into the slots of the cabinet slides.

Once properly inserted, completely close the drawer to set the slides into their properly functioning positions.

MAINTENANCE

Check and tighten bolts attaching side locker to roller cabinet on a regular basis.

Wear safety glasses and lubricate the slides twice a year with high quality, petroleum-based lubricant. This may be required more often if operating the tool box in colder climates.

Use mild detergent and water to clean drawer fronts, drawer trim and other surfaces.

Grease and oil can be removed with standard, non-abrasive, non-flammable cleaning products.

Auto wax will help preserve the unit's high gloss finish. Follow directions as provided.

SAFETY



WARNING

Do not attempt to lift the cabinet by its side handle using chains, ropes or lifting device.

Side handle may fail resulting in personal injury or damage to the product!

Use a forklift or similar lifting device with forks placed under the bottom of the tool box to move if tool box cannot be moved by two people.

Close the drawers and lock the tool box before moving this product! If drawers are not locked they could open and make the product unstable and tip which may cause personal injury or damage to the product.

Do NOT stand on this product or lean on the drawer or work top.

Wear safety glasses when removing or repositioning the slides. The tool box could slip resulting in personal injury.

Do NOT mount this product on a truck bed or other moving object. This may cause personal injury or product damage. Mounting this product on any surface will void the warranty.

Do NOT tow with power equipment. The product could tip which may cause personal injury or product damage.

Do NOT alter this product in any manner or attach electrical equipment. This may cause personal injury or product damage and will void the warranty.

If using the combination top chest/hutch and roller cabinet, the top chest/hutch MUST be secured to the roller cabinet by following the directions provided. Not securing the top chest/hutch to the roller cabinet may cause the product to become unstable which may cause personal injury or damage to the product.



CAUTION - IMPORTANT PRODUCT INFORMATION

DRAWERS MUST BE CLOSED AND TOOL BOX LOCKED USING KEYS BEFORE MOVING!

The maximum weight for each drawer should not exceed 100 lbs. (45 kg) for single slides and 200 lbs. (90kg) for drawers with double slides.

Use caution when closing the door. Remove hands from the area before closing to prevent personal injury.

Do NOT pull this product. Push the product to prevent personal injury.

ENGAGE THE BRAKES on roller cabinet when not moving this product. Locked casters prevent the product from rolling which may result in personal injury or damage to the product.

This product may become unstable and tip if more than one drawer is open at a time. To prevent personal injury or damage to product, OPEN ONLY ONE DRAWER AT A TIME.

Lock product and properly secure before moving with a forklift or other device.

Keep the product on a level surface. The product could become unstable and tip if stored or moved on an uneven surface which may result in personal injury or product damage.

Remove the work surface from the roller cabinet before installing top chest.