

# ASSEMBLY/PRE-RIDE INSPECTION INSTRUCTIONS

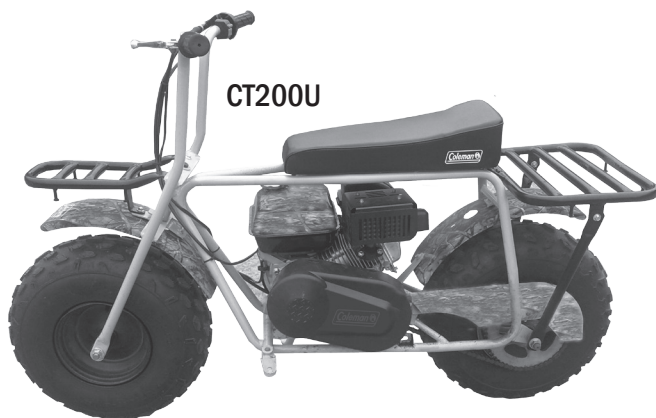

Mini bike may have oil in it when shipped from the factory. However, it is a good idea to drain this oil and replace with new SAE 10W-30 Motor Oil before starting the engine for the first time.

For questions about these Assembly Instructions, call Coleman Powersports toll free 888-405-8725

## **▲ WARNING**

Never attempt to start this Mini Bike without reading and understanding the Owner's/Operator's manual. The Owner's/Operator's manual provides information on safety, parts, functions, pre-ride inspection, starting and maintenance.

# REMOVAL FROM CRATE

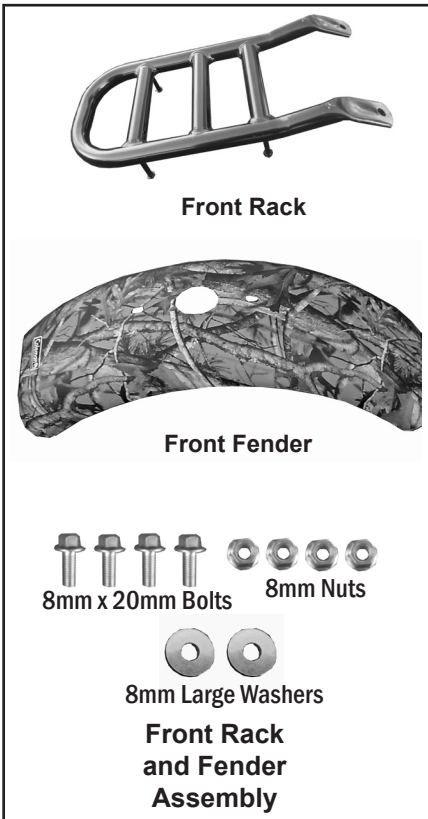
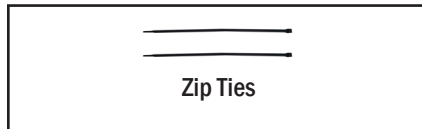
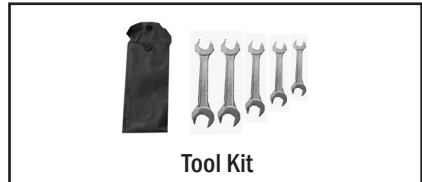
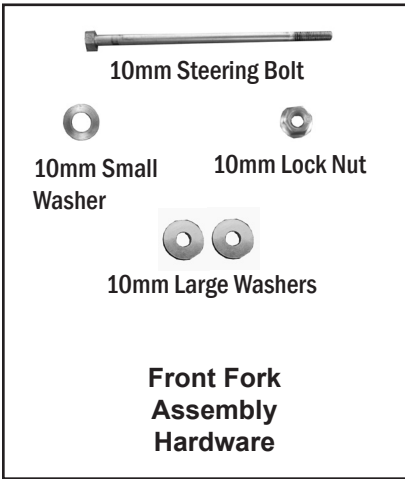

# FRONT FORK INSTALLATION

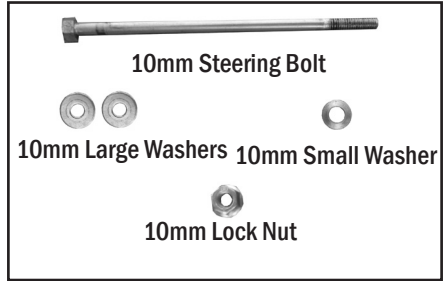

1. Install front Fork Assembly by inserting the 10mm steering bolt through the assembly in the following order:

Top bracket, Small 10mm Washer, Steering Neck, Large 10mm Washer, Bottom Bracket, Large 10mm Washer, Lock Nut

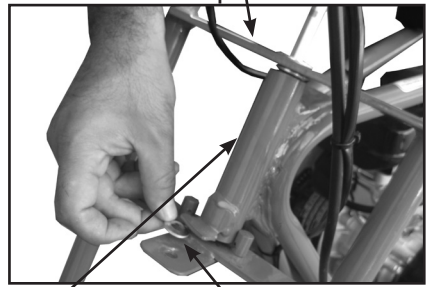
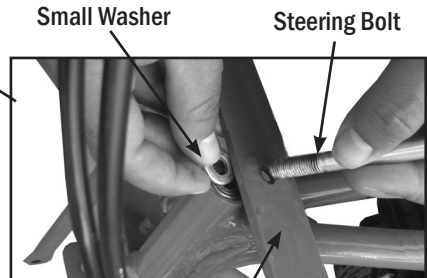

2. Tighten nut  
Torque nut to 30 ft .lbs. ( 41Nm)

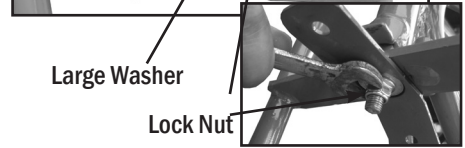
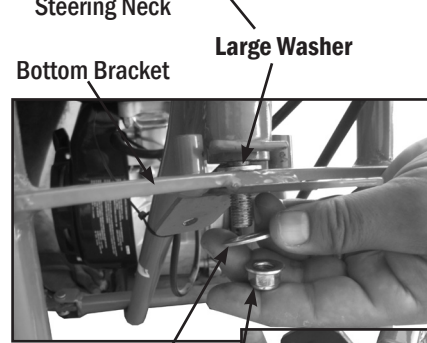

# FRONT RACK AND FENDER INSTALLATION

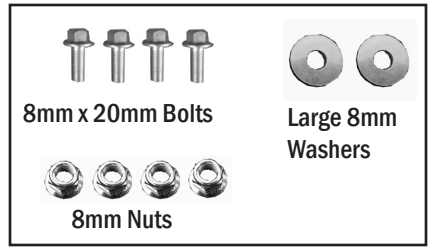

1. Attach the Front Rack to the Steering Column Assembly using 8mm x 20mm bolts, and 8mm nuts

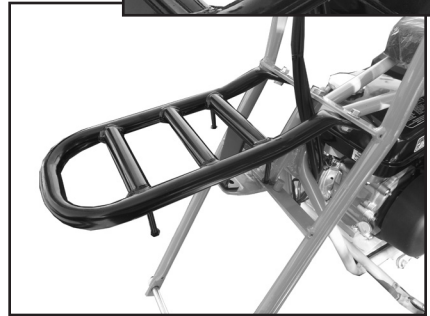
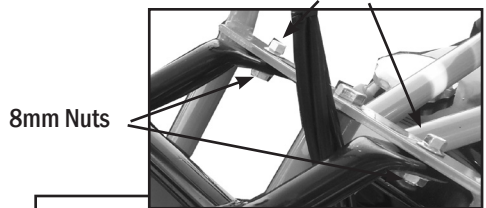

2. Attach front fender with 8mm x 20mm bolts, large 8mm washers and 8mm nuts.

Note: Small portion of fender faces forward

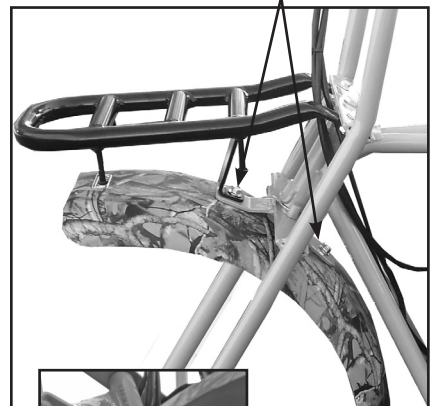

# FRONT WHEEL INSTALLATION

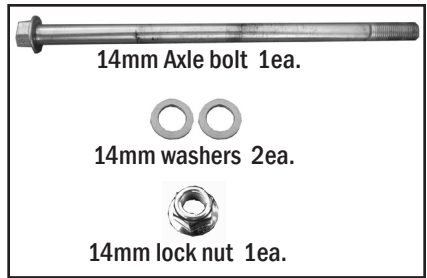

1. Orient the front tire so the arrow on the tire faces forward.

2. Insert Axle bolt with the 14mm washers between the forks and wheel assembly on each side.

3. Install 14mm lock nut and tighten.

Torque Front Lock Nut 30 ft.lbs (41Nm)

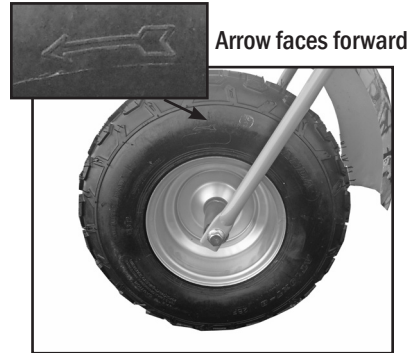

14mm Washer

14mm Axle Bolt

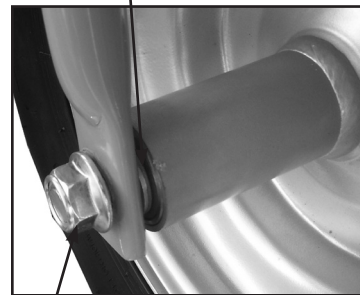

14mm Lock Nut

# SECURE WIRES AND CABLES

## INSTALL CLUTCH COVER

1. Make sure the On/Off Switch wire, Throttle cable and Brake cable are not kinked and have free movement when the handle bars are turned from left to right.



Zip Ties

2. Secure wires and cables to frame using the Zip ties provided.

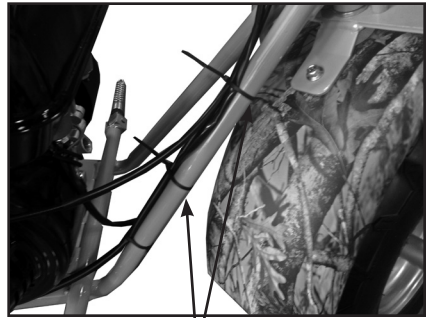

Zip Ties

3. Install clutch cover over the 4 bracket tabs provided on the clutch assembly. Make sure the clutch cover is attached securely.

Clutch Cover

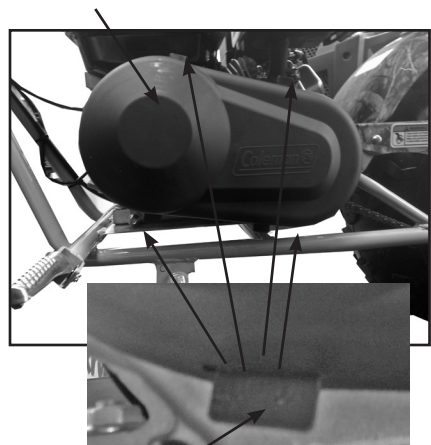

Bracket Tabs

# OIL AND FUEL

## Engine Oil

Mini bike may have oil in it when shipped from the factory. However, it is a good idea to drain this oil and replace with new SAE 10W-30 Motor Oil.

### Changing the engine oil

1. Remove the oil fill plug (1)
2. Remove the drain bolt (2) located on the bottom of the engine.
3. Allow the oil to drain in an appropriate container. Note: Dispose of oil at an oil recycle center.
4. Install the drain plug and fill with SAE 10W-30 motor oil. This mini bike takes .63qt. (.6L) of engine oil. Oil should be up to the brim of the fill hole.
5. Re- install fill cap, Start engine and allow to run for a few minutes, Re-check oil level and fill accordingly.

**Caution:** Do not over or under fill with Motor Oil

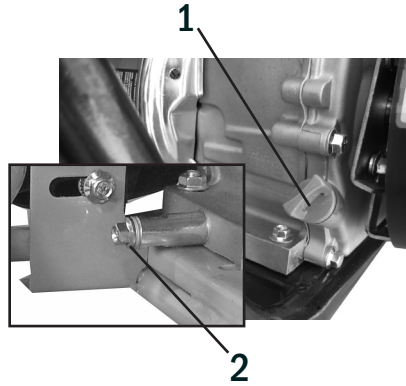
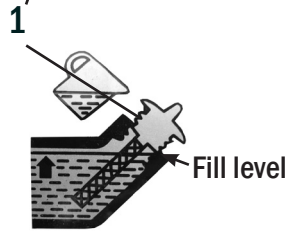
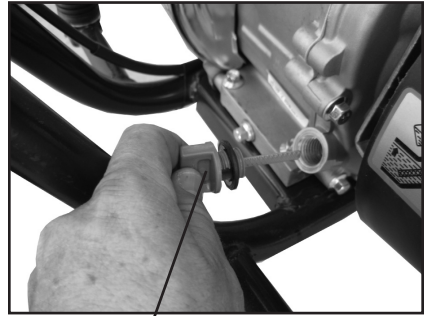

## FUEL

Never use leaded gasoline in this product. It could affect the engine's emissions and damage the engine.

Mini Bike requires clean unleaded regular gasoline with a minimum octane rating of 86 or higher.

Fill with gasoline up to the bottom of the filler neck.

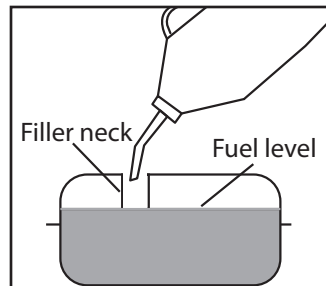

# TIRE PRESSURE

## Tires

1. Check tire pressure. Incorrect tire pressure can affect the handling, rider comfort, steering, tire life and traction. Always check the tire pressure before each ride.



### Tire pressure

Front tires: 10psi

Rear tires: 10psi

## Chain tension

Check the tension of the chain , The chain (1) tension should be 1/2 - 3/4 in. (15-20mm)

### Chain tension (slack) adjustment

1. Loosen bolt (2) on the rear axle assembly.
2. Adjust chain tension by turning the tension nuts (3) (Note: Tension nuts are located on both sides of the mini bike.) Clockwise will tighten the chain. Counter clockwise will loosen the chain.
3. Once the chain is at the correct tension re-tighten axle bolt (2).
4. Re-check chain tension.

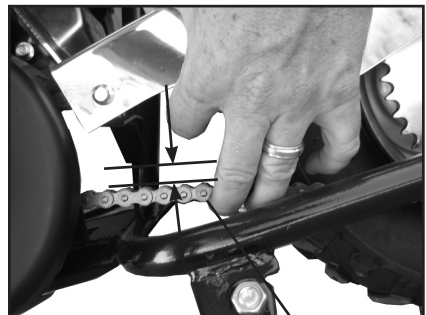

1/2 - 3/4 in.  
(15-20mm)

1

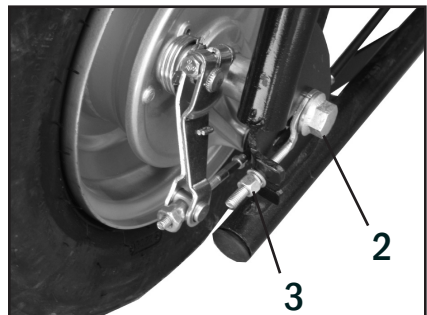



# BRAKE ADJUSTMENT

## Brakes

### Brake Lever Adjustment

The front left brake lever (1) should have 2.0 - 4.0mm (0.08 - 0.16) of free play.

To adjust brake lever free play:

1. Loosen the jam nut (2) on the brake cable.
2. Turn the adjuster nut (3) until the correct amount of free-play is achieved.
3. Re tighten jam nut (2)

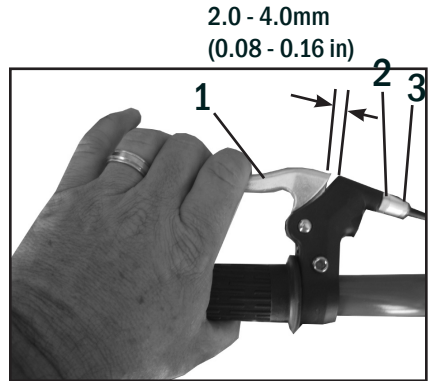

### Brake Adjustment

To adjust brakes, loosen the rear axle bolt (4)

Locate the adjustment nut (5) located on the rear brake drum assembly.

To adjust brakes, turn the adjusting nut (5) clockwise to increase braking, counter clockwise to decrease braking.

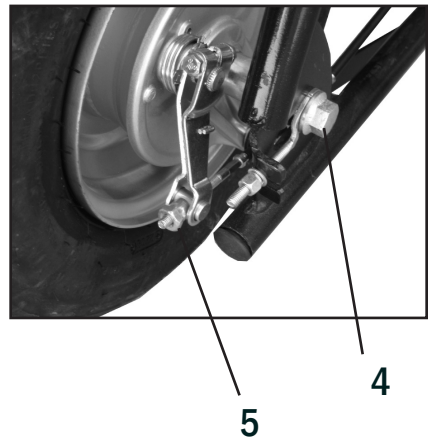

# THROTTLE ADJUSTMENT

## Idle speed adjustment

The idle speed should be set at  $1700 \pm 150$  RPMs

Note: A service center can perform this adjustment . A diagnostic tachometer is required for this adjustment.

To adjust the idle speed:

1. Locate the idle adjustment screw (1) located on the carburetor.
2. Allow the engine to warm up approximately 10 minutes
3. With the engine running, turn the idle adjustment screw in or out at small increments until the correct idle is achieved.

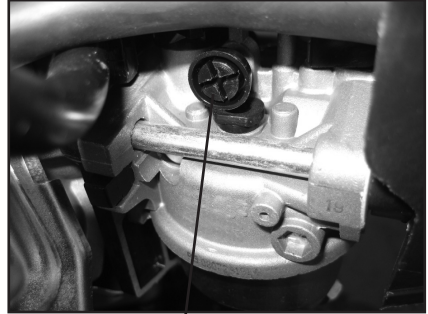

1

## Throttle Cable adjustment

It is important that the throttle grip have a certain amount of free play .

The hand grip throttle free play (2) should be  $.078 - .24$  in (2-6 mm)

To adjust freeplay

1. Loosen jam nut (3)
2. Turn adjusting nut (4) to proper setting
3. Once throttle grip is at the proper freeplay, re-tighten the jam nut (3).



# PRE-RIDE INSPECTION

Inspecting and checking the condition of the Mini Bike before each ride is important. Following the pre-ride check list will help insure there are no problems which could result in injury or becoming stranded. Make sure the Mini Bike is in good operating condition before each ride.

## WARNING

Failing to inspect and maintain the Mini Bike could be hazardous.

Not following the pre-ride inspection procedures could result in losing control of the Mini Bike resulting in an accident or damage to the Mini Bike

Always perform a Pre-ride inspection before each ride.

## WARNING

Performing maintenance and checks while the engine is running could be hazardous.

You could be severely injured by moving parts or hot surfaces.

Never perform maintenance or check procedures while the engine is running with the exception of checking the engine stop switch or throttle.

WHAT TO CHECK	CHECK FOR
Steering	<ul style="list-style-type: none"> <li>• Smoothness</li> <li>• No restriction of movement</li> </ul>
Brakes	<ul style="list-style-type: none"> <li>• Proper brake lever play</li> </ul>
Tires	<ul style="list-style-type: none"> <li>• Proper tire pressure</li> </ul>
Fuel Tank	<ul style="list-style-type: none"> <li>• Enough fuel for the ride</li> <li>• Fuel cap secure</li> <li>• Hoses have no signs of cracks or leaks</li> </ul>
Throttle grip	<ul style="list-style-type: none"> <li>• Throttle grip snaps back to idle when released</li> <li>• Operates freely</li> <li>• Has correct free play</li> </ul>
Engine Stop Switch	<ul style="list-style-type: none"> <li>• Switch shuts off engine when activated.</li> </ul>
Engine Oil	<ul style="list-style-type: none"> <li>• Correct oil level</li> </ul>
Drive Chain	<ul style="list-style-type: none"> <li>• Proper tension</li> <li>• Lubricated</li> </ul>
General Condition	<ul style="list-style-type: none"> <li>• Cotter Pins on axle</li> <li>• All nuts and bolts tight</li> <li>• No rattles from engine or frame while running</li> </ul>

# STARTING ENGINE

## STARTING ENGINE

To start the engine

1. Place the fuel valve (1) to the “ON” (right) position
- 2.. If engine is cold, place the choke lever (2) to the “ON” (left) position.
3. Place the ON/OFF switch (3), located on the handlebars, to the (on)position.
4. Pull the starter recoil cord to start the engine.
5. Once engine has warmed up for a few minutes, place the choke lever (2) back to the “OFF” (right) position.

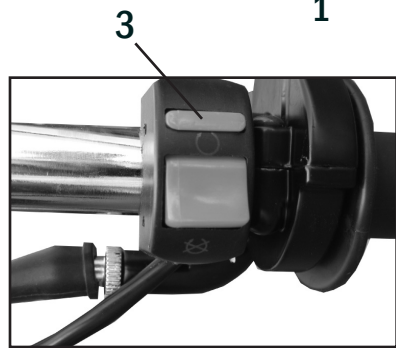
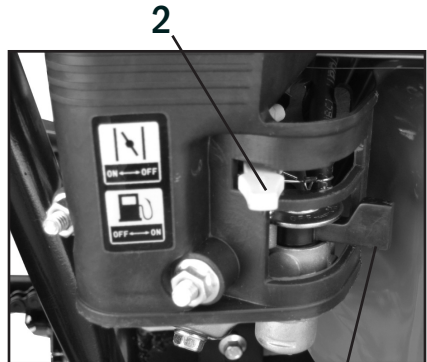

## **⚠ WARNING**

Starting or running the Mini Bike in an enclosed area such as a garage or shed where there is no ventilation is hazardous.

Inhaling exhaust fumes from the Mini Bike can cause severe injury or death.

Never start or run the Mini Bike in an inclosed environment where there is no ventilation. Always start and run outdoors.

**▲ WARNING**

**Never attempt to start this Mini Bike without reading and understanding the Owner's/Operator's manual. The Owner's/Operator's manual provides information on safety, parts, functions, pre-ride inspection, starting and maintenance.**



PHONE: Toll Free 888-405-8725

[colemanpowersportsusa.com](http://colemanpowersportsusa.com)