

OC341300TX
Alden Round Side Table
Assembly Instruction



For assistance with assembly, contact:
Southern Enterprises Inc.
Customer Service 1-800-633-5096
service@seidal.com
www.seidal.com

PO#13440



OC341300TX

Alden Round Side Table

Parts List

Please review all parts and hardware before disposing of any packaging.
Call Customer Service if missing hardware. Do not return to store/retailer.
Using a screw that is too long will cause damage. Before beginning assembly,
separate each type of screw. Carefully study the screw diagrams below.
You may receive extra hardware with your unit.

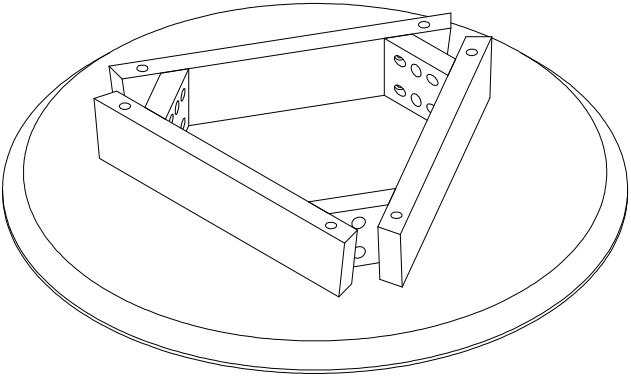
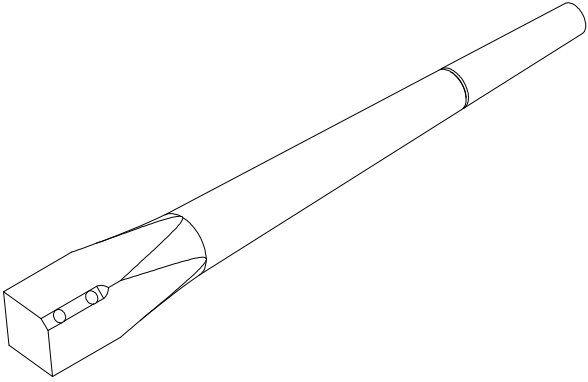
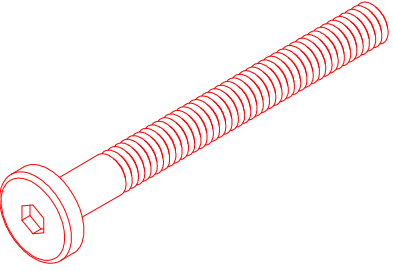
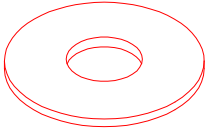
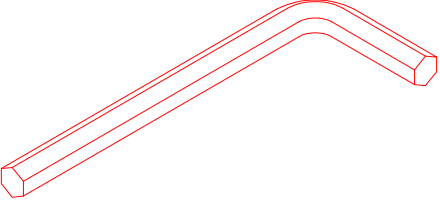
<p>A 1pc</p>  <p>Top</p>	<p>B 3pcs</p>  <p>Leg</p>	
<p>1 6pcs</p>  <p>Bolt $\text{Ø}5/16'' \times 2-3/8''$</p>	<p>2 6pcs</p>  <p>Washer $\text{Ø}5/8'' \times 1/32''$</p>	<p>3 1pc</p>  <p>Allen Wrench $\text{Ø}5/32'' \times 2-3/8''$</p>

Care and Cleaning Instructions:
Before using, wipe with a clean, dry cloth.
Periodically apply furniture wax to renew the finish. Avoid rubbing or scratching the surface with rough or abrasive objects.

For replacement parts or questions, please call Customer Service at 1-800-633-5096.

OC341300TX

Alden Round Side Table

Assembly Instructions

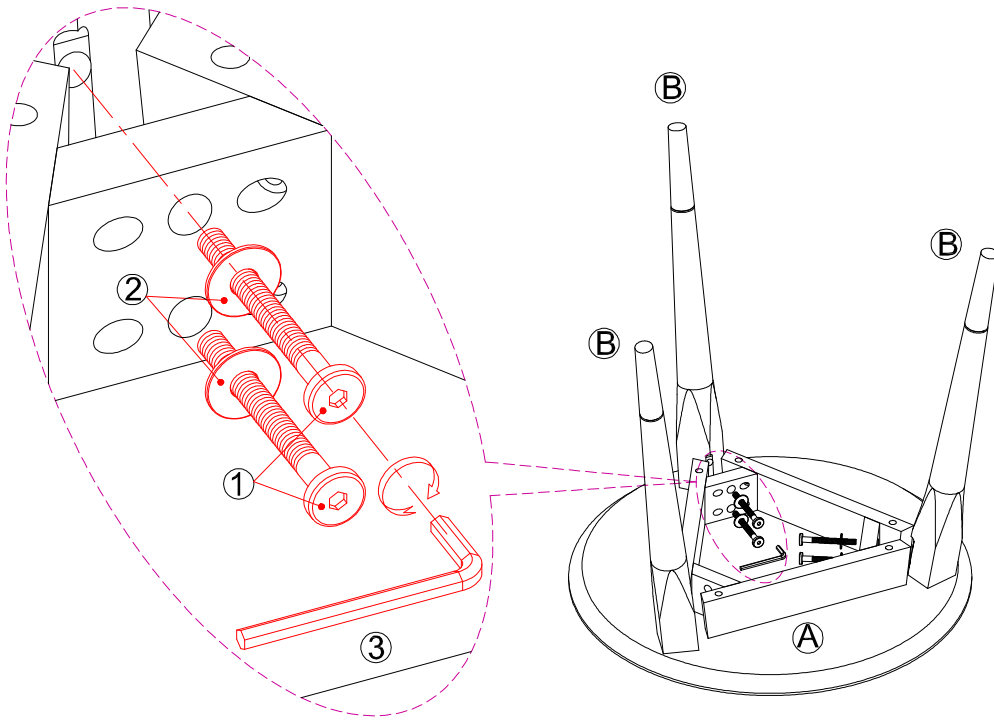

Step 1:

Attach Legs (B) to Top (A) using Bolts (1) and Washers (2).

Tighten Bolts using Allen Wrench (3) as shown.

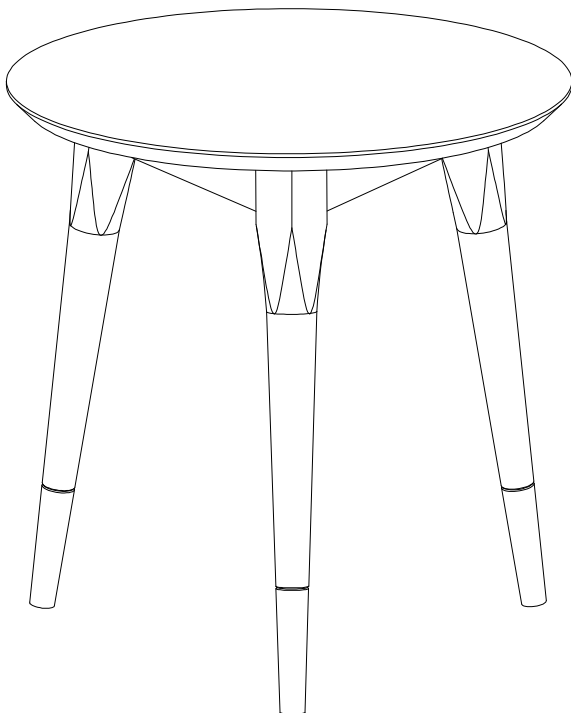

Step 2:

Assembly is complete.

Parts Replacement Form

Customer Information

Name _____

Address City/State/Zip _____

Code Phone Number _____

Please indicate where you purchased this item: Store/Website/Catalog _____

Please indicate color/size/style number:

Style No	Parts Letter	Parts Description	Quantity Needed
_____	_____	_____	_____
_____	_____	_____	_____
_____	_____	_____	_____

Please immediately examine this product carefully. Any request for missing parts or damage replacement must be received within 90 days of your receipt of the product. Replacement, if available, will be honored within this time frame. Parts will not be available for items arriving fully assembled. We do not recommend modifying product(s) and we are not responsible for any damages due to product modification(s). If damages or missing parts are not reported within 90 days of your receipt, we are under no obligation to provide parts or replacement merchandise.

For product issues, please contact Southern Enterprises at 800-633-5096 (toll-free) / 972-869-0111 (Dallas) Mon-Fri 9am – 4pm CST, or email us at service@seidal.com. Please ask for customer service representative for issues involving damages or replacement parts. Please ask for technical assistance representative for any issues with product and assembly/construction.

Please contact the retailer that you purchased from for returns.



Customer Service 1-800-633-5096
service@seidal.com
Southern Enterprises, Inc.
600 Freeport Parkway, Suite 200
Coppell, Texas 75019