

INSTALLATION

Product Manual

Version: 260068EU-00-25A-DC

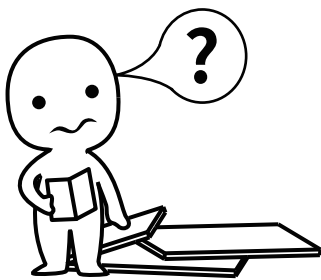

IMPORTANT INFORMATION!

please read the entire manual before starting to assemble and/or using this product. follow the manual thoroughly and keep it for further reference.

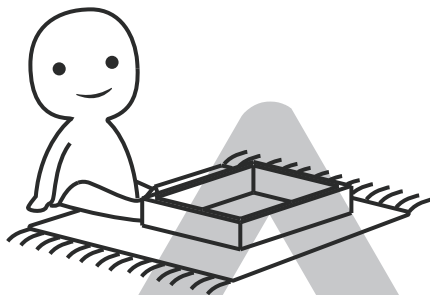
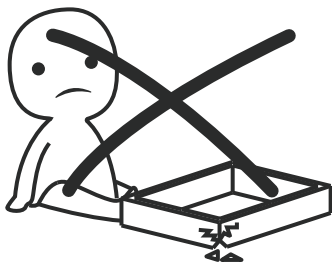

AVOID SCRATCHES!

In order to avoid scratching this furniture should be assembled on a soft layer- could be a rug.

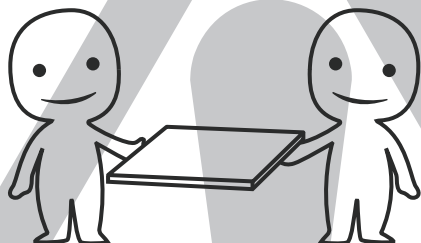

IMPROVE EFFICIENCY !

Try to find a partner to install with you, which can speed up the installation efficiency and shorten the time.

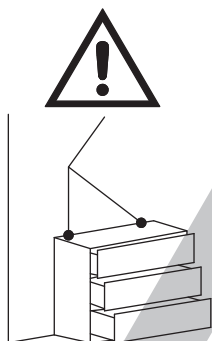

ANTI-TOPPLE WARNING !

Overturnd furniture can cause serious or fatal crush injuries. To prevent tipping over, be sure to use the wall attachment, if not included with this product. Please purchase the wall attachment that fit your wall. If unsure, seek professional advice. Please read and follow each step of the instructions carefully.

IMPORTANT !

It is important that any product which is assembled using any kind of screw is re-tightened 2 weeks after assembly, and once every 3 months - in order to assure stability through-out the lifespan of the product.

For regular maintenance and cleaning of the product, for the frame, please use a rag dipped in neutral detergent to fully wipe it, and then dry it with a clean rag. For glass materials, wipe with a rag dampened with water glass cleaner, and then dry with a dry rag.

Do not use an electric screwdriver, and do not use too much force when installing, because the board is easy to break.

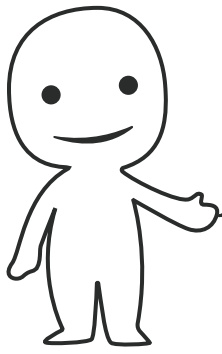

Please prepare the following tools

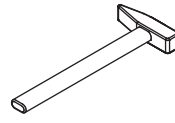
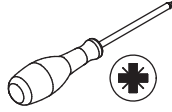
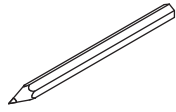

When installing, please carefully confirm whether each screw corresponds to the manual, accessories with similar shapes can be distinguished by size

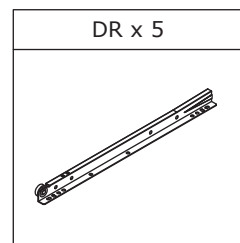
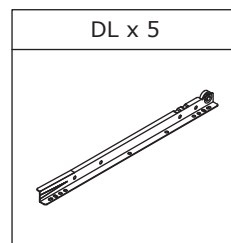
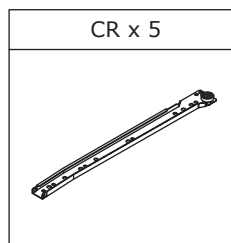
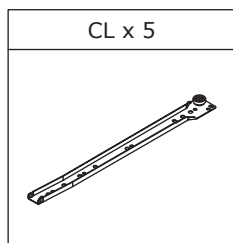
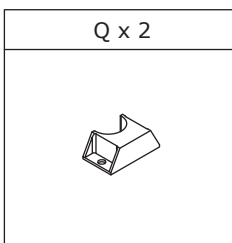
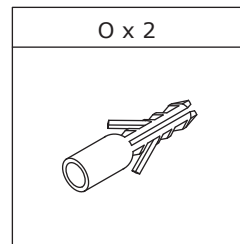
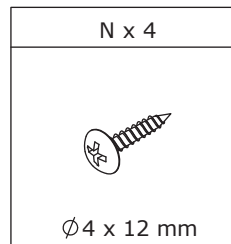
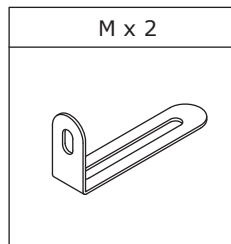
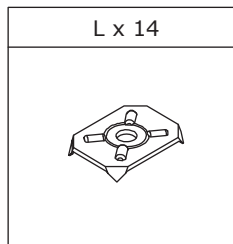
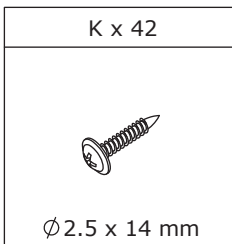
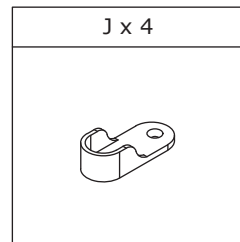
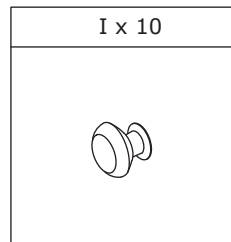
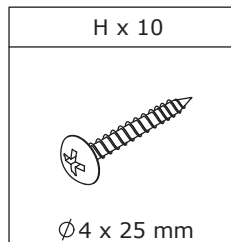
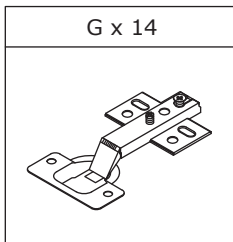
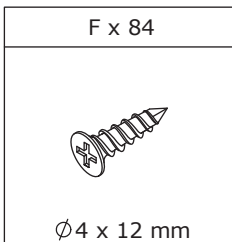
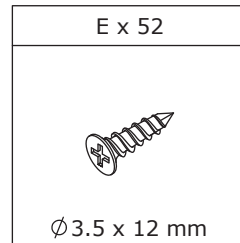
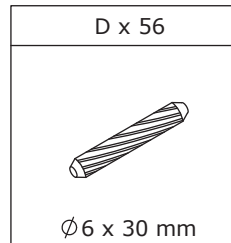
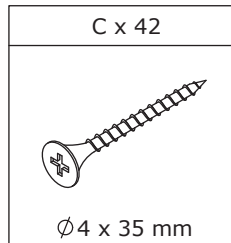
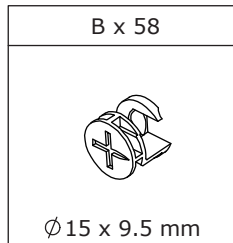
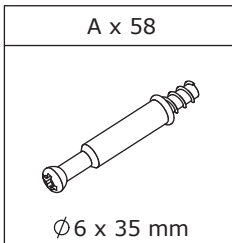

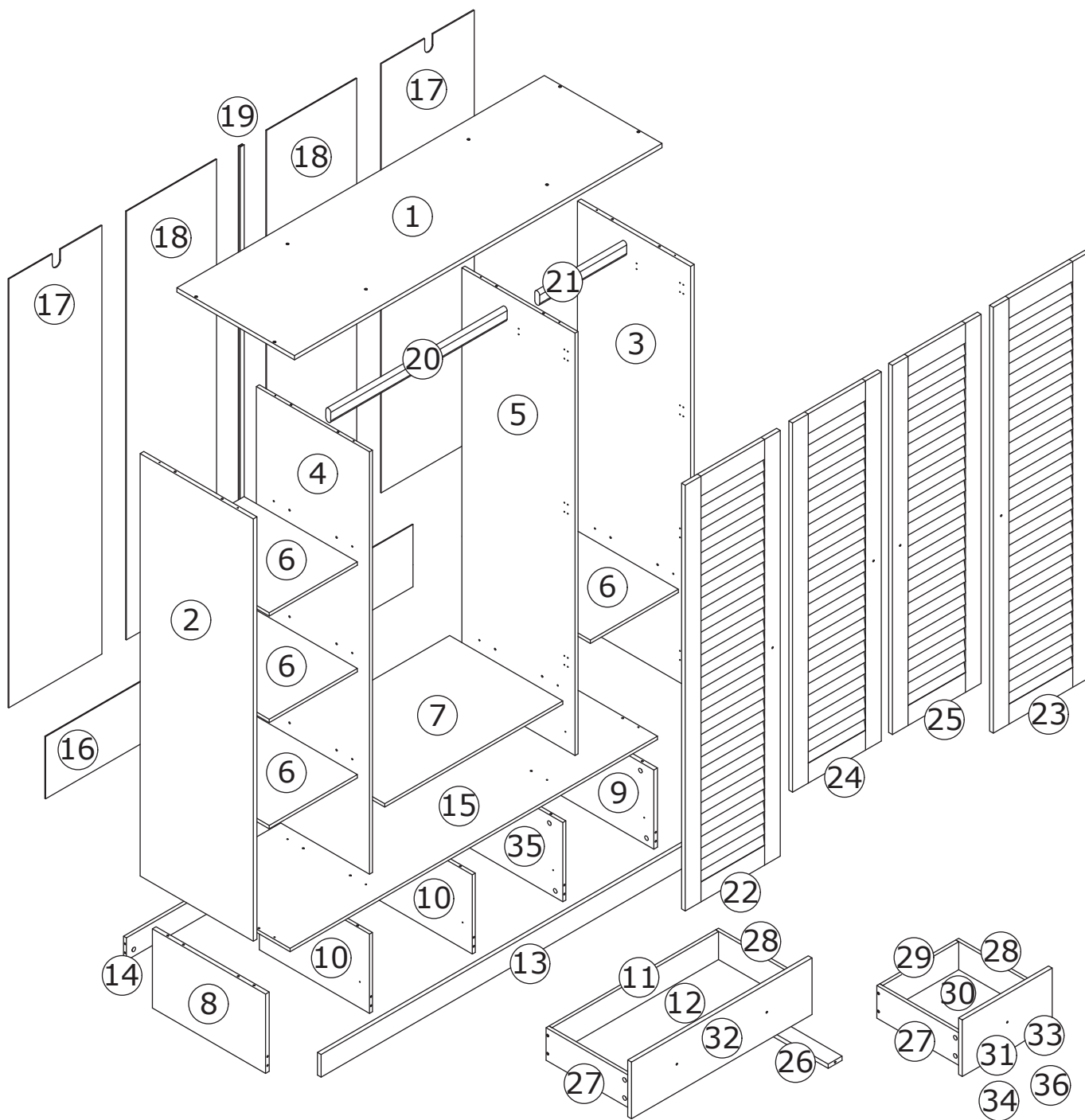

⚠ WARNING



Children have died from furniture tipover. To reduce the risk of furniture tipover:

- ALWAYS install Anti-tip device provided.
- NEVER put a TV on this product.
- NEVER allow children to stand, climb or hang on drawers, doors, or shelves.
- NEVER open more than one drawer at a time.
- Place heaviest items in the lowest drawers.

*This is a permanent label.
Do not remove!*

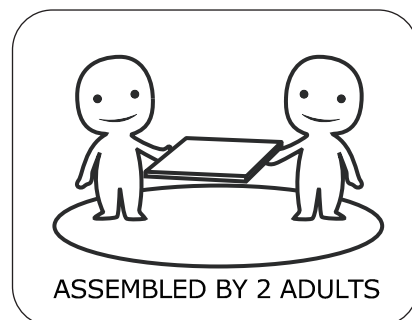

1

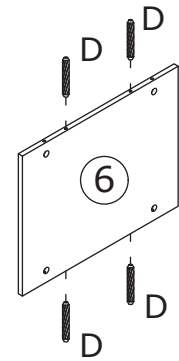
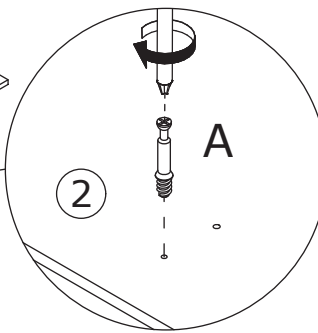
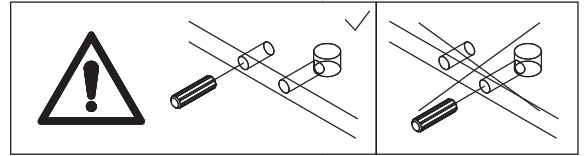
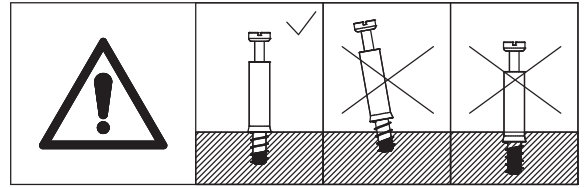
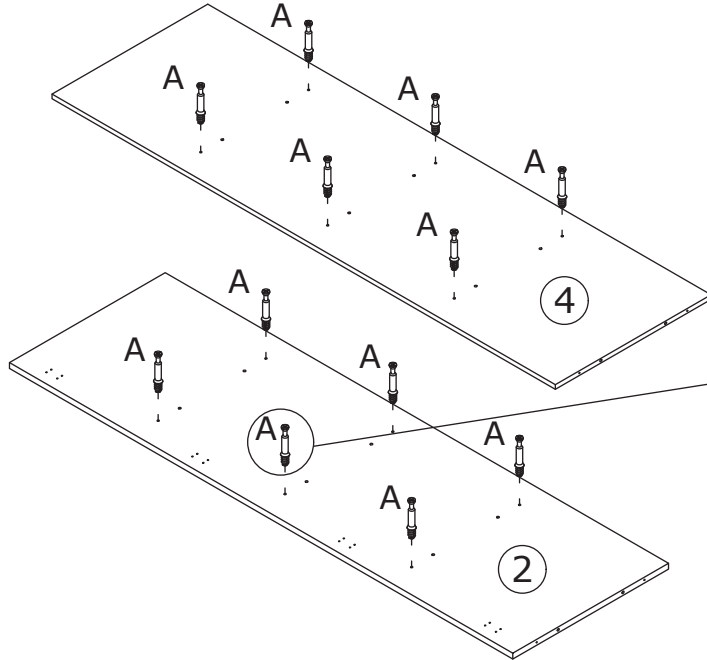
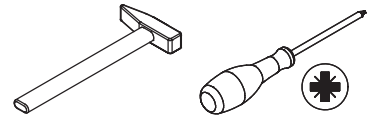
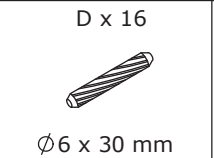
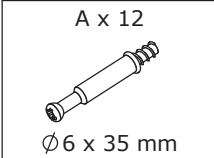

x4

2

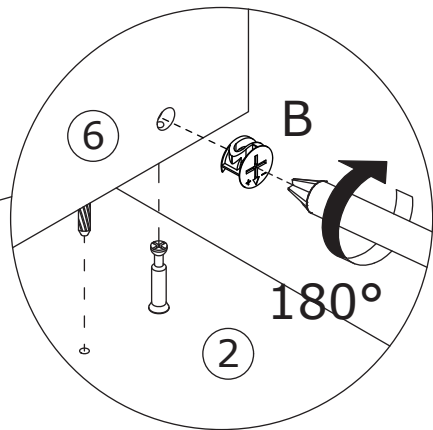
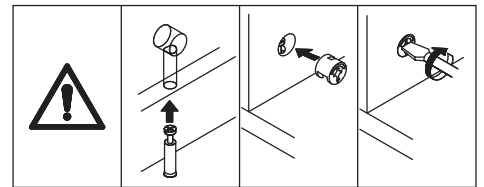
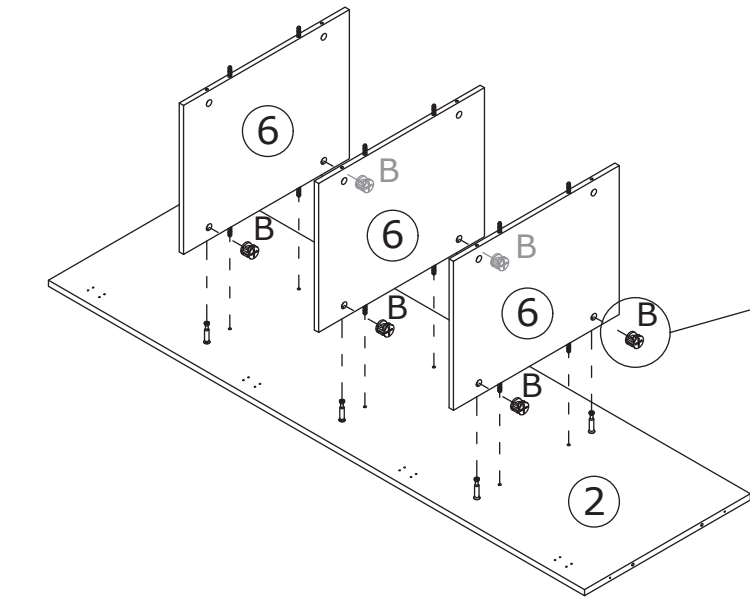
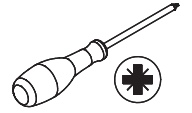
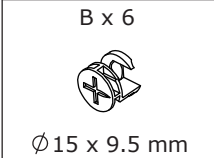

3

B x 6



Ø15 x 9.5 mm

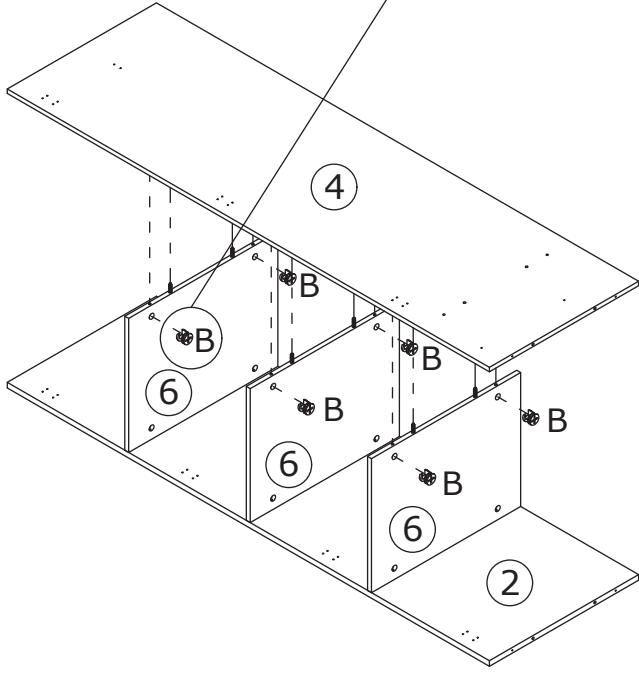
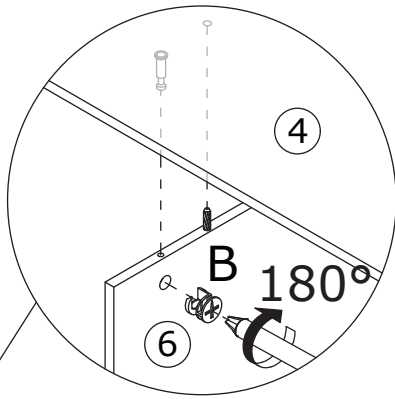
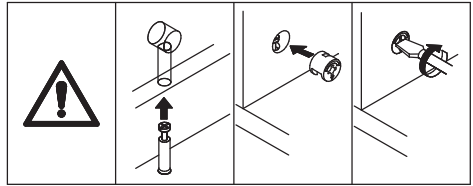
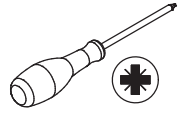

4

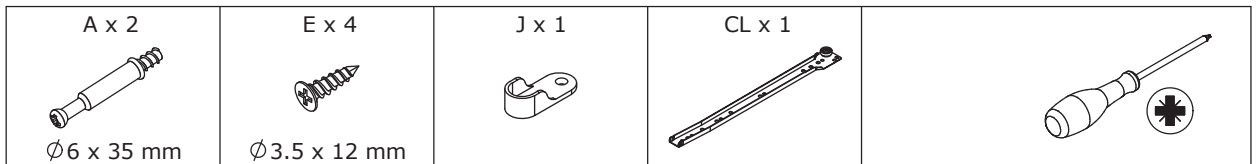

Fix rail(CL) to plate 4 using screw(E) as shown.

Screw eccentric rod(A) into plate 4 as shown.

Fix part(J) to plate 4 using screw(E) as shown.

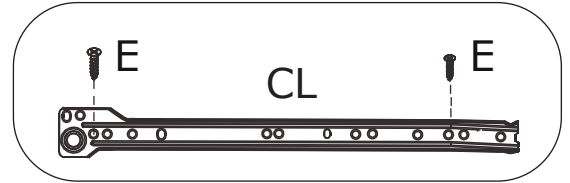
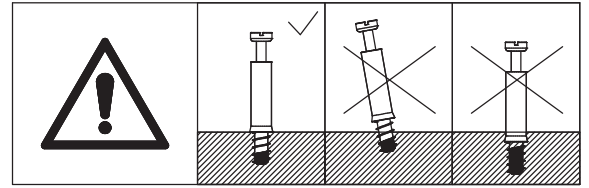

Schiene (CL) mit Schraube (E) an Platte 4 befestigen wie gezeigt.

Schrauben Sie die Exzenterstange (A) wie gezeigt in die Platte 4.

Teil (J) mit Schraube (E) an Platte 4 befestigen wie gezeigt.

Fixer le rail (CL) avec la vis (E) à la plaque 4 comme indiqué.

Visser la barre d'excentrique (A) dans la plaque 4 comme indiqué.

Fixer la pièce (J) avec la vis (E) sur la pla.

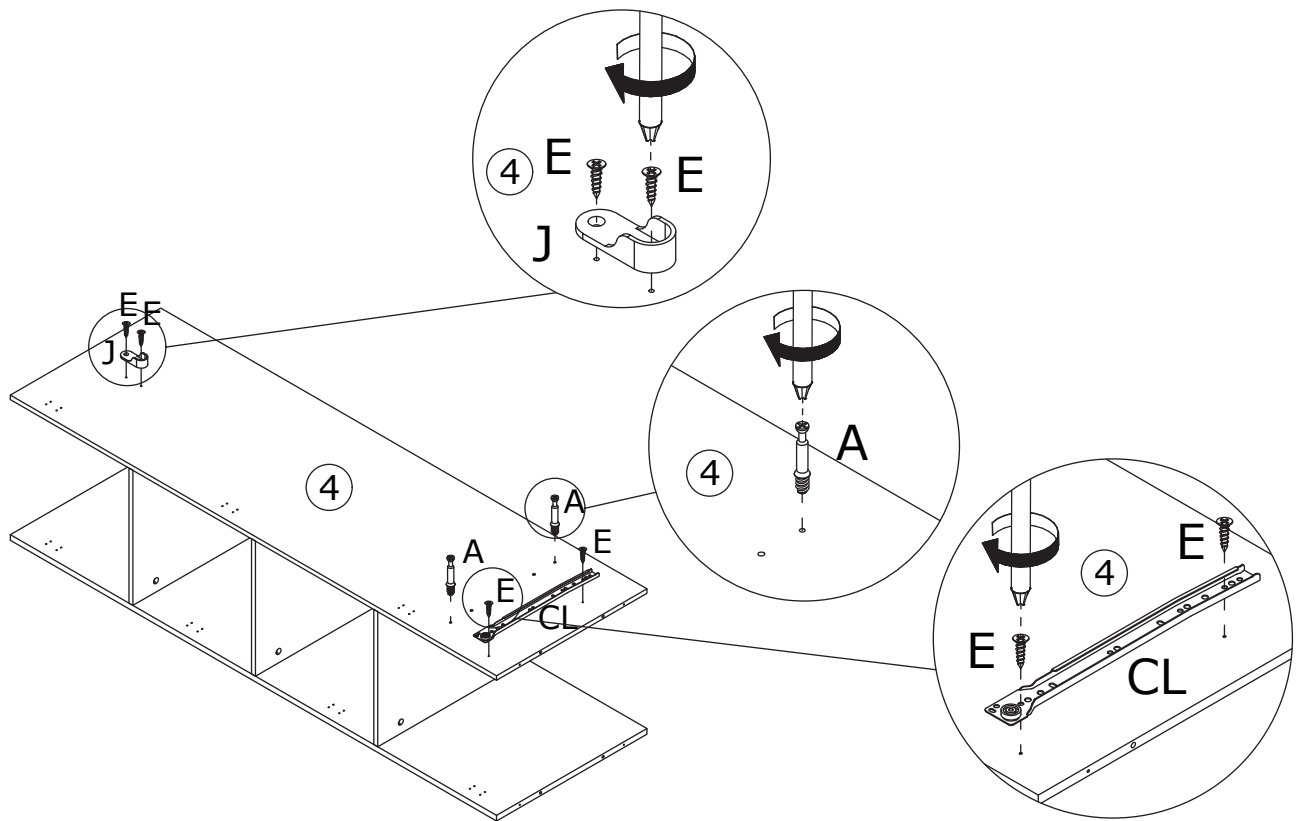

5

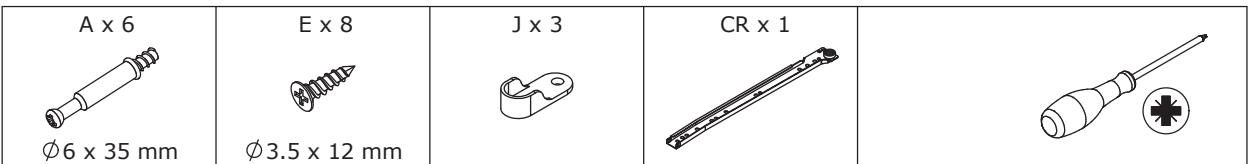

Screw eccentric rod(A) into plate 3, fix part(J) using screw(E) as shown. Screw eccentric rod(A) into plate 5, fix part(J) using screw(E) as shown. Then flip the plate, screw eccentric rod(A) and fix part(J) as well, fix slide rail(CR) using screw(E) as shown.

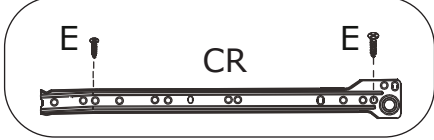
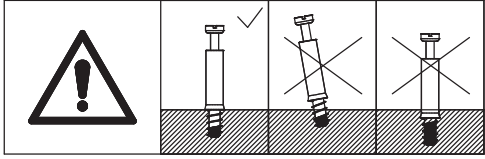

Schrauben Sie die Exzenterstange (A) in die Platte 3 und befestigen Sie das Teil (J) mit der Schraube (E) wie gezeigt. Exzenterstange (A) in Platte 5 schrauben, Teil (J) mit Schraube (E) wie abgebildet befestigen. Dann drehen Sie die Platte um, schrauben die Exzenterstange (A) an und befestigen auch das Teil (J), befestigen die Gleitschiene (CR) mit der Schraube (E) wie gezeigt.

Visser la tige excentrique (A) dans la plaque 3, fixer la pièce (J) à l'aide de la vis (E) comme indiqué. Visser la tige excentrique (A) dans la plaque 5, fixer la partie (J) à l'aide de la vis (E) comme indiqué. Retourner ensuite la plaque, visser la tige excentrique (A) et la partie fixe (J), fixer la glissière (CR) à l'aide de la vis (E) comme indiqué.

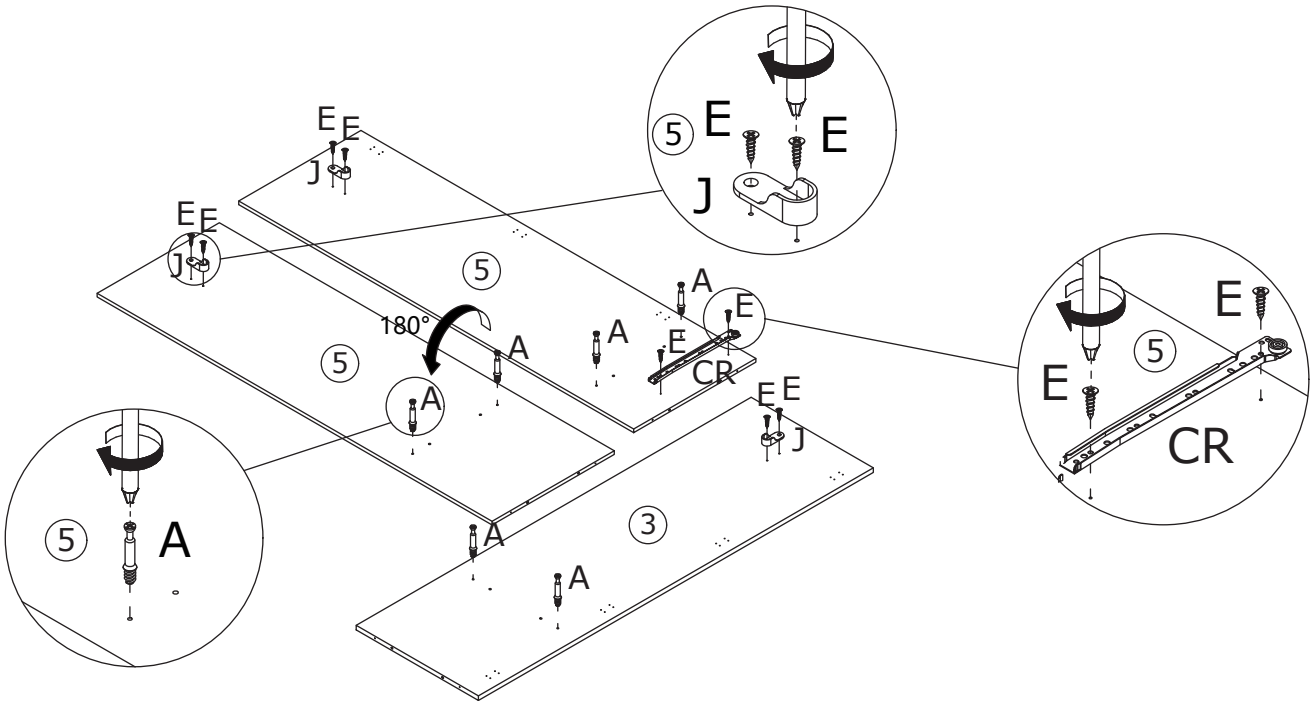

6

B x 4
Ø15 x 9.5 mm

D x 4
Ø6 x 30 mm

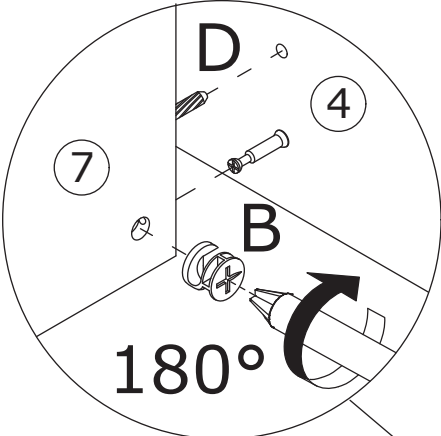
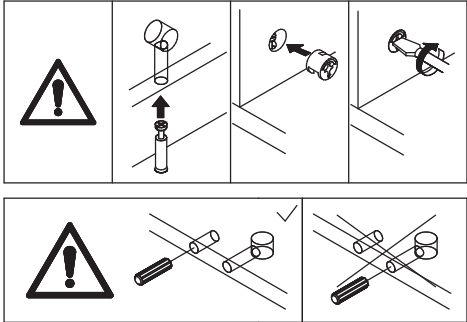
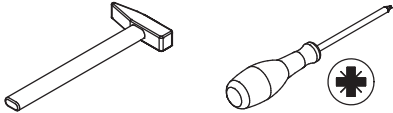

180°

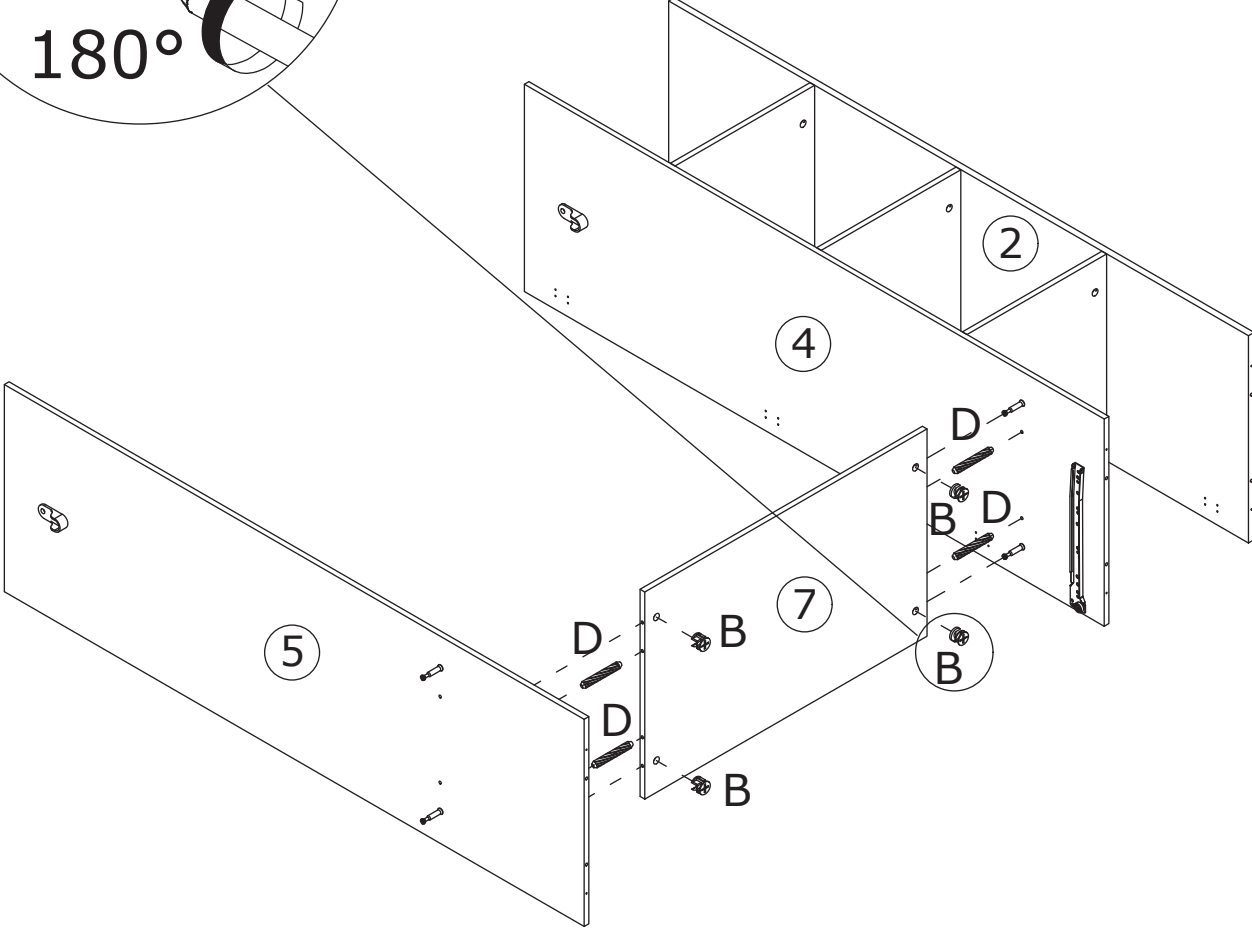

7

B x 4
Ø15 x 9.5 mm

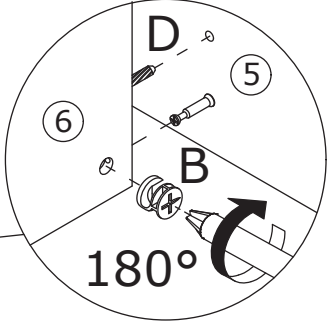
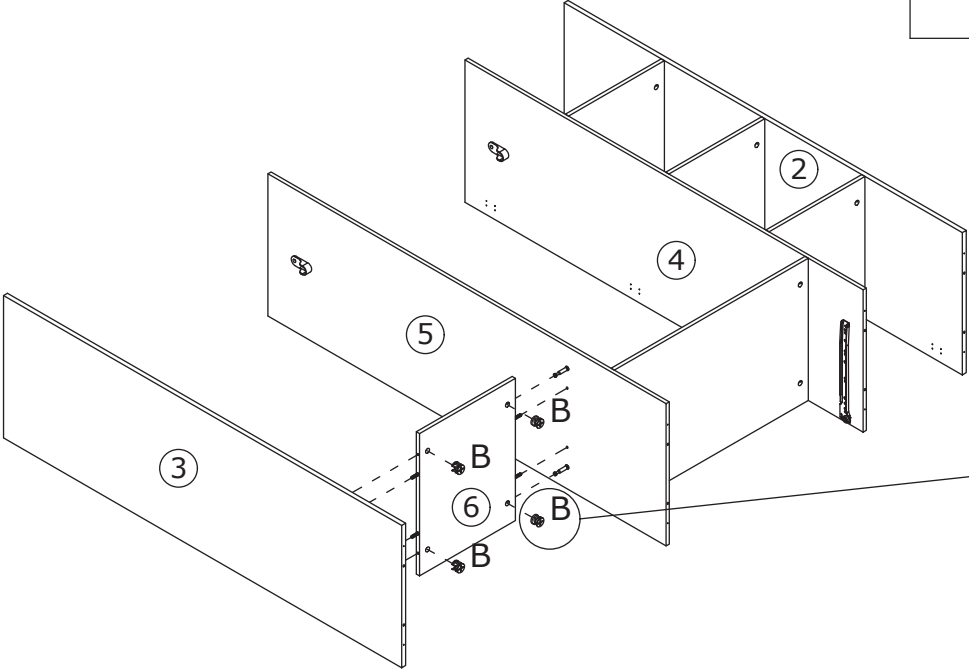
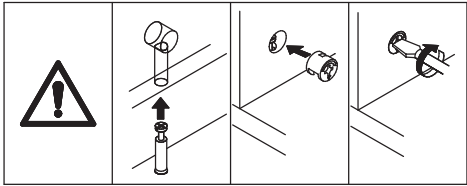
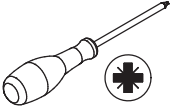



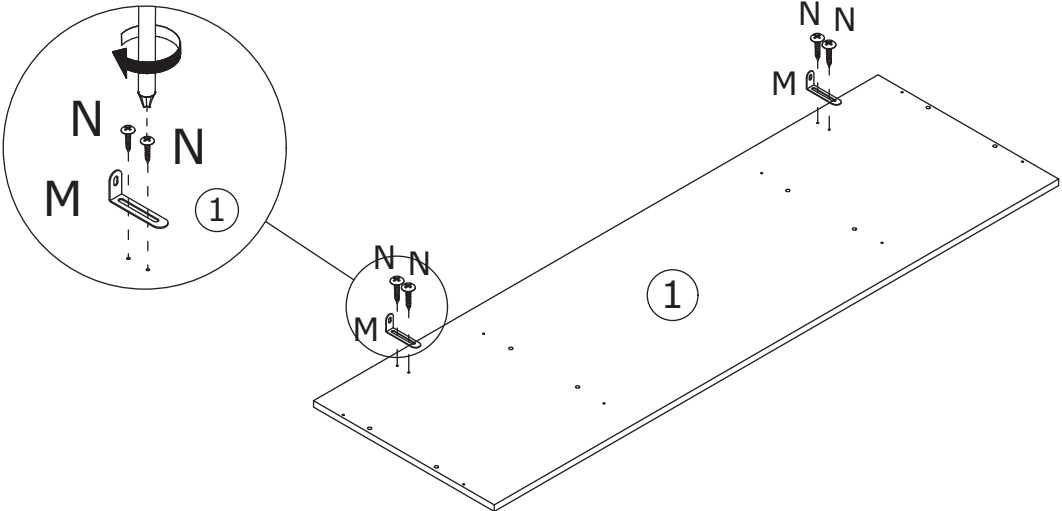
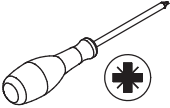

8

M x 2

N x 4
Ø4 x 12 mm

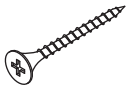

9

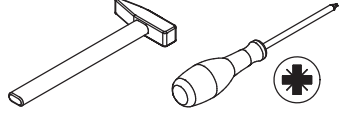
<p>C x 8</p>  <p>Ø4 x 35 mm</p>	<p>D x 8</p>  <p>Ø6 x 30 mm</p>	<p>E x 4</p>  <p>Ø3.5 x 12 mm</p>	<p>Q x 2</p> 	
--	--	--	---	---

Attach plate 1 to plate 3, 5, 4 and 2 with wooden dowel (D), then fix using screw (C) as shown. Fix part (Q) to plate 1 using screw (E) as shown.

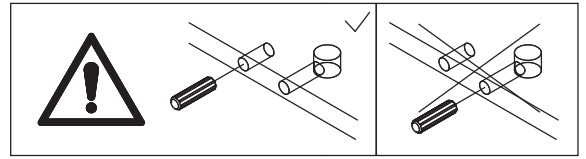

Fixer la plaque 1 aux plaques 3, 5, 4 et 2 à l'aide d'une cheville en bois (D), puis la fixer à l'aide de la vis (C) comme indiqué. Fixer la pièce (Q) sur la plaque 1 à l'aide de la vis (E) comme indiqué.

Befestigen Sie die Platte 1 an den Platten 3, 5, 4 und 2 mit dem Holzdübel (D) und dann mit der Schraube (C) wie gezeigt. Befestigen Sie Teil (Q) mit Schraube (E) an Platte 1 wie abgebildet.

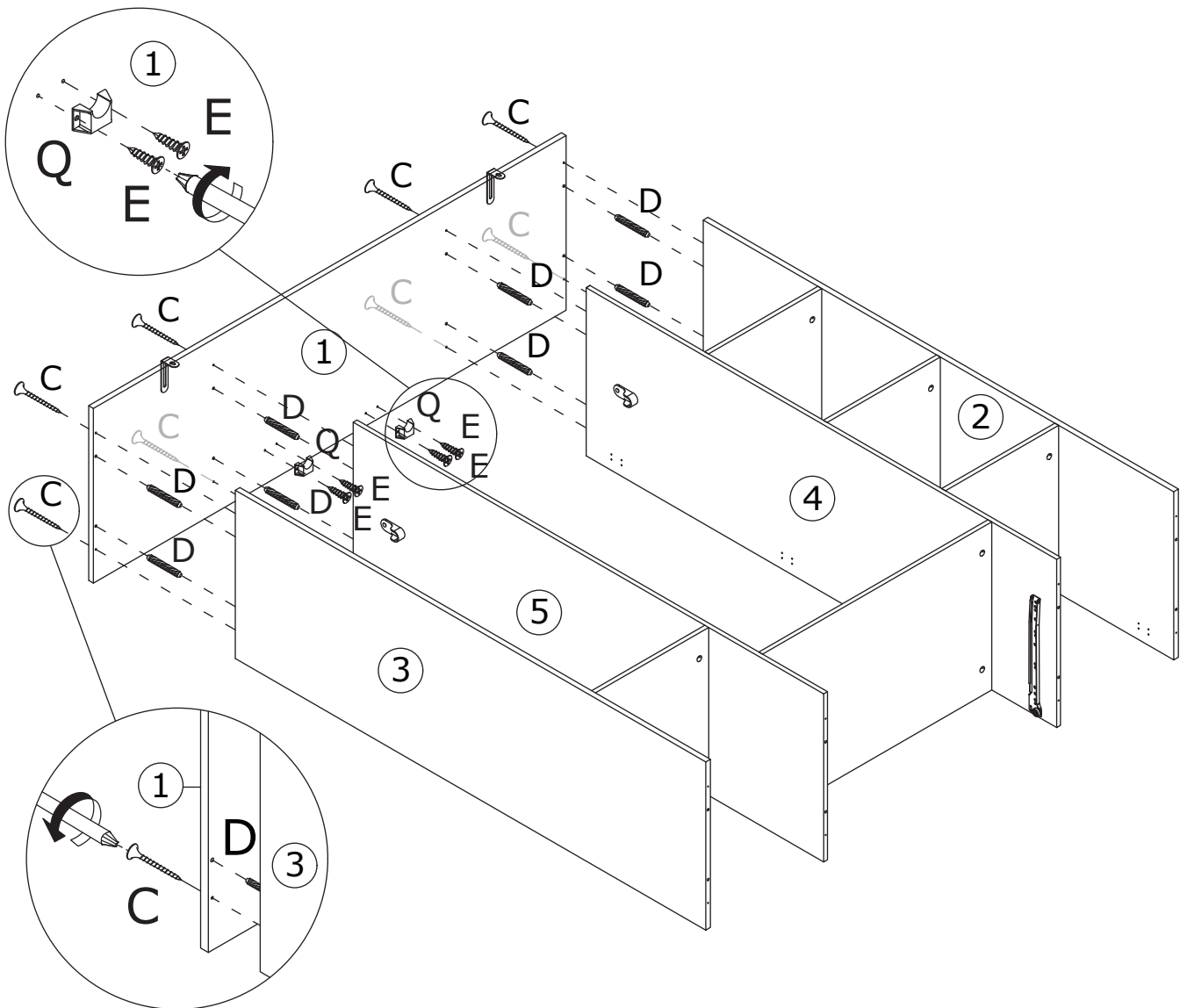

10

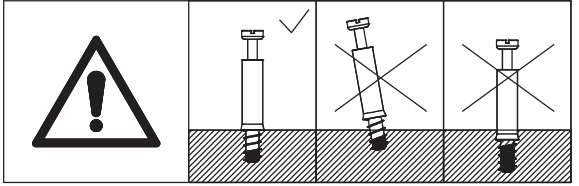
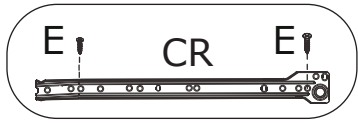
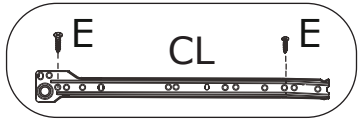
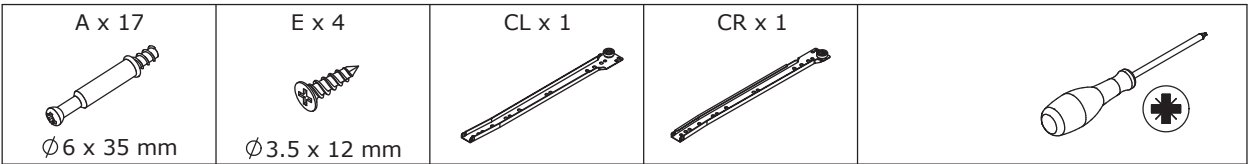

Screw eccentric rod(A) into plate 15, 13, 8 and 9 as shown.
Fix rail(CL) and (CR) to plate 8 and 9 using screw (E) as shown.

Schrauben Sie die Exzenterstange (A) wie gezeigt in die Platten 15,13, 8 und 9.
Befestigen Sie die Schienen (CL) und (CR) mit der Schraube (E) wie abgebildet an den Platten 8 und 9.

Visser la tige excentrique (A) dans les plaques 15, 13, 8 et 9 comme indiqué.
Fixer les rails (CL) et (CR) aux plaques 8 et 9 à l'aide de la vis (E) comme indiqué.

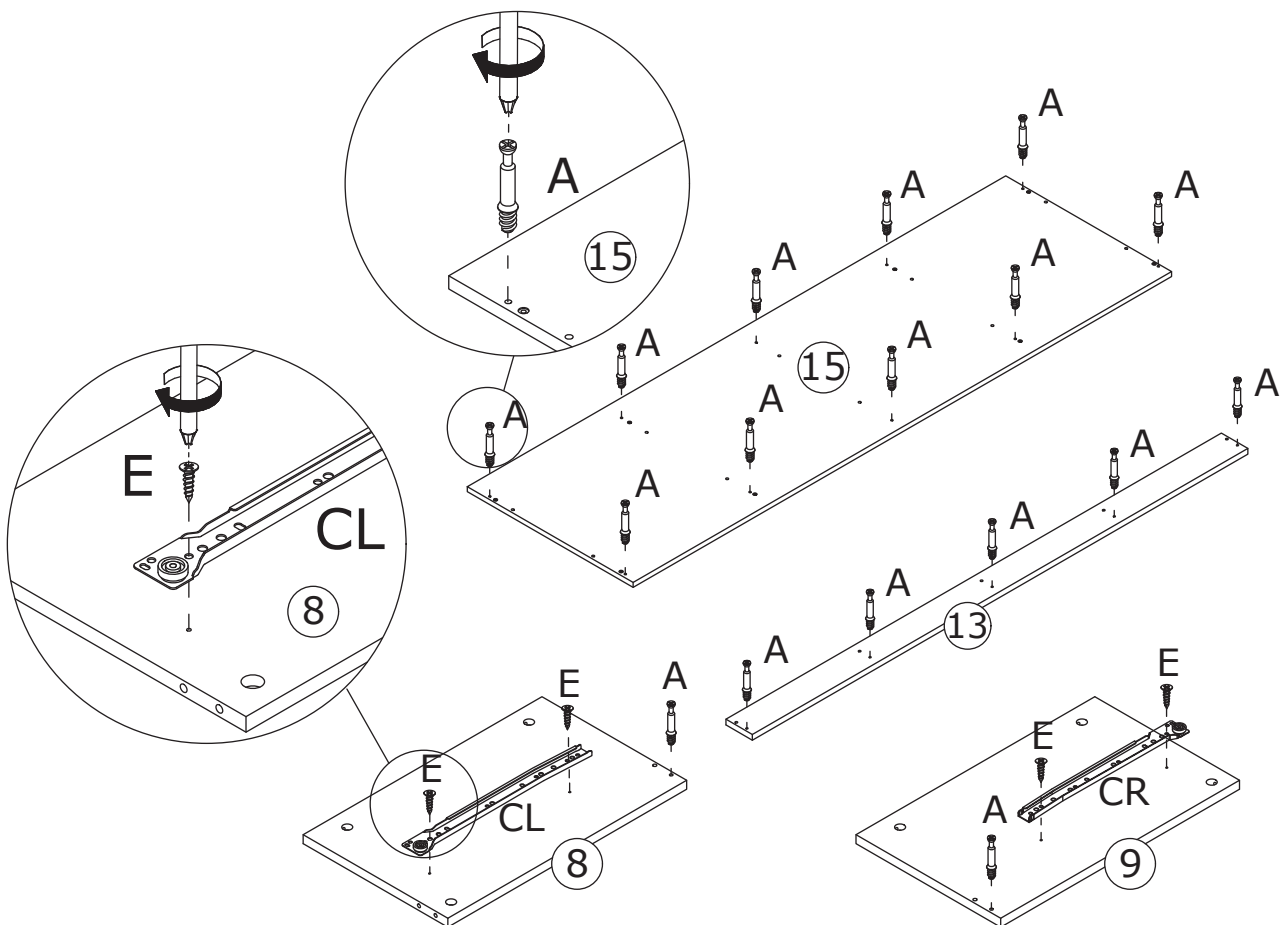

11

E x 12



Ø3.5 x 12 mm

CL x 3

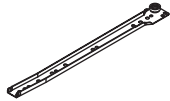

CR x 3

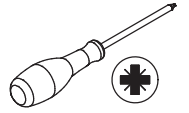
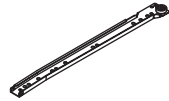

Fix slide rail(CL) to plate 10 and 35 respectively using screw(E) at first, then flip the two plates, fix slide rail(CR) as shown.

Befestigen Sie die Gleitschiene (CL) zunächst mit der Schraube (E) an der Platte 10 bzw. 35, drehen Sie dann die beiden Platten um und befestigen Sie die Gleitschiene (CR) wie bei E gezeigt.

Fixer la glissière (CL) aux plaques 10 et 35 respectivement à l'aide de la vis (E) dans un premier temps, puis inverser les deux plaques, fixer la glissière (CR) comme indiqué.

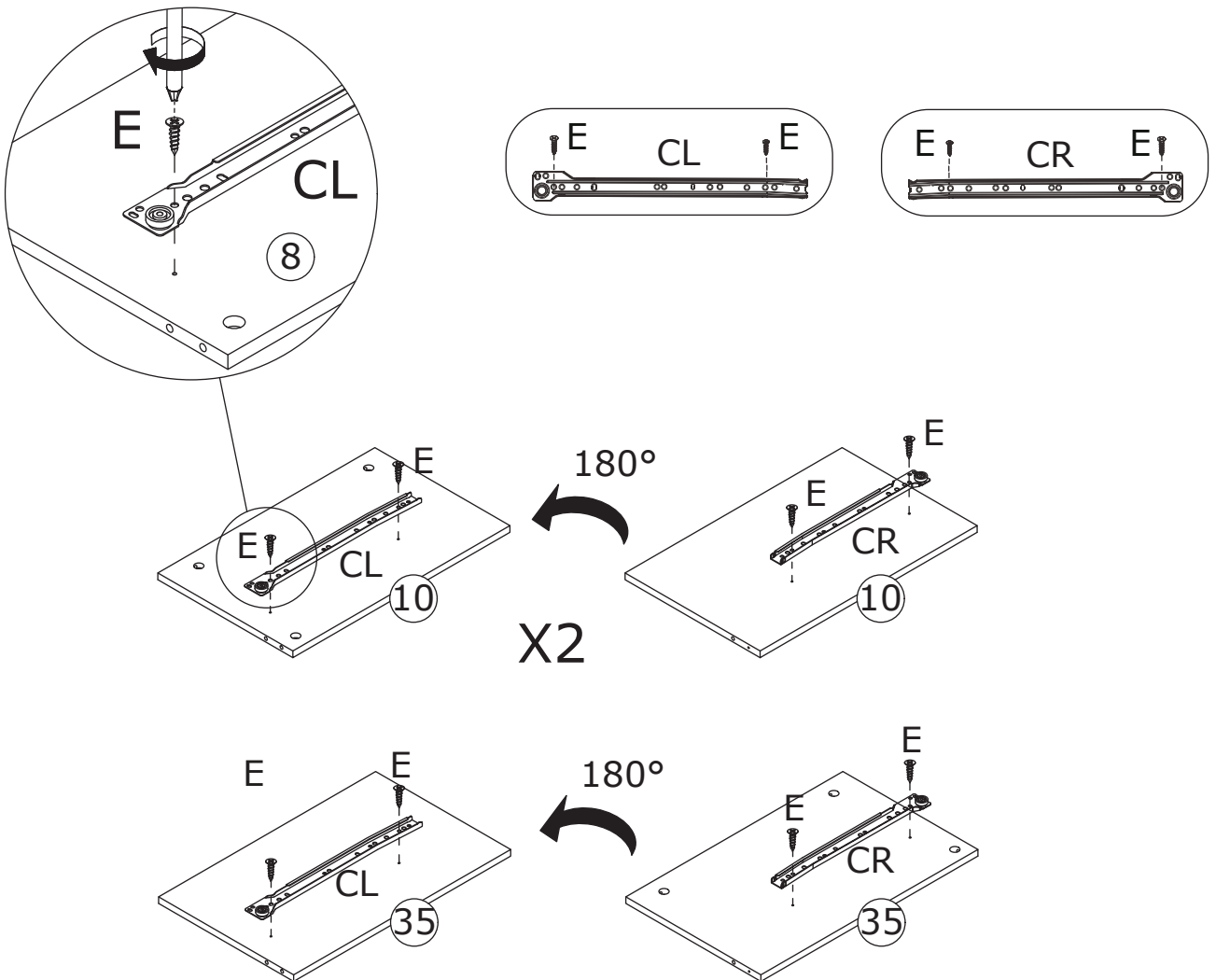

12

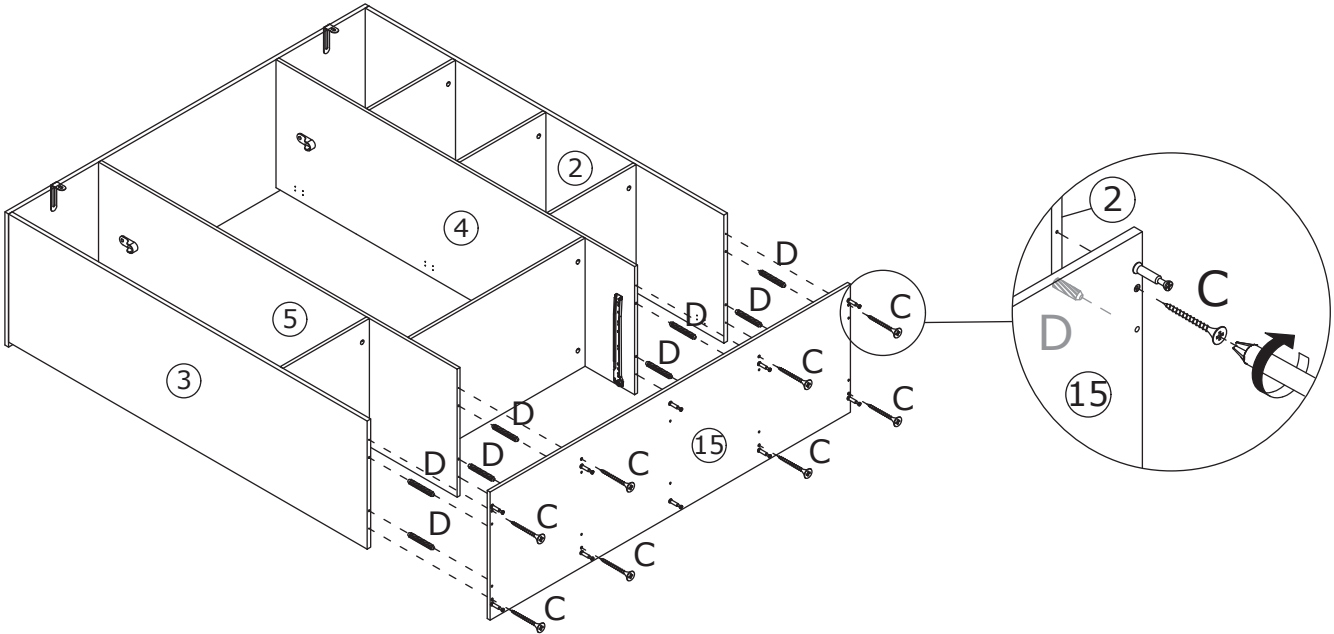
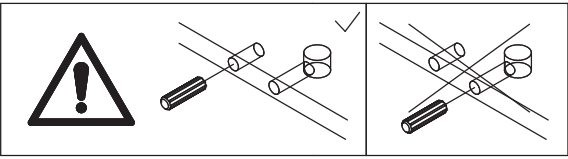
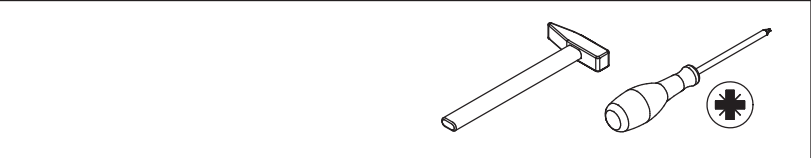
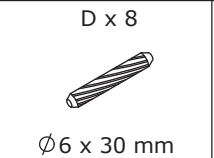
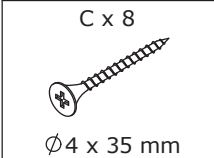

13

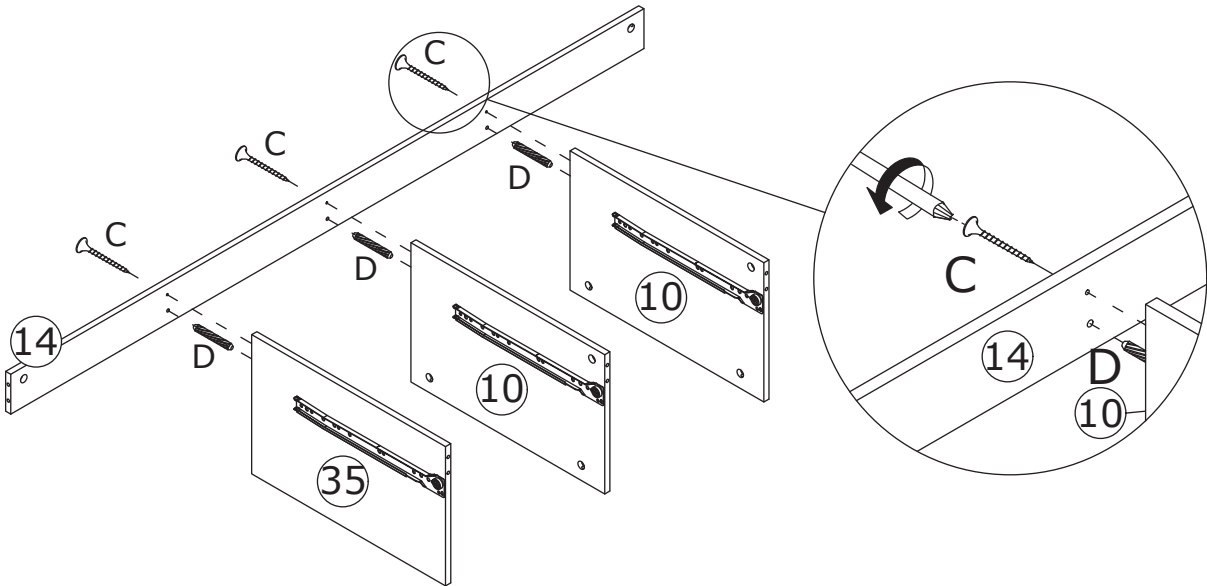
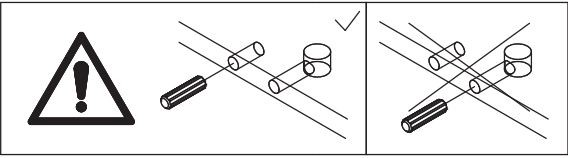
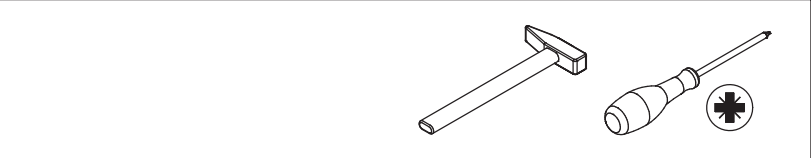
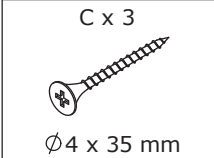

14

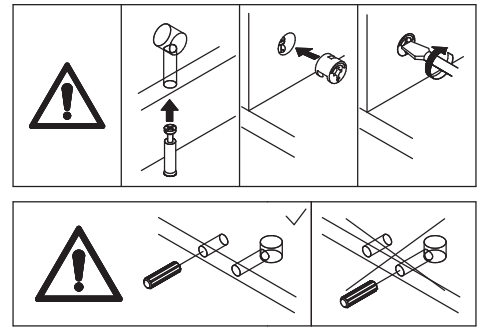
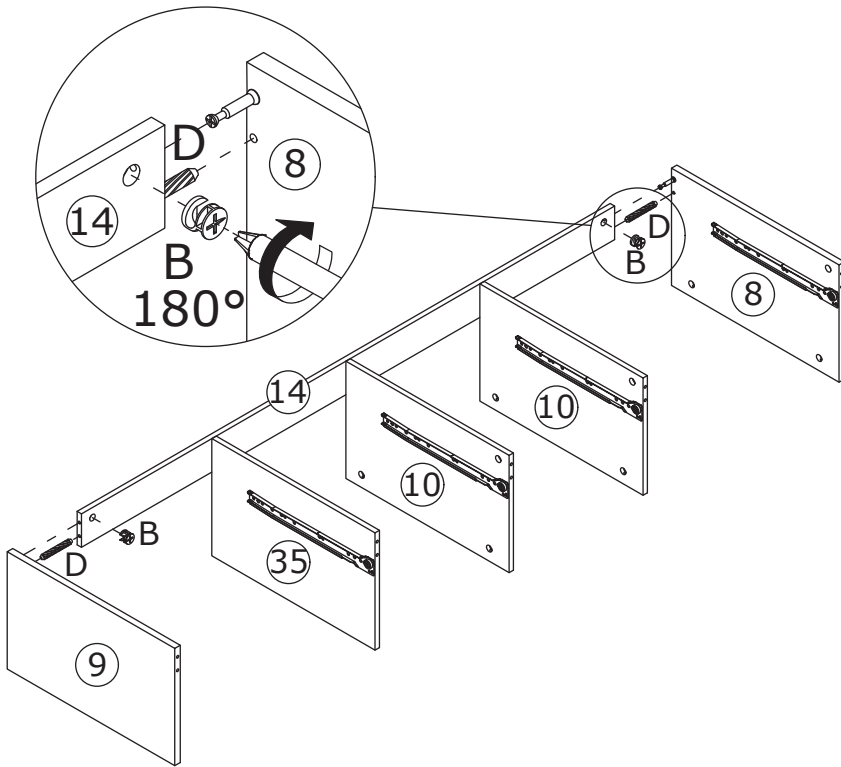
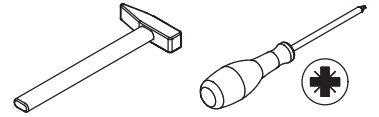
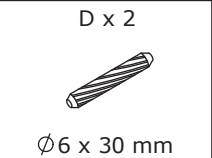
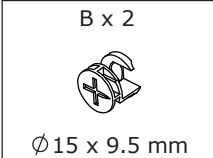

15

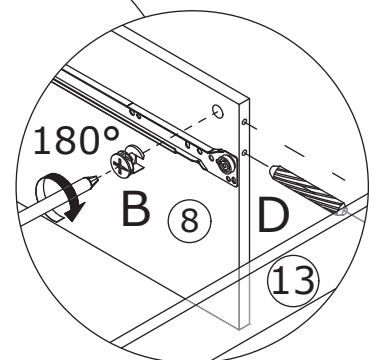
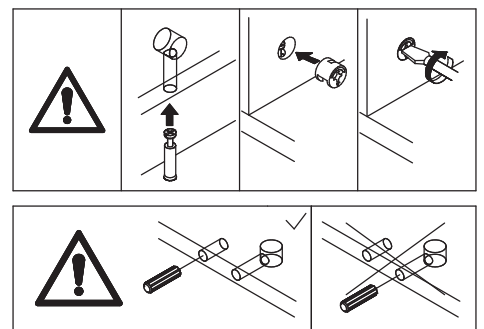
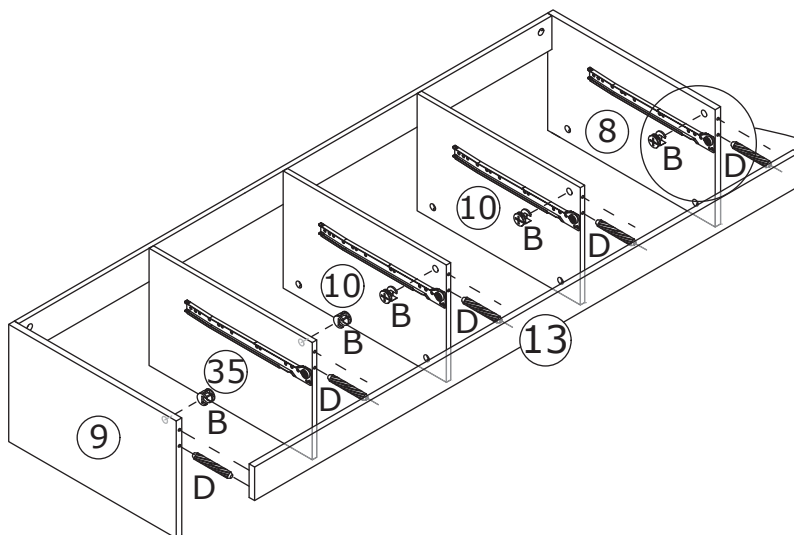
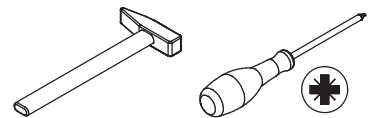
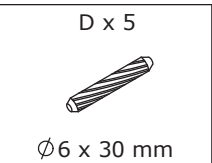
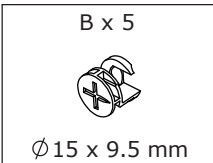

16



Attach the component to plate 15 with wooden dowel(D), put cam lock(B) into holes in plate 9, 35, 10, 8 and turn clockwise to tighten as shown.

Befestigen Sie das Bauteil mit dem Holzdübel (D) an der Platte 15, stecken Sie den Nockenverschluss (B) in die Löcher in der Platte 9, 35, 10, 8 und drehen Sie ihn im Uhrzeigersinn, um ihn wie abgebildet festzuziehen.

Fixer le composant à la plaque 15 à l'aide d'une cheville en bois (D), placer le verrou à came (B) dans les trous de la plaque 9, 35, 10, 8 et tourner dans le sens des aiguilles d'une montre pour serrer comme indiqué.

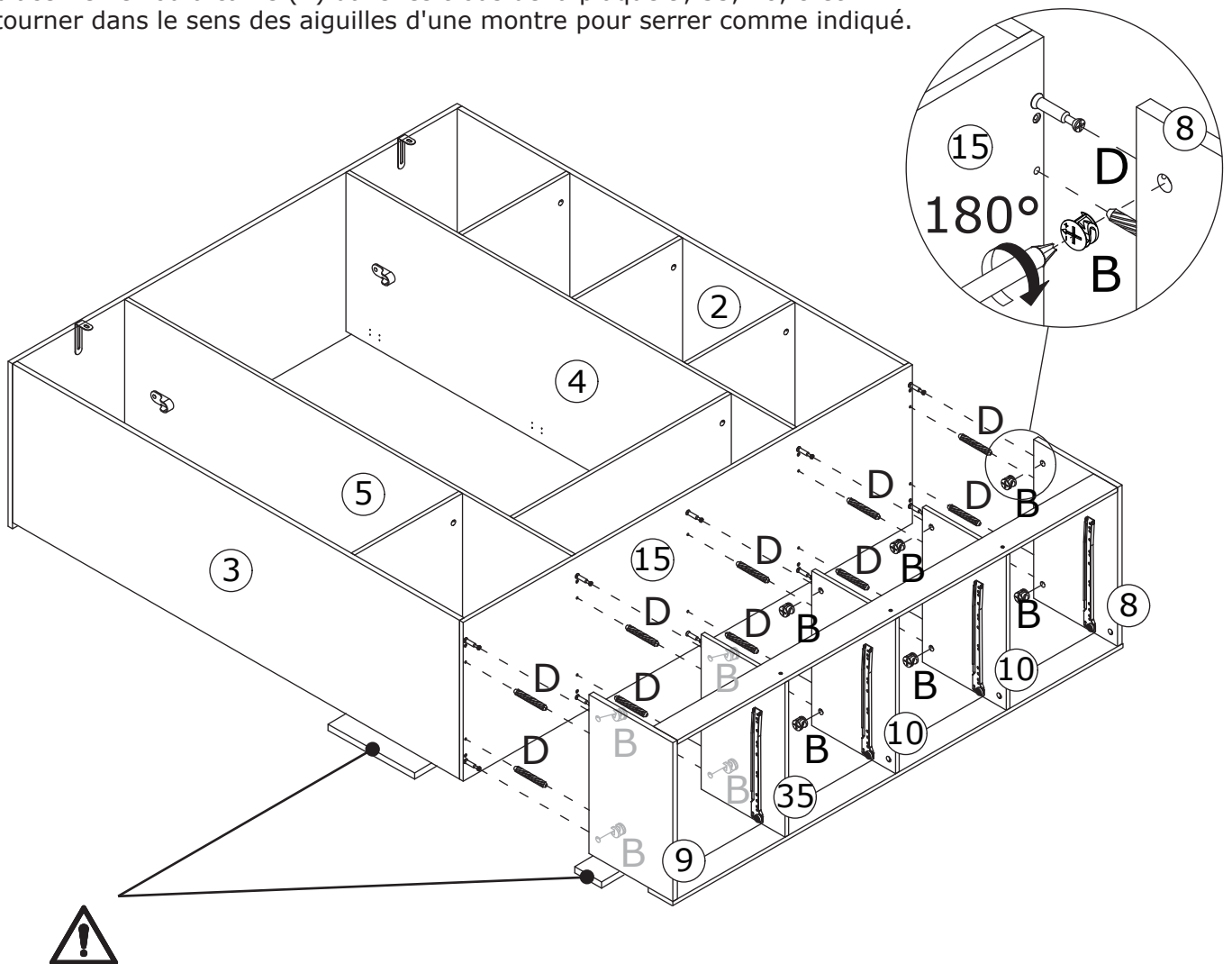
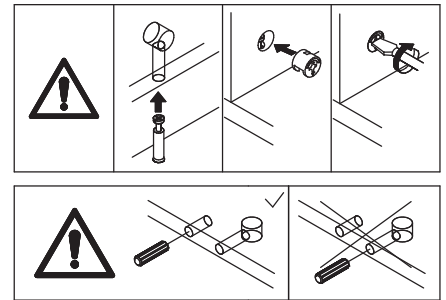

Please note that plate 3, 9 and plate 1, 13 are not at the same height. Place a 0.6-inch plate under plate 3, 9 to prevent it from falling and cracking the holes.

Bitte beachten Sie, dass Platte 3, 9 und Platte 1, 13 sich nicht auf der gleichen Höhe liegen. Legen Sie eine 0,6-Zoll-Platte unter die Platte 3, 9, um zu verhindern, dass sie herunterfällt und die Löcher beschädigt.

Veuillez noter que la plaque 3, 9 et la plaque 1, 13 ne sont pas au même hauteur. Placez une plaque de 0,6 pouce sous la plaque 3, 9 pour éviter qu'elle ne tombe et ne fissure les trous.

17



Fix back plate 16, 17, 18 and plank 19 using screw(K) at first.
Fix each plate 17, 18 and 16 together using part(L) with screw(K) as shown.

Befestigen Sie zunächst die Rückenplatte 16, 17, 18 und die Planke 19 mit der Schraube (K).
Befestigen Sie jede Platte 17, 18 und 16 zusammen mit Teil (L) und Schraube (K) wie gezeigt.

Fixer la plaque arrière 16, 17, 18 et la planche 19 à l'aide des vis (K) dans un premier temps.
Fixer chaque plaque 17, 18 et 16 ensemble en utilisant la pièce (L) avec la vis (K) comme indiqué.

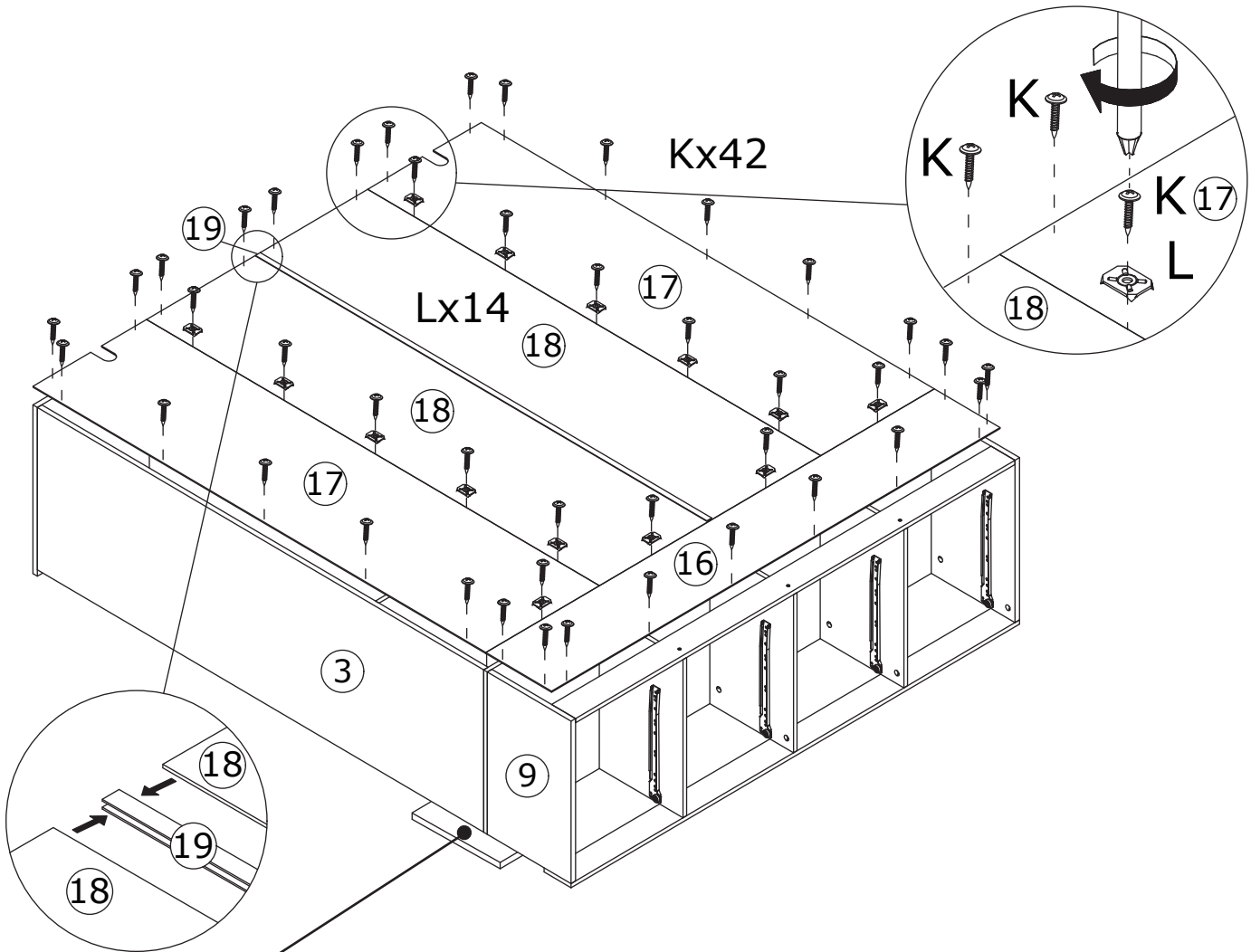

Please note that plate 3, 9 and plate 1, 13 are not at the same height.
Place a 0.6-inch plate under plate 3, 9 to prevent it from falling and cracking the holes.

Bitte beachten Sie, dass Platte 3, 9 und Platte 1, 13 sich nicht auf der gleichen Höhe liegen.
Legen Sie eine 0,6-Zoll-Platte unter die Platte 3, 9, um zu verhindern, dass sie herunterfällt und die Löcher beschädigt.

Veuillez noter que la plaque 3, 9 et la plaque 1, 13 ne sont pas au même hauteur.
Placez une plaque de 0,6 pouce sous la plaque 3, 9 pour éviter qu'elle ne tombe et ne fissure les trous.

18

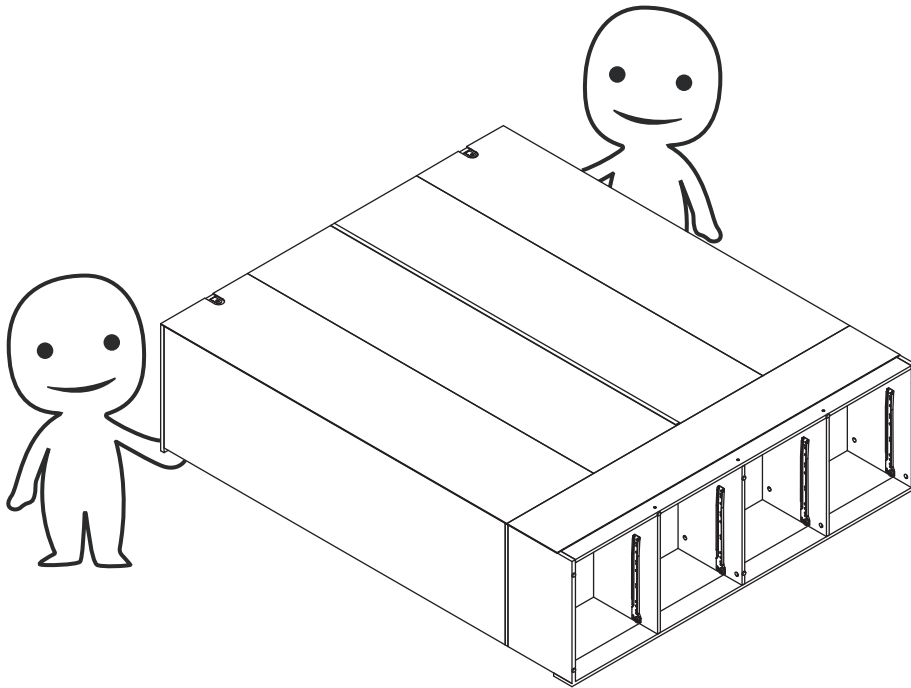

Two people are required to lift the cabinet at the same time, otherwise the uneven force will cause the hole to split.

Zum Anheben des Schrankes sind zwei Personen den Schrank gleichzeitig zu heben, Andernfalls wird das Loch durch die ungleichmäßige Kraft aufgerissen.

Deux personnes sont nécessaires pour soulever l'armoire en même temps, sinon l'inégalité de la force l'ouverture se fissurera.

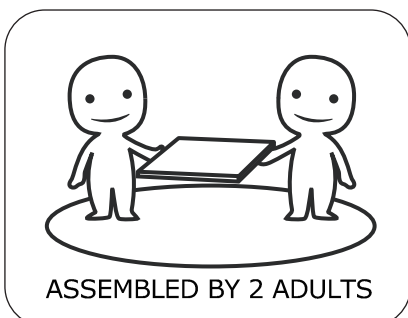
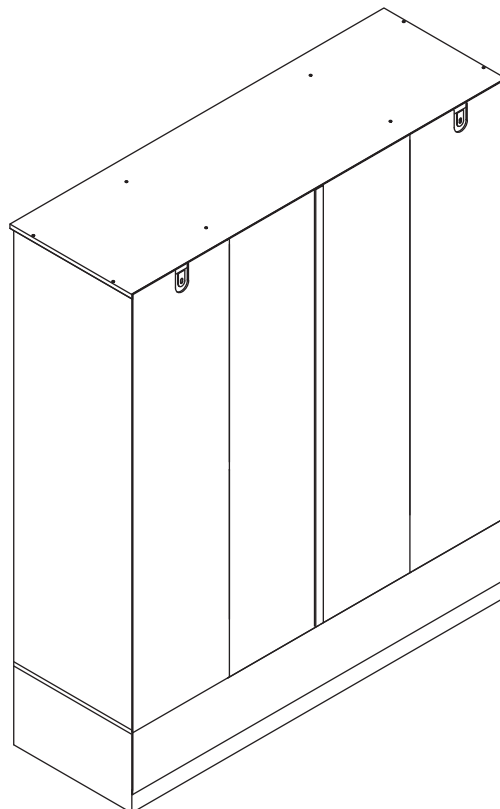

19

C x 21
Ø4 x 35 mm

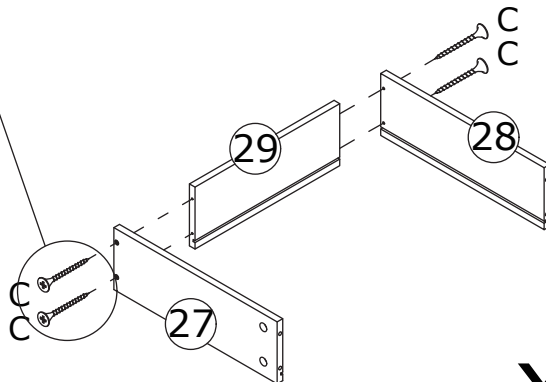
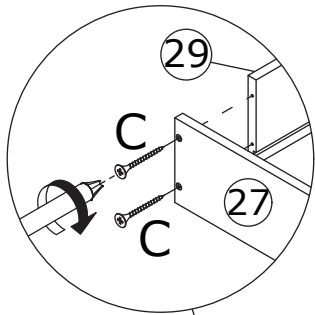
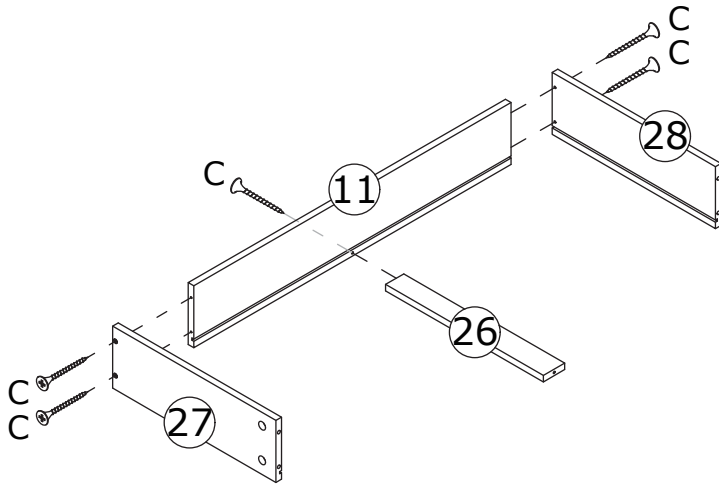
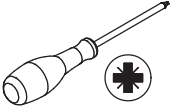

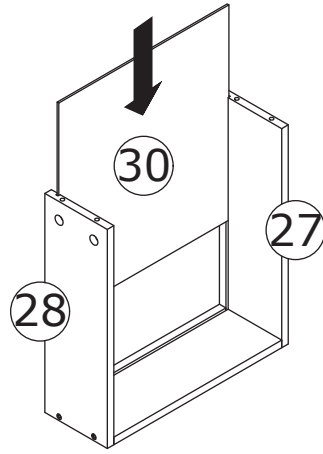
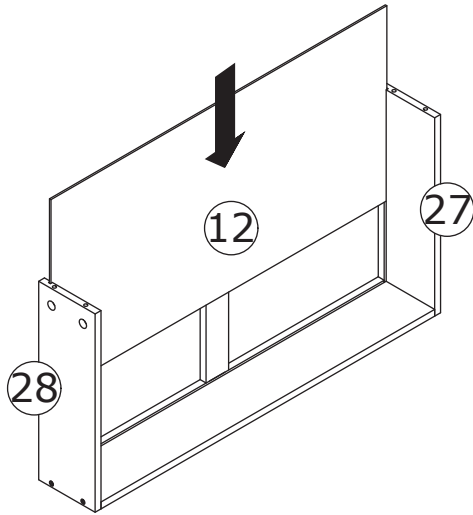

x4

20



x4

21

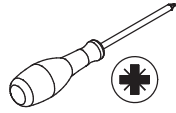
<p>A x 21</p>  <p>Ø 6 x 35 mm</p>	<p>H x 6</p>  <p>Ø 4 x 25 mm</p>	<p>I x 6</p> 	
--	---	--	---

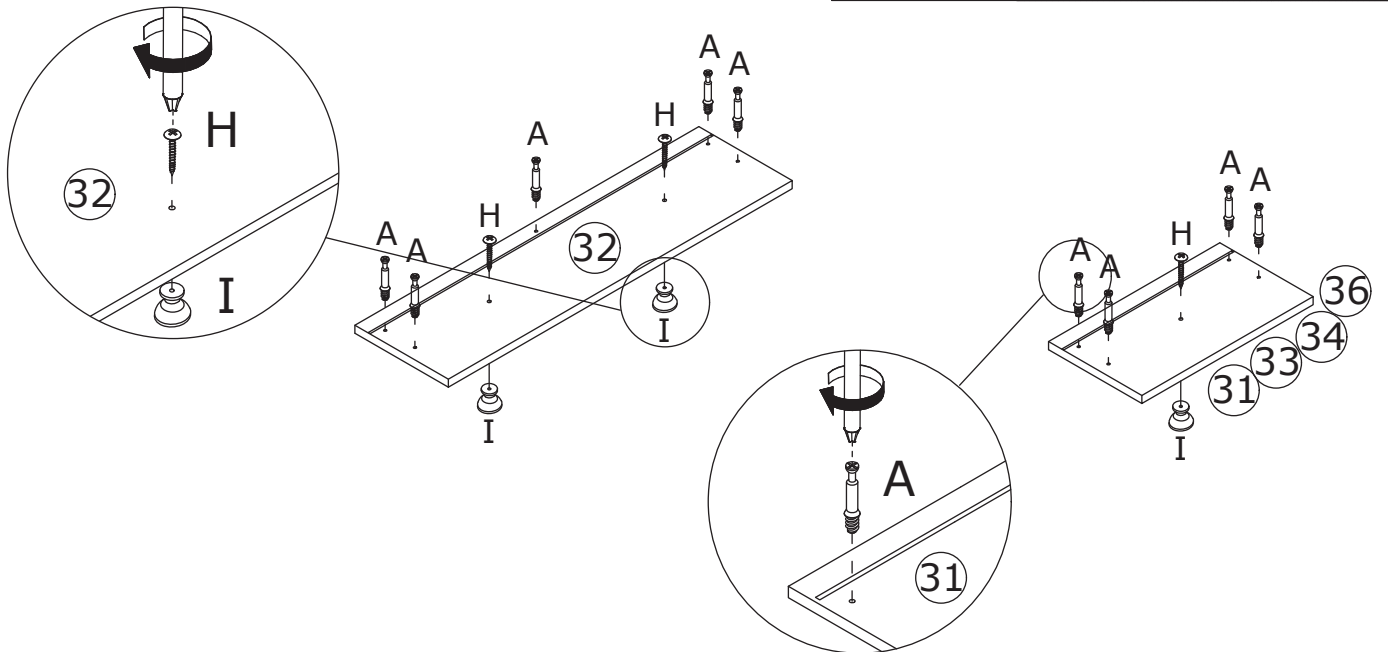
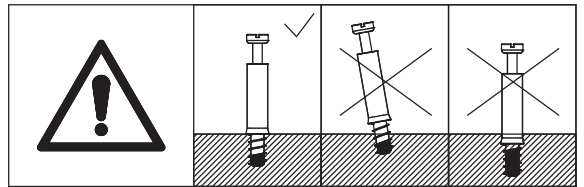

22

B x 21

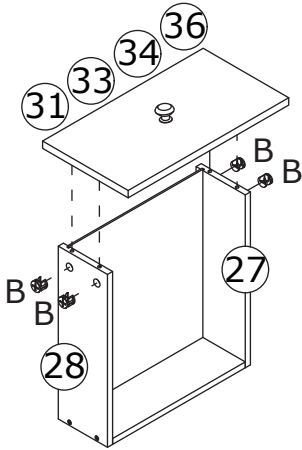
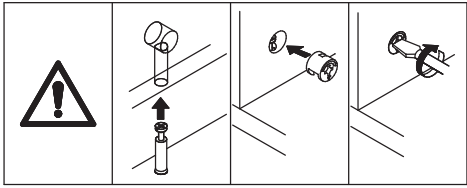
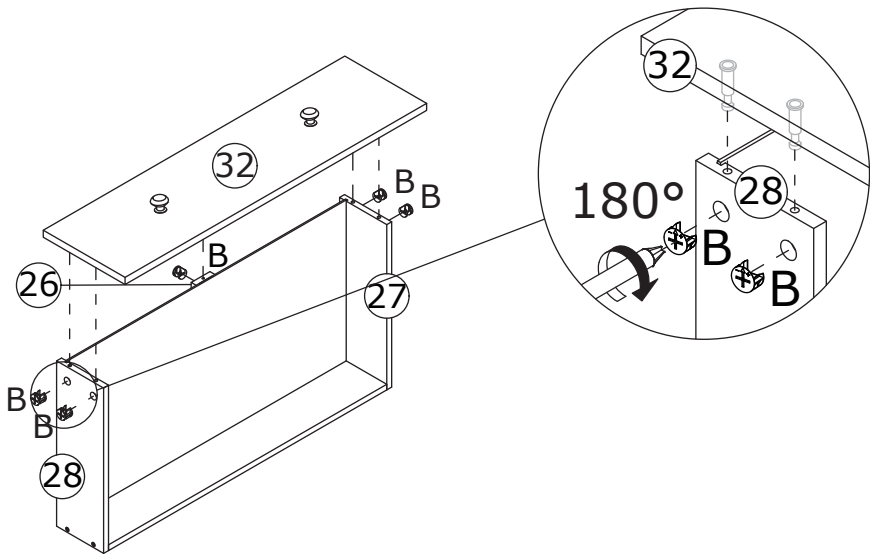
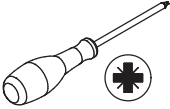
Ø 15 x 9.5 mm

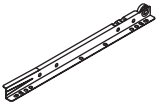

23

E x 20

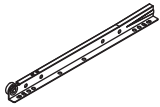
Ø 3.5 x 12 mm

DL x 5

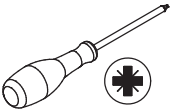
DR x 5



Fix runner(DL) and (DR) to plate 27 and 28 respectively using screw(E) as shown.

Befestigen Sie die Läufer (DL) und (DR) mit der Schraube (E) wie abgebildet an der Platte 27 bzw. 28.

Fixer les patins (DL) et (DR) aux plaques 27 et 28 respectivement à l'aide de la vis(E) comme indiqué.

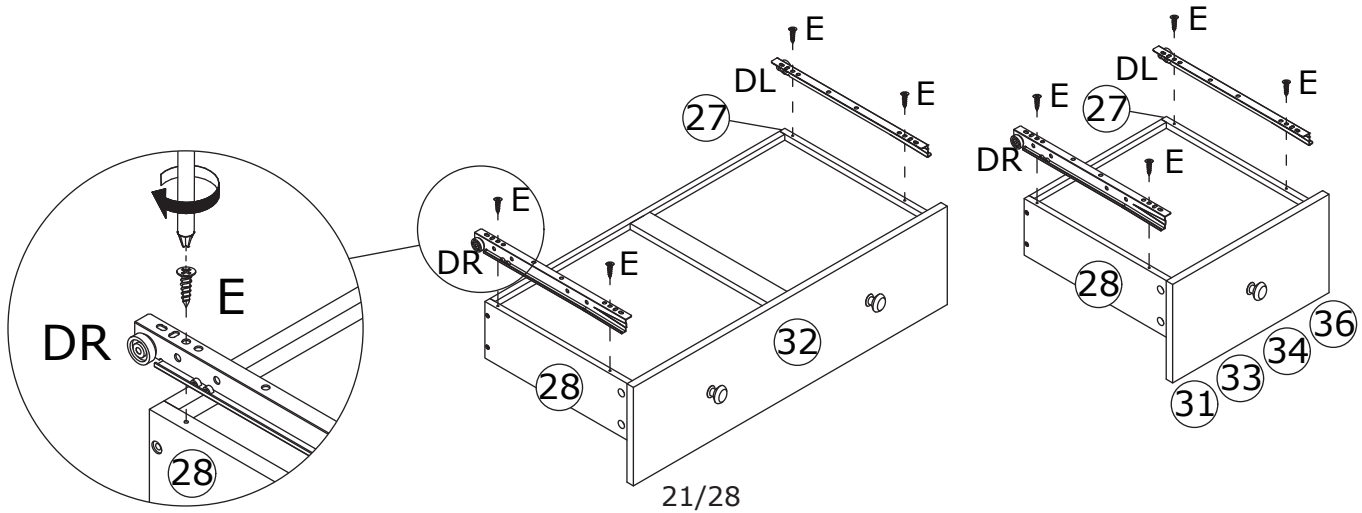

24



Align rails, slide the drawer.
Place clothing rod 20 and 21 in.

Schienen ausrichten, Schublade einschieben.
Kleiderstange 20 und 21 einlegen.

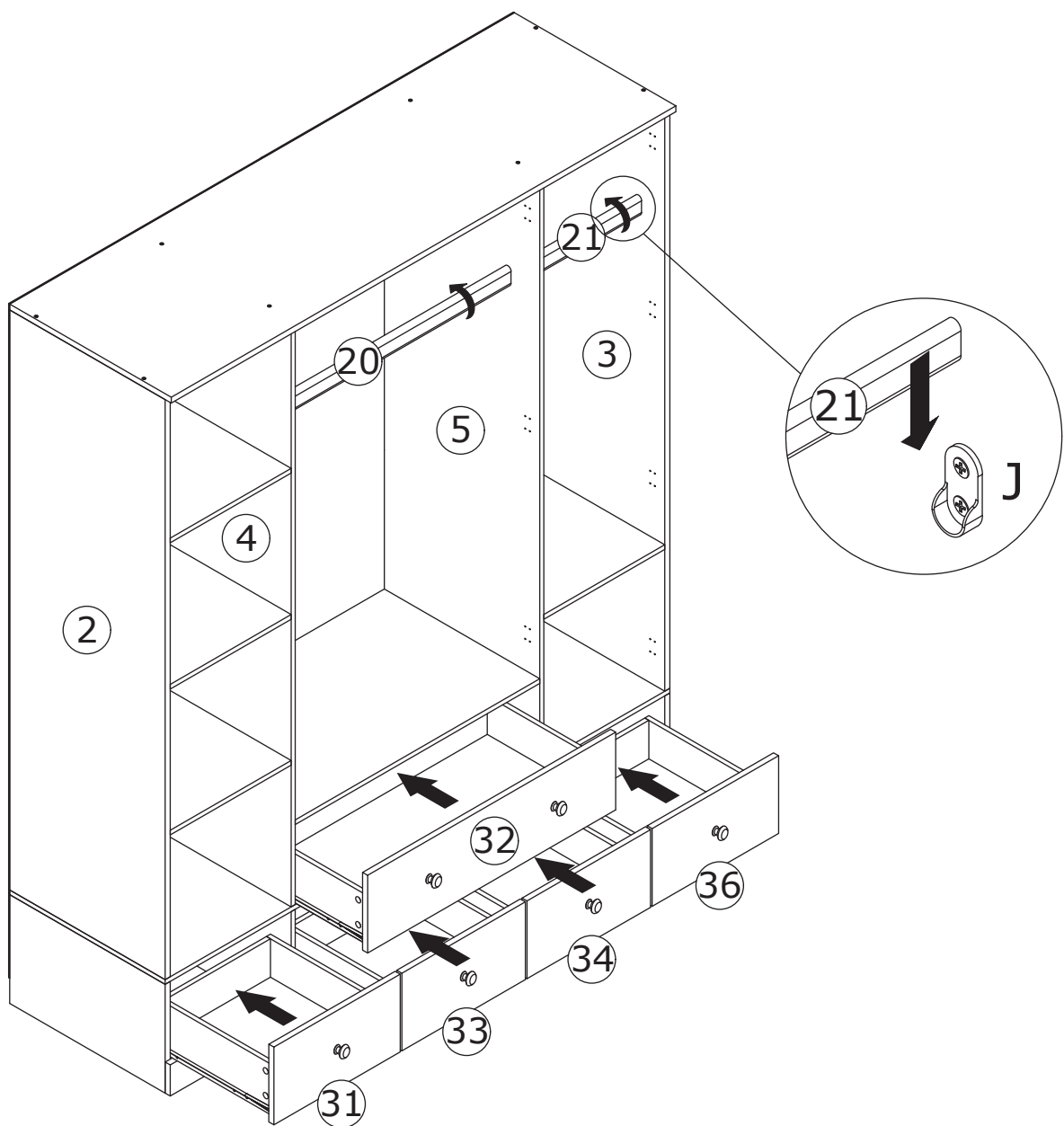
Aligner les rails, faire coulisser le tiroir.
Placer les tringles à vêtements 20 et 21 dans le tiroir.

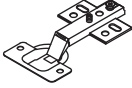

25

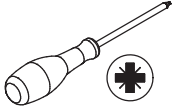
<p>F x 12</p>  <p>Ø4 x 12 mm</p>	<p>G x 6</p> 	<p>H x 2</p>  <p>Ø4 x 25 mm</p>	<p>I x 2</p> 	
---	--	--	---	---

Fix hinge(G) to plate 24 and 25 using screw(F) as shown.
Fix knob(I) to these plates using screw(H) as shown.

Befestigen Sie das Scharnier (G) mit der Schraube (F) an den Platten 24 und 25 wie gezeigt.
Den Knopf (I) mit der Schraube (H) wie abgebildet an diesen Platten befestigen.

Fixer la charnière (G) aux plaques 24 et 25 à l'aide de la vis (F) comme indiqué.
Fixer le bouton (I) à ces plaques à l'aide de la vis (H) comme indiqué.

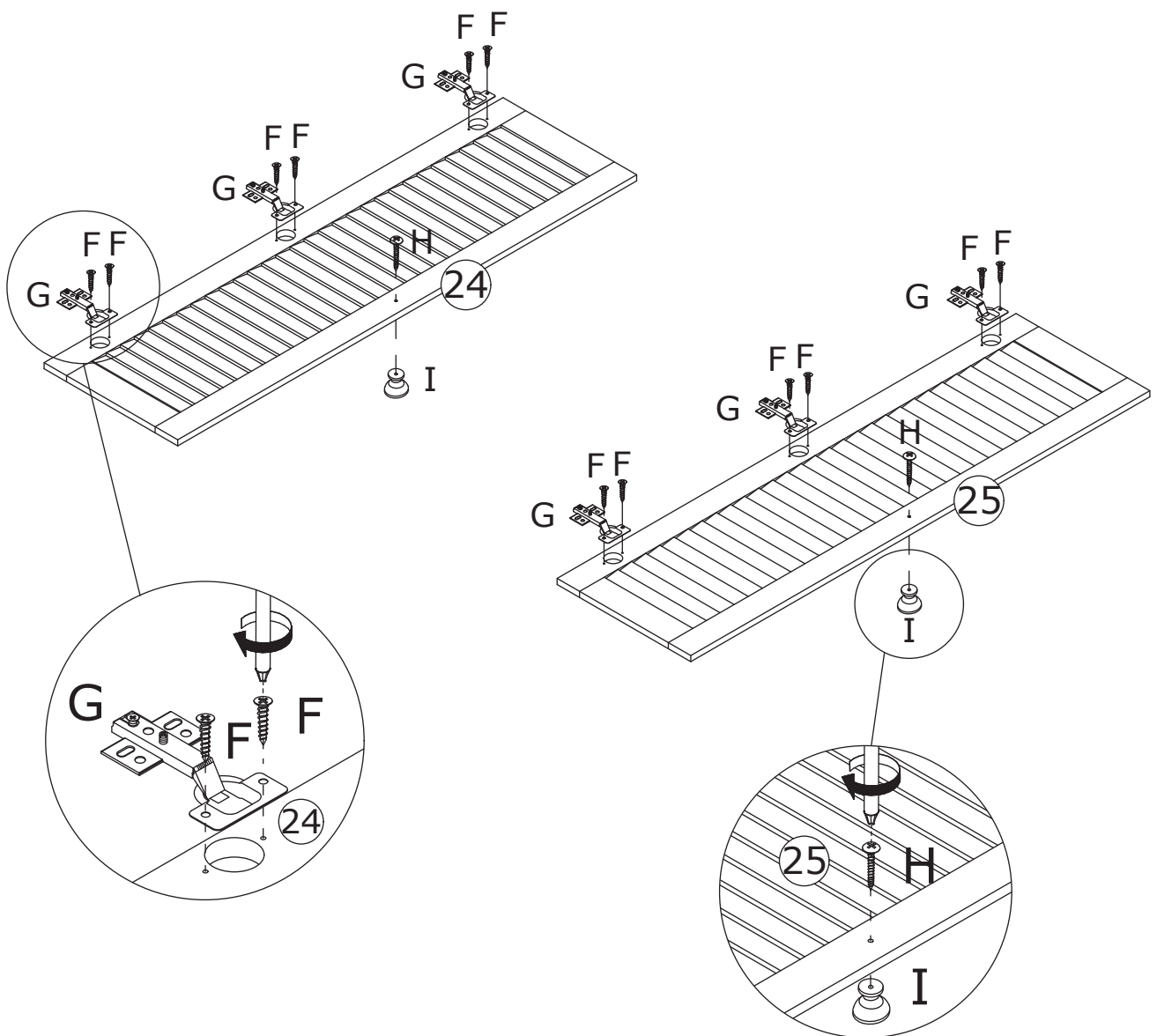

26

F x 24



Ø4 x 12 mm

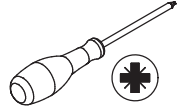



Attach door plate 24 to plate 4; door plate 25 to plate 5 by fixing hinge using screw (F) as shown.

Befestigen Sie die Türplatte 24 an Platte 4 und die Türplatte 25 an Platte 5 durch Befestigung des Scharniers mit der Schraube (F) wie abgebildet.

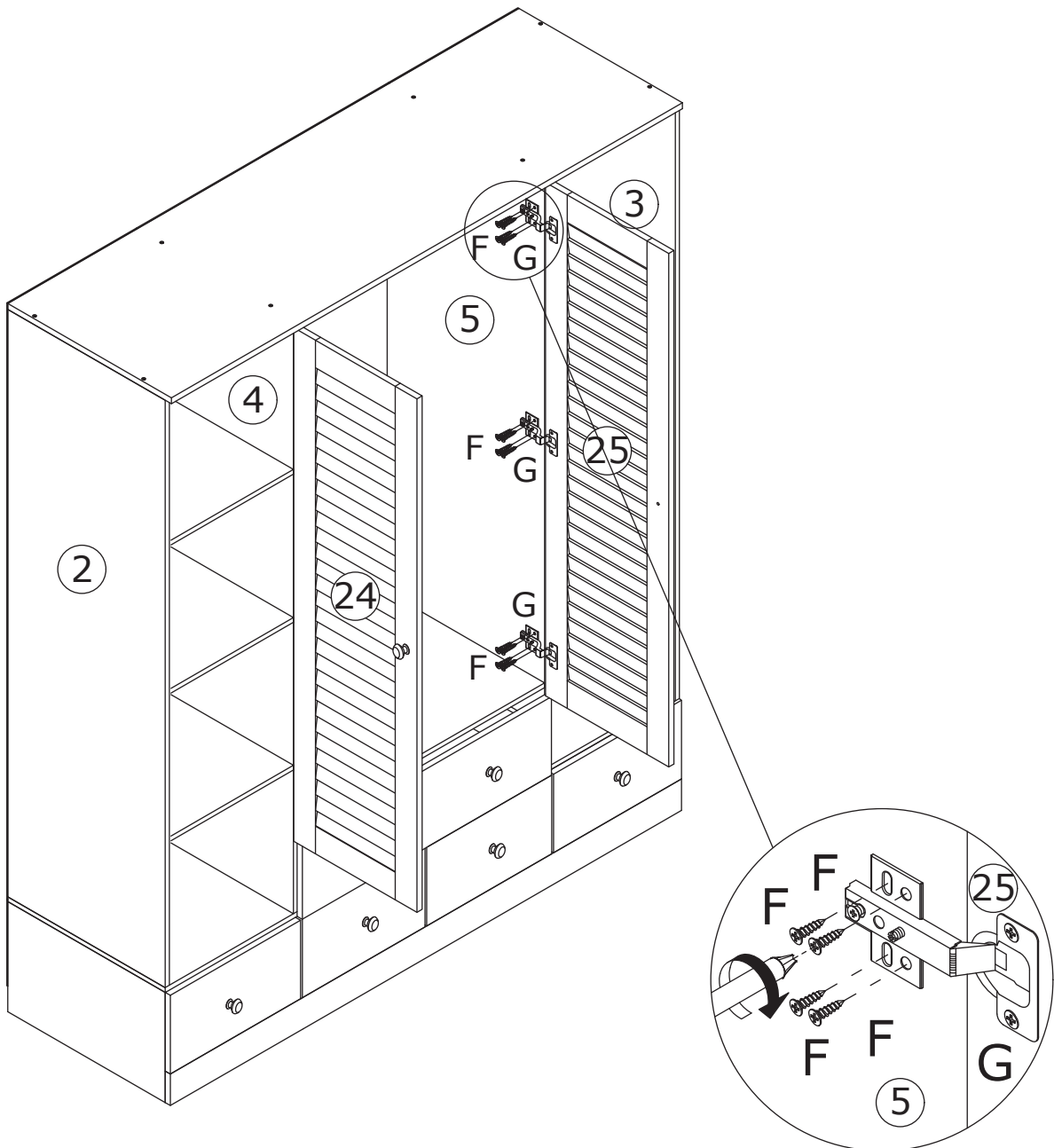
Fixer la plaque de porte 24 à la plaque 4 ; la plaque de porte 25 à la plaque 5 en fixant la charnière à l'aide de la vis (F) comme indiqué.

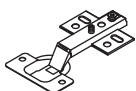

27

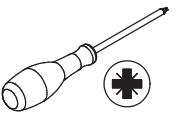
F x 16  Ø4 x 12 mm	G x 8 	H x 2  Ø4 x 25 mm	I x 2 	
---	--	--	---	---

Fix hinge(G) to plate 22 and 23 using screw(F) as shown.
Fix knob(I) to these plates using screw(H) as shown.

Befestigen Sie das Scharnier (G) mit der Schraube (F)
an den Platten 22 und 23 (siehe Abbildung).
Befestigen Sie den Knopf (I) an diesen Platten mit der
Schraube (H) wie abgebildet.

Fixer la charnière (G) aux plaques 22 et 23 à l'aide de
la vis (F) comme indiqué.
Fixer le bouton (I) à ces plaques à l'aide de la vis (H)
comme indiqué.

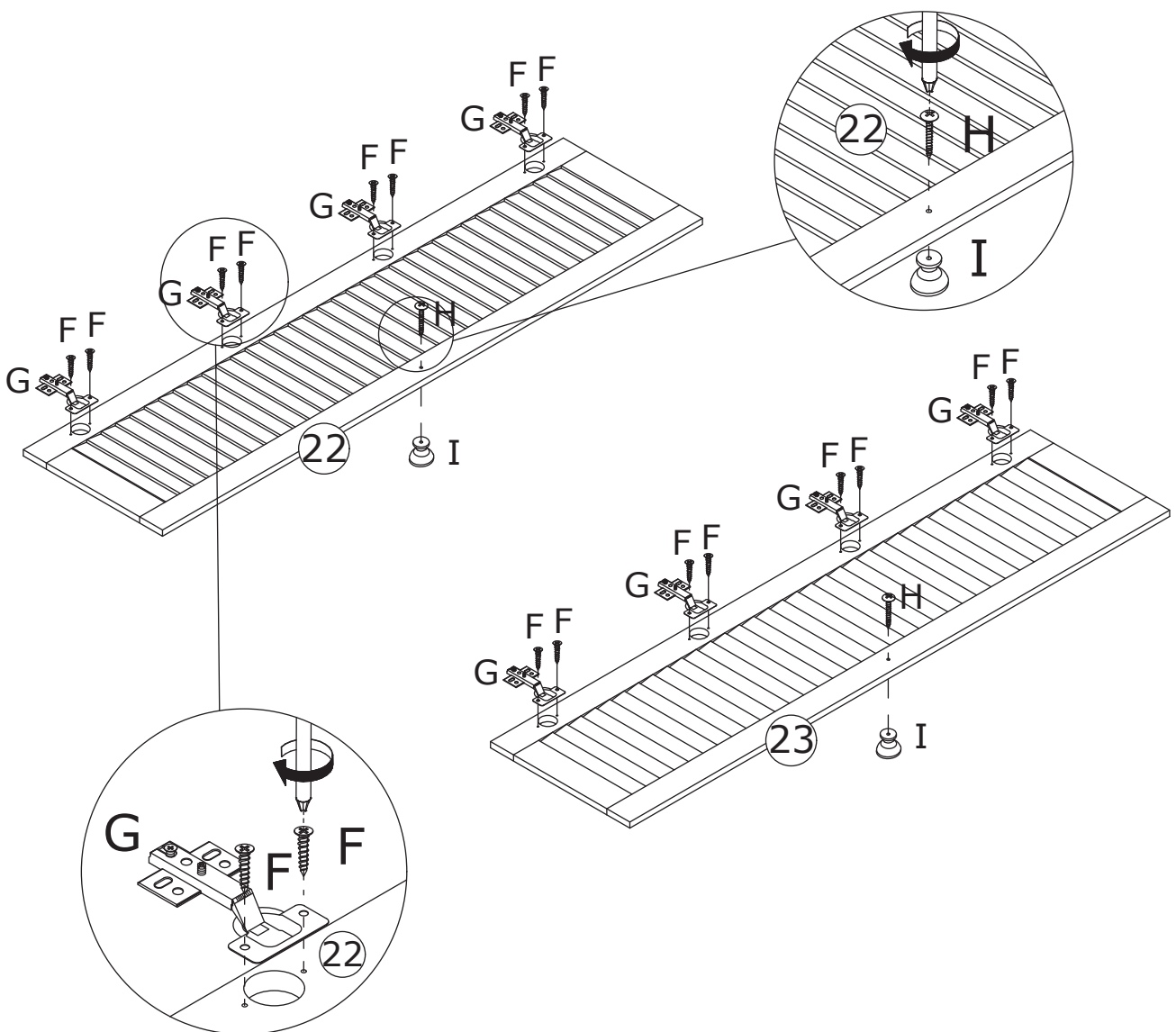

28

F x 32



Ø4 x 12 mm

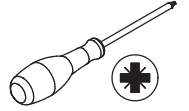

Attach door plate 22 to plate 2; door plate 23 to plate 3 by fixing hinge using screw(F) as shown.

Befestigen Sie die Türplatte 22 an Platte 2 und die Türplatte 23 an Platte 3, indem Sie das Scharnier mit der Schraube (F) wie gezeigt befestigen.

Fixer la plaque de porte 22 à la plaque 2 ; la plaque de porte 23 à la plaque 3 en fixant la charnière à l'aide des vis (F) comme indiqué.

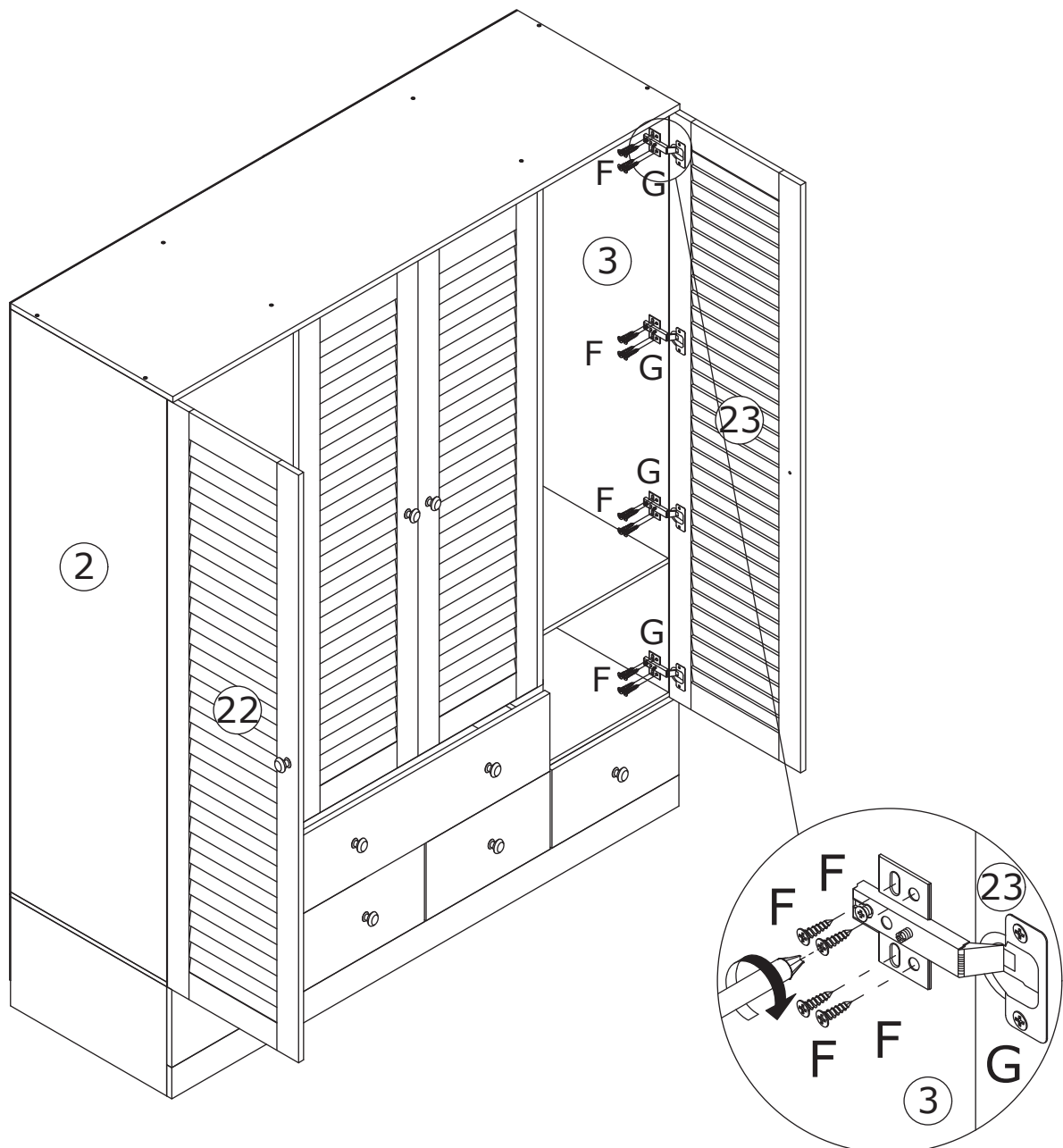

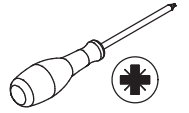

If doors are still not aligned if the hinges are properly correctly, please watch the video.

Wenn die Türen nach der korrekten Montage der Scharniere immer noch nicht ausgerichtet sind, sehen Sie sich bitte das Video an.

Si les portes ne sont toujours pas alignées alors que les charnières sont correctement posées, veuillez regarder la vidéo.

<https://youtu.be/n0Lb36SoODM>

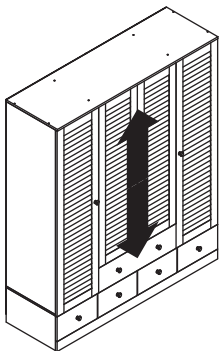
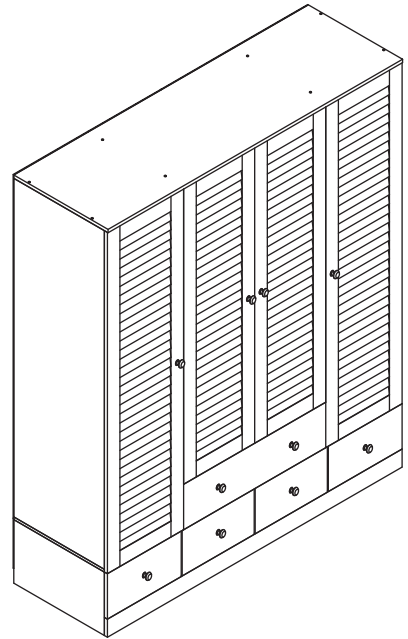

I

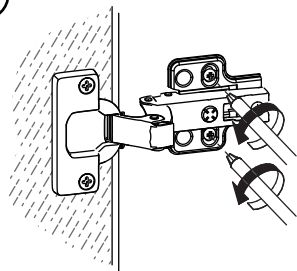

II

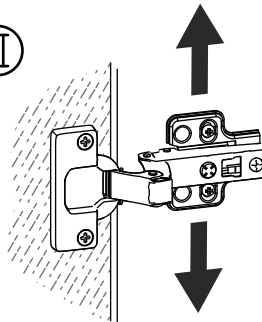

III

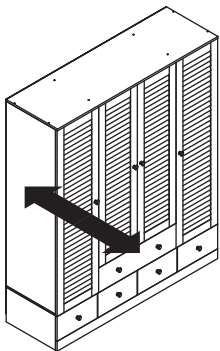
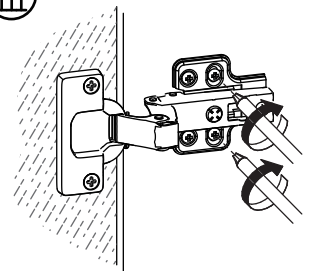

I

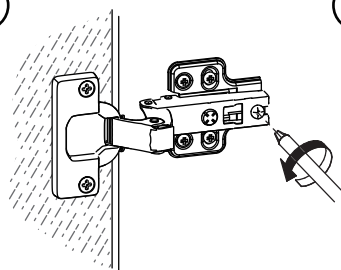

II

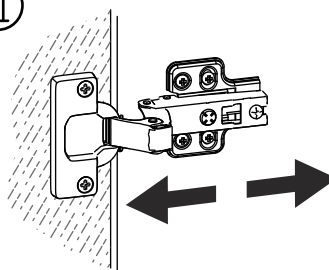

III

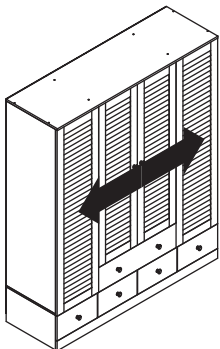
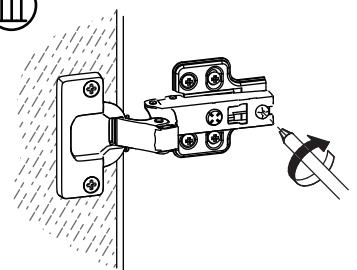

I

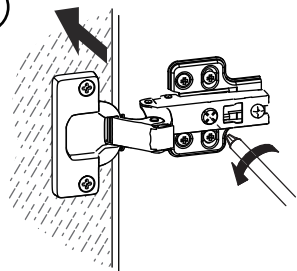

II

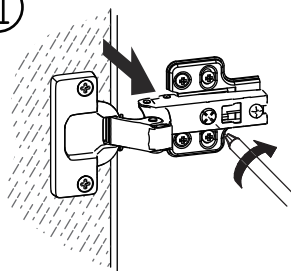

30

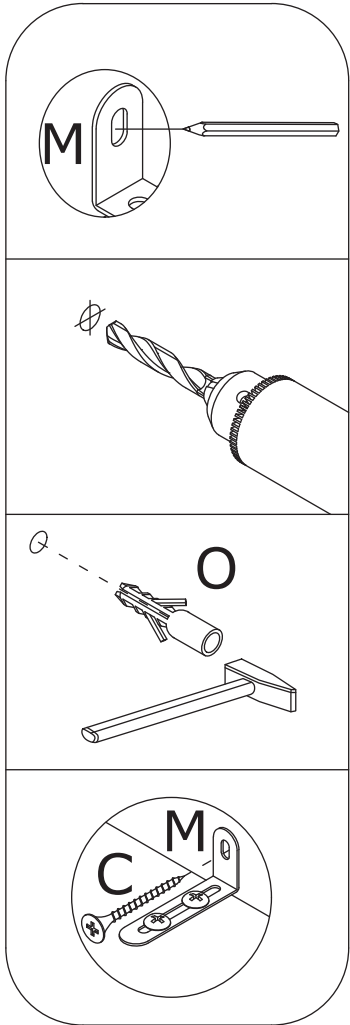
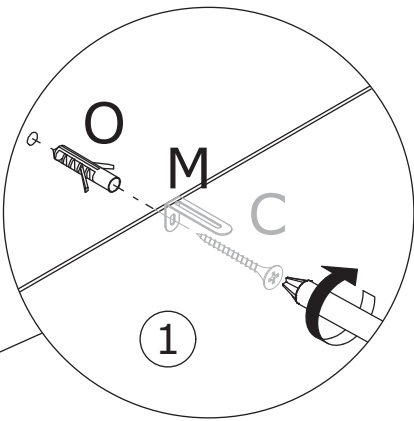
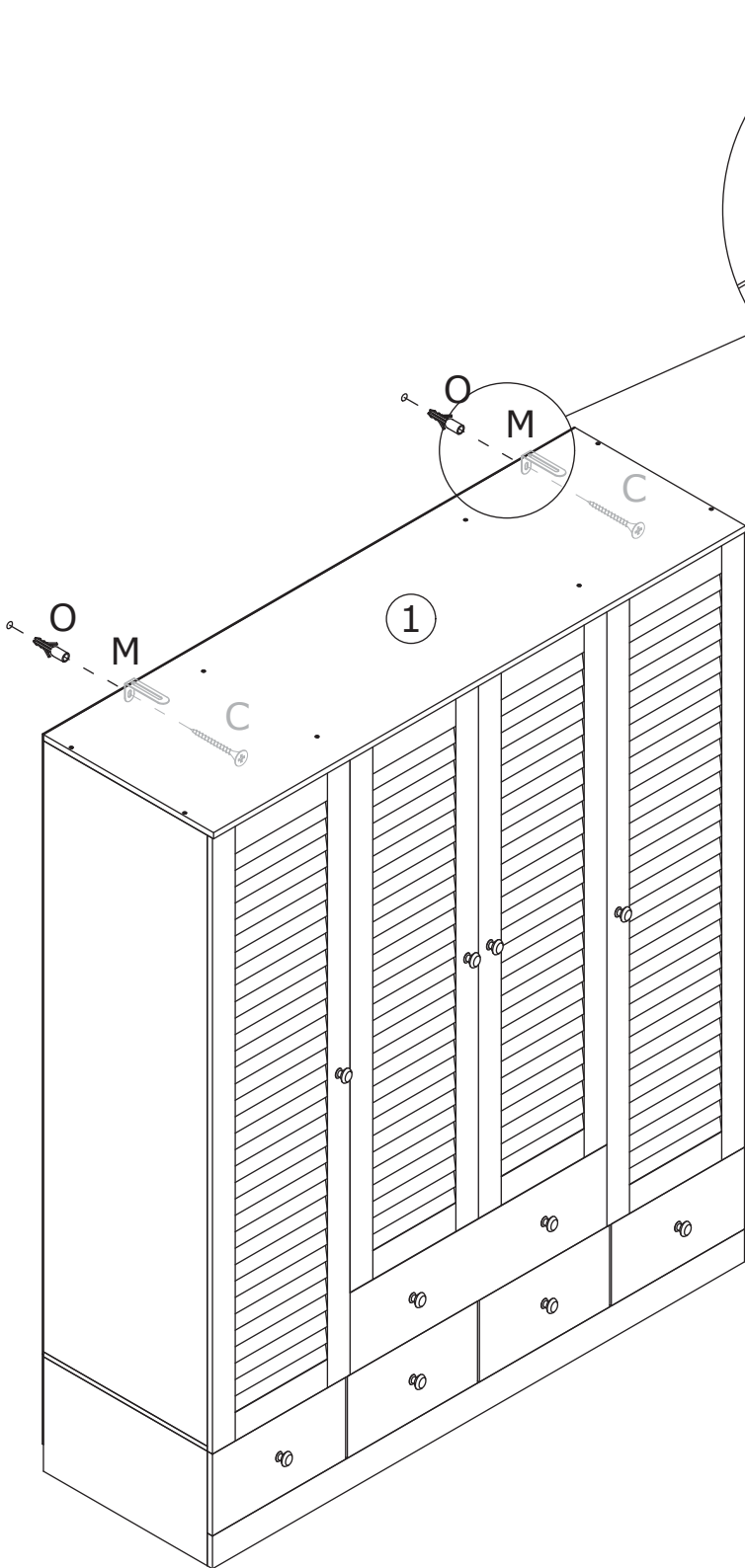
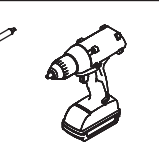
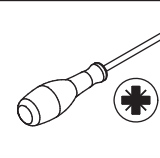
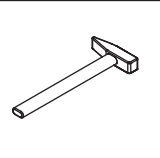
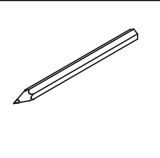
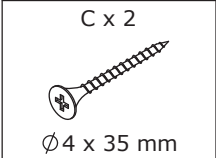

WARRANTY

WARRANTY CLAIMS

- There is a 30-day warranty for broken furniture or any other problems that do not work properly. The warranty will start from the date of purchase which must be verified by proof of purchase.
- Before making a claim, we may be able to answer your query, simply call us. Please leave your purchase order number, along with some details of the problem, if you want a replacement part. We will arrange within 48 hours. If there is out of stock, we will reply with a shipping date.
- The product must be used in accordance with the instructions provided. For health reasons.
- For other reasons, if the furniture needs to be returned, it must be cleaned and dried and operated within 30 days of receipt.

Type of Warranty Claim

- Failure to follow the furniture instructions will invalidate the warranty. Attention please.
- Does not include damage during installation, but includes damage during transportation.

Scope of responsibility

- Shall not bear any responsibility for misuse or user damage and / or loss of parts during the installation of furniture.
- After using, the damage and scratches of the furniture are not covered by the warranty.

The Warranty Relates to All Bought in The Us and Covers The Following Areas

- Sheet parts: 1 month from the date of purchase.
- Electrical parts: 1 month from the date of purchase.

GARANTIE

RÉCLAMATIONS DE GARANTIE

Il existe une garantie de 30 jours pour les meubles cassés ou tout autre problème qui ne fonctionne pas correctement. La garantie commencera à partir de la date d'achat qui doit être vérifiée par une preuve d'achat.

Avant de faire une réclamation, nous pourrions peut-être répondre à votre demande, il vous suffit de nous appeler. Veuillez laisser votre numéro de bon de commande, ainsi que quelques détails sur le problème, si vous voulez une pièce de rechange. Nous organiserons dans les 48 heures. En cas de rupture de stock, nous vous répondrons avec une date d'expédition.

Le produit doit être utilisé conformément aux instructions fournies. Pour des raisons de santé.

Pour d'autres raisons, si les meubles doivent être retournés, ils doivent être nettoyés et séchés et utilisés dans les 30 jours suivant leur réception.

Type de demande de garantie

Le non-respect des instructions du meuble annulera la garantie. Attention, s'il vous plaît. N'inclut pas les dommages pendant l'installation, mais inclut les dommages pendant le transport.

Portée de la responsabilité

N'assume aucune responsabilité en cas de mauvaise utilisation ou de dommages causés par l'utilisateur et / ou de perte de pièces lors de l'installation du meuble.

Après utilisation, les dommages et rayures du meuble ne sont pas couverts par la garantie.

La garantie s'applique à tous les produits achetés aux États-Unis, dans tous les pays d'Europe et couvre les domaines suivants:

Pièces en tôle: 1 mois à compter de la date d'achat.

Pièces électriques: 1 mois à compter de la date d'achat..

GARANTIE

GEWÄHRLEISTUNGSANSPRÜCHE

Es gibt eine 30-tägige Garantie für kaputte Möbel oder andere Probleme, die nicht richtig funktionieren. Die Garantie beginnt mit dem Kaufdatum, das verifiziert durch Kaufbeleg.

Bevor Sie einen Anspruch geltend machen, können wir Ihre Anfrage möglicherweise beantworten. Rufen Sie uns einfach an. Bitte hinterlassen Sie Ihre Bestellnummer zusammen mit einigen Details des Problems, wenn Sie ein Ersatzteil wünschen. Wir werden innerhalb von 48 Stunden arrangieren. Wenn es nicht vorrätig ist, werden wir mit einem Versanddatum antworten.

Das Produkt muss gemäß den mitgelieferten Anweisungen verwendet werden.

Wenn die Möbel aus anderen Gründen zurückgegeben werden müssen, müssen sie innerhalb von 30 Tagen nach Erhalt gereinigt, getrocknet und in Betrieb genommen werden.

Art des Garantieanspruchs

Die Nichtbeachtung der Möbelanweisungen führt zum Ausfall der Garantie. Bitte beachten Sie. Beinhaltet keine Schäden während der Installation, aber Schäden während des Transports.

Verantwortungsbereich

Übernimmt keine Verantwortung für Missbrauch oder Benutzerschäden und / oder Verlust von Teilen während der Installation von Möbeln.

Nach dem Gebrauch sind die Schäden und Kratzer der Möbel nicht von der Garantie abgedeckt.

Die Garantie bezieht sich auf alle in den USA und Europa gekauften und deckt die folgenden Bereiche ab

Blechteile: 1 Monat ab Kaufdatum.

Elektrische Teile: 1 Monat ab Kaufdatum.

RETURNS

CHANGED YOUR MIND AND NEED TO RETURN YOU ITEM?

PLEASE FOLLOW THE BELOW INSTRUCTIONS:

- If you have purchased and have simply changed your mind, follow the retailer's instructions for returns.

DEFECTIVE ITEMS

- If your item is defective in any way, i.e. it doesn't work but you can't identify why, in the first instance, please call us.

DAMAGED ITEMS

- If you receive an order with obvious shipping damage from the retailer, then we suggest the delivery is refused. If the delivery has been accepted and then shipping damage is found, please follow the specific instructions advised by the retailer. In all circumstances please save all packaging material and paperwork for the order. Please be aware that if you dispose of packaging material or attempt to return the merchandise without contacting the fulfiller, you jeopardise your chances of making a claim, and you may not receive a credit for the return.

AFTER-SALES CONTACT



feedbackstation@163.com



(303)800-6387

RETOUR

VOUS AVEZ CHANGE D'AVIS ET VOUS AVEZ BESOIN DE RETOURNER VOTRE ARTICLE ?

VEUILLEZ SUIVRE LES INSTRUCTIONS CI-DESSOUS:

Si vous avez acheté et que vous avez simplement changé d'avis, suivez les instructions du détaillant pour les retours.

ARTICLES DÉFECTUEUX

Si votre article est défectueux de quelque manière que ce soit, c'est-à-dire qu'il ne fonctionne pas, mais que vous ne pouvez pas identifier pourquoi, en premier lieu, veuillez nous appeler.

ARTICLES ENDOMMAGÉS

Si vous recevez une commande avec des dommages d'expédition évidents du détaillant, nous suggérons que la livraison soit refusée. Si la livraison a été acceptée et que des dommages d'expédition sont constatés, veuillez suivre les instructions spécifiques conseillées par le détaillant.

Dans tous les cas, veuillez conserver tout le matériel d'emballage et les documents pour la commande.

Veuillez noter que si vous vous débarrassez du matériel d'emballage ou tentez de retourner le

Marchandise Sans contacter le remplisseur, vous compromettez vos chances de faire une réclamation, et vous ne pouvez pas recevoir de crédit pour le retour.



Rücksendung

SIE HABEN IHRE MEINUNG GEÄNDERT UND MÜSSEN IHREN ARTIKEL ZURÜCKGEBEN?

BITTE BEFOLGEN SIE DIE FOLGENDEN ANWEISUNGEN:

Wenn Sie gekauft haben und einfach Ihre Meinung geändert haben, befolgen Sie die Anweisungen des Händlers für die Rückgabe.

DEFEKT EARTIKEL

Wenn Ihr Artikel in irgendeiner Weise defekt ist, d.h. es funktioniert nicht, aber Sie können nicht erkennen, warum in erster Instanz, rufen Sie uns bitte an.

BESCHÄDIGTE ARTIKEL

Wenn Sie vom Händler eine Bestellung mit offensichtlichen Transportschäden erhalten, schlagen wir vor, die Lieferung abzulehnen. Wenn die Lieferung angenommen wurde und ein Transportschaden festgestellt wird, befolgen Sie bitte die spezifischen Anweisungen des Händlers. Bitte bewahren Sie in jedem Fall alle Verpackungsmaterialien und Papiere für die Bestellung auf.

Bitte beachten Sie, dass Sie Ihre Chancen auf eine Reklamation gefährden, wenn Sie Verpackungsmaterial verlieren oder versuchen, die Ware zurückzusenden, ohne sich den Kundendienst zu kontaktieren, und dass Sie möglicherweise keinen Betrag für die Rücksendung erhalten.

Hinweis: Die Waren müssen in der Originalverpackung, vollständig und in unbenutztem und unbeschädigtem Zustand an den Verkäufer zurückgeschickt werden.

