



▼ Model:  
**ZH3002S**

# Premium Stainless Steel 3-Burner Gas/Charcoal Grill Combo OWNER'S MANUAL

Series No.: 1104-C



## Customer Service

📞 1-800-618-6798

### FOR YOUR SAFETY!

Use outdoors only! Do not use it inside a building, garage, or any other enclosed space. Read the instructions before assembling and using the appliance.

DO NOT use the grill unless it is completely assembled, and all the parts are securely fastened. This grill will become very hot, do not move it during use. Keep away from children and pets.

### CONTACT US FIRST!

This grill has been made to high quality standards.

If you have any questions that are not addressed in this Owner's Manual, or you need parts, please call our customer service hotline or send an email to [service@royalgourmetusa.com](mailto:service@royalgourmetusa.com)

Please keep this Owner's Manual for future reference.

Learn more at:

[www.royalgourmetcorp.com](http://www.royalgourmetcorp.com)

<b>For Your Safety</b> .....	<b>2-3</b>
<b>Parts Diagram</b> .....	<b>4</b>
<b>Parts and Hardware List</b> .....	<b>5</b>
<b>Preparation</b> .....	<b>6</b>
<b>Assembly Instructions</b> .....	<b>7-13</b>
<b>General Information and Instructions</b> .....	<b>14</b>
LP Gas and Cylinder Information .....	<b>14</b>
Cylinder Specifications .....	<b>15</b>
LP Cylinder Leak Test .....	<b>16-17</b>
<b>Operating Instructions</b> .....	<b>18</b>
<b>Cleaning and Maintenance</b> .....	<b>19-20</b>
<b>Troubleshooting Guide</b> .....	<b>21-22</b>
<b>Grilling Recipes</b> .....	<b>23-24</b>
<b>Warranty and Customer Service</b> .....	<b>25</b>

1. DO NOT store or use gasoline, or any flammable vapors and liquids within 8 meters (25 feet) of the grill.
2. When cooking with oil/grease, do not allow the oil/grease to exceed 177 °C (350 °F).  
DO NOT store extra cooking oil in the vicinity of the grill.
3. The liquid propane (LP) tank (cylinder) not connected for use should be stored at a minimum of 3 meters (10 feet) distance from the grill or any appliance.  
Never fill the LP gas cylinder beyond 80 percent capacity. If the above instructions are not followed exactly, there is risk of fire that may cause serious injury or death.

In case of any issue, call us first! **DO NOT** return the grill to the retailer. This grill has been made to high quality standards. If you have any questions not addressed in this user's manual, or you need parts, please call our customer service hotline.

**NOTE:** The assembly and use of this grill must conform to local codes. In the absence of local codes, use the National Gas and Propane Instruction Code. Read all instructions prior to assembly and use.

### **CAUTION:**

1. This grill is meant for use with propane gas only (propane gas cylinder not included).
2. Never attempt to attach this grill to the self-contained propane system of a camper trailer, motor home, or house.
3. Never use charcoal or lighter fluid with gas grills.
4. DO NOT use gasoline, kerosene, or alcohol for lighting. The LP gas supply cylinder to be used must be constructed and marked in accordance with the specifications for LP Gas cylinder of the U.S. Department of Transportation (DOT) or the National Standard of Canada, CAN/CSA-B339, Cylinders, Spheres and Tubes for Transportation of Dangerous Goods and Commission. This grill is not intended to be used in or on recreational vehicles or boats.
5. DO NOT attempt to move the grill while it is lit or hot.
6. DO NOT use the grill unless it is completely assembled, and all parts are securely fastened and tightened.
7. DO NOT use the grill or any gas products near unprotected combustible buildings and materials.
8. DO NOT use in the presence of gases or vapors. Keep the grill area clear and free from combustible materials, gasoline, and other flammable vapors and liquids.
9. DO NOT touch metal parts of the grill until it has completely cooled (about 45 minutes) to avoid burns, unless you are wearing protective gear (oven mitts, potholders, etc.).
10. DO NOT alter the grill in any manner.
11. Keep all combustible items and surfaces at least 91 cm (36 inches) from the grill at all times.
12. Clean and inspect the hose before each use. If there is evidence of abrasion, wear, cuts, or leaks, the hose must be replaced before operating the grill. The replacement hose assembly must be as per the manufacturer specifications specified by the manufacturer.
13. Move the gas hose as far away as possible from hot surfaces and dripping hot grease.
14. Never keep a filled LP gas cylinder in a hot car or truck. Heat will may cause the gas pressure to increase, which may open cause the relief valve to open and allow the gas to escape.
15. Keep the grill's valve compartment, burners, and circulating air passages clean. Inspect the grill before each use.

## WARNING:

1. This grill is for outdoor use only and should not be used inside a building, garage, or any other enclosed space.
2. The consumption of alcohol, prescription, or non-prescription drugs may impair the operators' ability to properly assemble or safely operate the grill.
3. Always open the grill lid slowly and carefully as heat and steam trapped within the grill can cause severe burns.
4. Always place your grill on a hard and level surface far away from combustibles.
5. Do not leave a lit grill unattended. ALWAYS keep children and pets away from the grill.
6. Do not place the grill on any type of tabletop surface.
7. Do not use the grill in high winds.
8. Do not use the grill to cook excessively fatty meat or other fatty or greasy food where there is risk of flare-ups.

## DANGER:

Liquid propane gas is flammable and hazardous if handled improperly. Understand the characteristics before using any propane product.

1. Propane characteristics: Flammable, explosive under pressure, heavier than air, settles in pools and low areas.
2. In its natural state, propane has no odor. For your safety, an odorant has been added.
3. Contact with propane can cause freeze burns to the skin.
4. This grill is shipped from the factory for use with propane gas only.
5. Never use a propane cylinder with a damaged body, valve, collar, or footing.
6. Dented or rusted propane cylinders may be hazardous and should be checked by your propane gas supplier.

### FOR YOUR SAFETY

1. The minimum distance around the grill that must be kept free of combustible materials is 90 cm (36 inches), which includes the walls of buildings or building features.
2. Do not place the grill where there are combustible surfaces overhead.

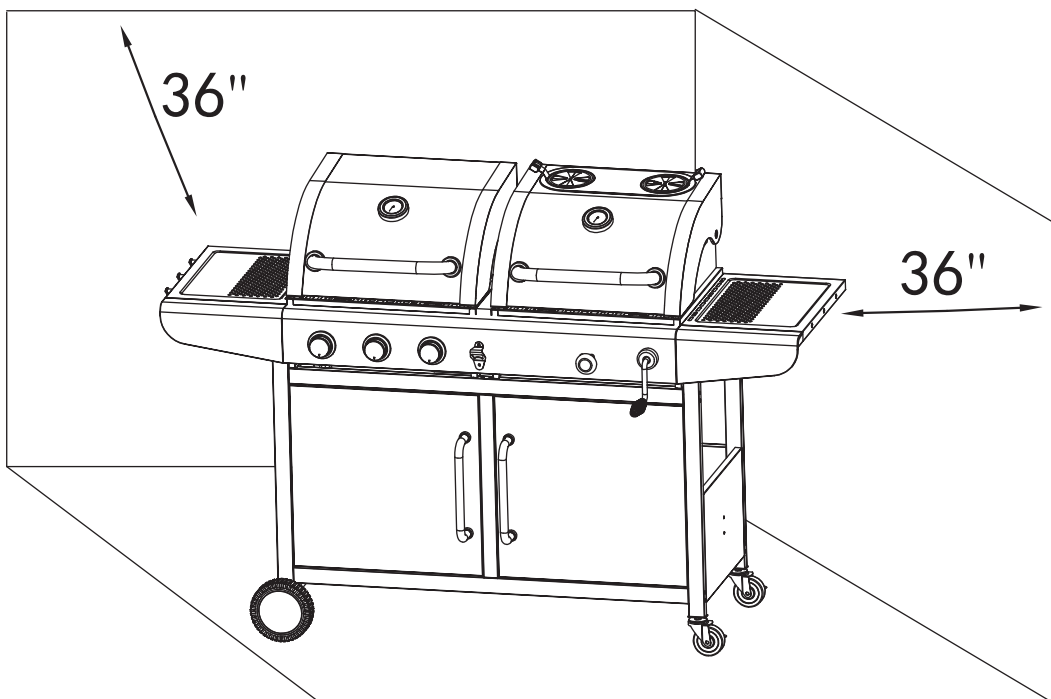

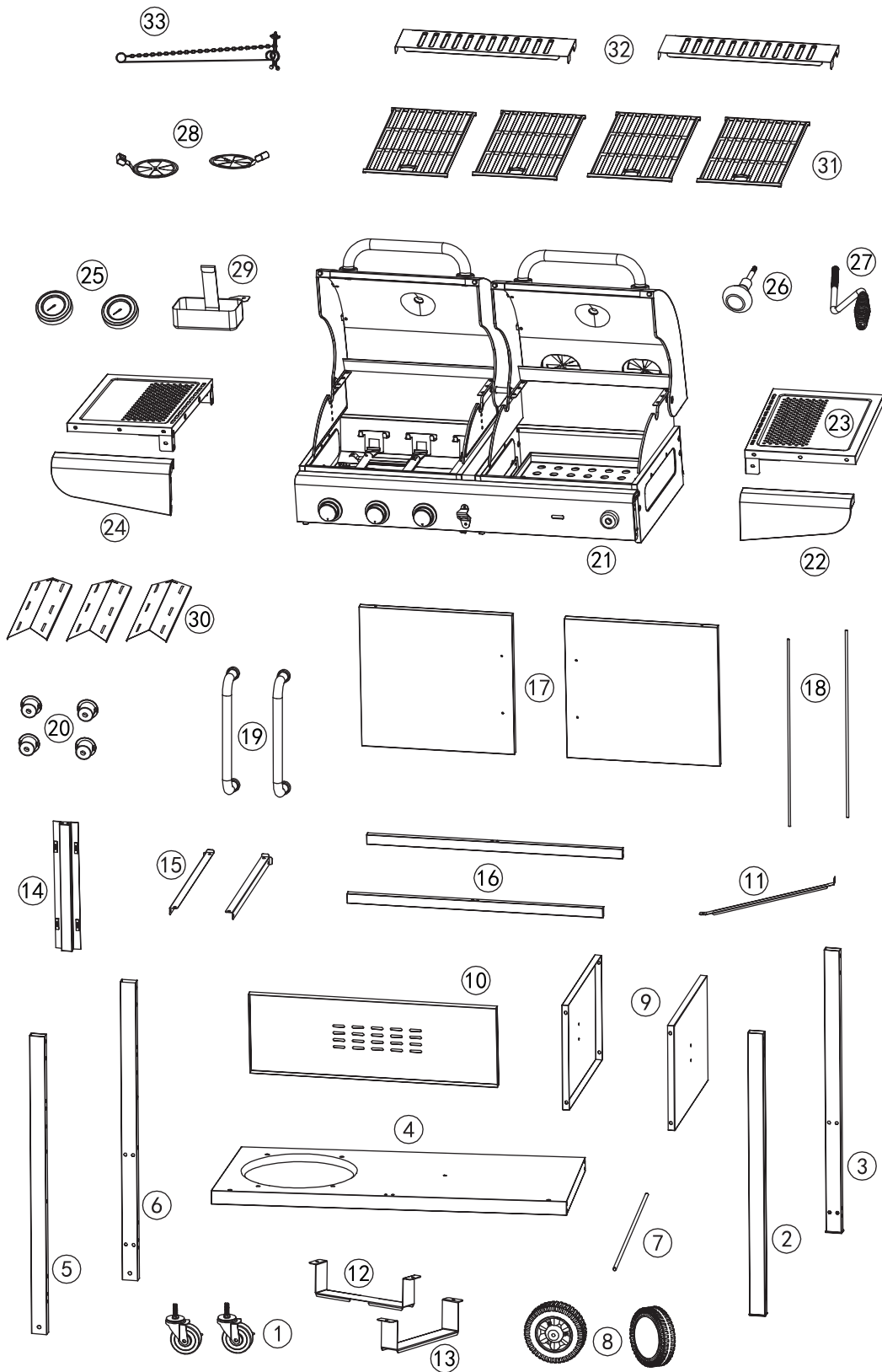

Ref	Description	Illustration	QTY
1.	Caster W-20130008		2
2.	Right front leg H-20130007		1
3.	Right back leg H-20130008		1
4.	Bottom shelf Z-ZH2303035		1
5.	Left front leg Z-20130003		1
6.	Left back leg Z-20130001		1
7.	Wheel axle W-20130023		1
8.	Wheel & Rim cover W-20130010 W-20130009		2
9.	Side panel Z-ZH2303040		2
10.	Rear panel Z-ZH2302015		1
11.	LP tank barrier bar Z-LG600029		1
12.	LP tank brace (upper) Z-A3127-RGC		1
13.	LP tank brace (lower) Z-A3128-RGC		1
14.	Cabinet center stile Z-ZH2302016		1
15.	Cart side beam Z-20130017		2
16.	Cart beam H-ZH2302005		2
17.	Door Z-ZH2303036 Z-ZH2303037		2

Ref	Description	Illustration	QTY
18.	Door axle W-20130024		2
19.	Door handle W-53650003		2
20.	Handle sleeve W-A0403		4
21.	Main body		1
22.	Right decoration board Z-51130002		1
23.	Side table Z-ZH2303043		2
24.	Left decoration board Z-51130001		1
25.	Thermometer W-20130020		2
26.	Damper knob W-DXL12021 W-DXL12022		1
27.	Crank handle W-ZH2302002 W-R3005		1
28.	Damper W-ZH300101 Z-ZH300104		2
29.	Grease cup W-20130025		1
30.	Flame tamer Z-ZH2303044		3
31.	Cooking grate W-52930002		4
32.	Warming rack Z-20120019		2
33.	Ignition match W-GD430011		1

A	M5x55	22 pcs	B	M5x10	28 pcs	C	M4x8	2 pcs	D	Split pin	3 pcs	E	Washer	2 pcs
F	Door pin cap	2 pcs	G	M5	1 pc	H	M6x12	8 pcs	I	M6x34	3 pcs	J	Washer	2 pcs

Before beginning assembly, make sure all parts are present. Compare parts with packaged contents list and diagram above. If any parts are missing or damaged, do not attempt to assemble the products. Contact customer service for replacement parts via telephone or email.



Phillips screwdriver



Wrench

- Estimated assembly time: 40 minutes
- Tools required for assembly:  
Phillips Screwdriver (not included) and Wrench (not included)
- Note: The right and left sides of the grill are designed as if you are facing the front of the grill.



### **CALIFORNIA PROPOSITION 65 WARNING**

1. Fuels used in charcoal and gas burning appliances and the combustion byproducts of such fuels, can expose you to chemicals including carbon black, which is known to the State of California to cause cancer, carbon monoxide, which is known to the State of California to cause birth defects or other reproductive harm.
2. This product can expose you to chemicals including nickel, which is known to the State of California to cause cancer. Handling the brass material on this product can expose you to lead, a chemical known to the State of California to cause cancer, birth defects or other reproductive harm.

For more information go to: [www.P65Warnings.ca.gov](http://www.P65Warnings.ca.gov)

Step 1

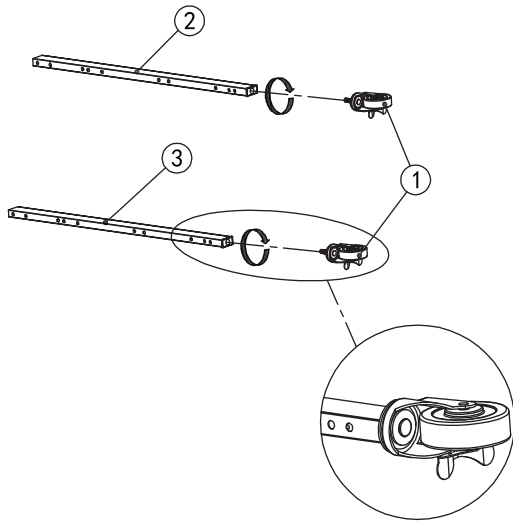

Assemble 2 casters (1) to the right legs (2), (3) by twisting clockwise.

Step 2

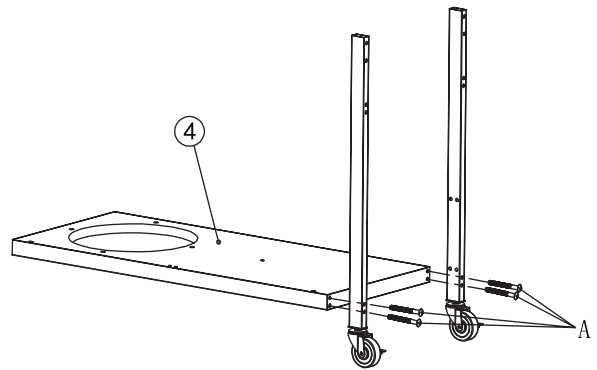

Assemble the right legs to the right side of the bottom shelf (4) with 4 bolts (A).  
Please note: At this point, hand-tighten the bolts.

Step 3

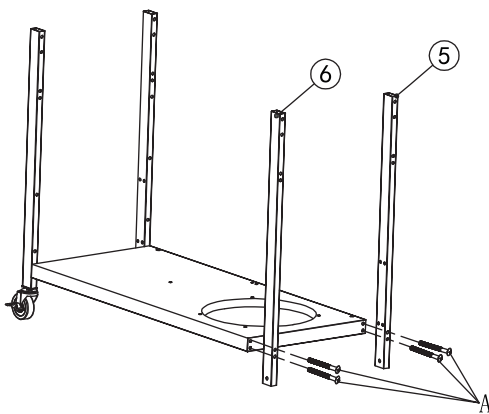

Assemble the left legs (5), (6) to the bottom shelf with 4 bolts (A).  
Please note: At this point, hand-tighten the bolts.

Step 4

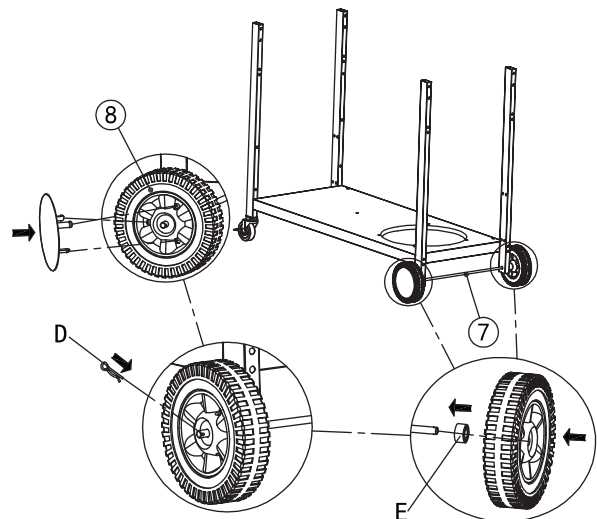

Slide the wheel axle (7) through the lower holes of the left leg assembly. Attach the wheel washer (E) and wheels (8) on the axle from both ends. Secure each wheel with a split pin (D). Attach the wheel rim covers back to the wheels.

Step 5

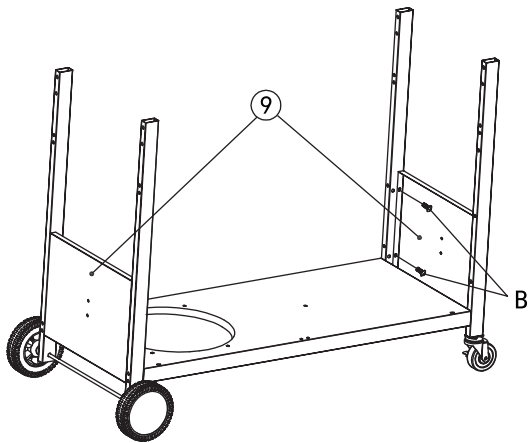

Assemble 2 side panels (9) to the lower holes of the left and right leg assemblies respectively with 8 bolts (B).

Step 6

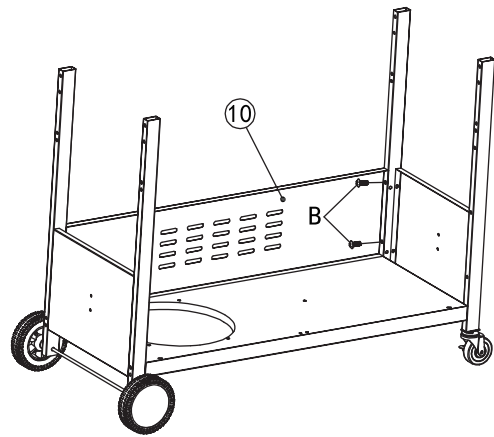

Assemble the rear panel (10) to the lower holes of back legs with 4 bolts (B).  
Please note: At this point, tighten all the bolts using a screwdriver.

Step 7

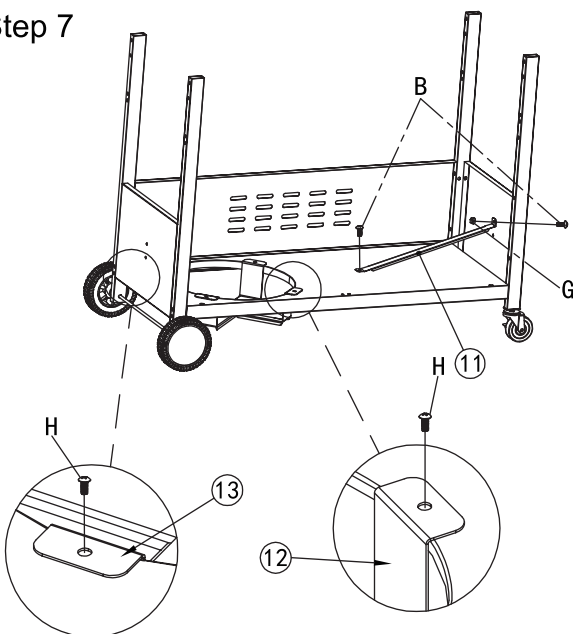

Secure one end of the LP tank barrier bar (11) to the hole on the right side panel with 1 bolt (B) and 1 nut (G), and fix the other end to the bottom shelf (2) with 1 bolt (B).  
First, fix the lower LP tank brace (13) to the nesting hole with 2 bolt (H). Then, fix the upper LP tank brace (12) to the nesting hole above the upper base with 2 bolt (H).

Step 8

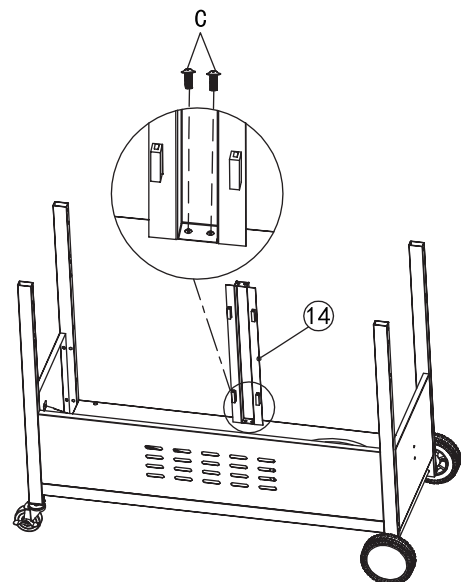

Assemble the cabinet center stile (14) to the bottom shelf with 2 bolts (C).

Step 9

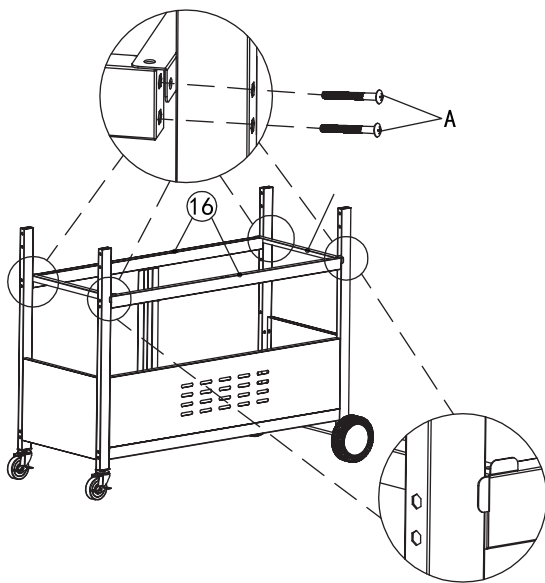

Assemble cart beams (16) and side beams (15) to the legs by 8 bolts (A).  
Please note: Ensure that cart side beams are attached between the legs and cart beams.

Step 10

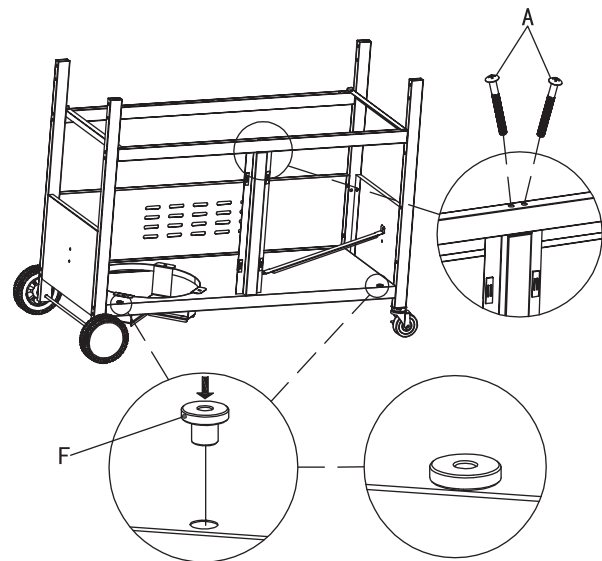

Insert two door pin caps (F) to the corresponding holes on the bottom shelf as shown.  
Fix the cabinet center stile with the cart front beam with 2 bolts (A).

Step 11

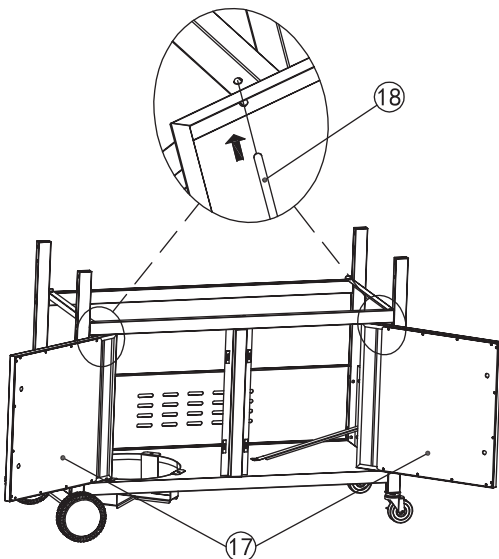

Install the doors (17) to the cart by inserting one end of the door axles (18) into the holes on the upper cart front beam, and the other end into the door pin cap on the bottom shelf.

Step 12

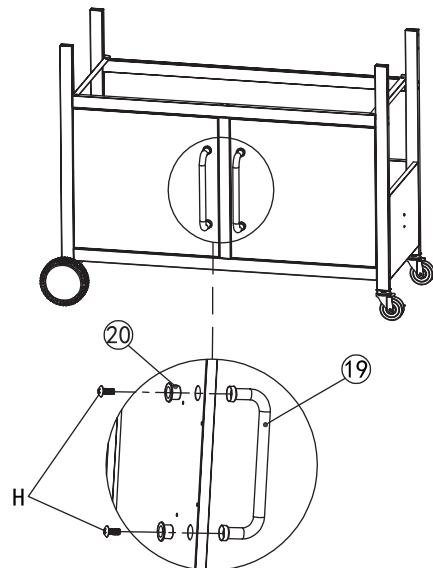

Assemble two door handles (19) and door sleeves (20) to doors with 4 bolts (H).

Step 13

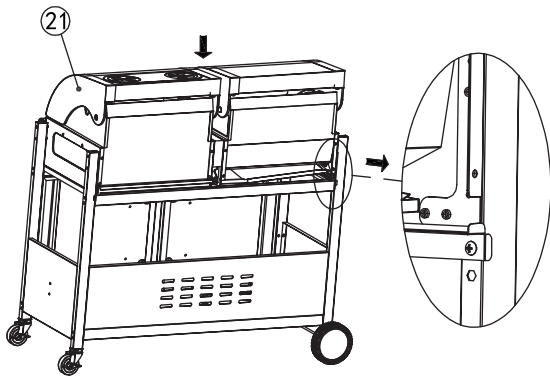

Align and place the main body (21) onto the cart.

Step 14

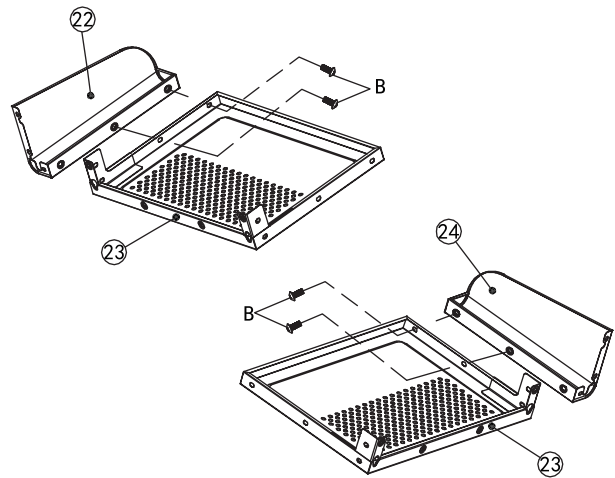

Assemble the decoration boards (23), (24) to side tables (23) with 4 bolts (B).

Step 15

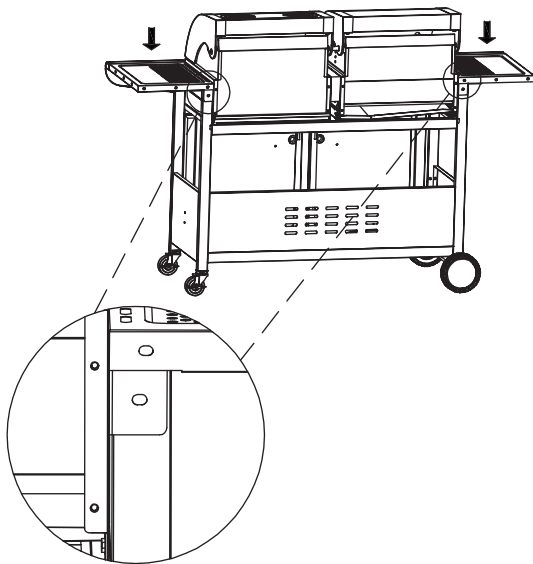

Attach the side table assemblies to both sides of the grill as shown.

Step 16

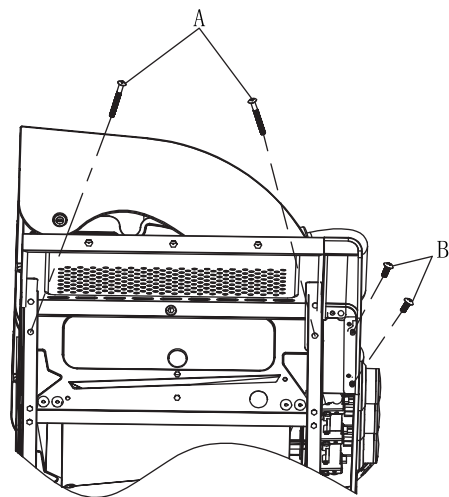

Reinforce the left side table with the main body with 2 bolts (A).  
Reinforce the left decoration board to the control panel with 2 bolts (B).

Step 17

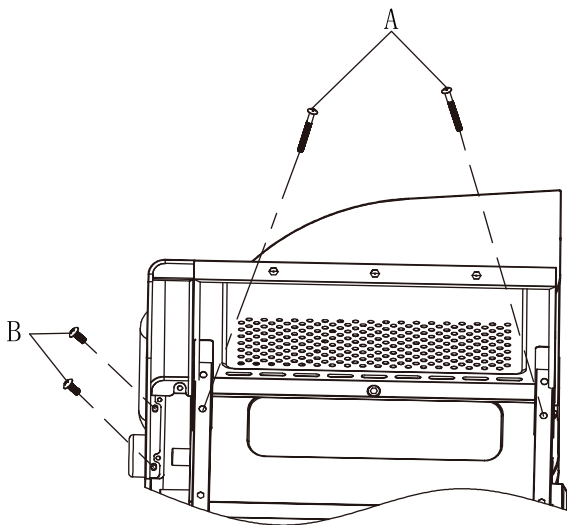

Reinforce the right side table with the main body with 2 bolts (A).  
Reinforce the right decoration board to the control panel with 2 bolts (B).

Step 18

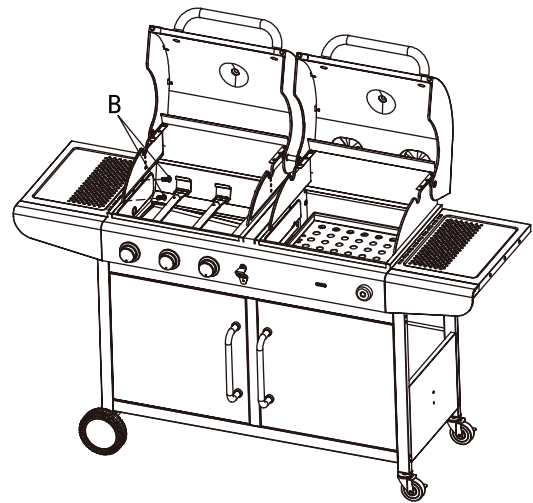

Fasten the side table assemblies from the inside of the main body with 4 bolts (B).

Step 19

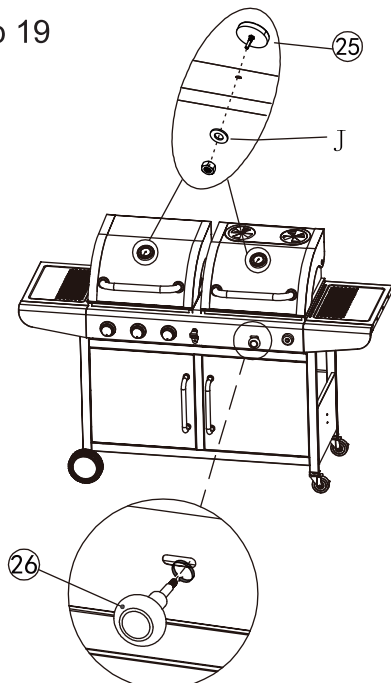

Install 2 thermometers (25) to the lids with 2 washers (J) and nuts.  
Screw the damper knob (26) to the corresponding slot on the control panel by twisting clockwise.

Step 20

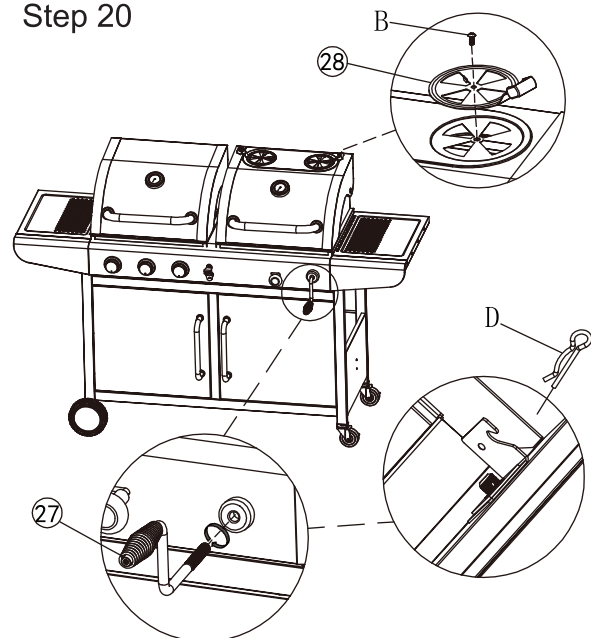

Install the dampers (28) to the charcoal lid with 2 bolts (B).  
Screw the crank handle (27) to the corresponding hole on the control panel by twisting clockwise, and secure it with 1 split pin (D).

Step 21

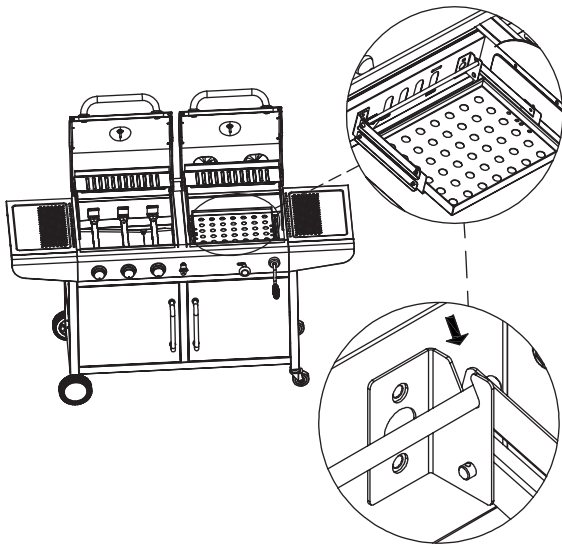

Adjust the charcoal pan to the right position as shown.

Step 22

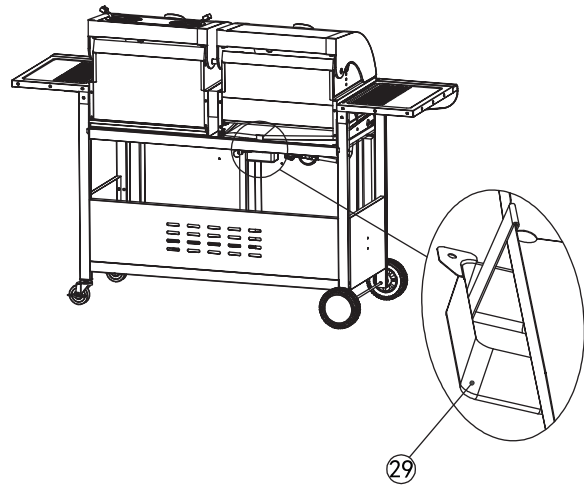

Hang the grease cup (29) to the corresponding hole underneath the main body.

Step 23

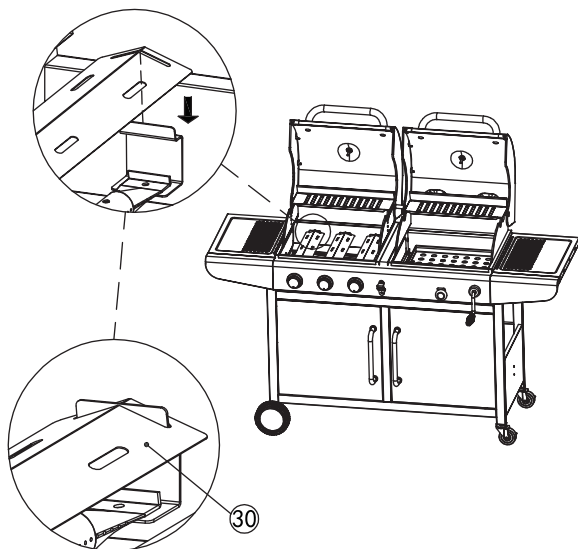

Place the flame tamers (30) into the left firebox.

Step 24

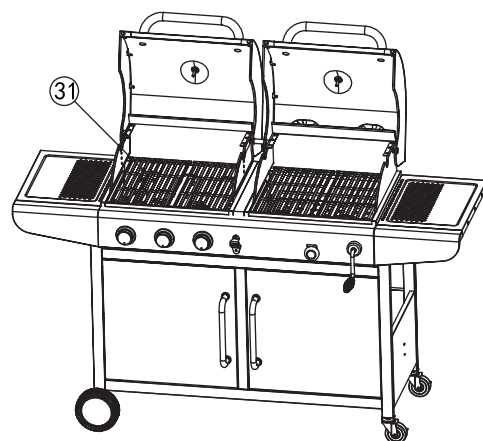

Place the cooking grates (31) into both fireboxes.

Step 25

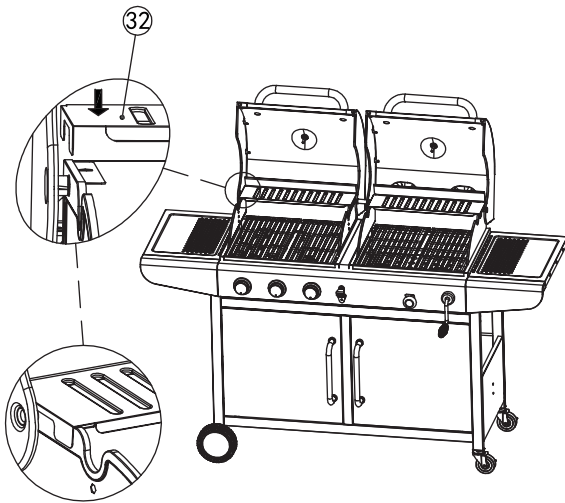

Attach the warming racks (32) between the lids and the fireboxes.

Step 26

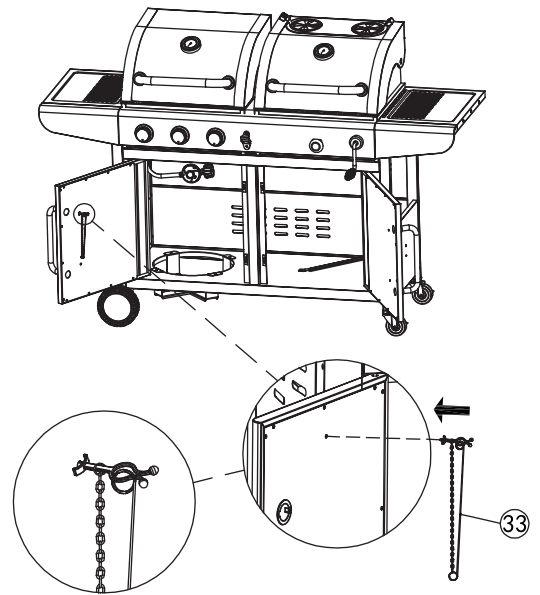

Install ignition match to the hole on the inner side of the left door.

Step 27

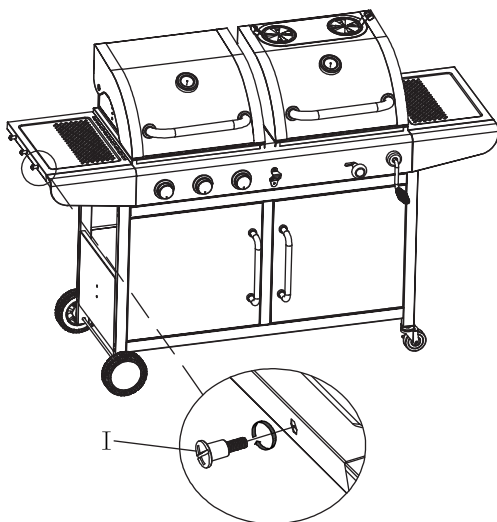

Screw 3 bolts (I) to the left side table.

Step 28

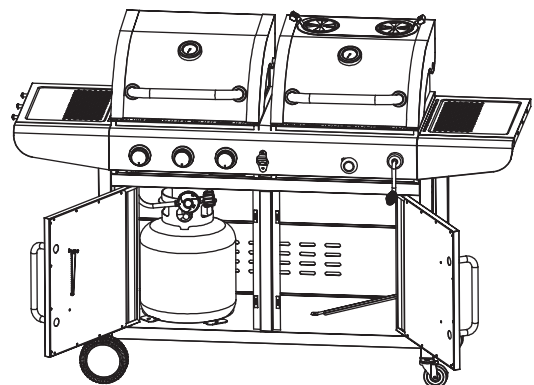

Fully assembled.

Your new grill has been designed and manufactured to high quality standards. It will provide you with many years of fun grilling time, however, it requires a minimal amount of maintenance. Please keep in mind the following FOR YOUR SAFETY.

### Operation

1. Your grill requires reasonable care during operation. It will be hot during cooking and cleaning.  
Never leave the grill unattended or move the grill when in use.
2. Children should never use your grill. Keep children and pets away when in use,
3. Only use your grill outside in a well-ventilated area. Never use indoors which includes any building, garage, shed, or under any type of flammable canopy or overhang.
4. Ensure your grill is on level ground and the locking casters are locked before use.
5. Turn all gas valves off if the burners flame out while cooking.
6. Turn off the burners and shut off the LP tank in case of a grease fire.
7. Keep the grilling area clear and free from combustible materials, gasoline, and other flammable vapors and liquids.
8. Keep the ventilation openings of the tank enclosure free and clear from debris.
9. Do not lean over the griddle or touch the edges of the firebox, air vent, or lid when in use.
10. Do not obstruct the flow of air for combustion and ventilation.
11. Do not use charcoal briquettes, lava rock, or any type of ceramic product in the gas section of this grill.
12. Do not install or use in a reconstructive vehicle or boat.

### LP Gas and Cylinder Information

Your new grill operates on LP (Liquified Petroleum) Gas. It is odorless, colorless, and non-toxic when produced. You can smell LP gas as it has been given an odor similar to rotten eggs for your safety.

Triangular Hand Wheel

Your grill uses the newest and safest LP gas cylinder (tank) which includes two features:

1. An OPD (Overfill Protection Device) – prevents accidental gas leaks caused by overfilling of the tank. Each tank contains a float that closes the input valve when the tank is 80% full. This allows room for the propane gas to expand in hot temperatures. A triangular hand wheel distinguishes this type of tank.
2. An OCC1 Type1 Quick Connect Valve that provides fast tank hook-ups and requires only to be tightened by hand.

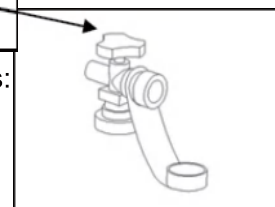

### TRANSPORTATION AND STORAGE

1. The propane tank must include a collar to protect the gas supply valve.
2. Do not store a spare propane tank under or near the grill.
3. Never fill the propane tank beyond 80% capacity.
4. If the warnings in 2 and 3 above are not heeded exactly, a fire causing death or serious injury may occur.
5. Always transport in an upright position.
6. Do not smoke while transporting your propane tank.
7. Place a dust cap on the tank gas valve outlet whenever the tank is not in use. Use only the type of dust cap that is provided with the tank valve when purchased. Other types of cap or plugs may result in leakage of propane.

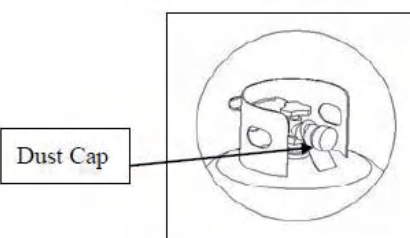

## **CYLINDER SPECIFICATIONS:**

Tank purchased or exchanged for your gas grill must be manufactured and marked in accordance with the specifications for LP Gas cylinder of the U.S. Department of Transportation (DOT) or the National Standard of Canada, CAN/CSA –B339, Cylinders, Spheres and Tubes for Transportation of Dangerous Goods and Commission., be equipped with a listed over-filling prevention device (OPD), and be equipped with a cylinder connection device compatible with connection for outdoor cooking appliances.

### **The cylinder must also be equipped with:**

1. A shut-off valve terminating in a Type 1 gas cylinder valve outlet
2. A Type 1 valve that prevents gas flow until a positive seal is made
3. A collar to protect the cylinder shut-off valve
4. A safety relief device that is directly linked with the vapor space of the cylinder

### **WARNING**

**A frosty cylinder valve indicates possible gas overfill. Close the LP valve and call your LP dealer immediately.**

## **LP GAS CYLINDER (NOT SUPPLIED WITH THIS GRILL)**

1. The LP (Liquid Propane) gas tank specifically designed to be used with this grill must have a 20 lb. (9.1 kg) capacity incorporating a Type 1-cylinder valve and an over-filling protection device (OPD).
2. This grill is designed to fit Worthington, Manchester, or SMPC brand 20 lb. (9.1 kg) cylinders. Other brands may fit this grill if the top collar and bottom support ring have similar dimensions.
3. DO NOT connect this grill to an existing #510 POL cylinder valve with left-hand threads.  
The Type 1 valve can be identified by the large external threads on the valve outlet.
4. DO NOT connect to a propane cylinder exceeding this capacity.
5. DO NOT connect to a cylinder that uses any other type of valve connection device.

## LP CYLINDER LEAK TEST

A leak test should be conducted each time a propane tank is refilled or exchanged. Do not smoke or use any type of flammable material in the area during this leak test. Do not use an open flame to check for leaks.

1. Test outside in a well-ventilated area.
2. Use a paintbrush and a solution of liquid dish detergent and water as needed. Do not use cleaning products because they can damage the fuel supply parts.
3. Brush the soapy solution onto the areas indicated by the arrows in the right side diagram.
4. Growing of bubbles indicates gas leakage.

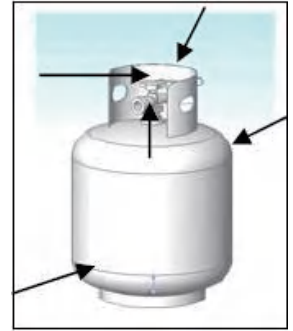

## Regulator and LP Cylinder Connections

### CAUTION

Only use the gas pressure regulator provided with this outdoor cooking appliance. This regulator is set for an outlet pressure of 11 inches water column.

Your regulator is equipped with a QQC Type 1 quick connection system. It will not allow gas to flow until a positive seal has been made. It has a thermal element that will shut off the gas flow if the temperature reaches 115 °C (240 °F). It also has a flow-limiting device that will restrict the flow of gas to 0.28 cubic meters per hour (10 cubic feet per hour). Before each use, check the gas hose for excessive abrasion, wear, or cuts. Replace a damaged hose assembly with the one specified in the parts list before using the grill.

## CONNECTING THE CYLINDER TO THE REGULATOR AND HOSE

1. Be sure the LP tank is OFF by turning the hand wheel clockwise until it stops.
2. Place the tank on the hook under the grill body with the valve facing outward. See Assembly instructions to secure the tank into the nesting hole located in the bottom shelf of the grill body.
3. Be sure all control knobs are turned to the OFF position.
4. Remove the safety cap from the cylinder valve.
5. Center the regulator nipple into the cylinder valve.
6. Turn the black nut clockwise until it stops. Hand tighten Only.

**Do not use a wrench.**

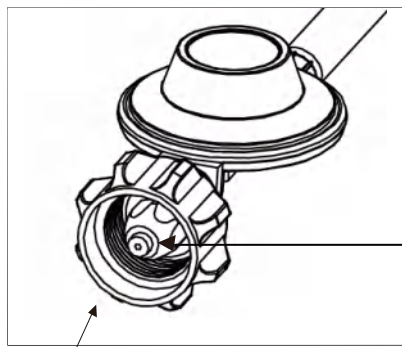

GCC 1 Type 1 Connector

The regulator must be connected to the cylinder valve in a straight line.

Center the regulator nipple into the cylinder valve.

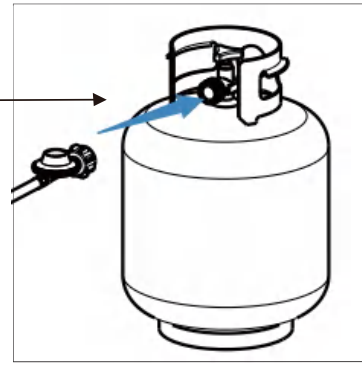

**⚠ WARNING**

Always keep the gas cylinder in the upright position at all times.

**WARNING**

1. Do not connect this grill to any unregulated sources of propane.
2. Before each use, check the gas hose for excessive abrasion, wear or cuts. Replace a damaged hose assembly with the one specified in the parts list before using the grill.
3. Always perform the Leak Test listed below before using your grill for the first time, if the cylinder has been changed, if any gas supply components have been changed, if the regulator flow-limiting device has been activated, or after a long period of non-use.
4. Do not attempt to connect this grill to the LP system of a motor home or trailer.

**LEAK TESTING THE REGULATOR, VALVES, HOSES, AND CONNECTIONS**

1. Ensure the LP cylinder valve and all burners are OFF.
2. Ensure the LP cylinder is connected to the regulator.
3. If the warnings 1 and 2 above are not strictly followed, there is risk of fire that may lead to serious injury or death.
4. Mix water and liquid dishwashing detergent as required. Do not use any household cleaner solution.
5. Open the LP tank valve by turning the hand wheel counterclockwise one turn. If you hear a rushing sound, turn the gas off immediately. In that case, there could be a leak at the connection. Reconnect the cylinder to the regulator.
6. Spray or brush on the dishwashing detergent solution covering the following areas: regulator and cylinder connection, gas hose connections to the regulator, all gas hoses, and all gas connections to the burner, including the side burner.
7. Bubbles that develop on any of the parts and connections listed above indicate a gas leak. Immediately shut off the LP tank valve by turning the valve clockwise. Retighten the connections or order replacement parts as needed. Continue to test as necessary until no leaks are detected.
8. Close the LP tank valve by turning the hand wheel clockwise.

**WARNING**

1. DO NOT USE THE GRILL if there are leaks. Be sure the LP cylinder valve is closed. If the LP cylinder is still leaking, contact your LP dealer or call 911.
2. Do not use any matches, open flames, or smoke during leak testing.
3. Do not light any burners during leak testing.
4. Replacement parts, including a replacement hose assembly, must be as per the specifications in the parts list.

**Failure to comply with these instructions may result in serious bodily injury.**

Each grill burner is tested and calibrated at the factory prior to shipment; however, variations in the local gas supply may make it necessary to adjust the burners. Please visually check the flames of the burners. Always visually inspect your grill before lighting. Replace any hose that is frayed or cracked. Look for anything that could block ventilation and remove such a blockage or move the grill. After lighting, check the flame pattern to ensure you have even heat distribution for each burner. If burners don't light up, or if the flame pattern is uneven, see the Troubleshooting section.

### **WARNING**

1. Read and follow the instructions before lighting.
2. If ignition does not occur in 5 seconds, turn the burner control(s) off, wait 5 minutes and repeat the lighting procedure.
3. Remove any fluid from the ash tray before lighting charcoal.
4. Consider using non-liquid charcoal starters.

### **LIGHTING THE MAIN BURNERS USING AUTOMATIC IGNITION**

1. Open the lid before lighting.
  2. Check that all control knobs are in the "OFF" position.
  3. Turn gas supply on at the gas tank valve or at the regulator.
  4. Push in the control knob and turn it anti-clockwise to the "H" position. Push and hold the ignitor button for 3 seconds until the burner lights.
  5. If the burner does not ignite, turn the control knob to the "OFF" position, wait for 5 minutes before attempting to relight the burner.
  6. If the burner ignites, repeat for the other burners.
- \* Should the burners still fail to ignite, check the gas supply and refer to the Troubleshooting section.

### **LIGHTING THE CHARCOAL GRILL**

1. Open the lid and the dampers.
  2. Remove the cooking grates and raise the charcoal pan to its highest setting by the crank handle.
  3. Stack max. 3 lb. of regular charcoal briquettes in a pyramid and saturate with lighter fluid.
- Warning: Do not use gasoline, kerosene, or alcohol for lighting. Use of any of these or similar products can cause an explosion possibly leading to severe bodily injury.
4. Light the charcoal briquettes in several places.
  5. After the briquettes produce a red glow or turn gray, spread them out across the charcoal pan. Please use a suitable fireproof tool with a long heat-resistant handle when you do this.
  6. Lower the charcoal pan to the lowest setting and put back the cooking grates.
  7. Adjust the cooking temperature by monitoring the height of the charcoal pan. Leave the lid open or closed based on the type of meat you cook.

### **MANUALLY LIGHTING THE BURNERS WITH THE IGNITION MATCH**

1. Open the lid.
2. Insert a match in the end of the match holder that is installed on the inside of the cabinet door.
3. Light the match.
4. Immediately place the lit match through the spaces in the grill gates near the ports of the burner between the flame tamers. Make sure the lit match is close to the burner ports.
5. Press in the control knob and turn it counter-clockwise to the "HI" position and the burner should light immediately.
6. Repeat 2~5 steps for the other burners.
7. Adjust burners to desired cooking settings.

### **TURNING OFF YOUR GRILL**

1. Turn off the gas supply at the propane tank by turning the valve clockwise to full stop.
2. Turn all control knobs to the OFF position.
3. Let the charcoal burn out completely after grilling.

## WARNING

1. Do not clean any part of your barbecue grill in a self-cleaning oven.
2. Do not use oven cleaners, abrasive kitchen cleaners, cleaners that contain citrus products, or mineral spirits.
3. Clean your grill regularly to prevent grease buildup, grease fires or excessive flare-ups.
4. Always allow the grill to cool down prior to cleaning.

**STAINLESS STEEL** Clean with multipurpose, low-abrasion, non-phosphorous metal or stainless steel polish and a soft cloth. Always polish in the direction of the finish. Do not allow grease and dirt to accumulate. In addition, several products and naturally occurring substances will damage all stainless-steel finishes.

These include, but are not limited to, swimming pool chemicals (chlorine and bromine), lawn and garden fertilizers, ice-melting products, sea or other salt water, urine, bird droppings and tree sap. Upon contact with these substances, immediately wash and dry the stainless-steel surface, being careful to avoid burns.

**OTHER EXTERIOR SURFACES** Wash with mild dishwashing detergent and warm water. A cloth, soft brush (non-metallic), or plastic cleaning pad can be used. Rinse thoroughly and wipe dry.

**COOKING GRATES AND HEAT DIFFUSERS** Use a stiff brass brush. Wash with warm water and mild dishwashing detergent, rinse and dry.

**GREASE CUP** Check after each use. Remove and empty the grease cup when half full. It can be washed with warm water and mild dishwashing detergent.

**BURNERS** We recommend you clean your burners at least twice a year, or before use, if the grill has not been used in over one month.

**CHARCOAL PAN AND ASH TRAY** After the charcoals burn out completely after grilling, clean the ash dropping from the perforated charcoal pan to the ash tray. Pull out the ash tray and empty out the cold ash and grease.

## WARNING

Small insects and spiders may enter the burner tubes. Sometimes they will build nests or spin webs that can block or reduce the amount of gas flowing through the burner. You will usually see a smaller flame, or a flame that is mostly yellow rather than blue coming from the burner when this happens. Other signs include uneven or low heat, or difficulty igniting the burners. In cases of severe blockage, this may cause the flame to burn backwards, and outside of the burner tubes, which can cause damage to your grill and/or personal injury. **IMMEDIATELY SHUT OFF THE FLOW OF PROPANE GAS AT THE TANK BY TURNING THE HAND WHEEL CLOCKWISE TO FULL STOP SHOULD THIS HAPPEN.** Wait for the grill to cool down and then clean all burners.

## CLEANING THE BURNERS

1. Ensure the gas is turned off at the propane tank.
2. Remove the cooking grates, flame tamers.
3. Lift each burner up and out.
4. Clean the inside of the burner using a stiff wire. A straightened coat hanger will work.  
An alternative is to use compressed air. Always wear protective gear for your eyes when using this method.  
**Never enlarge the burner ports during cleaning.**
5. Brush the outer surface of the burner.
6. Ensure all ports (holes) are free of debris.
7. Inspect the burners. Replace any that have cracks or enlarged ports.
8. Replace flame tamers and cooking grates.
9. Perform a Leak Test described earlier in this Owner's Manual.

### WARNING

Proper placement of the burner and valve is vital to ensure safety.

## BURNER FLAMES

Always check the burner flame patterns after lighting. A good flame should be primarily blue with a yellow tip and have a minimal amount of flicker. Some yellow tips are OK if they are smaller than 2.5 cm (1"). New burners sometimes have oil residue, which will cause yellow flame when burning off. Variations in gas supply, altitude, weather, and other factors can all impact burner performance. Older grills can also show more yellow flame due to food deposit, oil, and fat buildup.

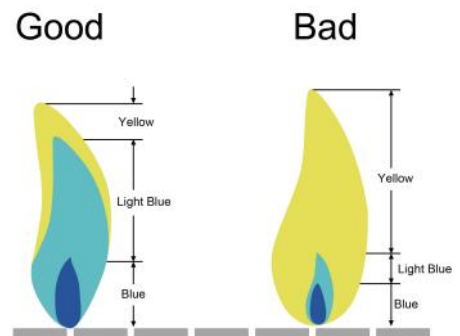

## ALWAYS

1. Keep the grilling area clear and free from combustible materials, gasoline and other flammable vapors and liquids.
2. Do not obstruct the air flow for combustion and ventilation.
3. Keep the ventilation openings of the cylinder enclosure free and clear from debris.

## GRILL STORAGE

1. Clean your grill before storage.
2. Storage of a gas grill indoors is permissible only if the propane tank is disconnected and removed from the gas grill.
3. Cover the grill.
4. Perform a Leak Test before using the grill after it has been kept in storage for some time.

Emergencies	Possible cause	Prevention/ Solution
Gas leaking from cracked/cut/ burned hose	Damaged hose	Turn off gas at LP tank, if hose is cut or cracked, replace hose. Conduct LP tank leak test and check regulator connection to the LP tank.
Gas leaking from LP tank	Mechanical failure due to aging or mishandling	Turn off LP tank valve.
Gas leaking from LP tank valve	Failure of tank valve due to mishandling or mechanical failure	Turn off LP tank valve. Return LP tank to gas supplier.
Gas leaking between LP tank and regulator connection	Improper installation, loose connection, failure of rubber seal	Turn off LP tank valve, remove regulator from cylinder and visually inspect the rubber seal for damage. Conduct LP tank leak test and check regulator connection to the LP tank.
Fire coming through control panel	Fire in burner tube section of the burner due to partial blockage	Turn off control knobs and LP tank valve. After the fire is out and grill is cold, remove the burner and inspect for spider nests or rust. See natural hazards and cleaning the burner assembly pages.

Troubleshooting: Problem	Possible cause	Prevention/ Solution
Grease fire or continuous excessive flame above cooking surface	Too much grease buildup in burner area	Turn off LP tank. Leave lid open to allow the flames to die down. After cooling, clean food particles and excess grease from inside the firebox area, grease cup/pan/tray, and other surfaces.
Burner will not light when using the ignitor	Gas issues 1. Trying to light wrong burner 2. Burner not engaged with control valve 3. Obstruction in burner 4. No gas flow 5. Vapor lock at coupling nut to LP tank 6. Coupling nut and LP tank valve not fully connected	1. See instructions on control panel and the use and care section. 2. Make sure valve are positioned inside the burner tubes. 3. Ensure burner tubes are not obstructed with spider webs or other material; see cleaning section in use and care. 4. Make sure LP tank is not empty. If LP tank is not empty, check "sudden drop in gas flow." 5. Turn off knobs and disconnect coupling nut from LP tank. Reconnect and retry. 6. Turn the coupling nut approximately one-half to three-quarters.
Burner will not light using the ignitor	Electrical issues: 1. Electrode cracked or broken; sparks at crack 2. Electrode tip not in proper position 3. Wire and/or electrode covered with cooking residue 4. Wires are loose or disconnected 5. Wires are shorting (sparking) between ignitor and electrode. 6. Push button sticks at bottom sparking between ignitor and electrode.	1. Replace electrode. 2. Tip of electrode should be pointing toward the port hole in the burner. The distance should be 1/8" to 3/16". Adjust if necessary. 3. Clean wire and or electrode with rubbing alcohol and clean swab. 4. Reconnect wires or replace electrode/wire assembly. 5. Replace ignitor wire. 6. Replace ignitor. 7. Inspect wire insulation and proper connection. Replace wires if insulation is broken.

Troubleshooting: Problem	Possible cause	Prevention/ Solution
Burner will not light with matchstick	1. See “gas issues” on previous page. 2. Improper method of lighting using a matchstick	1. See “Pilot Gas Control Ignition” section in use and care.
Sudden drop in gas flow or low flame	1. Grease buildup 2. Excessive fat in meat 3. Excessive cooking temperature	1. Clean burners and inside of grill/ firebox. 2. Trim fat from meat before grilling.
Flame blows out	High or gusting winds/Low Lp gas/Excess flow valve tripped	Turn front of grill to face wind or increase flame height. Refill LP tank. Refer to “sudden drop in gas flow” above.
Persistent grease fire	Grease trapped by food buildup around the burner system	Turn knobs to OFF. Turn gas off at the LP tank. Leave lid in position and let the fire burn out.After the grill cools, remove and clean all parts.
Flashback... (fire in burner tube(s))	Burner and burner tubes are blocked.	Turn knobs to OFF. Clean burner and/or burner tubes. See burner cleaning section in use and care.
Flare-up	1. Grease buildup 2. Excessive fat in meat 3. Excessive cooking temperature	1. Clean burners and inside of grill/ firebox. 2. Trim fat from meat before grilling. 3. Adjust (lower) temperature.
Unable to fill LP tank	Some dealers have older fill nozzles with worn threads.	When turning worn nozzles, they don't have enough “bite” to engage the valve. Try a different LP dealer.
One burner does not light from other burner(s)	Grease buildup or food particles in end of carryover tube	Clean carry-over tube with wire brush.

**If your problem is not resolved using the troubleshooting information above, please contact your local gas dealer.**

**PREHEATING:** The grill lid should be closed while preheating the grill. It is necessary to preheat the grill before cooking certain foods, depending on the type of food and the cooking temperature.

For food that requires a high cooking temperature, the grill should be preheated for five minutes; for food that requires a lower cooking temperature, the grill should be preheated for two to three minutes.

Cooking with indirect heat: You can cook poultry and large cuts of meat slowly to perfection on one side of the grill by the indirect heat from the burner on the other side. Heat from the lighted burner circulates gently throughout the grill, thereby cooking the meat or poultry without any direct flame touching it. This method greatly reduces risk of flare-ups when cooking extra fatty cuts as there is no direct flame to burn the fat and juices that drip down while cooking.

**CAUTION:** If the burners go out during use, close the gas supply at source, and turn off all gas valves. Open the lid and wait five minutes before attempting to re-light (this allows accumulated gas fumes to clear).

**CAUTION:** In case of a grease fire, close the gas supply at source, turn off all burners and leave the lid closed until the fire is out.

**CAUTION:** DO NOT attempt to disconnect any gas fitting while the grill is being used. As with all appliances, proper care and maintenance will ensure your grill is in top operating condition and will prolong its life.

**CAUTION:** The side burner lid will get hot if it is used when the lid is closed.

## Direct Heat

<b>BEEF INTERNAL TEMPERATURE CHART</b>			
<b>Cooking Degree</b>	<b>Internal Core Temperature</b>	<b>Internal Description</b>	<b>Firmness</b>
Rare	125 °F	Center is bright red, pinkish toward the outer portion, and warm throughout	Soft to the touch
Medium Rare	130-135 °F	Center is very pink, slightly brown toward the outer portion and slightly hot	Yields only slightly to the touch
Medium	140-145 °F	Center is light pink, outer portion is brown and hot throughout	Beginning to firm to the touch
Medium Well	150-155 °F	Mostly brownish gray throughout with a hint of pink in the center	Firm to the touch
Well Done	155 °F and above	Steak is brownish gray throughout	Firm or hard to the touch
<b>POULTRY INTERNAL TEMPERATURE CHART</b>			
Whole Chicken	165 °F	Cook until the juices run clear	Firm to the touch
Dark Meat	165 °F	Cook until white throughout but still moist	Firm to the touch
Breast Meat	165 °F	Cook until white throughout but still moist	Firm to the touch
Thigh, Wings and Legs	165 °F	Mostly brownish gray throughout with a hint of pink in the center	Firm to the touch
<b>PORK INTERNAL TEMPERATURE CHART</b>			
Medium	150 °F	Pink in the center	
Well Done	160 °F and above	Pork is uniformly white/brown throughout	
Pork Ribs	180-200 °F	Pale white. Cook medium to well done	
Raw Sausage	160 °F	No longer pink	
Sausage (Pre-cooked)	140 °F	No longer pink	

---

## STEAK (& ALL MEATS):

- Cook food on the charcoal side of the unit, directly above coals/heat.
- To grill meats, raise fire grate to high position (hot) and sear for one minute on each side with the lid open to seal in flavor and juices.
- Then lower the fire grate to the medium position with lid closed and cook to desired degree.
- Control heat with dual dampers and adjustable fire grate.

### Tip:

Place grilled meat back in the marinade for several minutes before serving - it will be tastier and juicier.

### CAUTION:

Boil extra marinade first to kill bacteria remaining from the raw meat.

---

## MARINATED FLANK STEAK:

- Mix marinade ingredients in a nonmetal dish.
  - Let steak stand in marinade for no less than 4 hours in the refrigerator.
  - Brown each side for 5 minutes, but center should remain rare.
  - Cut steak diagonally across the grain into thin slices before serving.
  - Grill with fire grate in high(hot) position with lid open or closed.
- 

## Meat Marinade

- 1/2 cup vegetable or olive oil
  - 1/3 cup soy sauce
  - 1/4 cup red wine vinegar
  - 2 tbsp lemon juice
  - 1 tsp dry mustard
  - 1 minced clove garlic
  - 1 small minced onion
  - 1/4 tsp pepper
- 

## QUAIL OR DOVES:

- Cover the birds with good amount of seasoning and marinate overnight.
  - Pour remaining dressing and cover with Texas Pete Hot Sauce for 6 hours.
  - Wrap birds in thick bacon secured by a toothpick.
  - Place on grill. Keep turning until bacon is black.
  - Grill for 20 minutes. Sear with lid open and fire grate in high (hot) position for 1 minute on each side before lowering the grate and closing the lid.
  - To smoke the birds, place them in the center of the grates with fire in both ends of the fire box.
- 

## HOT DOGS:

- Grill with lid up and cooking grates in high (hot) position for approximately 6 minutes.
  - Turn every few minutes.
- 

## SWEET CORN IN HUSKS:

- Trim excess silk from end and soak in cold salted water 1 hour before grilling.
  - Grill 25 minutes – turning several times.
- 

---

## KABOBS:

- Alternate any combination of meat, onions, tomatoes, green peppers, mushrooms, zucchini, circular slice of corn-on-the-cob, or pineapple on skewers. Meat could consist of shrimp, scallops, lobster, chicken, sausage, pork, beef, etc.
  - Marinate the meat in refrigerator for several hours.
  - Grill each side approximately 7 minutes, turning occasionally while basting with marinade.
  - Leave a small amount of room between pieces in order to cook faster.
  - Grill with lid up and the cooking grates in the lowest position.
- 

## Kabob Marinade:

- 1 cup soy sauce
- 1/2 cup brown sugar
- 1/2 cup vinegar
- 1/2 cup pineapple juice
- 2 tsp salt
- 1/2 tsp garlic powder

- Mix all ingredients in a saucepan and bring to boil.
  - Allow marinade to cool before marinating your meat in it.
  - Marinate beef in the mixture a minimum of 4 hours.
- 

## HAMBURGERS:

See meat marinade on prior pages.

- You may also marinate by allowing to stand in marinade for 1 or 2 hours at room temperature before cooking or let it stand in a covered dish in the refrigerator for up to 24 hours.
- Bring to room temperature before cooking.
  - Mix in chopped onions, green peppers, salt, sear 3/4 inch patties on each side, with cooking grates in high position for a few minutes.
  - Lower fire grate to medium position and grill with lid down to avoid flare-ups.
  - Cook each side 3 to 7 minutes according to desired degree.
  - Cook ground meat to 150 °F internal temperature or until juice runs clear (free of blood) to prevent E-coli infections.
  - Burgers can be basted with marinade when turning and/or other ingredients can be mixed in with the ground beef such as chili sauce or powder.
- 

## SHRIMP (Peeled) & CRAYFISH:

- Place on skewers.
  - Coat with melted butter and garlic salt.
  - Grill 4 minutes on each side or until pink. Cocktail sauce optional.
- 

## BAKED POTATOES:

- Rub with butter and wrap in foil and cook on grill with lid down for 50 minutes.
  - Turn after 25 minutes (no need to turn if smoked).
  - Squeeze to check if it is cooked.
-

Thanks for purchasing this Royal Gourmet® Grill Combo.

Royal Gourmet warrants its products to be free from defects in materials and workmanship under proper assembly, normal residential use and recommended care for **1-Year Full Warranty** from the date of original retail purchase. The warranty does not cover paint finish as it may burn off during normal use. **RUST is not considered a manufacturing or materials defect.**

For **5 Years** from the date of purchase, **any stainless steel burner** that rusts through will be replaced **free** of charge.

Within the stated warranty period, Royal Gourmet, at its discretion, shall replace defective components free of charge, with the owner being responsible for shipping. Royal Gourmet reserves the right to require that defective parts be returned, postage and or freight pre-paid by the consumer for review and examination. In the event of parts availability issues, Royal Gourmet reserves the right to substitute like or similar parts that are equally functional. Upon the expiration of such warranty, all such liability shall terminate.

**Note:** A dated sales receipt along with Model Number and Serial Number will be required for the warranty service.

The limited warranty will not reimburse you for the cost of any inconvenience, food, personal injury or property damage. All warranty coverage is void if this grill is ever used for commercial or rental purposes. And this limited warranty applies to the functionality of the product ONLY and does not cover cosmetic issues such as scratches, dents, corrosions or discoloring by heat, abrasive and chemical cleaners or any tools used in the assembly or installation of the appliance, surface rust, or the discoloration of stainless steel surfaces.

### ITEMS NOT COVERED IN THE WARRANTY SERVICE

Any failures or operating difficulties due to accident, abuse, misuse, alteration, misapplication, vandalism, improper installation or improper maintenance or service, or failure to perform normal and routine maintenance, including but not limited to damage caused by insects within the burner tubes, as set out in the owner's manual.

Deterioration or damage due to severe weather conditions such as hail, hurricanes, earthquakes or tornadoes, discoloration due to exposure to chemicals either directly or in the atmosphere.

Cost of service calls to your home.

Costs of removal or re-installation.

Pickup and delivery of your product.

Shipping or transportation costs.

Labor costs for installation and repair.

Liability for indirect, or consequential damages.

This limited warranty is the sole warranty given by Royal Gourmet and is in lieu of all other warranties, expressed or implied including implied warranty, merchantability, or fitness for a particular purpose. Neither Royal Gourmet nor the retail establishment selling this product has authority to make any warranties or to promise any remedies in addition to or inconsistent with those stated above.

Royal Gourmet's **maximum liability**, in any event, shall not exceed the purchase price of the product paid by the original consumer purchaser. Some states do not allow the exclusion or limitation of incidental or consequential damages. In such a case, the above limitations or exclusions may not be applicable.

**Do not return parts without prior to obtaining return authorization from our customer service department.**

Please do not hesitate to contact our customer service when you have any questions regarding assembly, warranty, or accessories. We will be happy to offer any replacement parts you need during the warranty period.



1-800-618-6798



service@royalgourmetusa.com



Mon - Fri, 8:30 AM- 5:30 PM, EST