

ASSEMBLY INSTRUCTIONS

IMPORTANT NOTE

**PLACE ALL PARTS ON CLEAN AND SMOOTH SURFACE SUCH AS A RUG OR CARPET TO AVOID THE PARTS FROM BEING SCRATCHED

**BEFORE YOU BEGIN, KINDY FOLLOW THE ASSEMBLY INSTRUCTIONS STEP BY STEP











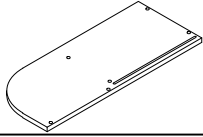

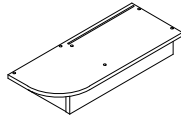
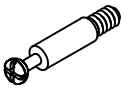
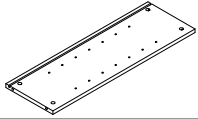
**DO NOT TIGHTEN ALL SCREWS AND BOLTS UNTIL THE CASES IS FULLY SET-UP

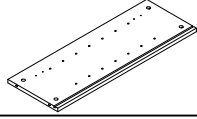

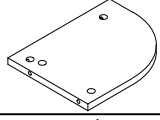
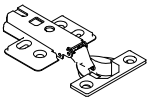
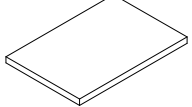
PLEASE DO NOT RETURN PRODUCT TO THE STORE

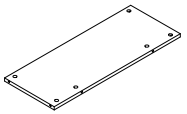
ASSEMBLY INSTRUCTIONS

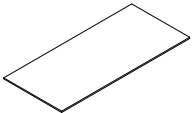
CARTONS ONLY ONE/HARDWARE LISTS

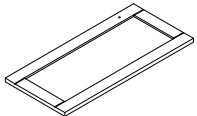
PART LISTS				HARDWARE LISTS			
NO	DESCRIPTION	SKETCH	Q'TY	NO	DESCRIPTION	SKETCH	Q'TY
1	Top Panel		1 PC	A	Cam lock		22 PCS
2	Bottom Panel		1 PC	B	Cam bolt		22 PCS
3	Left Side Panel		1 PC	C	Sticker Ø22		22 PCS
4	Right Side Panel		1 PC	D	Shelf support pin		8 PCS
5	Center Panel		2 PCS	E	Door hinge		2 PCS
6	Shelf		2 PCS	F	Bolt 5/32x22mm		1 PCS
7	Left/ Back Panel		1 PC	G	Handle		1 PCS
8	Right/ Back Panel		1 PC	H	Screws 3.5x14mm		12 PCS
9	Door		1 PC				

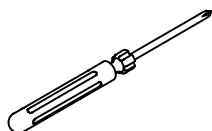

**Philips head screwdriver required for assembly
(not included)**

ASSEMBLY INSTRUCTIONS

HOW TO



Cam lock

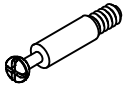

Cam bolt

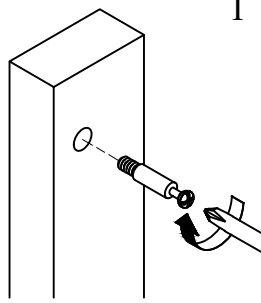

1. Screw Cam Bolt into panel until plastic sleeve is touching wood.

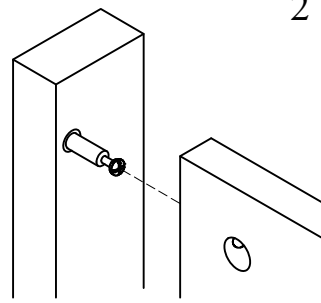

2. Insert Cam Bolt into bolt hole of joining panel.

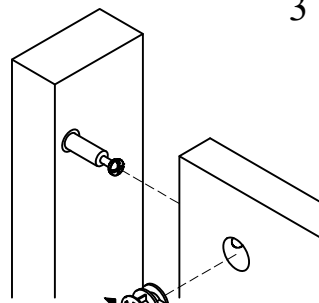

3. Insert Cam Lock with arrow facing bolt.

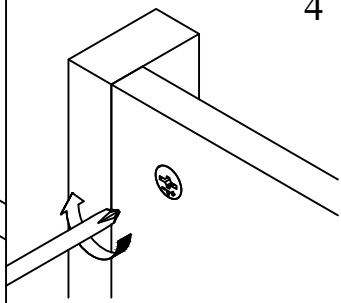

4. Gently turn Cam Lock 180° clockwise to lock into position.

Step 1:



Ⓐ x 4pcs

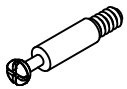

Ⓑ x 4pcs



Ⓒ x 4pcs

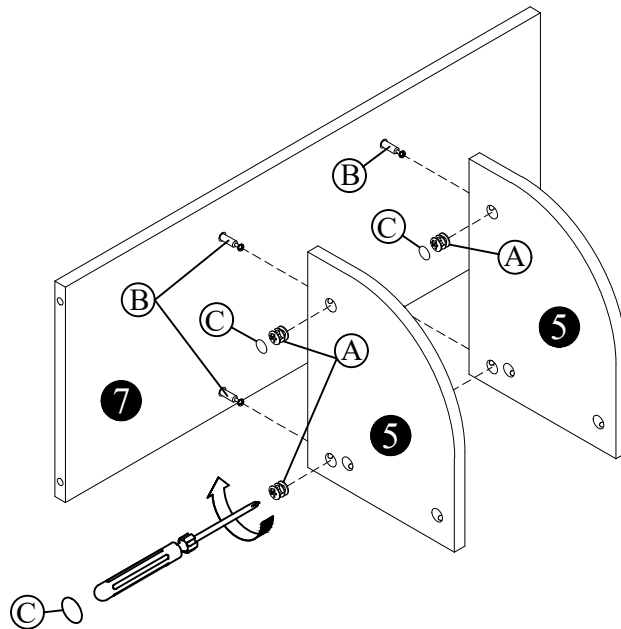

Step 2:



Ⓐ x 6pcs

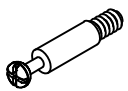

Ⓑ x 6pcs



Ⓒ x 6pcs

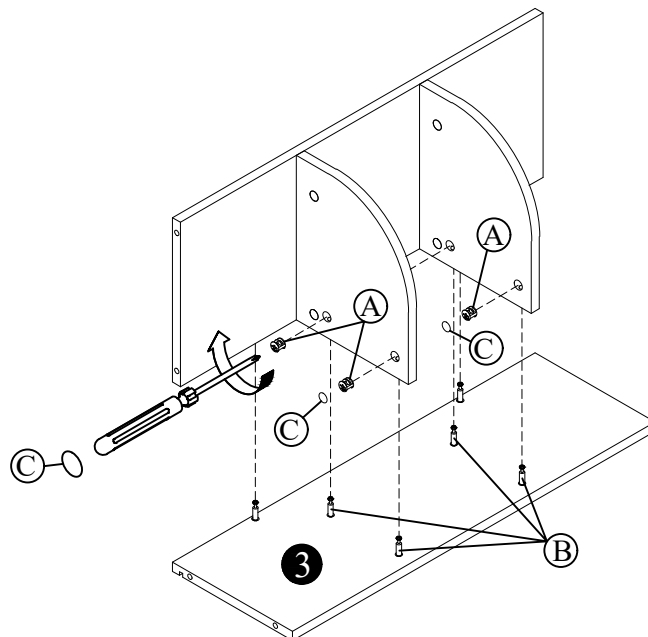

ASSEMBLY INSTRUCTIONS

Step 3:



Ⓐ x 4pcs

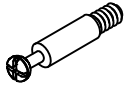

Ⓑ x 4pcs



Ⓒ x 4pcs

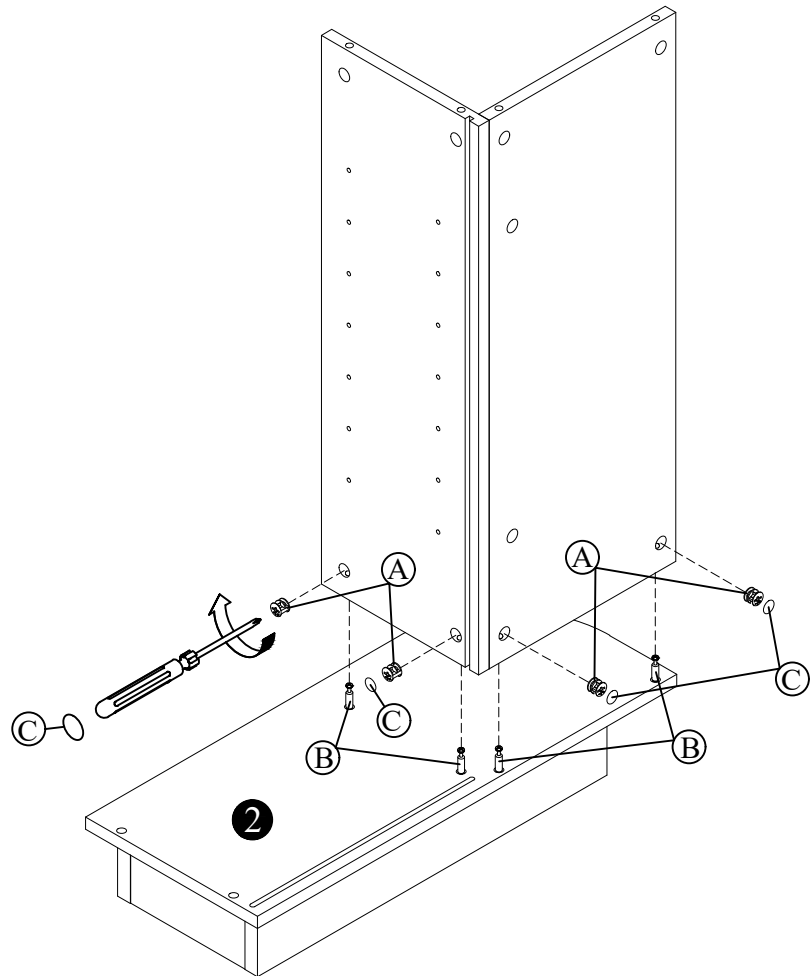

Step 4:



Ⓐ x 2pcs

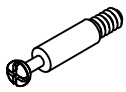

Ⓑ x 2pcs



Ⓒ x 2pcs

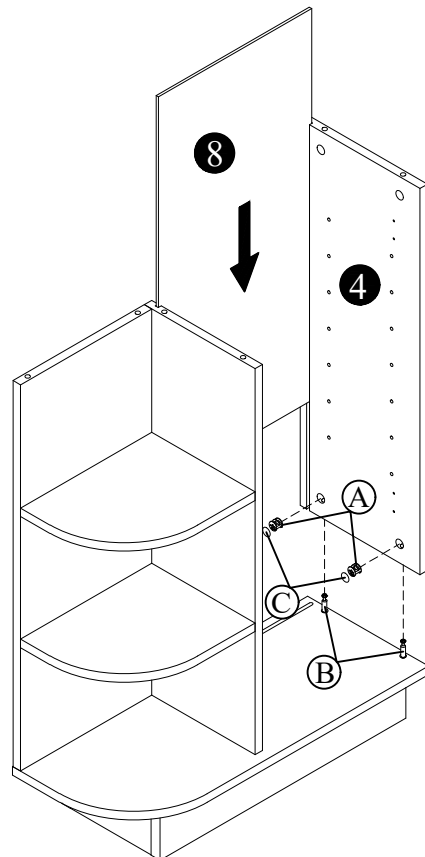

ASSEMBLY INSTRUCTIONS

Step 5:

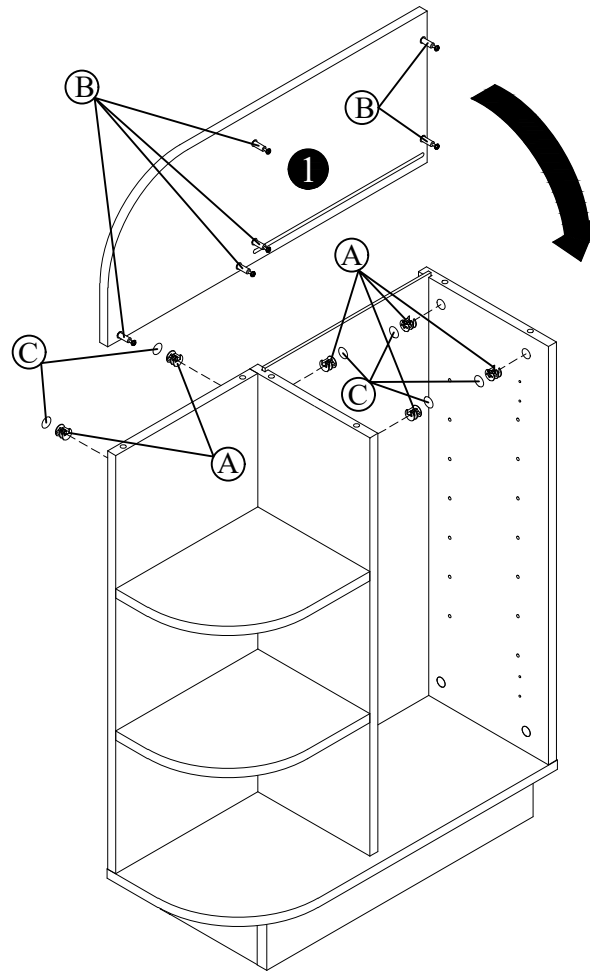
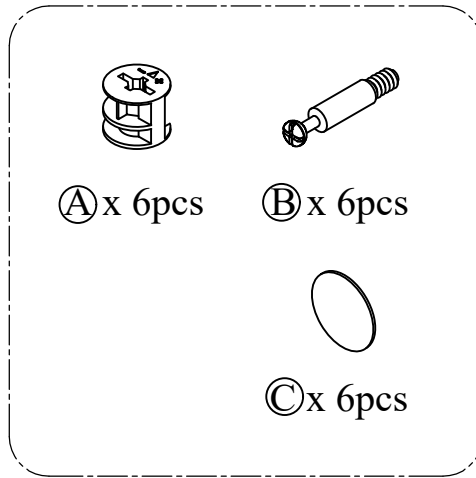

Step 6:

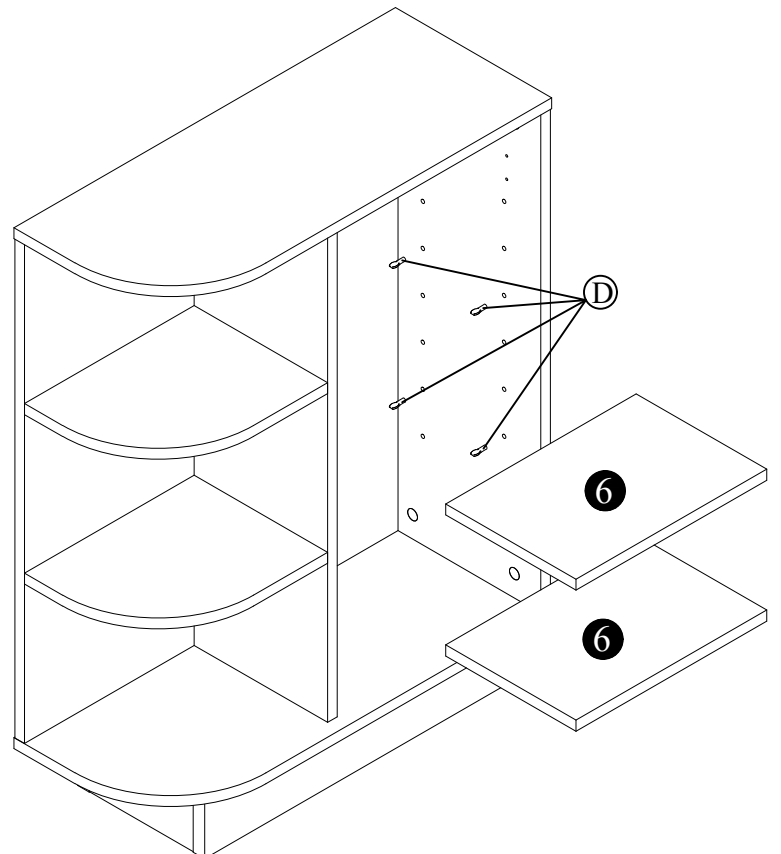
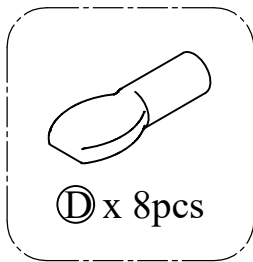

ASSEMBLY INSTRUCTIONS

Step 7:

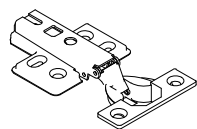

Ⓔ x 2pcs



Ⓕ x 1pcs

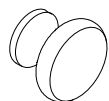

Ⓖ x 1pcs



Ⓖ x 12pcs

