

ASSEMBLY INSTRUCTIONS

SKU CODE:(N736P417831-N736P417832)

INSTRUCTIONS DE MONTAGE

SKU CODE:(N736P417831-N736P417832)

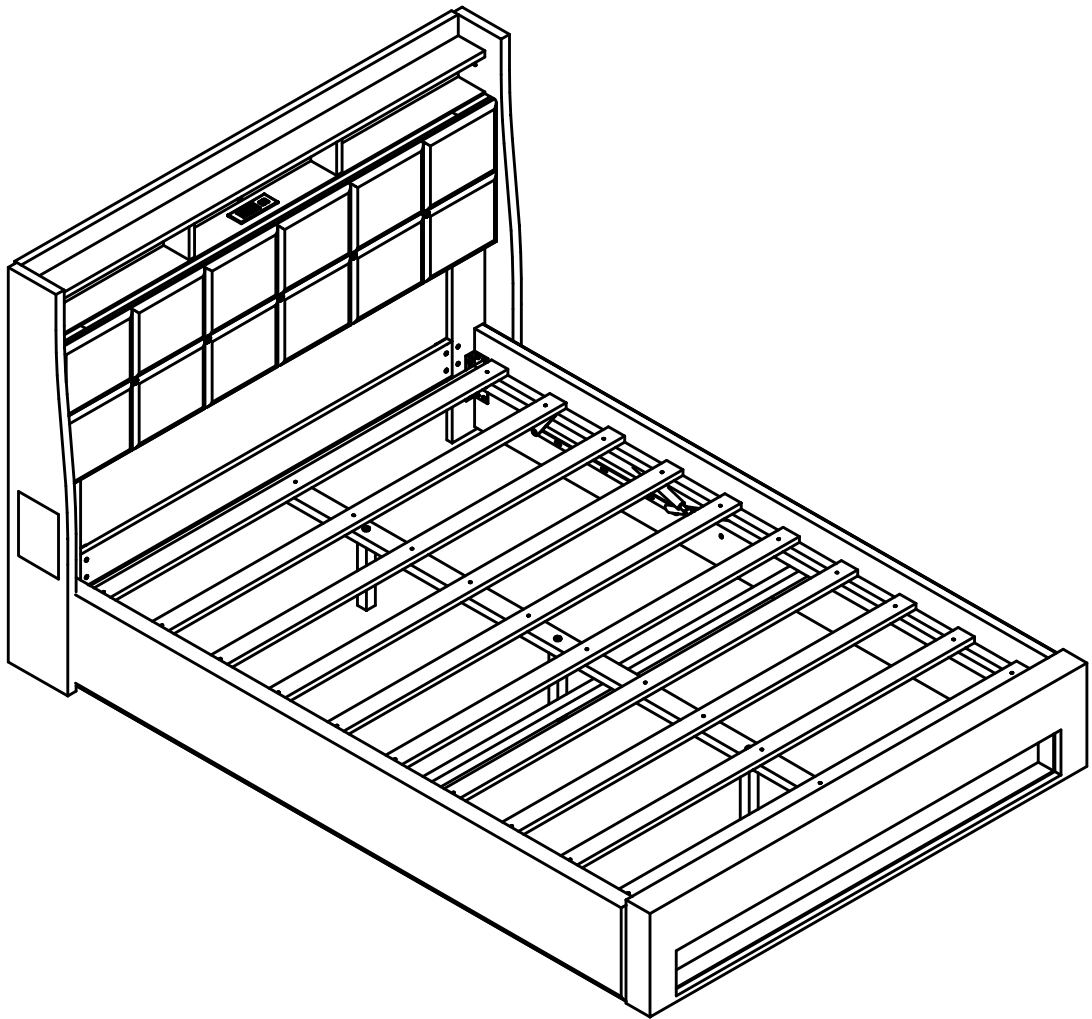



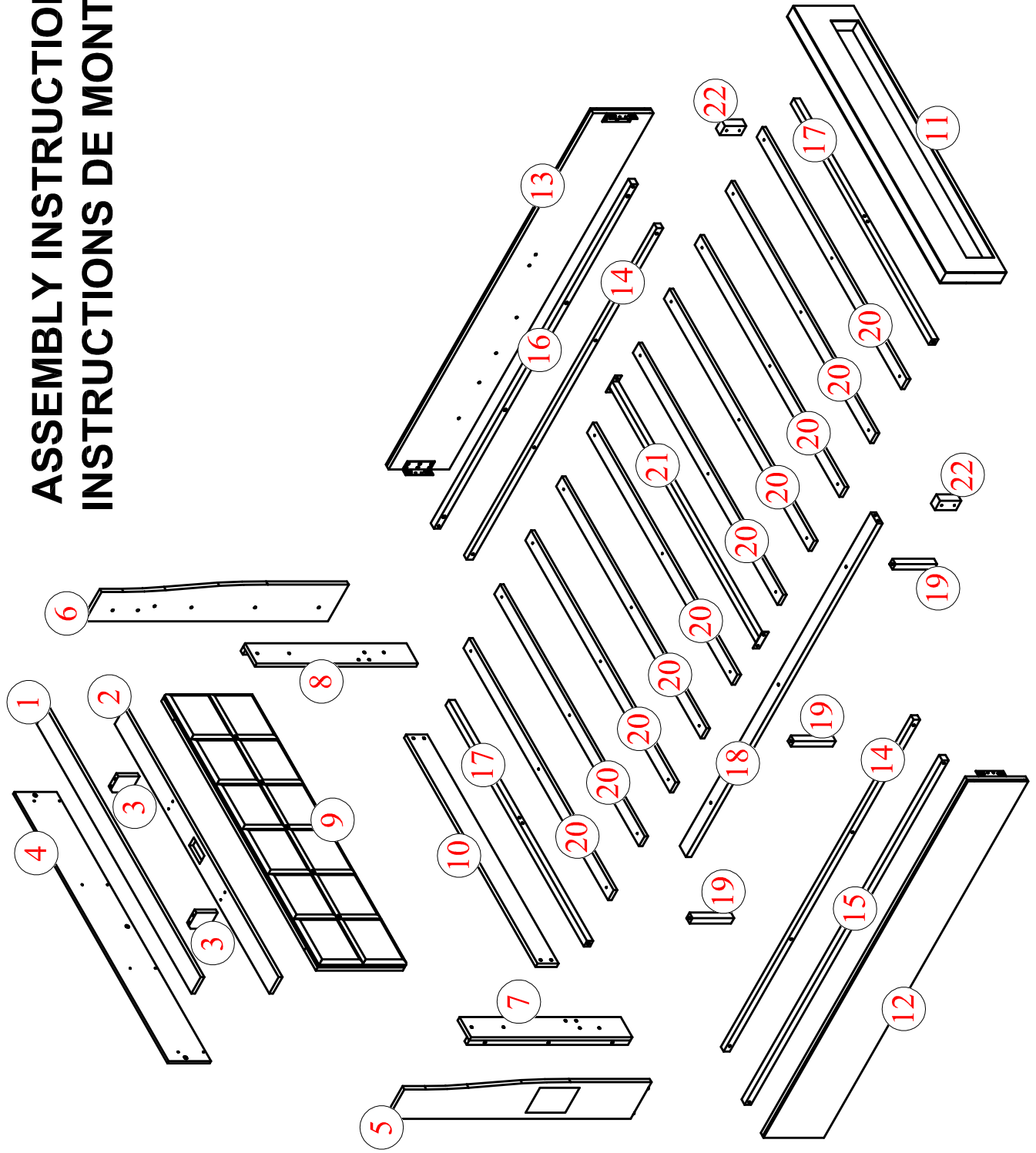



ASSEMBLY INSTRUCTIONS INSTRUCTIONS DE MONTAGE

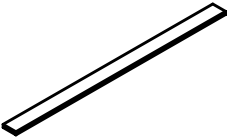
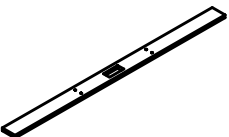

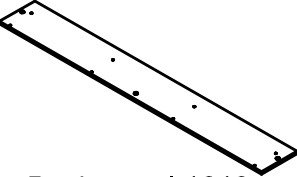
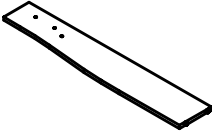
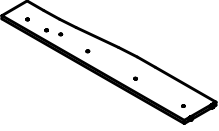
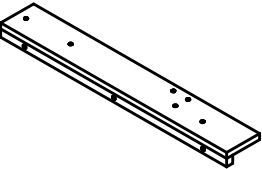
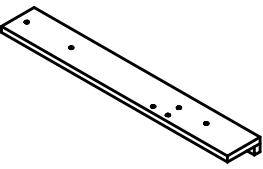
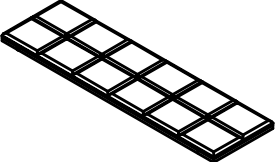
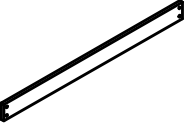
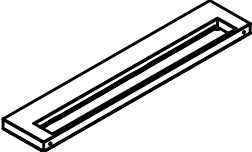
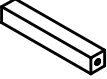
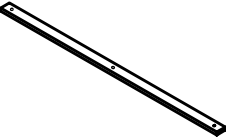

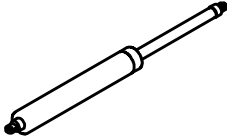
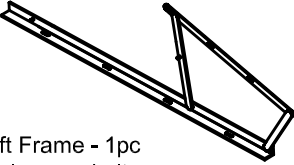
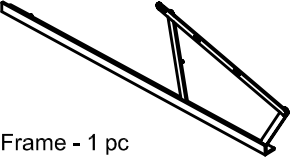
Part List (N736P417831)

Liste des pièces (N736P417831)

<p>1</p>  <p>Top rail 1620mm 1 pc Lisse supérieure 1620mm</p>	<p>2</p>  <p>Top rail 1620mm 1 pc Lisse supérieure 1620mm</p>	<p>3</p>  <p>Wooden bar 2 pcs Barre en bois</p>
<p>4</p>  <p>Back panel 1610mm 1 pc Panneau arrière 1610mm</p>	<p>5</p>  <p>Left side of the headboard 1 pc Côté gauche de la tête de lit</p>	<p>6</p>  <p>Right side of the headboard 1 pc Côté droit de la tête de lit</p>
<p>7</p>  <p>Left side of the headboard 1 pc Côté gauche de la tête de lit</p>	<p>8</p>  <p>Right side of the headboard 1 pc Côté droit de la tête de lit</p>	<p>9</p>  <p>Side mattress 1 pc Matelas latéral</p>
<p>10</p>  <p>Crossbar 1400mm 1 pc Barre transversale 1400mm</p>	<p>11</p>  <p>Footboard 1 pc Panneau de pieds</p>	<p>19</p>  <p>Legs Support 196mm 3 pcs Support de jambes 196mm</p>
<p>20</p>  <p>Slats 1525mm 10 pcs Lattes 1525 mm</p>	<p>22</p>  <p>Wooden bar 2 pcs Barre en bois</p>	<p>S</p>  <p>Piston 700N 2pcs Piston 700N</p>
<p>R</p>  <p>Right Lift Frame - 1pc Cadre de levage droit</p>	<p>T</p>  <p>Left Lift Frame - 1 pc Cadre relevable gauche</p>	<p>V</p>  <p>Black lining fabric 1 pc Tissu de doublure noire</p>
<p>D</p>  <p>USB Socket (1USB 1 Type-C) 1 pc Prise (1 USB 1 Type-C)</p>		



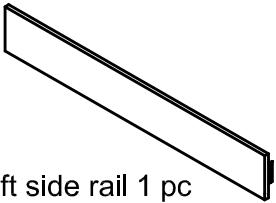
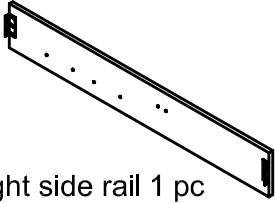
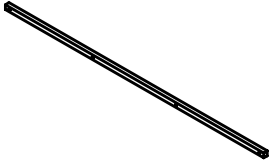
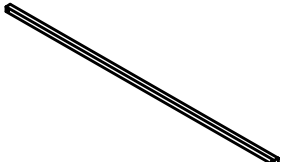
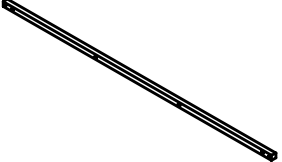

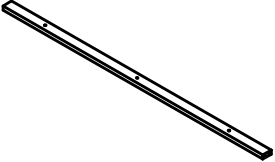
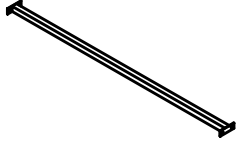











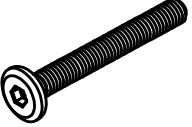

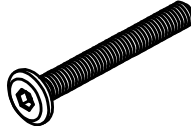

Part List (N736P417832)

Liste des pièces (N736P417832)

<p>12</p>  <p>Left side rail 1 pc Rail latéral gauche</p>	<p>13</p>  <p>Right side rail 1 pc Rail latéral droit</p>	<p>14</p>  <p>Support bar 1910mm 2 pcs Barre de support 1910mm</p>
<p>15</p>  <p>Left metal bar 1980mm 1 pc Barre métallique gauche 1980mm</p>	<p>16</p>  <p>Right metal bar 1980mm 1 pc Barre métallique droite 1980mm</p>	<p>17</p>  <p>Middle metal bar 1465mm 2 pcs Barre métallique centrale 1465mm</p>
<p>18</p>  <p>Slat support bar 1920mm 1 pc Barre de support de latte 1920mm</p>	<p>21</p>  <p>Middle metal bar 1551mm 1 pc Barre métallique centrale 1551mm</p>	

Hardware List (N736P417831)

Liste du matériel (N736P417831)

<p>A</p>  <p>1600mm LED Strip Light 1 pc Ruban LED de 1600 mm</p>	<p>B</p>  <p>Steel Bracket 40x40mm 10 pcs Support en acier 40x40mm</p>	<p>C</p>  <p>1/4" x 20 mm Hex-Head bolts 38 pcs Boulons à tête hexagonale 1/4" x 20 mm</p>
<p>E</p>  <p>M4 x 15 mm Wood Screws 2 pcs Vis à bois M4 x 15 mm</p>	<p>F</p>  <p>Ø8 x 30 mm Wood dowel 4 pcs Cheville en bois Ø8 x 30 mm</p>	<p>G</p>  <p>M4 x 40 mm Wood Screws 4 pcs Vis à bois M4 x 40 mm</p>
<p>H</p>  <p>1/4" x 40 mm Hex-Head bolts 21 pcs Boulons à tête hexagonale 1/4" x 40 mm</p>	<p>I</p>  <p>M4 x 50 mm Wood Screws 4 pcs Vis à bois M4 x 50 mm</p>	<p>J</p>  <p>Steel Bracket 100x80mm 2 pcs Support en acier 100x80mm</p>
<p>K</p>  <p>M4 x 25 mm Wood Screws 8 pcs Vis à bois M4 x 25 mm</p>	<p>L</p>  <p>Plastic Feet(Ø32x16) 2 pcs Pieds en plastique (Ø32x16)</p>	<p>M</p>  <p>1/4" x 60 mm Hex-Head bolts 4 pcs Boulons à tête hexagonale 1/4" x 60 mm</p>
<p>N</p>  <p>Ø11.5 x 15 mm Horizontal -Hole bolts 4 pcs Boulons à trou horizontal Ø11.5 x 15 mm</p>	<p>O</p>  <p>A B Fixed brace 2 set Attelle fixe 2 set</p>	<p>P</p>  <p>LED extension cord 3000mm 1 pc Rallonge LED 3000mm</p>
<p>Q</p>  <p>LED power cord 1200 mm 1 pc Câble d'alimentation LED 1200 mm</p>	<p>U</p>  <p>1/4" x 15 mm Hex-Head bolts 20 pcs Boulons à tête hexagonale 1/4" x 15 mm</p>	<p>W</p>  <p>M4 x 30 mm Wood Screws 38 pcs Vis à bois M4 x 30 mm</p>
<p>X</p>  <p>Allen Wrench 1pc Clé Allen</p>	<p>Y</p>  <p>Fabric strap 1 pc Bracelet en tissu</p>	<p>Z</p>  <p>Floor Leveler (Ø1/4"x20mm) 3 pcs Niveleurs de sol (Ø 1/4" x 20 mm)</p>

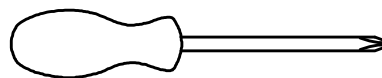

Assembly Tools Required (Not Included)
Outils D'assemblage Requis (Non Inclus)

STEP 1: Following below illustration:

ÉTAPE 1: Suivant l'illustration ci-dessous :

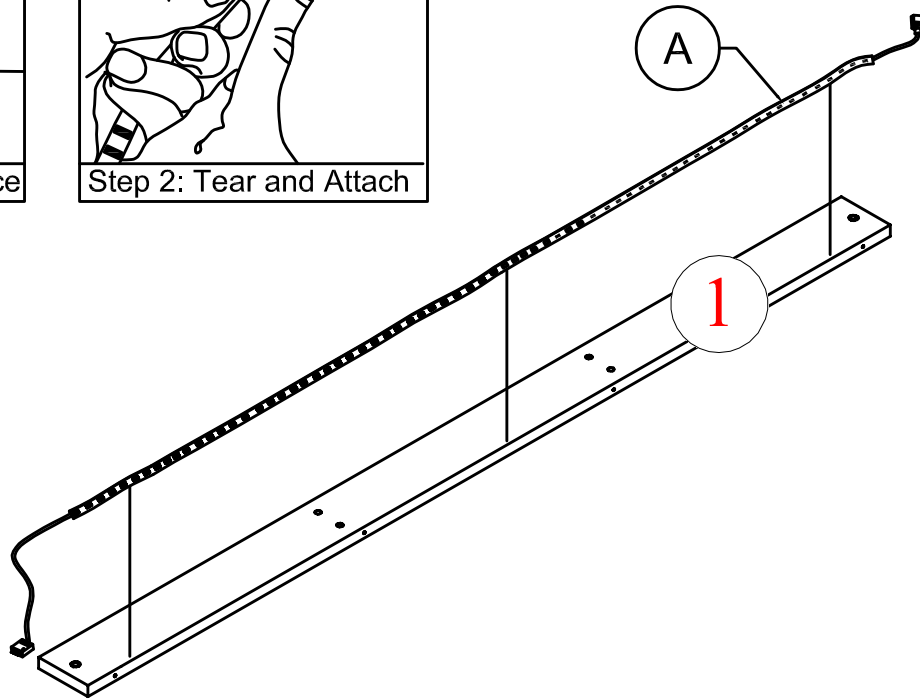
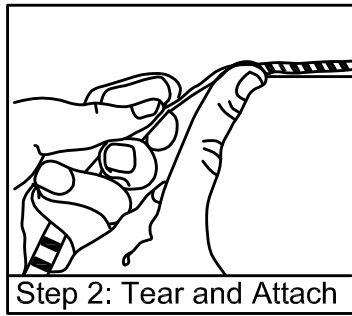
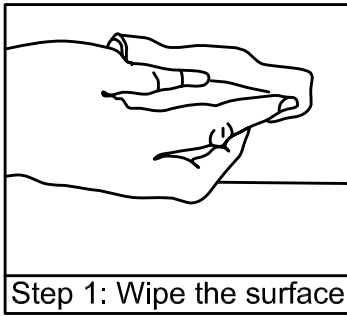
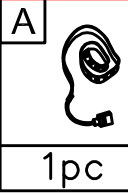

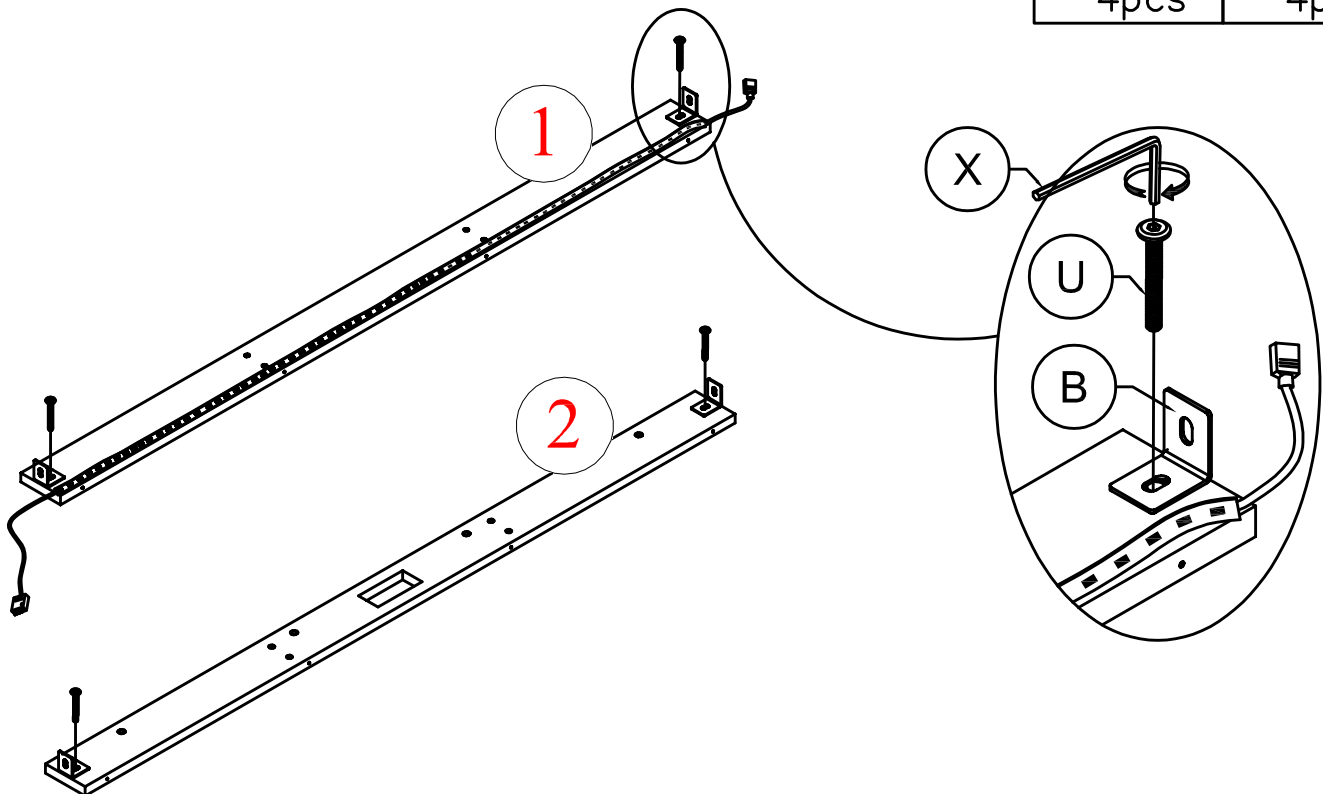
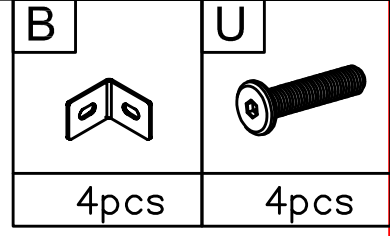

STEP 2: Following below illustration:

ÉTAPE 2: Suivant l'illustration ci-dessous :



STEP 3: Following below illustration:

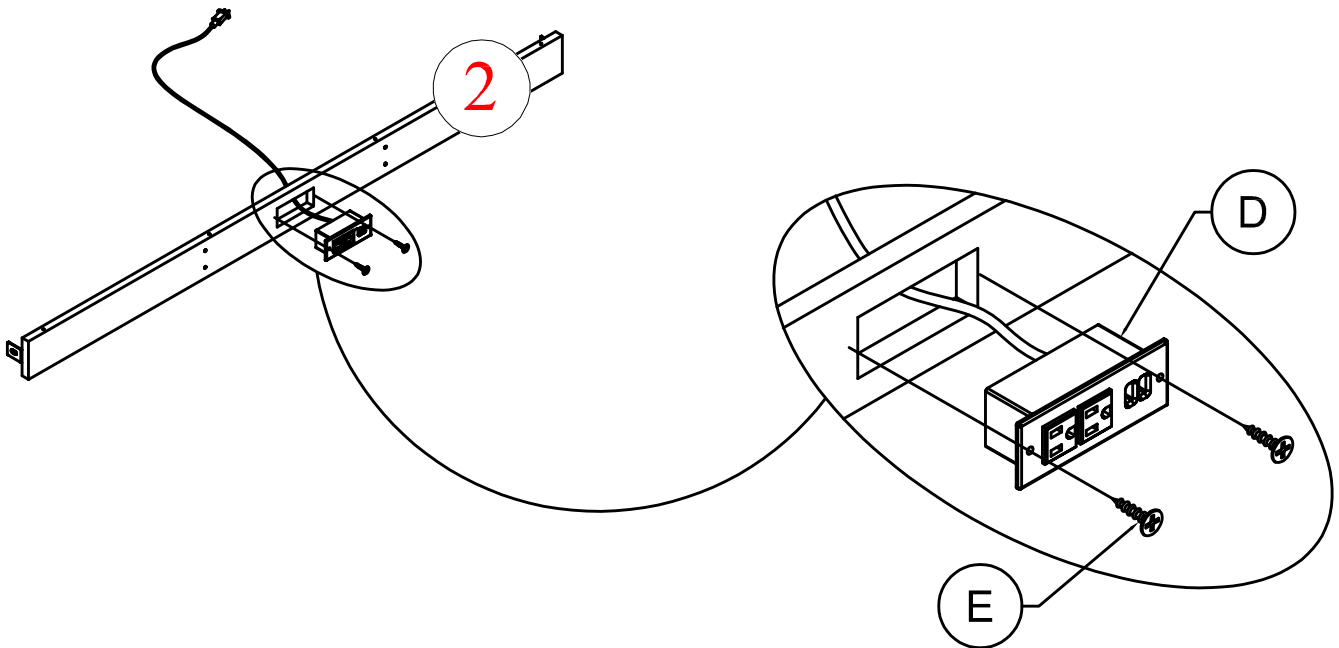

ÉTAPE 3: Suivant l'illustration ci-dessous :

D	E
	
1pc	2pcs

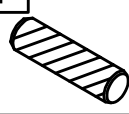

STEP 4: Following below illustration:

ÉTAPE 4: Suivant l'illustration ci-dessous :

F	G
	
4pcs	4pcs

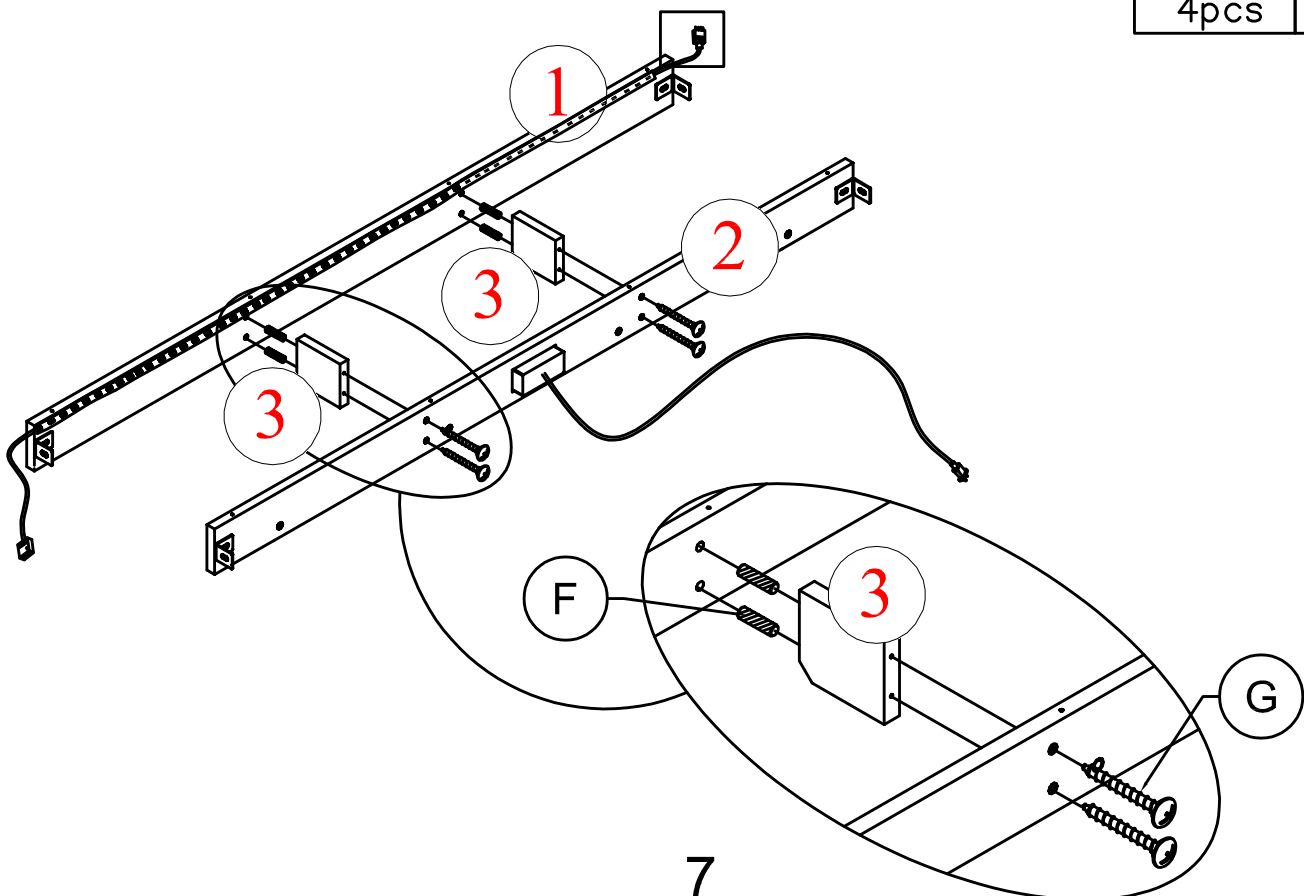

STEP 5: Following below illustration:

ÉTAPE 5: Suivant l'illustration ci-dessous :

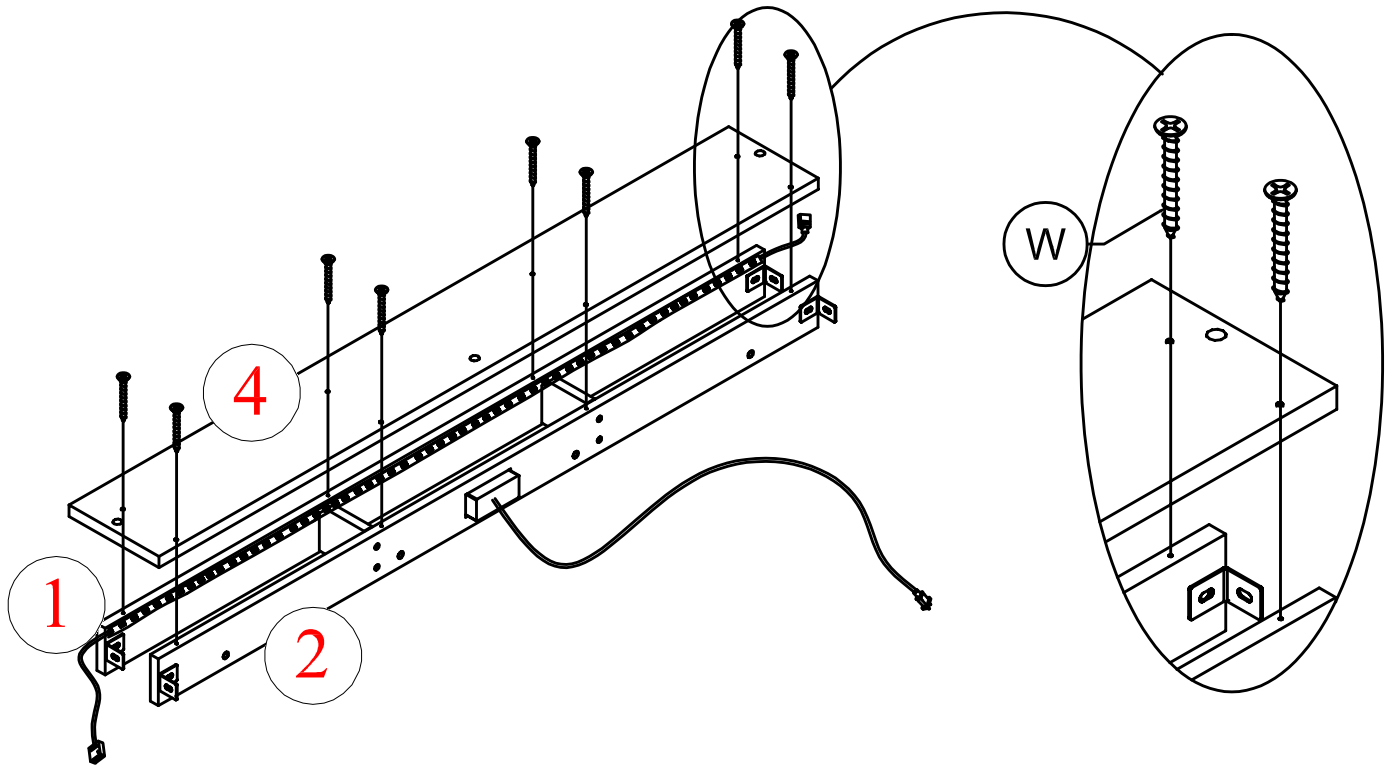
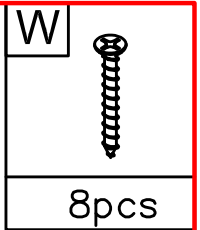

STEP 6: Following below illustration:

ÉTAPE 6: Suivant l'illustration ci-dessous :

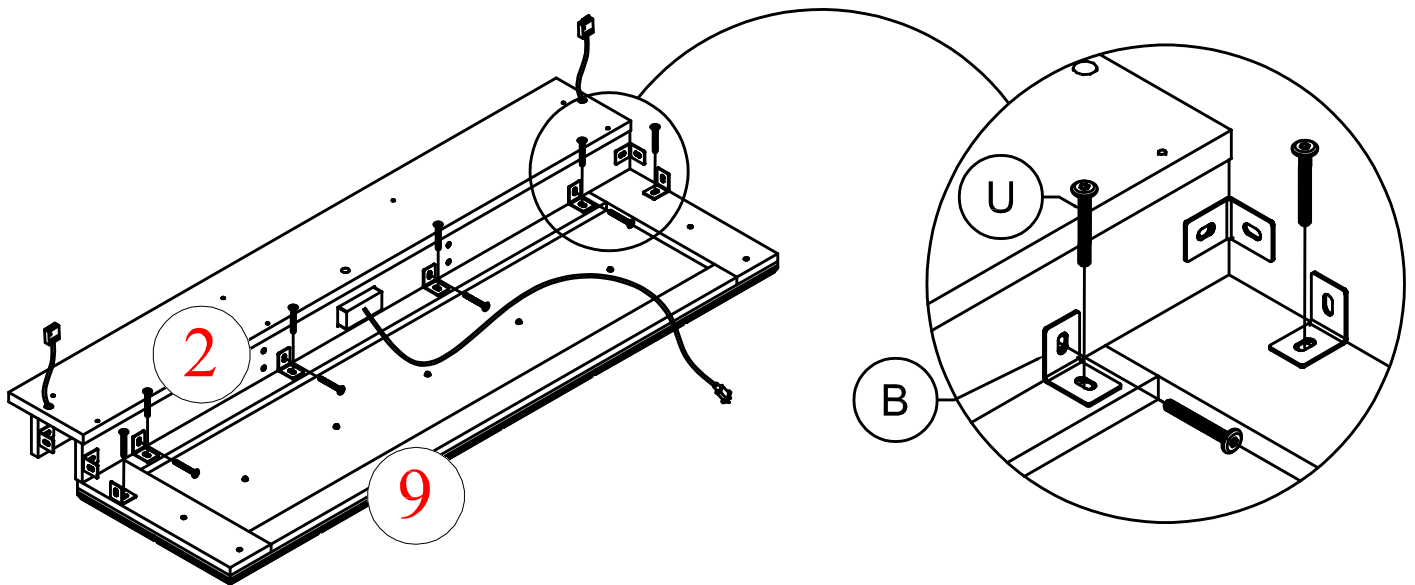
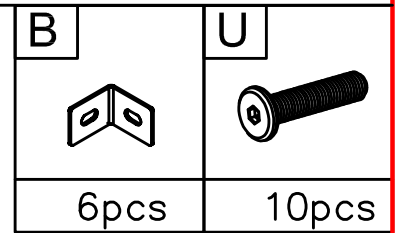

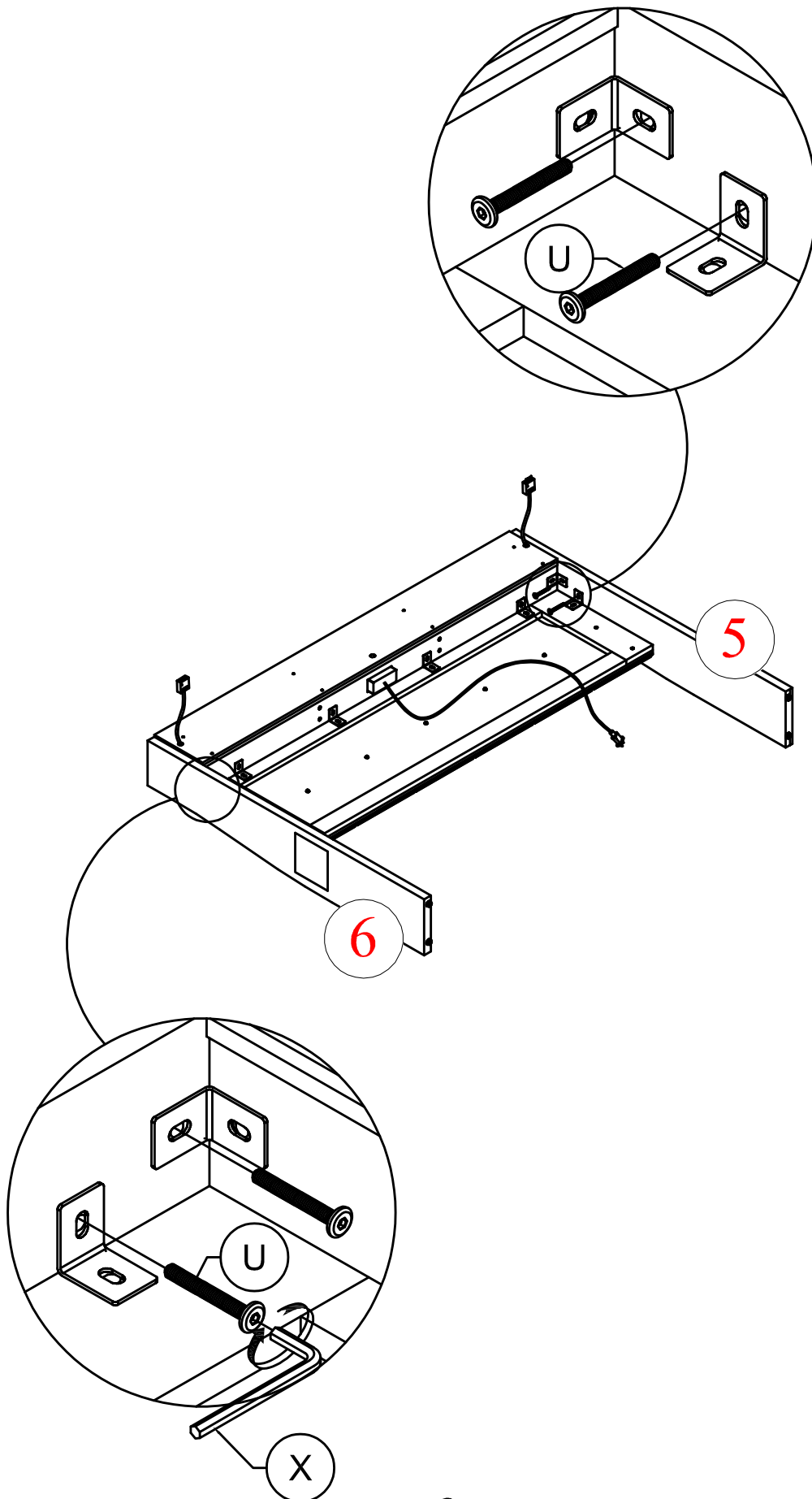
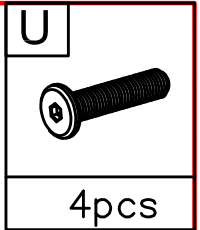

STEP 7: Following below illustration:

ÉTAPE 7: Suivant l'illustration ci-dessous :



STEP 8: Following below illustration:

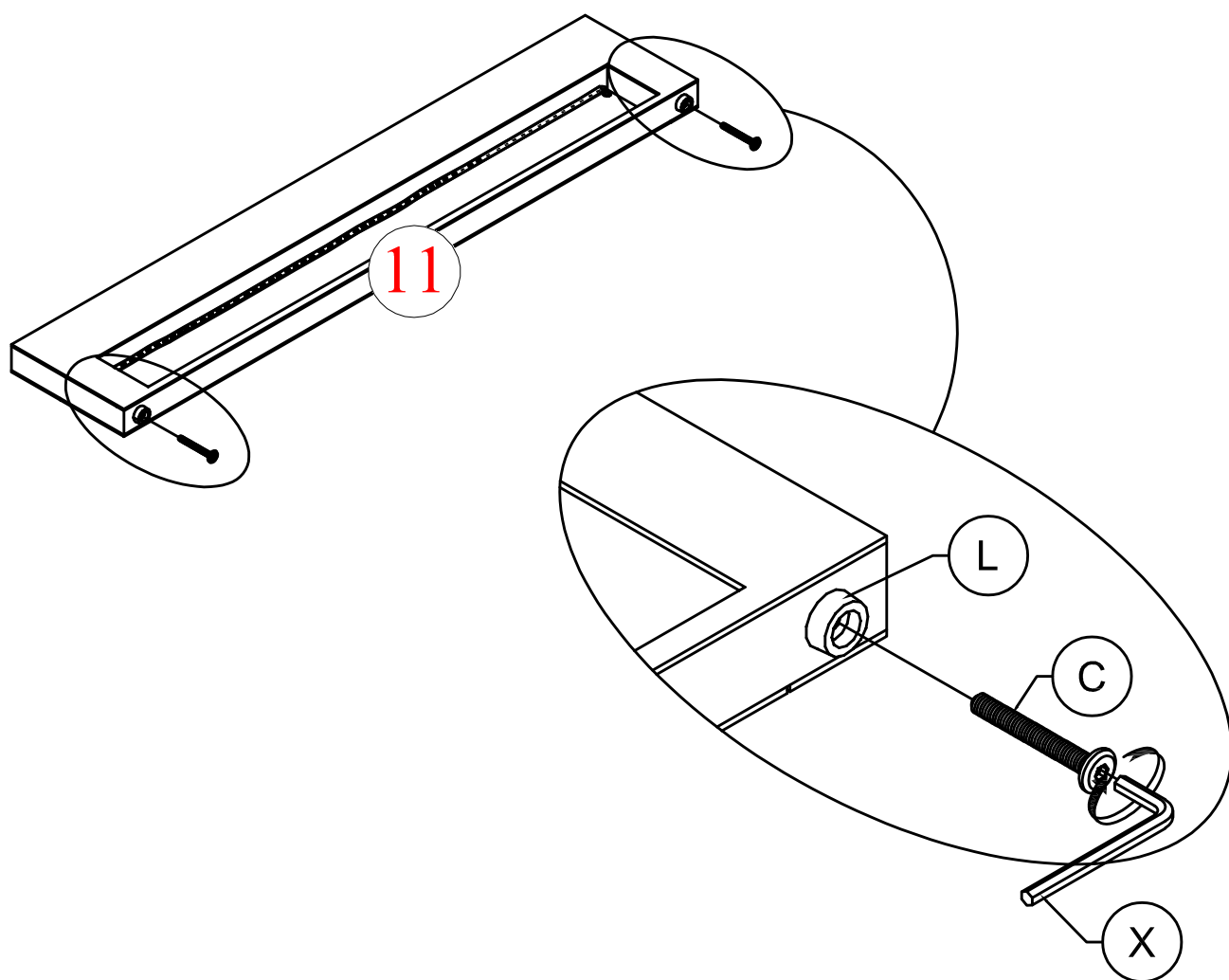

ÉTAPE 8: Suivant l'illustration ci-dessous :

C	L
	
2pcs	2pcs



STEP 9: Following below illustration:

ÉTAPE 9: Suivant l'illustration ci-dessous :

O-A	K	P
		
5pcs	5pcs	1pc

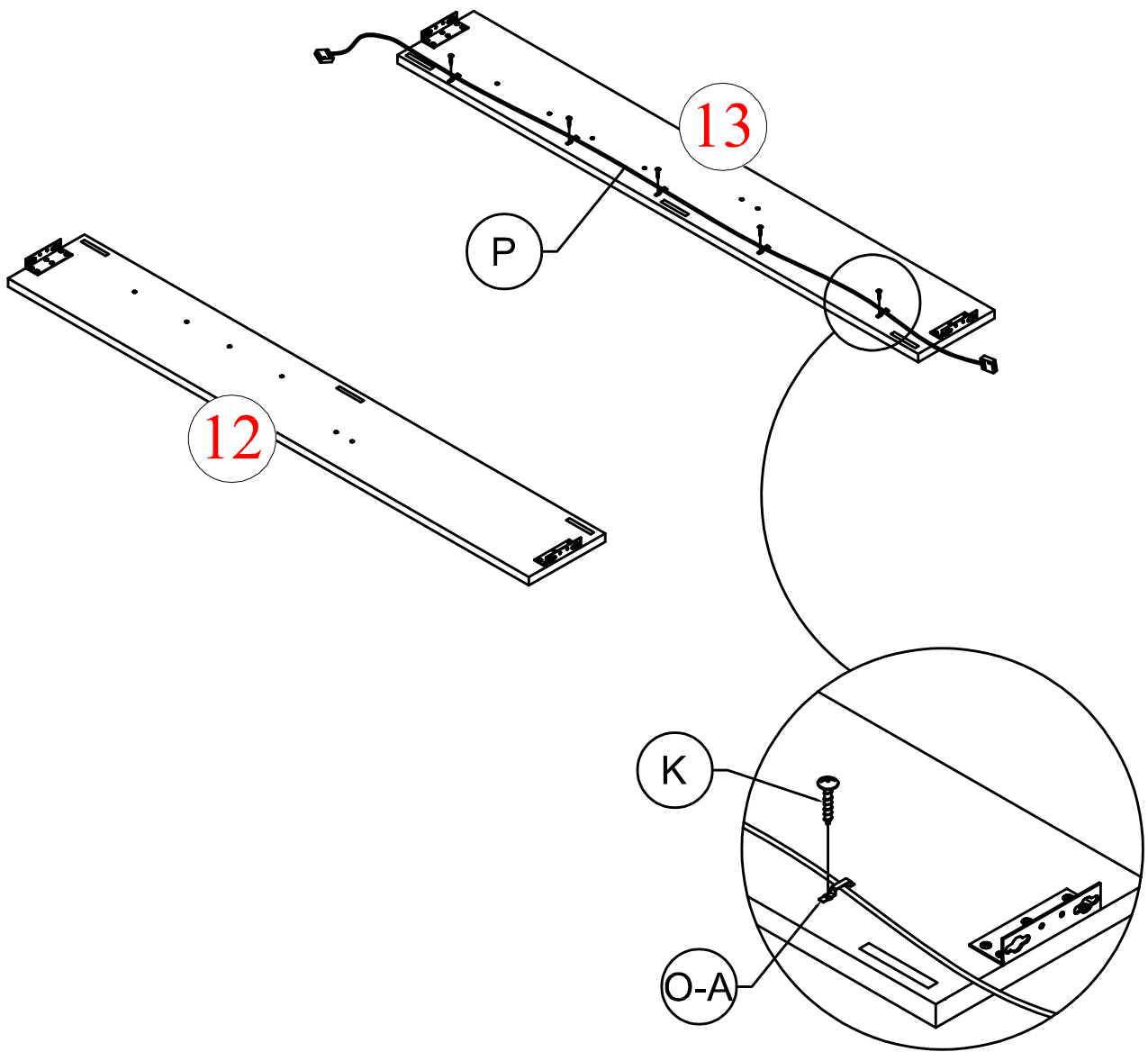

STEP 10: Following below illustration:
ÉTAPE 10: Suivant l'illustration ci-dessous :

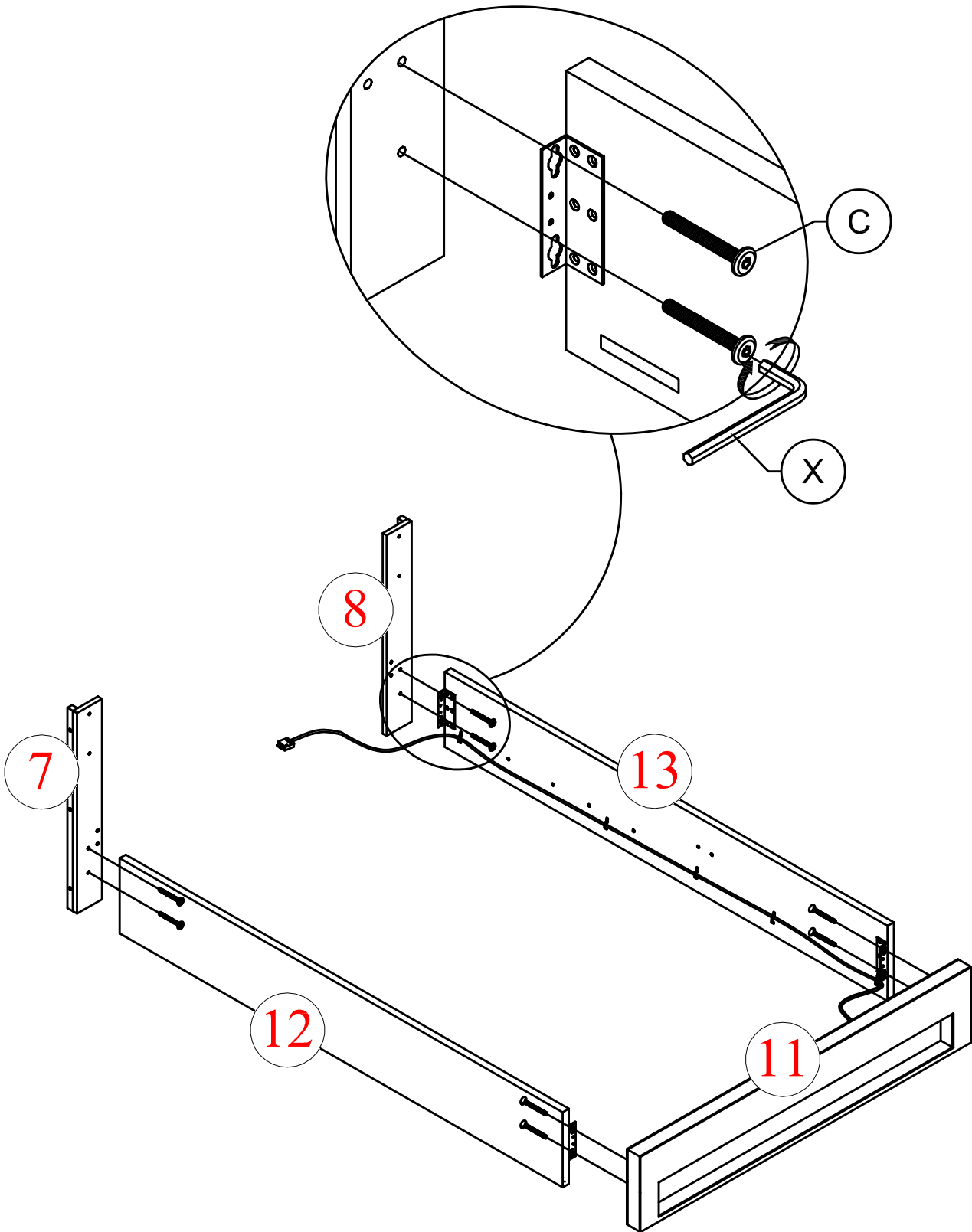
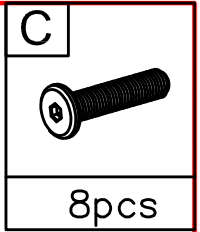

STEP 11: Following below illustration:
ÉTAPE 11: Suivant l'illustration ci-dessous :

I	J	C
4pcs	2pcs	12pcs

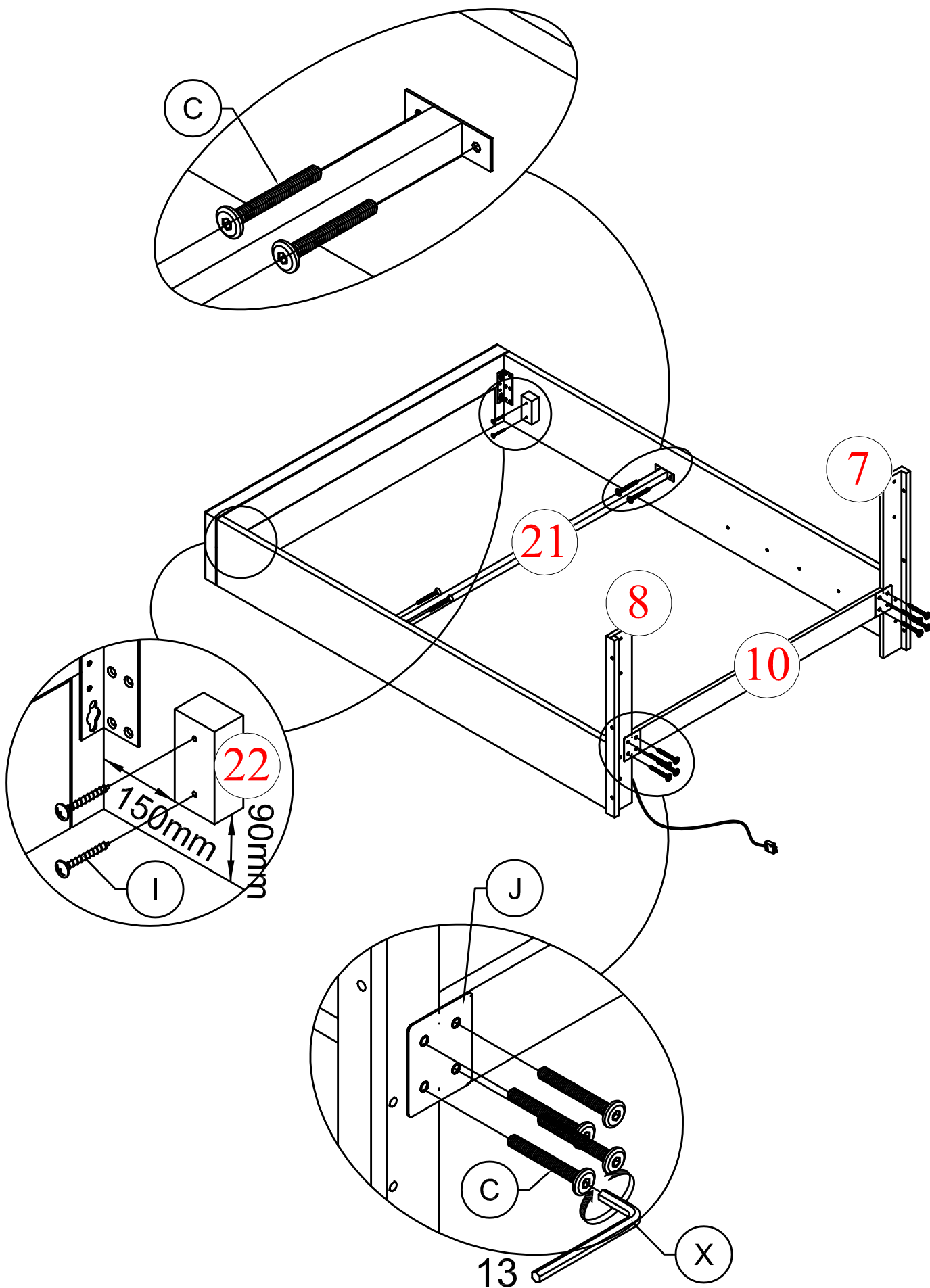

STEP 12: Following below illustration:

ÉTAPE 12: Suivant l'illustration ci-dessous :

H



6pcs

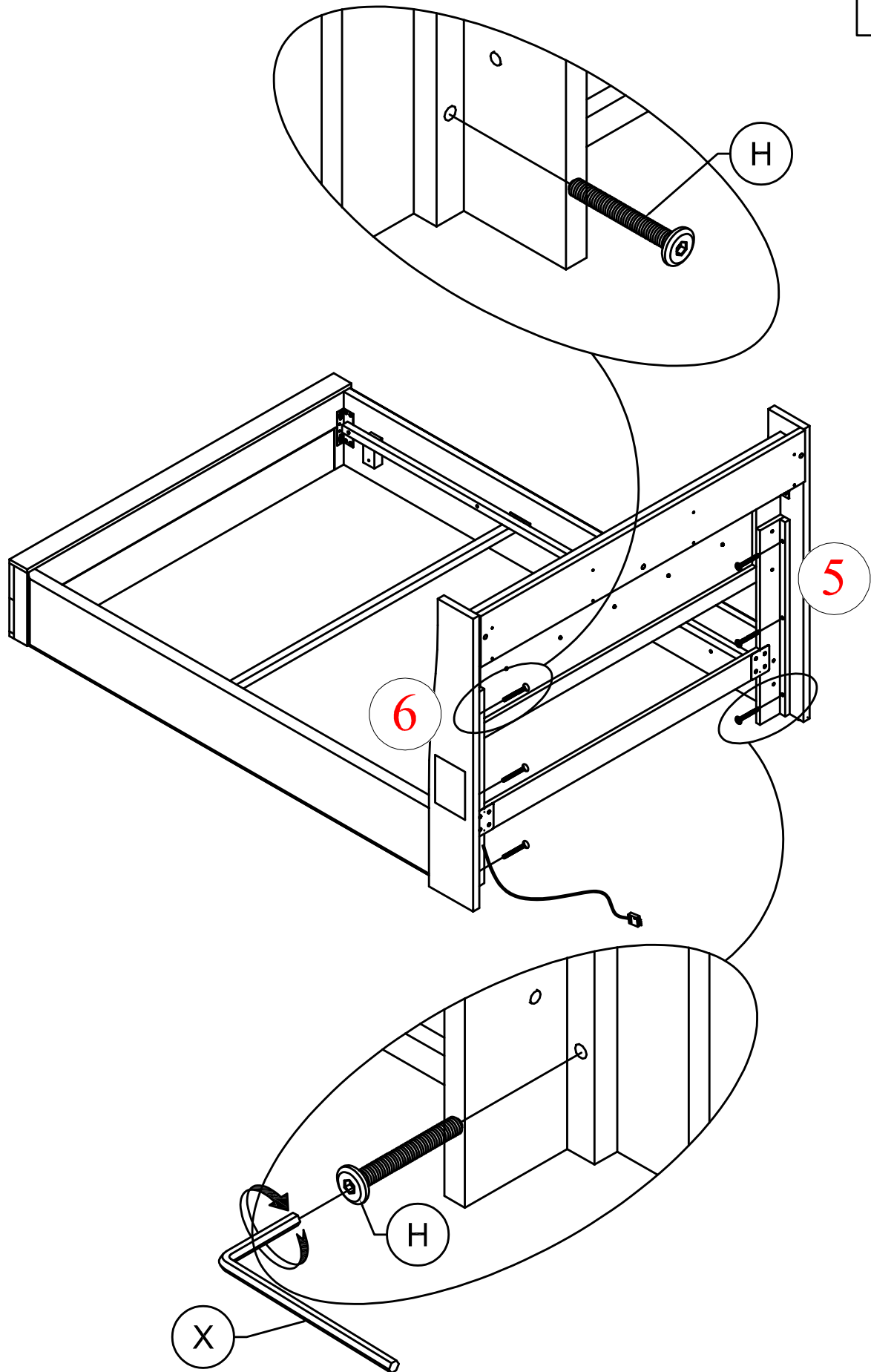

STEP 13: Following below illustration:

ÉTAPE 13: Suivant l'illustration ci-dessous :

U



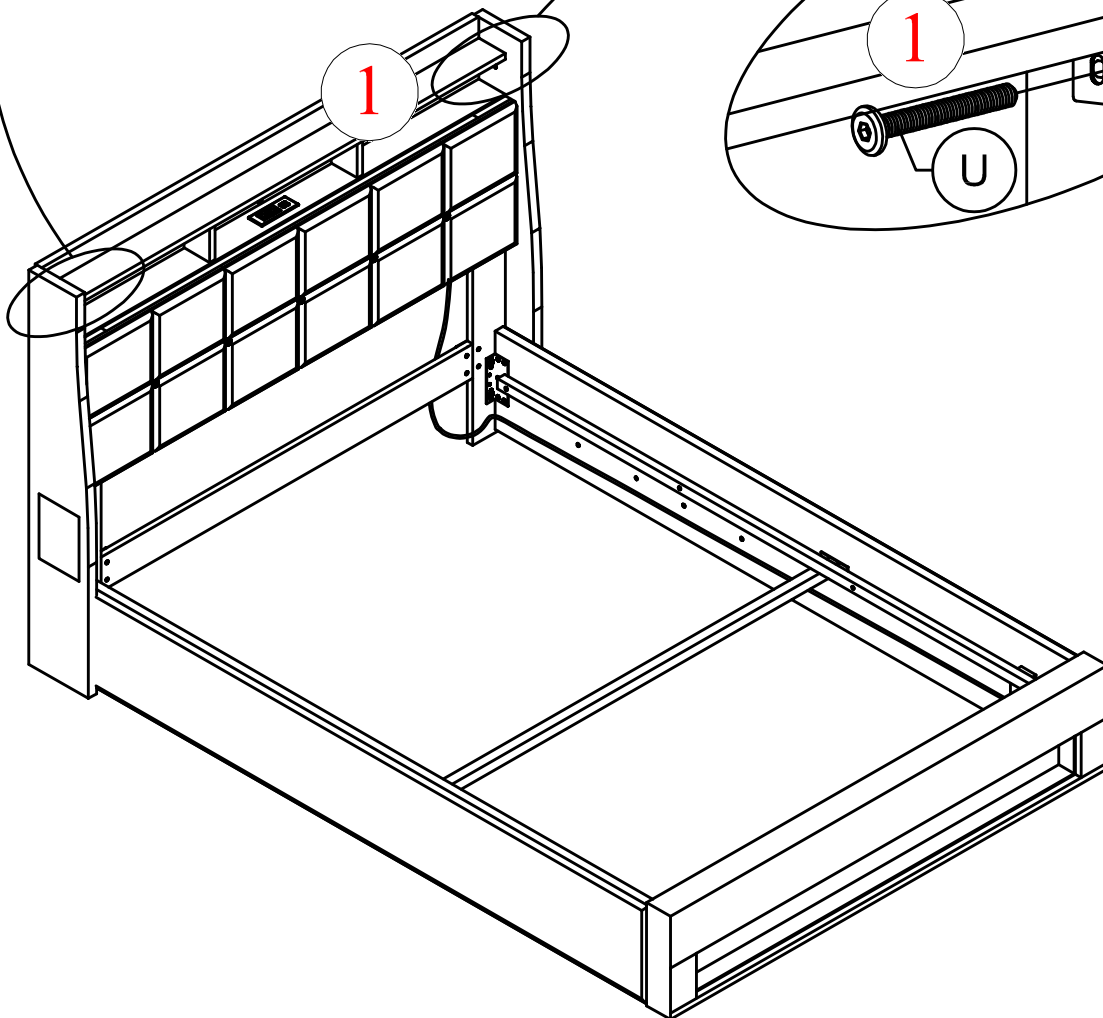
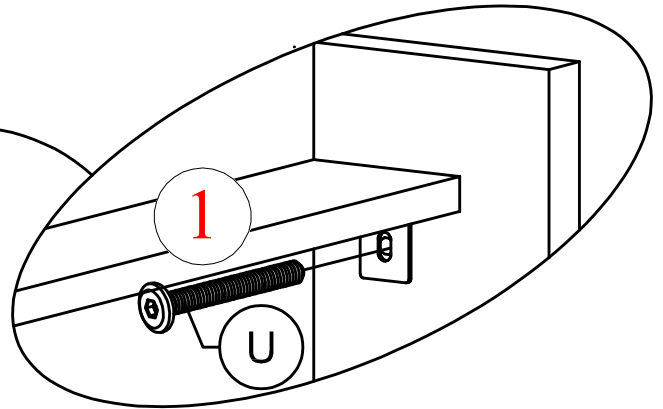
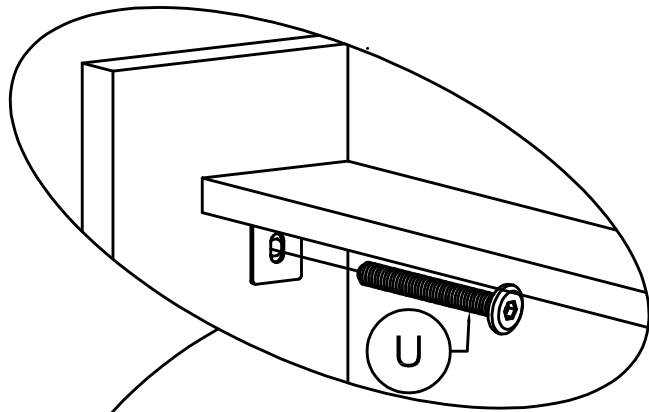

2pcs



STEP 14: Following below illustration:

ÉTAPE 14: Suivant l'illustration ci-dessous :

O-A	K
	
3pcs	3pcs

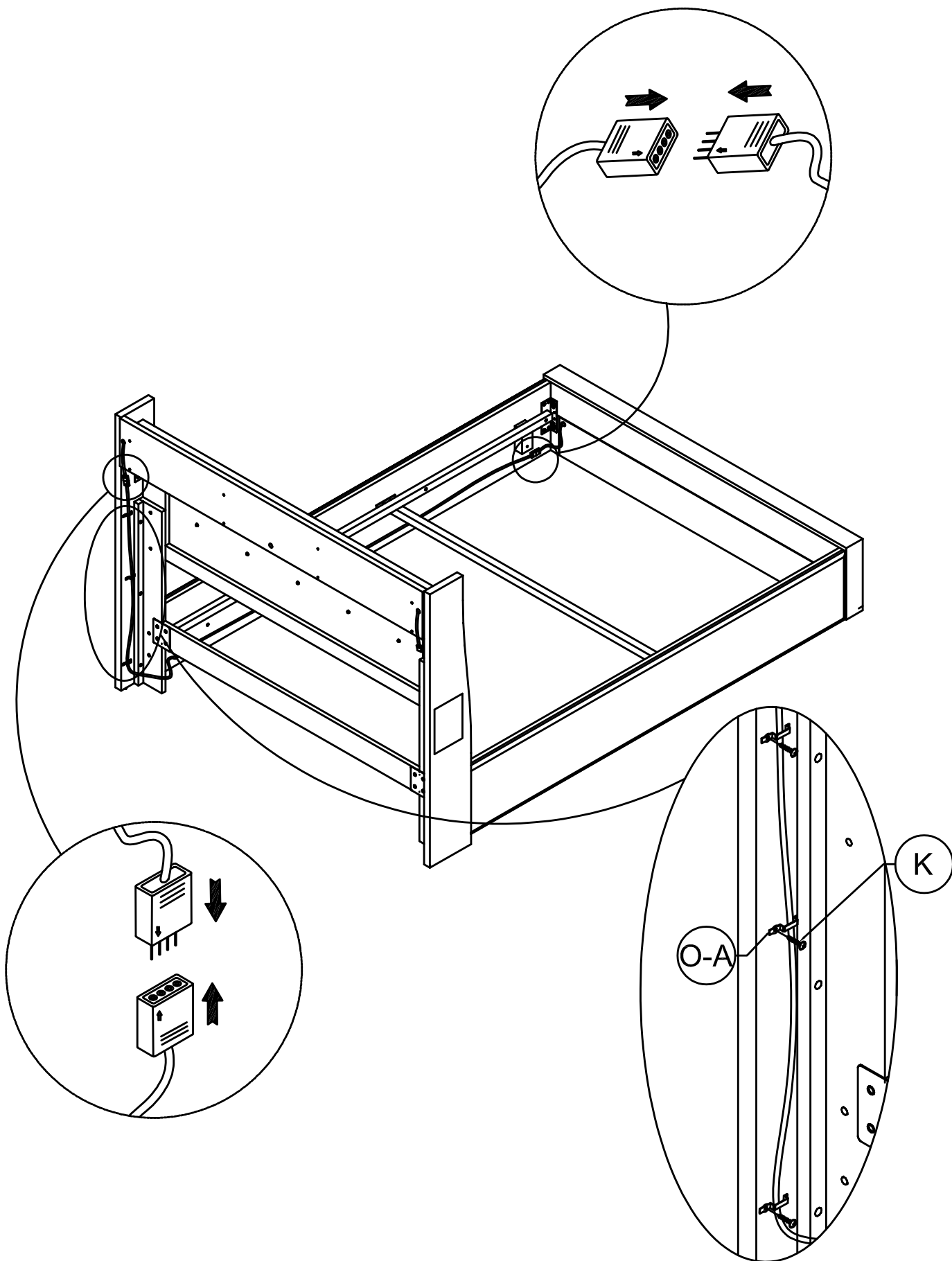

STEP 15: Following below illustration:

ÉTAPE 15: Suivant l'illustration ci-dessous :

Q



1pc

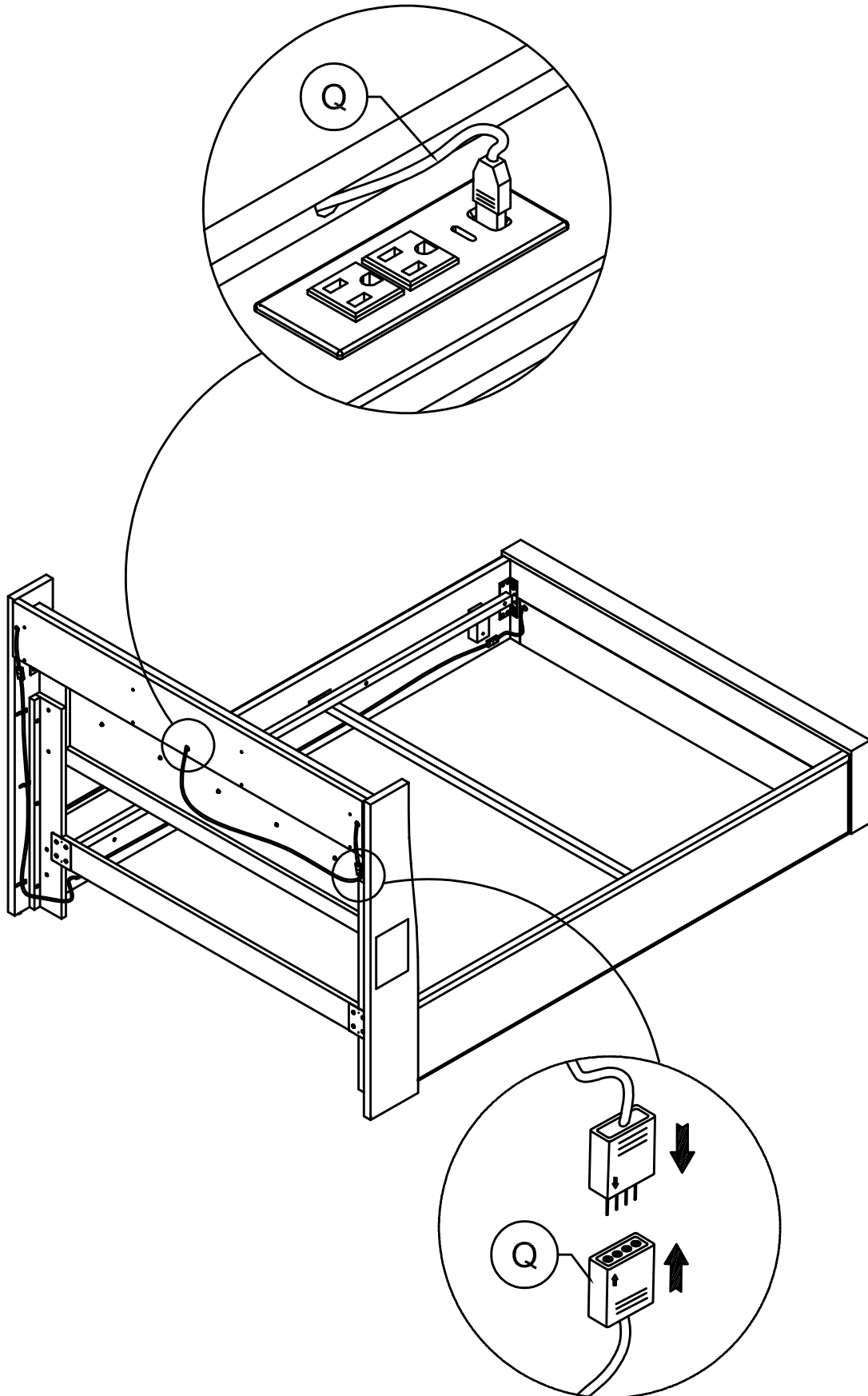

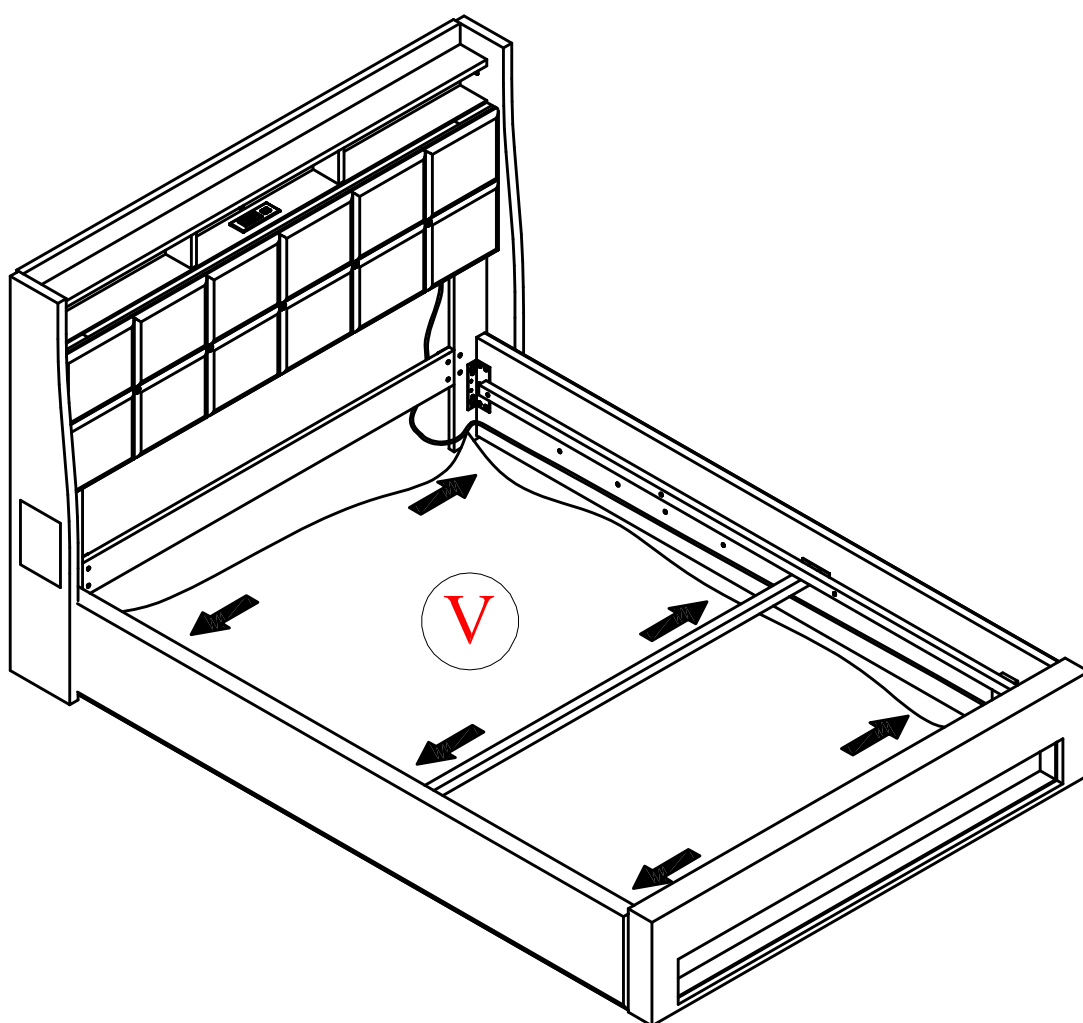

STEP 16: Following below illustration:
ÉTAPE 16: Suivant l'illustration ci-dessous :

V

1pc

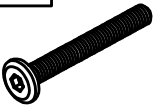

STEP 17: Following below illustration:

ÉTAPE 17: Suivant l'illustration ci-dessous :

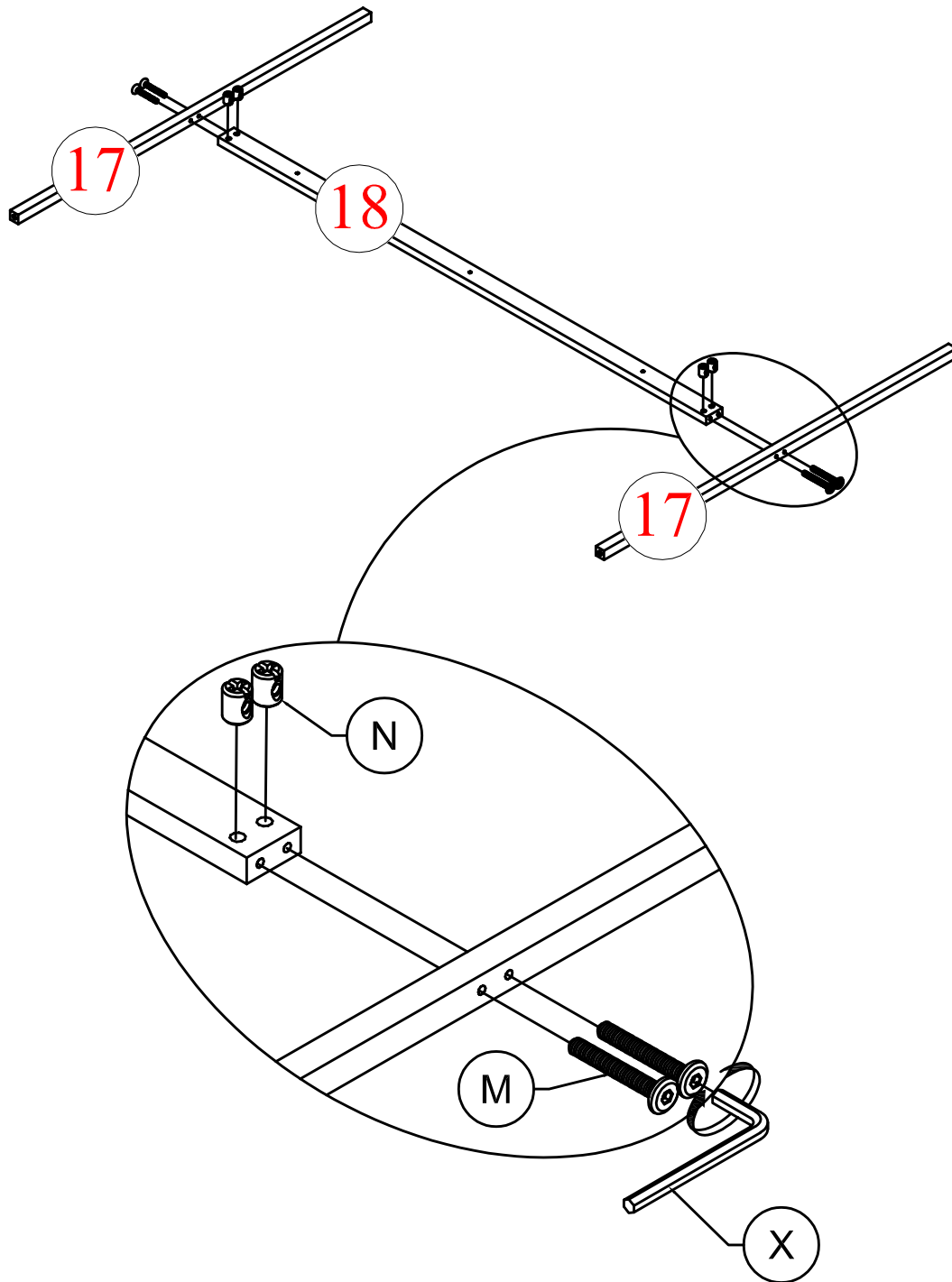
M	N
	
4pcs	4pcs



STEP 18: Following below illustration:

ÉTAPE 18: Suivant l'illustration ci-dessous :



H

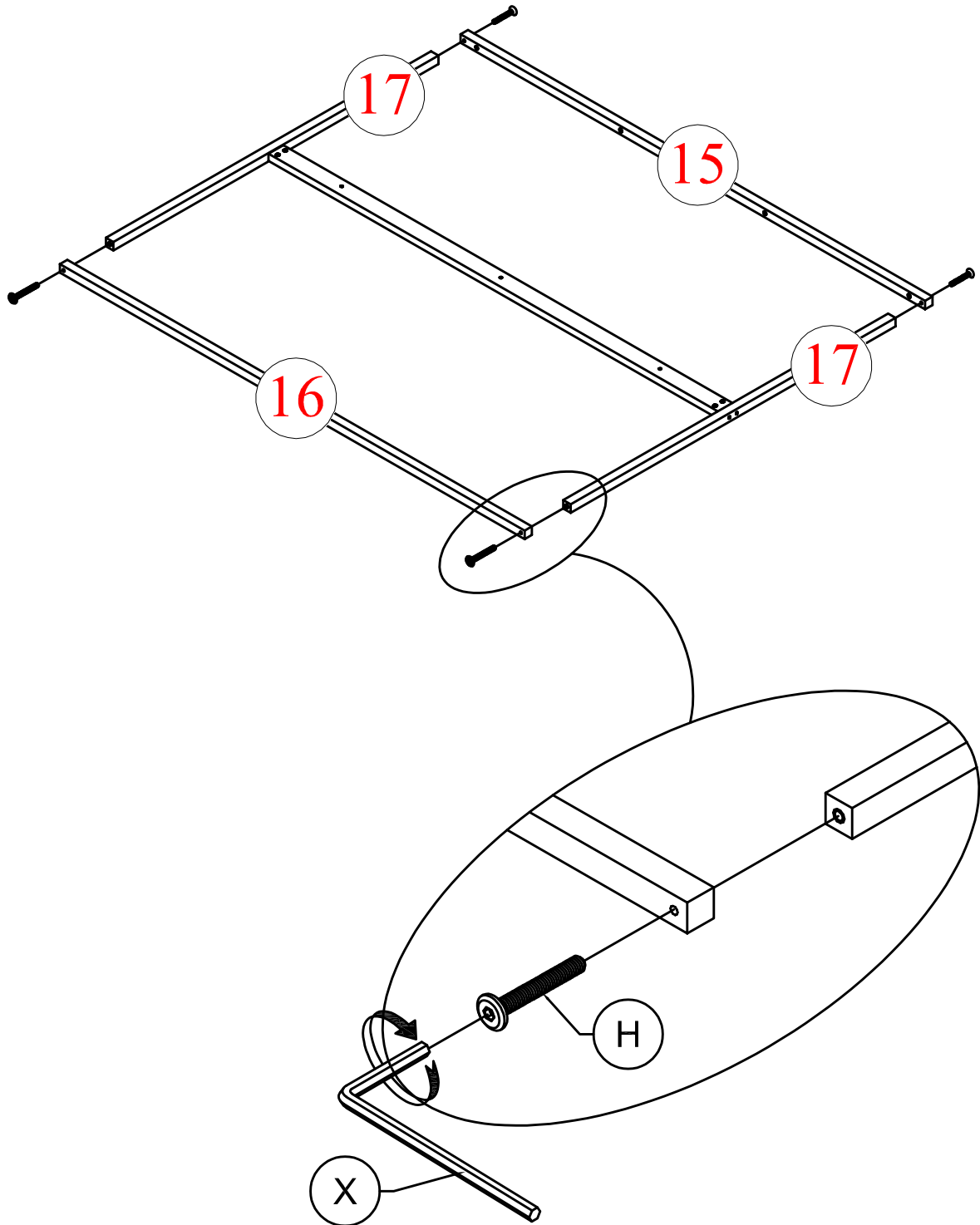

4pcs

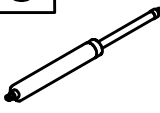

STEP 19: Following below illustration:
ÉTAPE 19: Suivant l'illustration ci-dessous :

S	T	R
		
2pcs	1pc	1pc

First, unscrew the nuts from the two R and T frames.
Then attach the S piston and screw the nuts back in place.

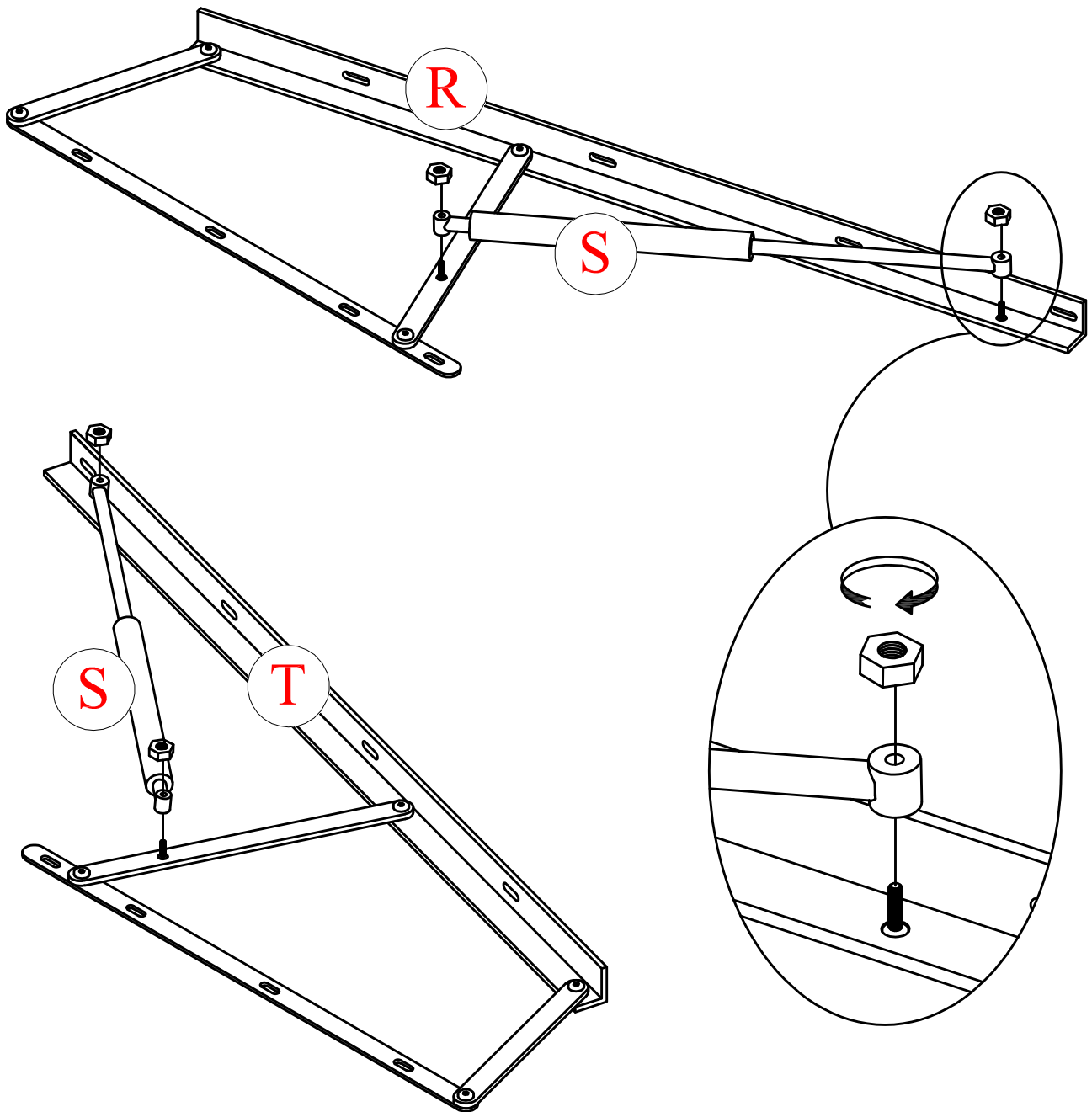

STEP 20: Following below illustration:

ÉTAPE 20: Suivant l'illustration ci-dessous :

C



8pcs

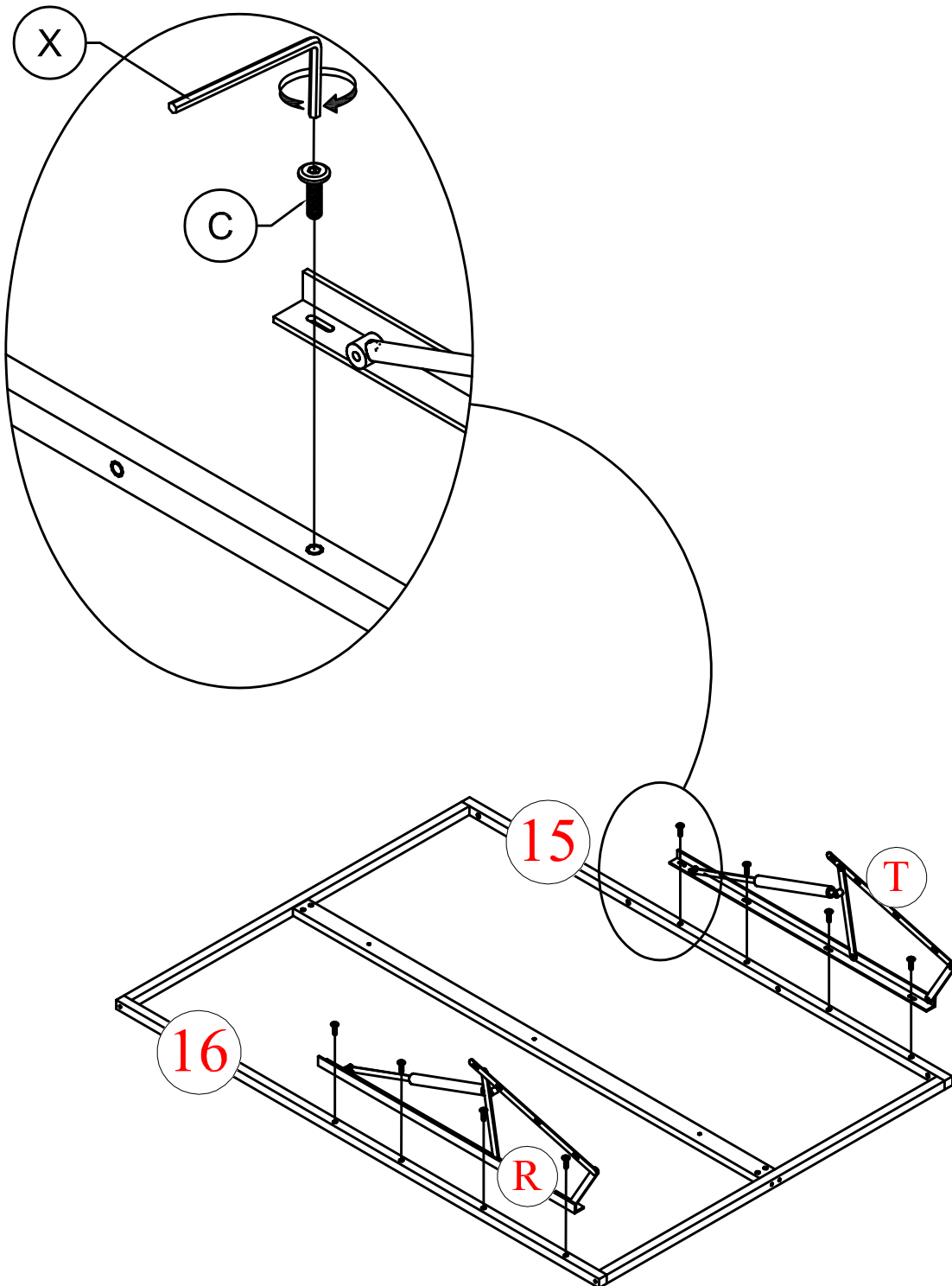

STEP 21: Following below illustration:

ÉTAPE 21: Suivant l'illustration ci-dessous :

C



8pcs

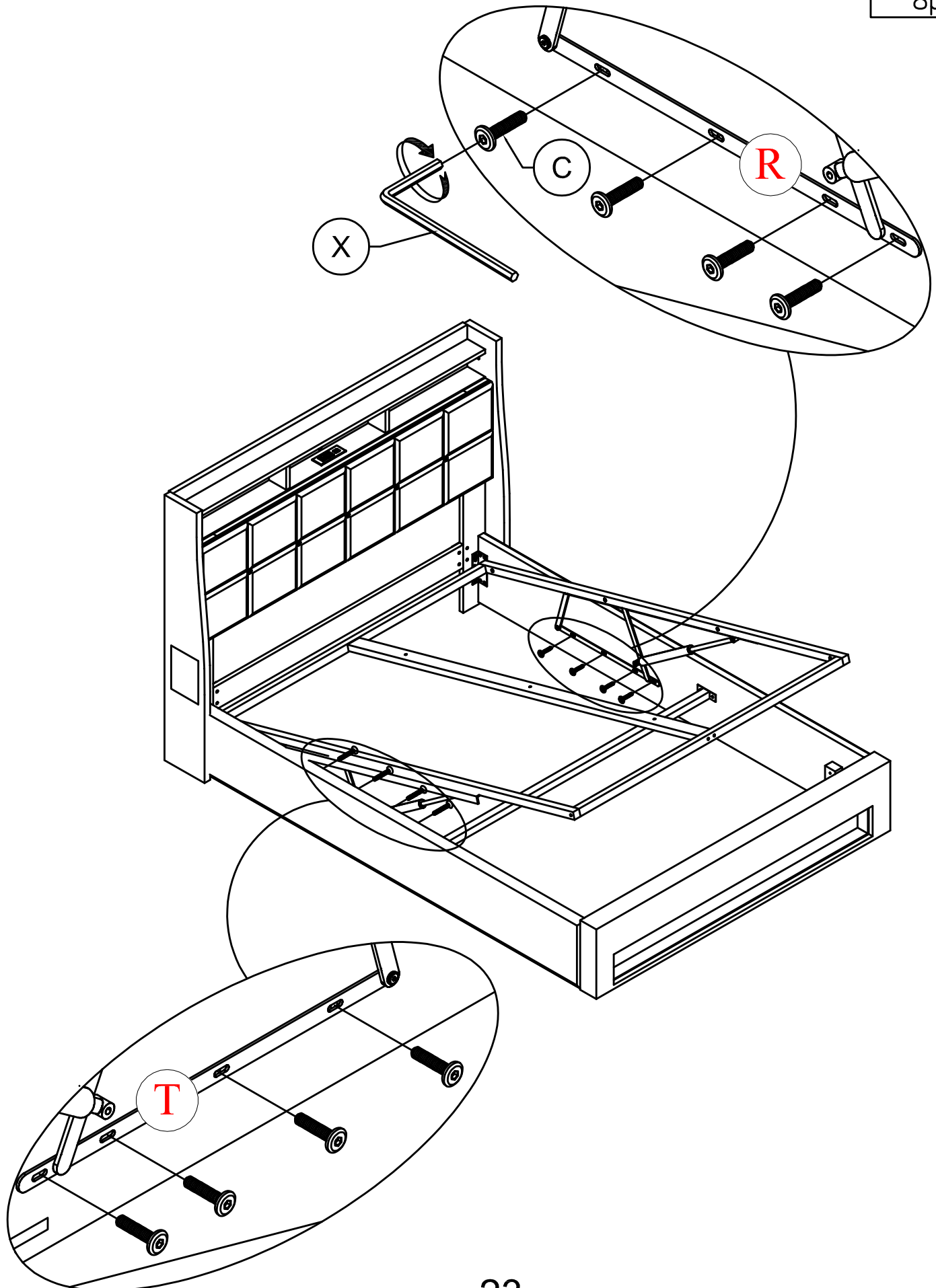

STEP 22: Following below illustration:

ÉTAPE 22: Suivant l'illustration ci-dessous :

Z

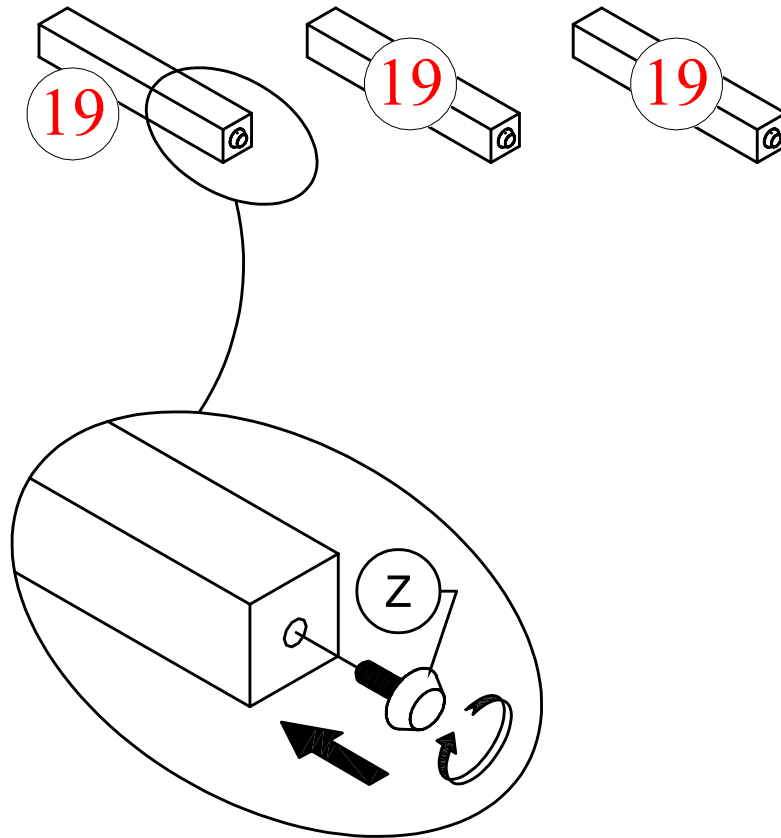
3pcs

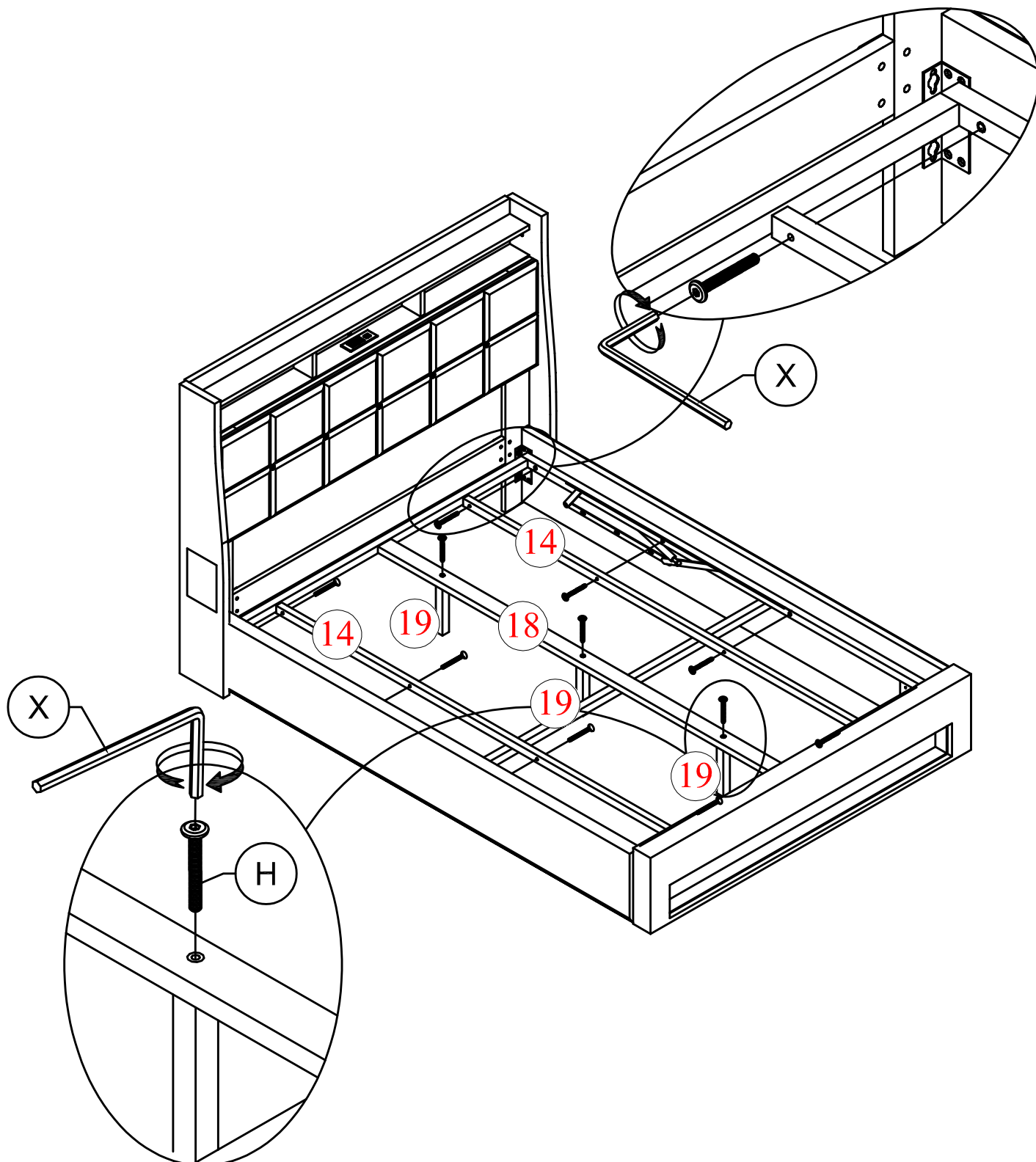

STEP 23: Following below illustration:
ÉTAPE 23: Suivant l'illustration ci-dessous :

H

11pcs



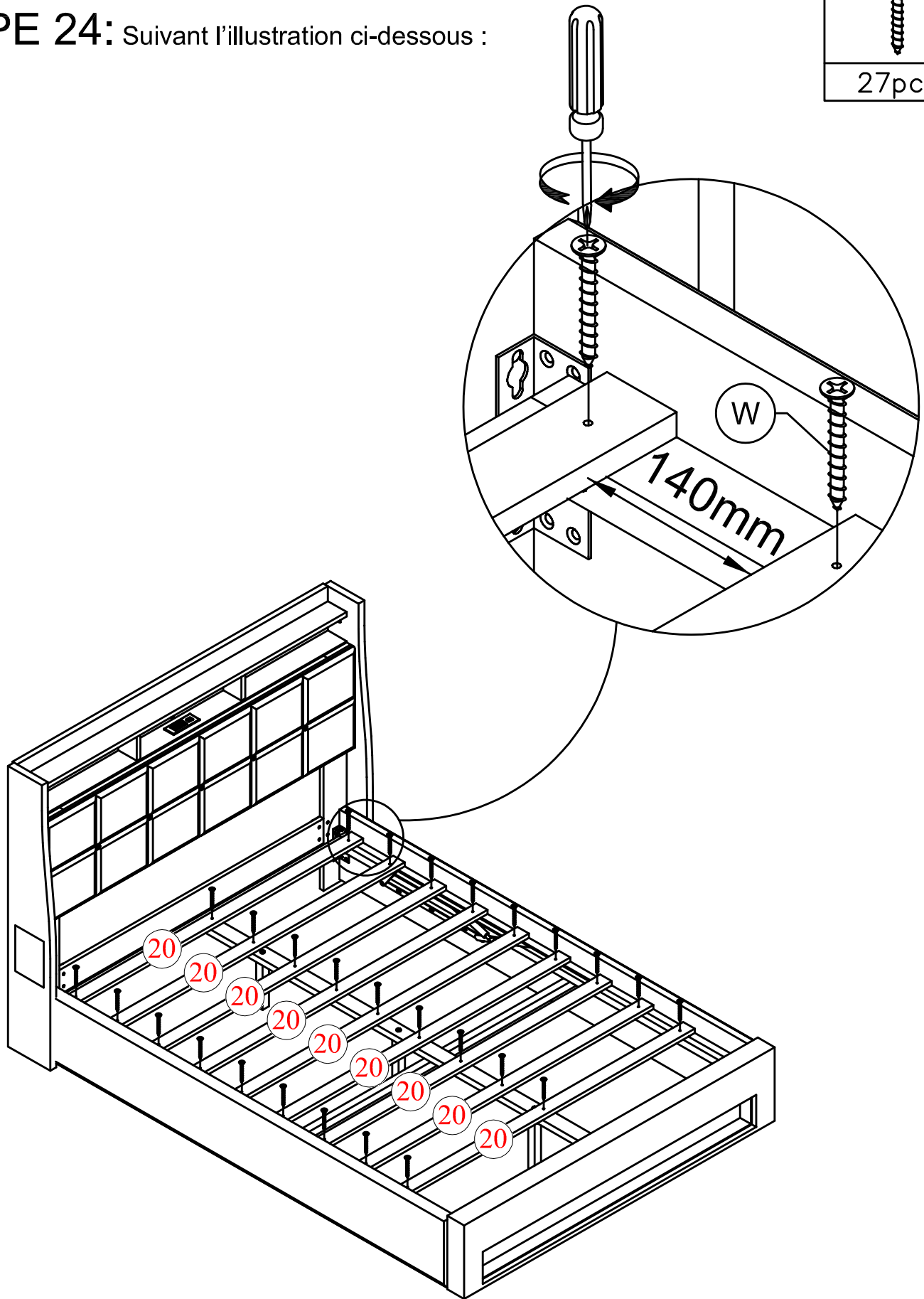
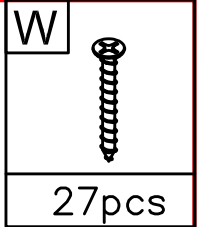

STEP 24: Following below illustration:

ÉTAPE 24: Suivant l'illustration ci-dessous :



STEP 25: Following below illustration:

ÉTAPE 25: Suivant l'illustration ci-dessous :

Y	W
	
1pc	3pcs

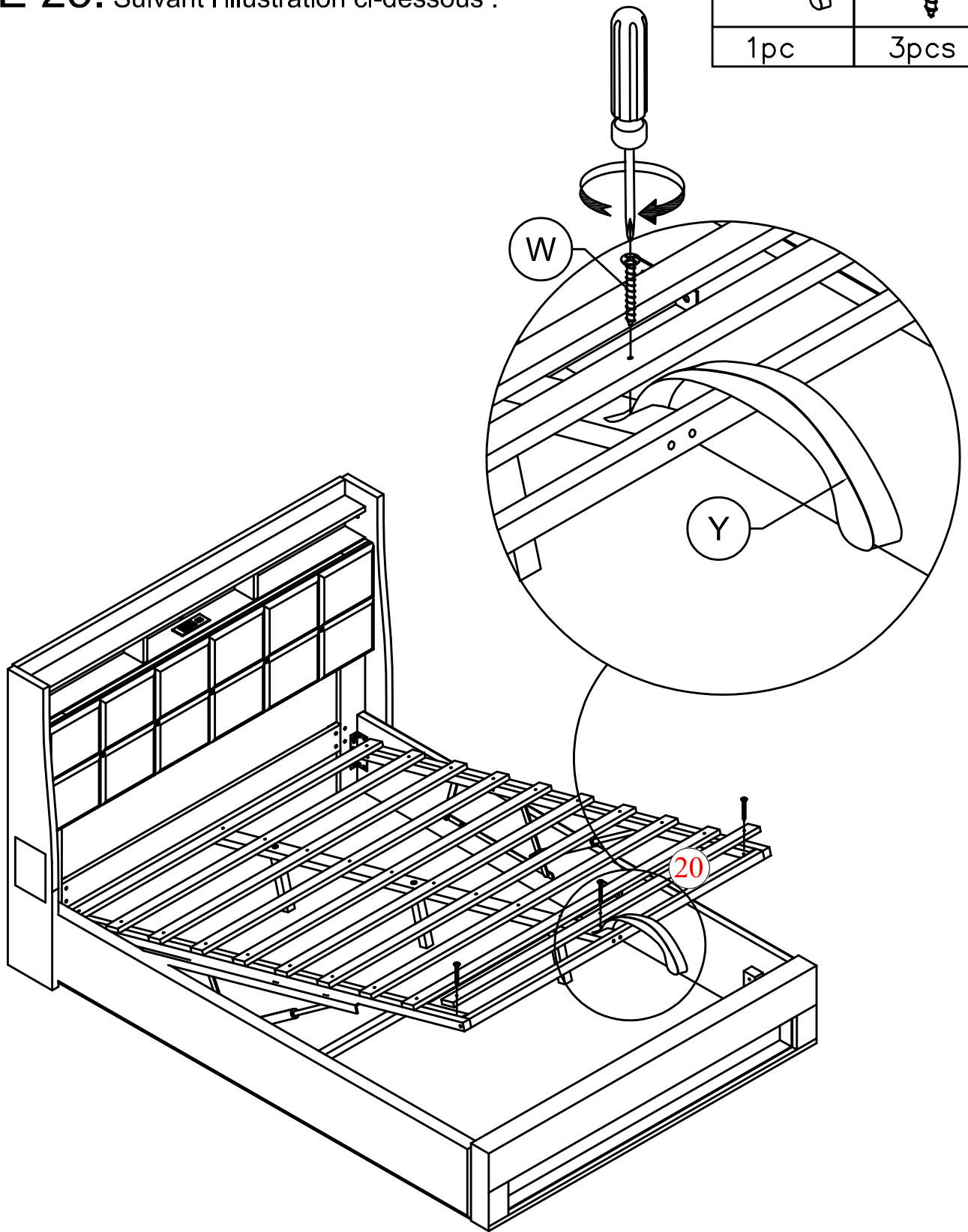

FINISH FINIR

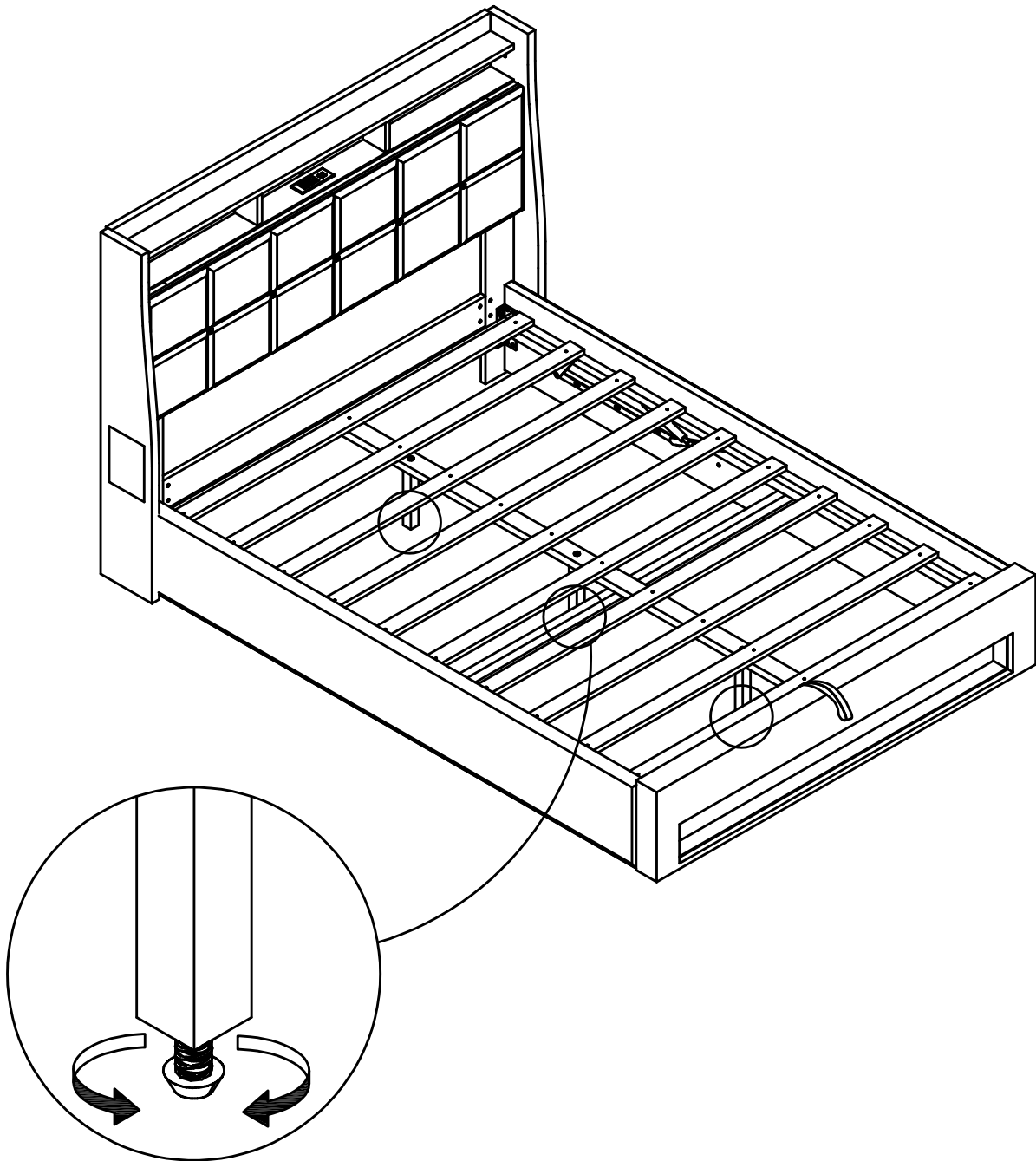

Rotate counterclockwise to increase the length of Floor Leveler, and raise that corner. Rotate clockwise to lower that corner.