









Item Number : F00001/F00002

Read instructions carefully prior to assembly.

Thank you for purchasing this quality product. Check carefully for small parts which may come loose during shipment. Remove all components from pack and place top down on soft surface such as carpet or cloth to prevent scratching the finish. Identify and count all parts as specified below.

It is recommended to use two or more persons during the assembly process.

Hardware List				
No.	Description	Sketch	Size	Q.ty
1	Allen Key		M4x58x23	1 pc
2	Allen Bolt		1/4 x 16mm	8 pcs
3	Allen Bolt		1/4 x 40mm	10 pcs
4	Spring Washer		1/4 x Ø12 x 1mm	18 pcs
5	Flat Washer		1/4 x Ø16 x 2mm	18 pcs

Parts List			
No.	Description	Sketch	Q.ty
A	Cocktail Table top		1 pc
B	Cocktail Legs Frame		2 pcs
C	Cocktail Bottom Panel		1 pc
D	Cocktail Apron		2 pcs

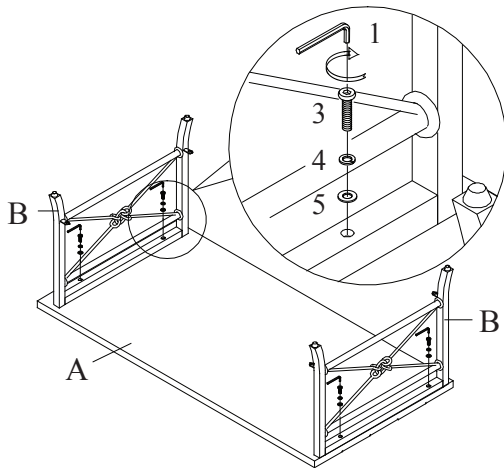

Step 1: Place Table Top (A) on a flat, soft surface such as a carpet or a cloth to prevent scratching the table finish. Attach two Legs Frame (B) to the Table Top (A) by using Flat Washers (5), Spring Washers (4), Bolts (3) and Allen Key (1). DO NOT fully tighten the bolts.

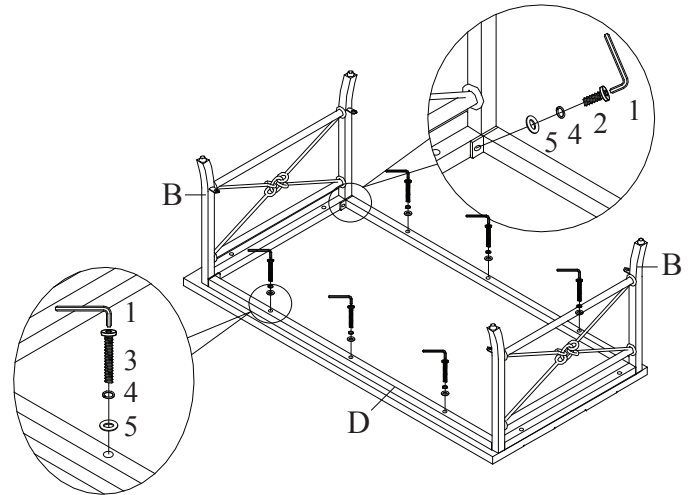

Step 2: Attach the Stretchers (D) to the Legs Frame (B) by using Bolts (2) and Allen Key (1). Connecting to table top by using Flat Washers (5), Spring Washers (4), Bolts (3) and Allen Key (1).

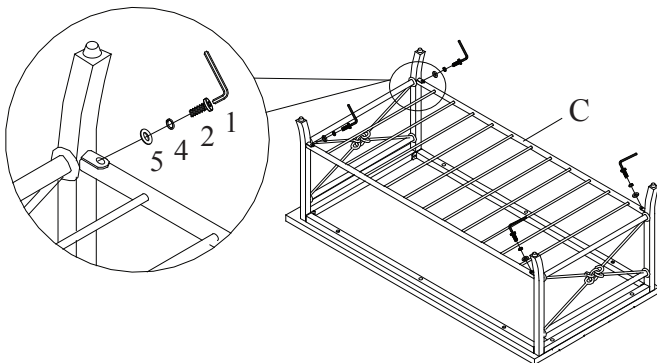

Step 3: Insert the Bottom Panel (C) into the Legs by using Flat Washers (5), Spring Washers (4), Bolts (2) and Allen Key (1).

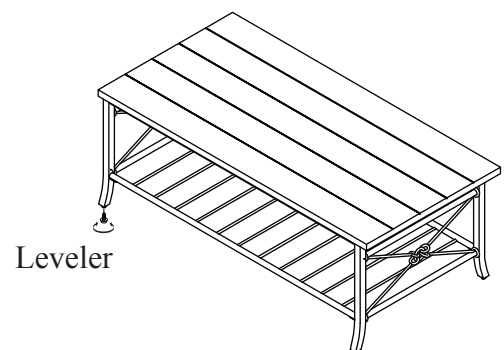

Step 4: Turn over the table and tighten all bolts carefully. Assembly is completed. If levelling is necessary, adjust the levelers turn clockwise or counter clockwise.