

Owner's Manual

Household Freezer

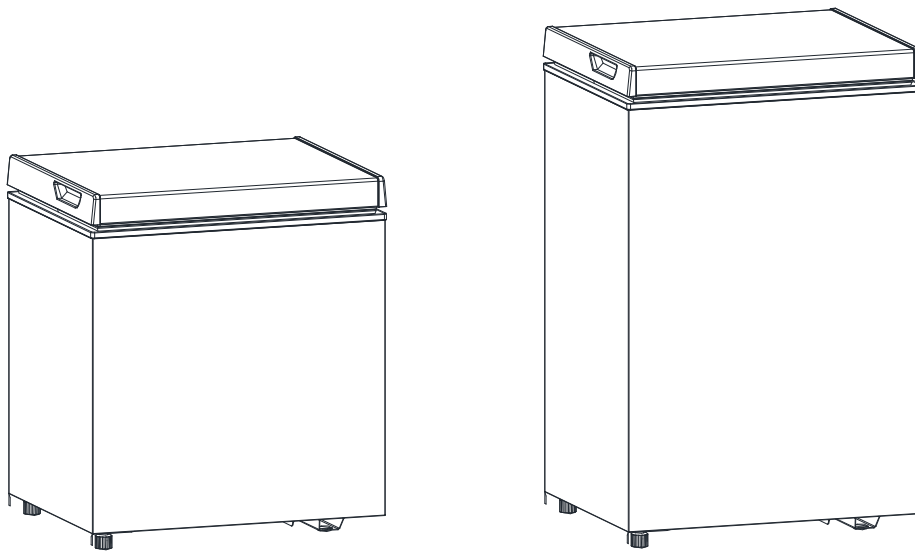

Model:BD-50 BD-80

Thank you for purchasing this product! Please read the instructions carefully before use. If you have any questions about the product, please contact us via Amazon Message or customer service number: 213-4467172 or 661-4358826.

TABLE OF CONTENTS

Table of Contents	1
Package Content	2
Important Safeguards	2
Getting to know your Freezer	4
Preparing Your Freezer for Use	4
Unpacking your Freezer	4
Connecting Your Freezer	5
Temperature Control	5
Operating Procedures & Maintenance	6
Moving Your Freezer	6
Defrosting Your Freezer	6
Cleaning Your Freezer	7
Troubleshooting	7
Technical Specifications	8

PACKAGE CONTENT

Freezer Unit	1 pc
Shelf	1 pc
Owner's Manual	1 pc

IMPORTANT SAFEGUARDS

When using your FREEZER, basic safety precaution should be followed to reduce the risk of fire, electric shock, and injury to persons or property. Read all instructions in this owner's manual carefully.

Use this appliance only for its intended purpose as described in this owner's manual.

WARNING: This appliance is intended to be used in households and similar applications such as

- staff kitchen areas in shops, offices and other working environments;
- farm houses and by clients in hotels, motels and other residential-type environments;
- bed and breakfast type environments;
- catering and similar non-retail applications.

- The appliance must be correctly installed and connected to the power supply in accordance with the installation instructions before it is used. (See: "Preparing Your Freezer for Use").
- The main power supply must be properly grounded.
- This freezer must be positioned so that the plug is accessible. Never unplug your unit often by pulling on the power cord. Always grasp the plug firmly and pull it straight out from the outlet.

- Do not use an extension cord as this can negatively affect the performance of the unit. If you must use an extension cord, use 18AWG minimum size and rated no less than 1875 watts.

- When transporting the refrigerator, keep the unit in the upright position. Do not tilt the appliance beyond 45° or place the unit in upside-down position. Do not tip over.

- Do not touch the cooled surfaces while the appliance operates, especially not with wet hands, because the skin may stick to the cold surfaces.

- It is recommended that the refrigerator is positioned away from any combustible sources such as gas, petrol, alcohol, lacquer and banana oil, etc. The aforementioned objects should not be stored in the refrigerator under any circumstances.

- If the unit fails to cool properly, dispose of spoiled food as needed.

- Unplug your Freezer before cleaning or making any repairs. **NOTE:** *If for any reason this product requires service, we strongly recommend that a certified technician perform the service.*

- Do not defrost the appliance with other electric devices (hair dryer etc.) and never scrape the ice or frost layer with sharp tools. Warning: Do not damage the refrigerant circuit.
- The rating plate is inside the appliance or outside on the rear or side wall.
- This appliance is not intended for use by persons (including children) with reduced physical, sensory or mental capabilities, or lack of experience and knowledge, unless they have been given supervision or instruction concerning use of the appliance by a person responsible for their safety. Children should be supervised to ensure that they do not play with the appliance.
CAUTION: To prevent A Child From Being Entrapped, Keep Out Of Reach Of Children And Not In The Vicinity Of Freezer.
- Do not run cord over carpeting or other heat insulators. Do not cover the cord. Keep cord away from traffic areas, and do not submerge in water. If the supply cord is damaged, it must be replaced by the manufacturer or its service agent or a similarly qualified person in order to avoid a hazard. Repair or replace immediately all electric service cords that have become frayed or otherwise damaged. Do not use a cord that shows cracks or abrasion damage along its length, the plug or the connector end.
- **WARNING:** Keep ventilation openings, in the appliance enclosure or in the built-in structure, clear of obstruction.
- **WARNING:** Do not use mechanical device or other means to accelerate the defrosting process, other than those recommended by the manufacturer.
- **WARNING:** Do not damage the refrigerant circuit.
- **WARNING:** Do not use electrical appliances inside the food storage compartments of the appliance, unless they are of the type recommended by the manufacturer.
- Do not operate your refrigerator in the presence of explosive fumes.
- **WARNING--Do not use the flame or catch the fire near the unit.**
- **DANGER-Risk of Fire or Explosion. FLAMMABLE REFRIGERANT Used. Do Not Use Mechanical Device To Defrost Refrigerator. Do Not Puncture Refrigerant Tubing**
- **DANGER-Risk of Fire or Explosion. Flammable Refrigerant Used. To Be Repaired Only By Trained Service Personnel. Do Not Puncture Refrigerant Tubing.**
- **CAUTION – Risk Of Fire Or Explosion. Flammable Refrigerant Used. Consult Repair Manual/Owner’s Guide Before Attempting To Service This Product. All Safety Precautions Must be Followed.**
- **CAUTION--Risk of Fire or Explosion. Dispose Of Property In Accordance With Federal Or Local Regulations. Flammable Refrigerant Used.**
- **CAUTION – Risk Of Fire Or Explosion Due To Puncture Of Refrigerant Tubing; Follow Handling Instructions Carefully. Flammable Refrigerant Used.**

Disposal of your unit



Warning: Risk of fire / flammable materials

Please comply with the local regulations on disposal of the appliance for its flammable refrigerant and blowing gas. Before you scrap the appliance, please take off the doors to prevent children trapped.

DANGER: Risk of child entrapment. Before you throw away your old refrigerator or freezer:

- Take off the doors.
- Leave the shelves in place so that children may not easily climb inside.

GETTING TO KNOW YOUR FREEZER

- 1) Indicating Light
- 2) Thermostat Dial
- 3) Thermostat Box
- 4) Adjustable foot
- 5) Drain port
(bottom, not shown)
- 6) Cabinet
- 7) Basket shelf
- 8) Door

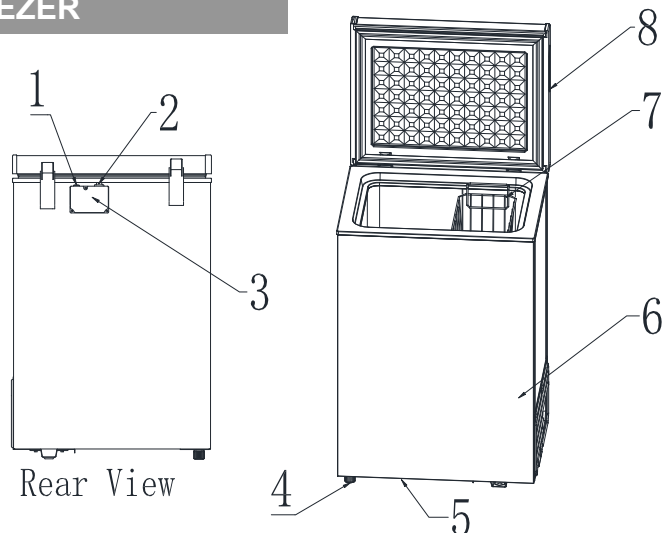

PREPARING YOUR FREEZER FOR USE

Unpacking your Freezer

- 1) Remove the exterior and interior packaging without tilting or laying it on its side.
- 2) It is advisable to clean the inside of the Freezer with lukewarm water using a mild detergent and a soft cloth, and then dry it thoroughly prior to use. **See *Cleaning Your Freezer*.**

3) **Free-standing installation only.**

Find a location for your unit that is protected from direct sunlight and other sources of heat. Place the unit on a level surface. Make sure that there is at least 5 inches of space between each side of your unit and the wall. Avoid locating the appliance in moist areas. Too much moisture in the air will cause condensation to form, requiring more frequent defrosting of the unit.

- 4) Allow it 4 hours for the refrigerant fluid to settle before plugging it in.
- 5) The refrigeration system of the cabinet is designed to operate with the cabinet located on a flat surface. Avoid tilting the cabinet side.

Connecting Your Freezer

Improper use of the grounded plug can result in the risk of electrical shock.

This unit should be properly grounded for your safety. The power cord is equipped with a three-prong plug which mates with standard three-prong wall outlets to minimize the possibility of electrical shock.

Plug your appliance into an exclusive, properly installed, grounded wall outlet. Do not under any circumstances cut or remove the third (ground) prong from the power cord. Any questions concerning power and or grounding should be directed toward a certified electrician.

This appliance requires a standard 115volt, 60Hz electrical outlet with three-prong ground. Always use ground fault protection where required by the electrical code.

Temperature Control

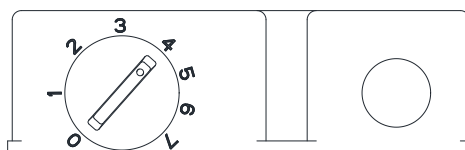

- 1) The temperature control dial is located at the back side of the cabinet.
The range of the temperature control is from position "1" the warmest to "7" the coldest. Adjust the temperature control to the setting that best suits your needs. The recommended control setting is near the No. 4 position, which should be appropriate for home or office refrigerator use.
The first time you turn the unit on, adjust the temperature control dial to "7" and run for at least 2 hours before putting food inside. This will ensure the cabinet is thoroughly chilled before food is put in.
- 2) Turning the temperature control dial to the "0" position until it clicks will switch off the power to the compressor.
IMPORTANT: Turning the control dial to the "0" position is to turn off the cooling function; It does NOT disconnect the unit from the power supply.
- 3) To adjust the thermostat control dial: turn the control to a higher number for colder temperatures, a lower number for less cold temperatures. It is recommended that you adjust by one numerical increment at a time, allowing several hours for temperatures to stabilize between increments

Cool Down Period: To ensure proper food storage, allow it 4 hours for the freezer to cool

down completely. The freezer will run continuously for the first several hours. Already frozen foods may be placed in after the first few hours of operation, however you must wait 4 hours before placing in any unfrozen food.

IMPORTANT: The storage life of frozen foods varies and the recommended storage time should not be exceeded.

Place frozen food into the freezer as quickly as possible after purchase. If there are instructions on the package, carefully follow these instructions regarding storage time.

Notes:

Do not store canned food or food stored in glass containers in the freezer compartment.

OPERATING PROCEDURES & MAINTENANCE

Moving Your Freezer

Remove all contents and make sure to tape down any loose items.

To avoid damaging the leveling screws, turn them all the way into the base.

Tape the door shut.

Make sure your unit stays in the upright position during transportation.

Defrosting Your Freezer

After you have used your freezer for some time, frost will accumulate inside mostly on the upper part of the food liner. This is due to warm, moist air entering the freezer when the door is open and it is normal. If this frost becomes thicker than 1/4", it should be removed as it will become less energy efficient due to longer running time. Under normal circumstances, defrosting will not be necessary more than once a year. To defrost your freezer properly, follow these instructions:

- 1) Unplug freezer.
- 2) Quickly remove all frozen food and store it in baskets, cartons or other suitable containers. Keep them well covered with blankets to avoid excessive temperature rise.
- 3) Place pans of hot water in the freezer with the lid open to speed melting.
- 4) Using a wooden spatula or plastic scraper, remove the frost and ice off the inner liner walls as soon as it becomes loose (approximately 15 minutes from the start)
WARNING: Do not use a mechanical device to defrost your freezer. Do not puncture refrigerant tubing.
- 5) A cloth or towel soaked in hot water will help speed up the process. Remove ice from freezer as soon as it becomes loose. Allowing it to melt will only make cleaning it more difficult.
- 6) You are now ready to clean your freezer.

Please Note: Do not pour boiling water to defrost because it may damage the plastic parts. In addition, never use a sharp or metallic instrument to remove frost as it may damage the inner liner or the cooling coils, voiding any and/or all warranties which may be in effect.

Cleaning Your Freezer

WARNING: Do not clean your freezer with flammable fluids. The fumes can create a fire hazard or explosion.

Unplug your Freezer before cleaning or making any repairs.

- 1) Turn the temperature control to "0", unplug the unit, and remove all the food and shelves.
- 2) Cleaning the Inside:
We recommend the following cleaning method: sprinkle baking soda on the sides and bottom of the freezer, this will help in cleaning and odor removal. In order to retain the finish of the freezer cabinet, inside and outside, wash painted and plastic parts only with warm water and mild soap, then rinse and dry. Do not use, under any circumstances, a gritty soap or a scouring pad as they will scratch the finish. During the defrosting operation, some water may have dripped from the back flange of the lid cover. This is quite normal. Ice has built up on the lid insulation during normal operation and this ice will melt during defrosting. You will probably have to fold over and dry the gasket on the hinge side of the lid to complete the cleaning process
- 3) Cleaning the Outside:
Wash the cabinet with warm water and mild liquid detergent. Rinse well and wipe dry with a clean soft cloth.
- 4) Wash the shelves with a mild detergent solution.
- 5) Make sure the door gasket (seal) is kept clean in order to keep the unit running efficiently

TROUBLESHOOTING

Freezer does not work	<ol style="list-style-type: none"> 1. It may not be plugged in well. 2. The circuit breaker tripped or the main fuse may be blown. 3. The thermostat may be set to "0"
The compressor turns on and off frequently	<ol style="list-style-type: none"> 1. The room temperature is hotter than usual. 2. The freezer is filled to its maximum capacity. 3. The door is opened too often. 4. The door is not closed completely. 5. The thermostat dial is set too low. 6. The door's magnetic gasket does not seal properly.
Vibrations	<ol style="list-style-type: none"> 1. The freezer may not be leveled properly.

The unit makes too much noise	<ol style="list-style-type: none"> 1. Low noise may come from the flow of the refrigerant, during the refrigeration cycle, which is normal. 2. As each cycle ends, gurgling sounds caused by the flow of refrigerant in your freezer are normal. 3. Contraction and expansion of the inside walls may cause popping and crackling noises. 4. The freezer is not level.
The door will not close properly	<ol style="list-style-type: none"> 1. The unit is not level. 2. The gasket is dirty. 3. The shelves are out of position. 4. Too much ice or frost accumulated.

TECHNICAL SPECIFICATIONS

MODEL	BD-50	BD-80
Power Supply	115V~ 60Hz	115V~ 60Hz
Rating	0.9 A	0.9 A
Capacity	50 L/1.8 Cu.Ft	78 L/2.8 Cu.Ft
Dimensions	W525*D445*H600(mm)	W525*D445*H810 (mm)
Refrigerant	R600a, 1.09 Oz/31g	R600a, 1.52 Oz/43g

Thank you for purchasing this product! If you have any questions about the product, such as missing parts, damaged products, product assembling, and operation, please contact us via **Amazon Message** or customer service number: **213-4467172 or 661-4358826**.

IMPORTANT

Please call our customer service department for any consulting:

213-4467172

661-4358826

(8:30am - 5:30pm P.S.T.)

DATED PROOF OF PURCHASE IS REQUIRED FOR WARRANTY SERVICE.

AVIS

Veillez appeler le service à la clientèle pour toutes questions au:

213-4467172

661-4358826

(8:30am - 5:30pm P.S.T.)

PREUVE D'ACHAT ORIGINALE REQUISE POUR SERVICE DE GARANTIE.

IMPORTANTE

Sólo hay que llamar nuestro departamento de servicio al cliente en caso de tener preguntas o inquietudes:

213-4467172

661-4358826

(8:30am - 5:30pm P.S.T.)

SE REQUIERE PRUEBA DE COMPRA CON FECHA PARA SERVICIO BAJO GARANTÍA.

Address: ROWAN ELECTRIC APPLIANCE LLC

28407 Ascent Way, Santa Clarita, CA 91350

Phone: 213-4467172 or 661-4358826