

NOTICE

- * Please make sure that you have all parts indicated and they are in good condition before you begin assembly of this item. Refer to part list and hardware list below for guidance.
- * This item should be assembled on a soft surface to prevent scratching the finish during assembly.
- * This item may require periodic tightening.
- * If you are having difficulty, our friendly Customer Care team is always here to help. Please email customersupport@safavieh.com







PREPARATION

- * Before beginning assembly of product, make sure all parts are present. Compare parts with part contents list and hardware contents list.
- * If any part is missing or damaged, do not attempt to assemble the product.
- * Estimated Assembly Time: 30 minutes.
- * Tools Required for Assembly (included): Allen key.

CARE AND MAINTENANCE

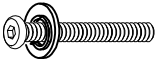
WOOD CARE: Adhesive felt pads should always be applied to areas of furniture which make direct contact with flooring, said application will prevent damage to the furniture and or surfaces on which the furniture lies. Objects placed on articles of furniture should rest on non abrasive material as to prevent damage to the wood finish. Wipe up spills immediately and avoid common hazards such as hot dishes, harsh solvents and abrasives. Cleaning should be done with a soft lint free cotton cloth dampened with water or furniture polish.

Part List and Hardware List

PIECE	DESCRIPTION	PICTURE	QTY
A	Table Top		3X
B	Leg		4X
HW1	Hex Socket Bolt 1/4"-20 x 1.5"		6X
HW2	Hex Socket Bolt 1/4"-20 x 0.625"		12X
HW3	Bracket 30 x 30 x 30mm		6X
HW4	Allen Key 4mm		1X
HW5	Anti-Tip Hardware		2X

SAFAVIEH

C O U T U R E

Model# SFV2178

Product Dimensions: 60"W x 17.5"D x 29.5"H

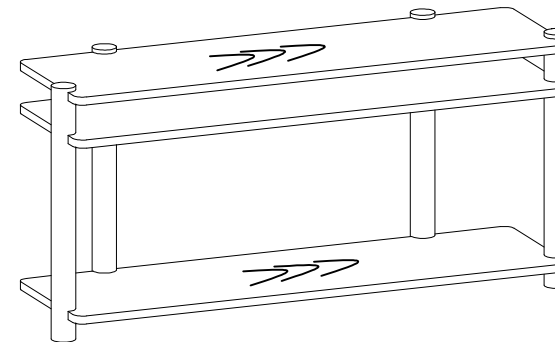

Weight capacity: 25 lbs

Warning : Do not stand on product

Warning : Do not over torque bolts

PREPARATION

- * Before beginning assembly of product, make sure all parts are present. Compare parts with part contents list and hardware contents list.
- * If any part is missing or damaged, do not attempt to assemble the product.
- * Estimated Assembly Time: 30 minutes.
- * Tools Required for Assembly (included): Allen Key.
- * If you are having difficulty, our friendly Customer Care team is always here to help. Please email customersupport@safavieh.com

1

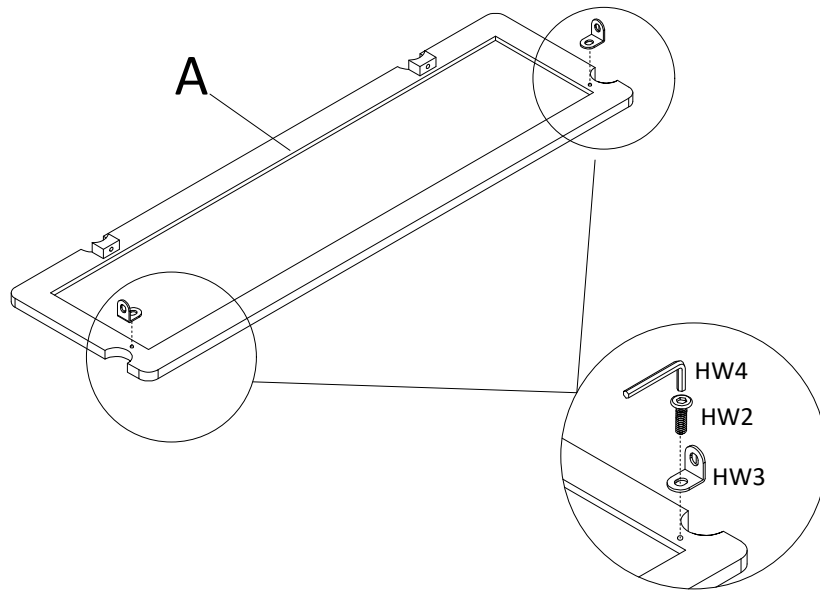

- Do not fully tighten the bolts until the product is assembled.

Step 1

Place the 3 table tops (A) upside down on a soft surface. Attach the brackets (HW3) to the back of the table tops (A) by using the Allen Key (HW4) to screw in the Hex Socket Bolts (HW2).

2

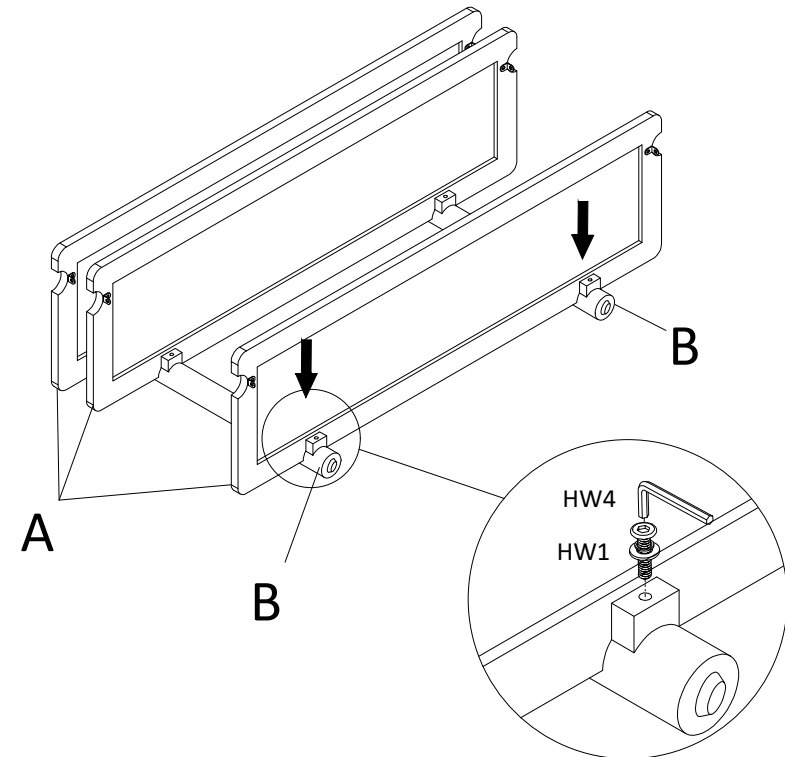

- Do not fully tighten the bolts until the product is assembled.

Step2

Align the 3 holes in the 2 back legs (B) to the holes in the wood cleats on the table tops (A). Attach the table tops to the back leg (B) by using the Allen Key (HW4) to screw in the Hex Socket Bolts (HW1).

PREPARATION

- * Before beginning assembly of product, make sure all parts are present. Compare parts with part contents list and hardware contents list.
- * If any part is missing or damaged, do not attempt to assemble the product.
- * Estimated Assembly Time: 30 minutes.
- * Tools Required for Assembly (included): Allen Key.
- * If you are having difficulty, our friendly Customer Care team is always here to help. Please email customersupport@safavieh.com

3

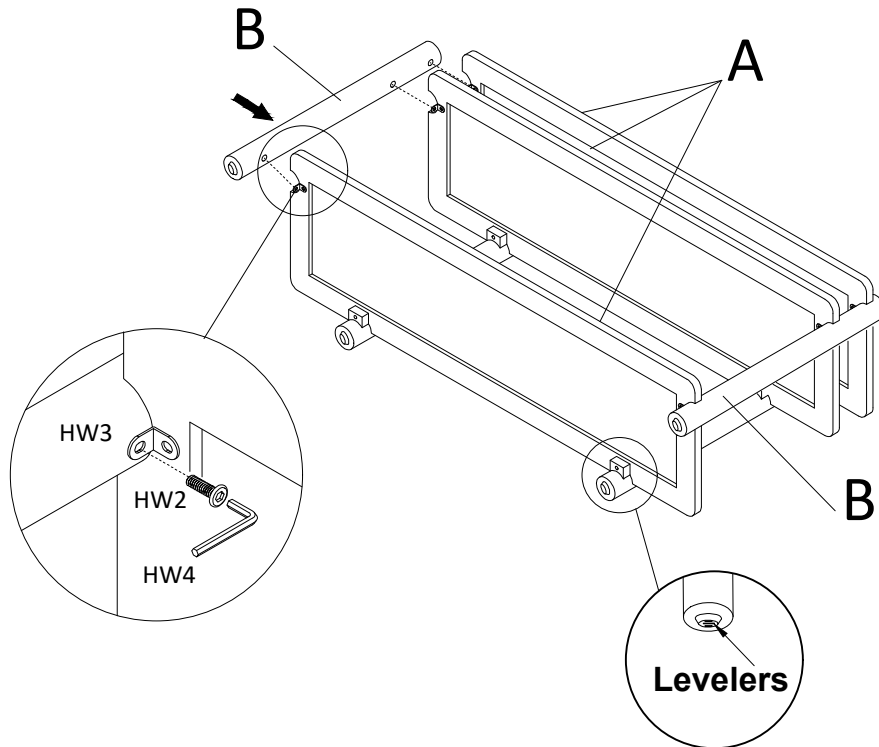

- Do not fully tighten the bolts until the product is assembled.

Step 3

Align the 3 holes on the side legs (B) to the holes on the brackets. Attach the table tops to the side legs (B) by using the Allen Key (HW4) to screw in the Hex Socket Bolts (HW2).

4

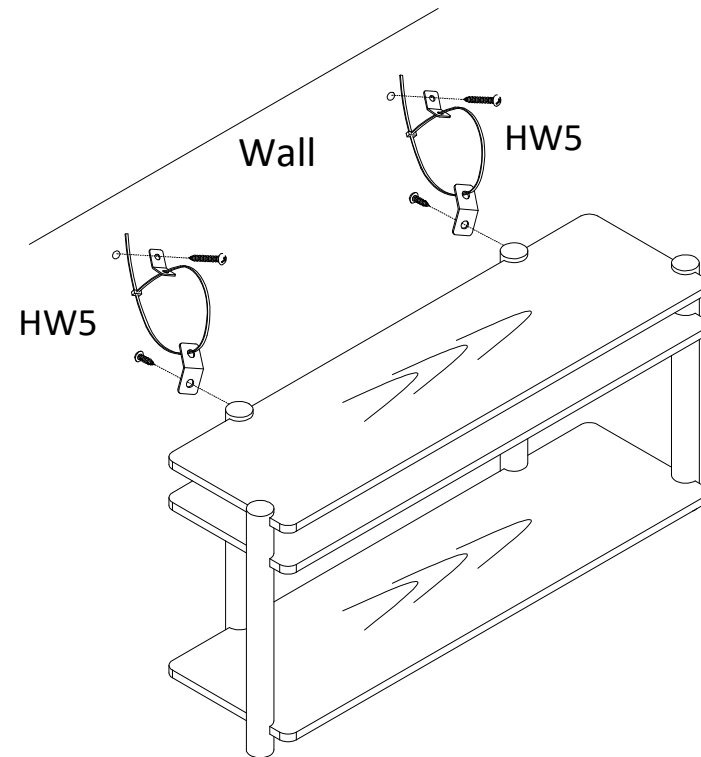

- After properly adjusting the levelers, make sure all bolts are fully tightened.

Step 4

Turn the table upright. Adjust the levelers on the bottom of the legs to make the table level if needed. Follow the installation instructions of anti-tip hardware (HW5) to attach the anti-tip kit. Assembly is now complete.