

**MANUAL DE MONTAGEM  
ASSEMBLY INSTRUCTIONS  
INSTRUCCIONES DE MONTAJE**

**COD BR: BE 841-06  
COD US: 24AMC6**



# Sumário Summary Resumen

Introdução Introduction Introducción	.....	3
Antes de começar Before starting Antes de comenzar	.....	4
Evite acidentes Avoid accidents Evitar accidentes	.....	4
Dimensões e ferramentas Dimensions and tools Dimensiones y herramientas	.....	5
Identificação das peças Identifying parts Identificación de las piezas	.....	6
Acessórios incluídos na caixa Hardware included in box Accesorios incluidos en la caja	.....	7
Montagem do móvel Furniture assembly Montaje del mueble	.....	8

## Introdução Introduction Introducción

Leia atentamente este manual e siga os passos indicados para uma perfeita montagem.  
Read this manual and follow the steps for the perfect fit.  
Lea este manual y siga los pasos para el ajuste perfecto.

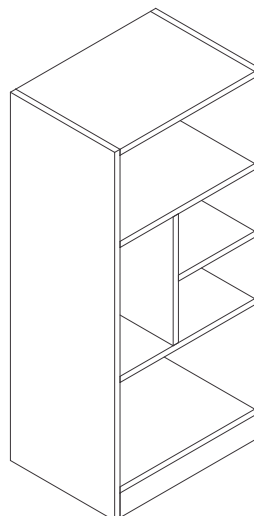

## Antes de começar Before starting Antes de comenzar

Antes de começar a montagem prepare o ambiente, deixando-o completamente limpo e com bom espaço para iniciar o trabalho.

Prepare the room before starting the assembly, leaving it completely clean and the area in good condition to start the work.

Antes de comenzar el montaje preparar el ambiente, dejándolo completamente limpio y con bueno espacio para comenzar el trabajo.

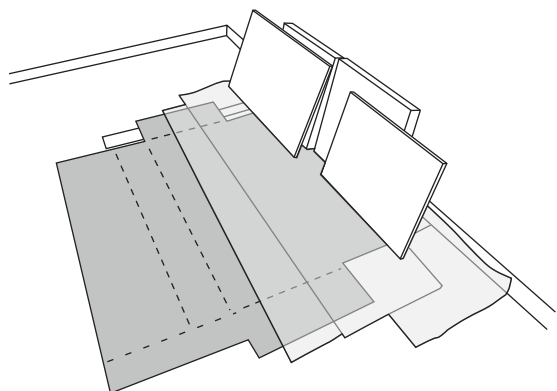

Utilize o papelão da própria embalagem para separar e apoiar as peças retiradas das caixas.

Use the cardboard of the packaging to separate and support the parts removed from the boxes.

Utilice el cartón de la embalaje para separar y apoyar las piezas desmontadas de las cajas.

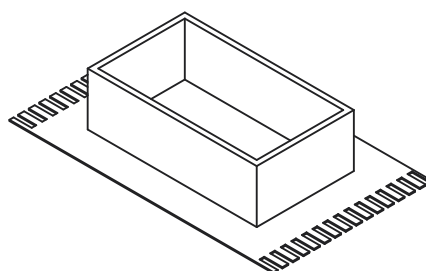

Forre a área de montagem com um cobertor ou tapete. Assim, você evita avarias nas peças durante o processo de montagem.

Cover the assembly area with a blanket or carpet to avoid damaging the parts during the assembly process.

Cubrir la zona de ensamble con una manta o alfombra. De este modo, se evitan daños en las piezas durante el proceso de montaje.



## Evite acidentes Avoid accidents Prevenir accidentes

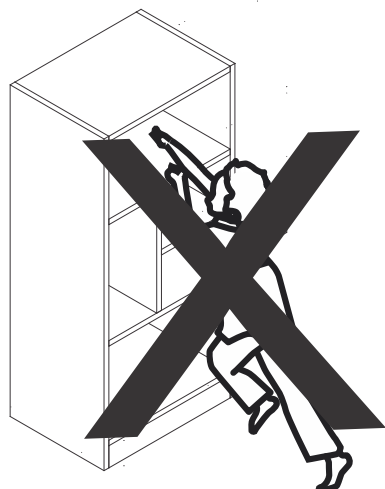

Não escale ou se apoie no móvel.

Do not climb or lean on the furniture.

No se suba ni se apoye en el mueble.

Dimensões e ferramentas  
Dimensions and tools  
Dimensiones y herramientas

Dimensões:

L: 410 A: 905 P: 294 mm

Dimensions:

W: 16.14 H: 35.43 D: 11.57 inches

Dimensiones:

L: 410 A: 905 P: 294 mm

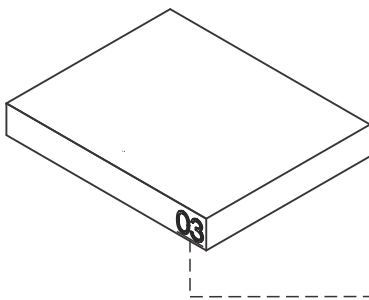
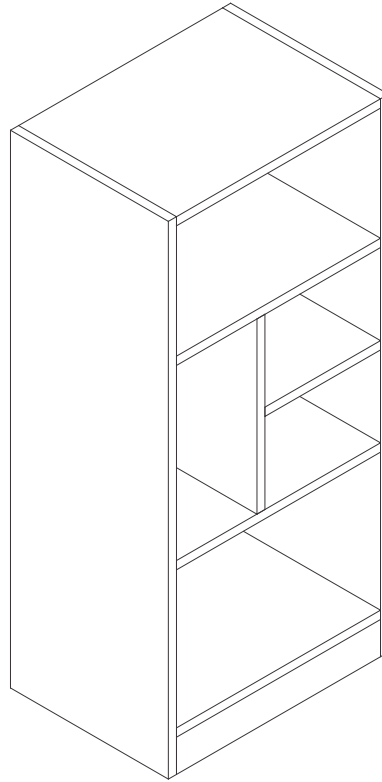

**UTILIZE ALCOOL PARA REMOVER O NUMERO DAS PEÇAS**  
**USE ALCOHOL TO REMOVE PART NUMBERS**  
**UTILICE ALCOHOL PARA ELIMINAR EL NUMERO DE LAS PIEZAS**

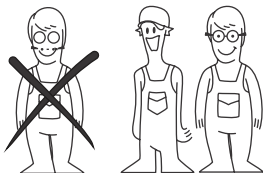

Para facilitar a montagem, utilize uma parafusadeira elétrica.  
To improve assembly, use an electronic screwdriver.  
Para facilitar el armado, utilice un destornillador eléctrico.

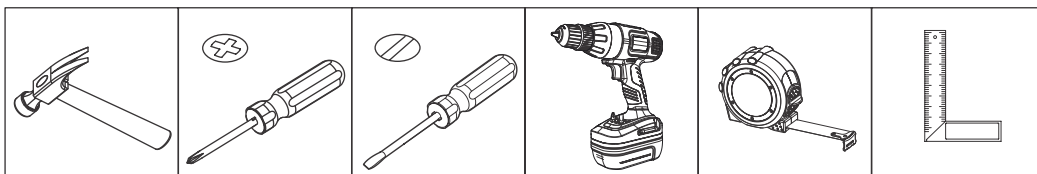

COD BR: BE 841-06  
 COD US: 24AMC6

PEÇA	DESCRIÇÃO	QUANT.
001	LATERAL ESQUERDA	1
002	TAMPO/BASE	2
003	PRATELEIRA	2
004	DIVISÓRIA MAIOR	1
005	PRATELEIRA MENOR	1
006	RODAPÉ	1
007	LATERAL DIREITA	1
008	COSTA	1

PART	DESCRIPTION	QTY
001	LEFT SIDE	1
002	TOP/BASE	2
003	SHELF	2
004	LONGER PARTITION	1
005	LOWER SHELF	1
006	BASEBOARD	1
007	RIGHT SIDE	1
008	BACK	1

PIEZA	DESCRIPCIÓN	CANTIDAD
001	LATERAL IZQUIERDA	1
002	TAPA/BASE	2
003	REPISA	2
004	PARTICIÓN MAYOR	1
005	REPISA MENOR	1
006	RODAPÍE	1
007	LATERAL DERECHA	1
008	REVÉS	1

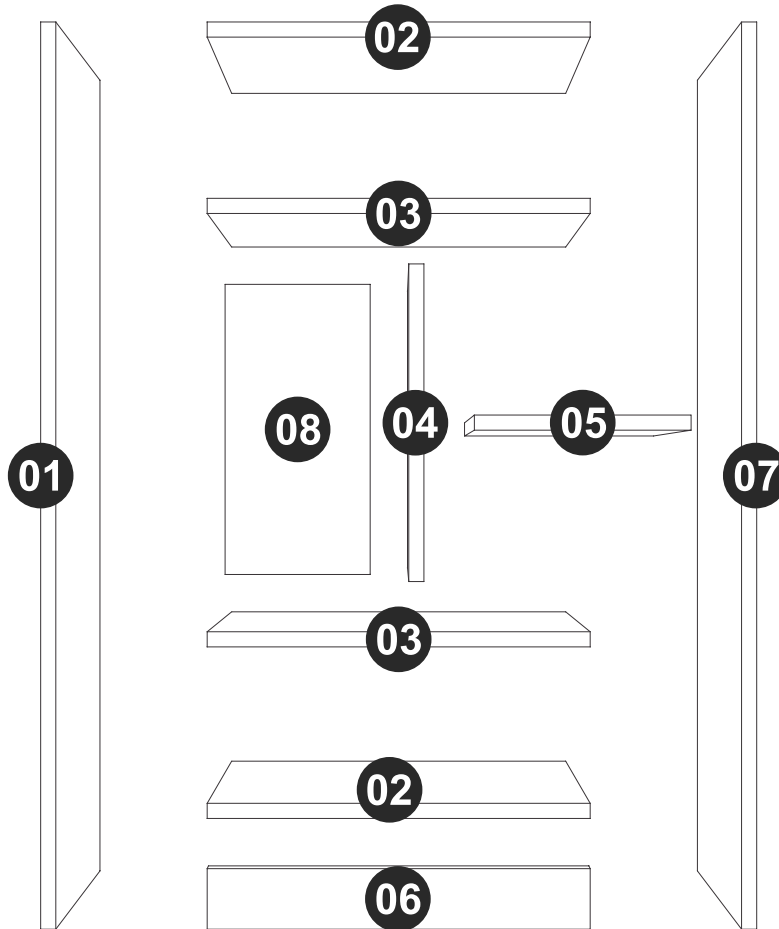



EF 000106 x 8



PÉS REDONDOS x 04  
ROUND FEET x 04  
PIES REDONDOS x 04

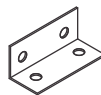

EF 000061 X 02



EF 000033x 24



TAPA-FUROS x 16  
STICKER x 16  
TAPAS PLÁSTICAS x 16



EF 000132 x 16



EF 000168 X 15



GIZ x 01  
CHALK x 01  
TIZA x 01

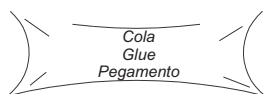

EF 000008 X 1

**A** = 5 KG - 11LB

**B** = 3KG - 6.61LB

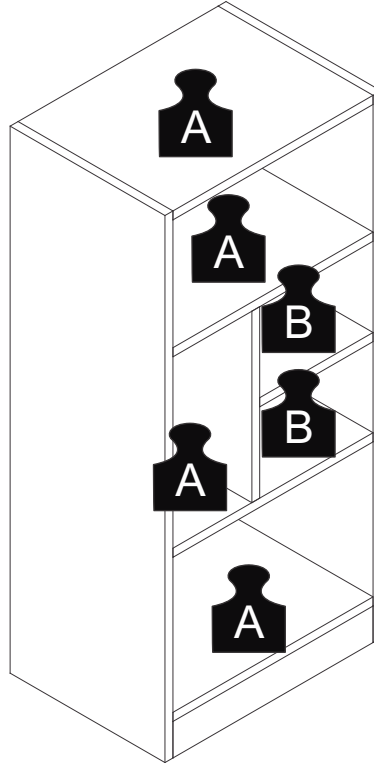

### PASSO 1 / STEP 1 / PASO 1

Utilize a cola (EF 000008) antes de inserir a ferragem EF 000033 nas peças 02, 03, 04 e 05.

Use the glue (EF 000008) before connecting hardware EF 000033 into pieces 02, 03, 04 and 05.

Utilice el pegamento (EF 000008) antes de añadir el herraje EF000033 en las piezas 02, 03, 04 y 05.

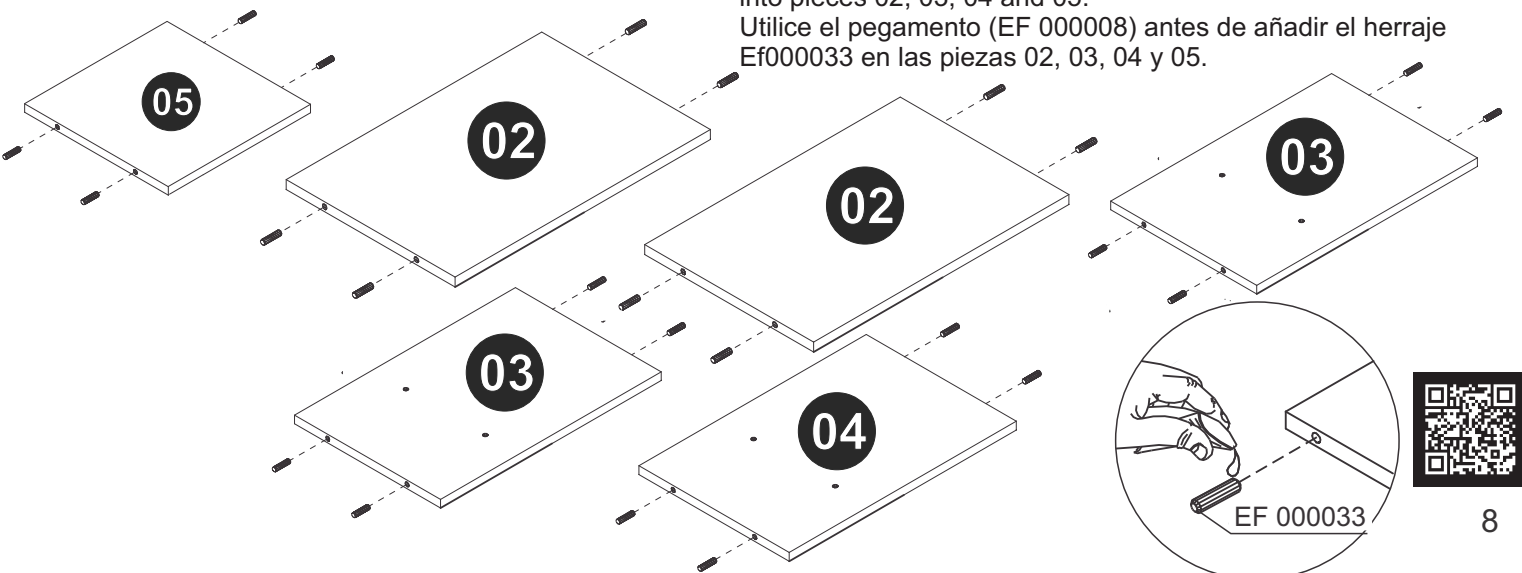

## PASSO 2 / STEP 2 / PASO 2

Utilize a cola (EF 000008) antes de conectar as peças 03 e 04.  
Use the glue (EF 000008) before connecting pieces 03 and 04.  
Utilice el pegamento (EF 000008) antes de juntar las piezas 03 y 04.

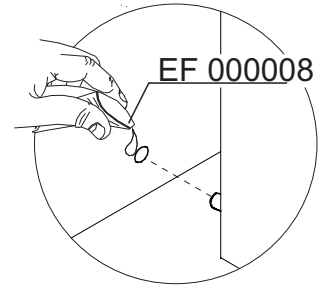
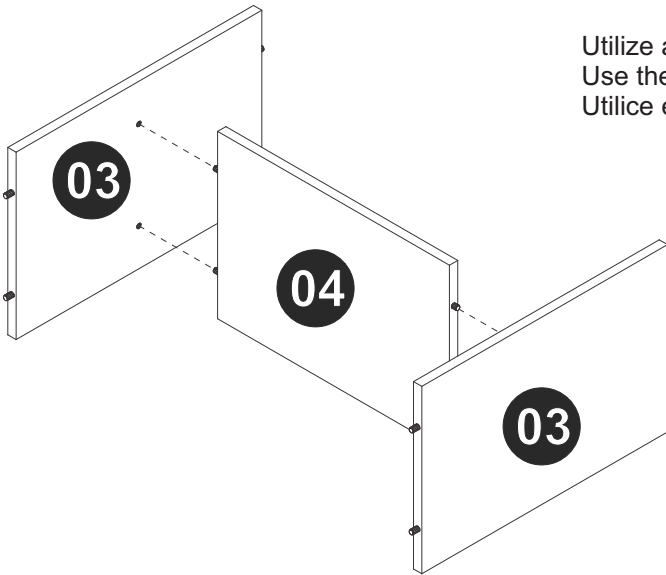

## PASSO 3 / STEP 3 / PASO 3

Utilize a cola (EF 000008) antes de conectar a peça 05 a parte montada no passo anterior.  
Use the glue (EF 000008) before connecting piece 05 to part assembled in the previous step.  
Utilice el pegamento (EF 000008) antes de juntar la pieza 05 a la parte armada en el paso anterior.

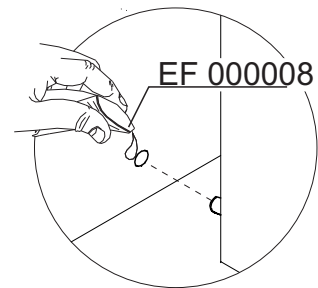
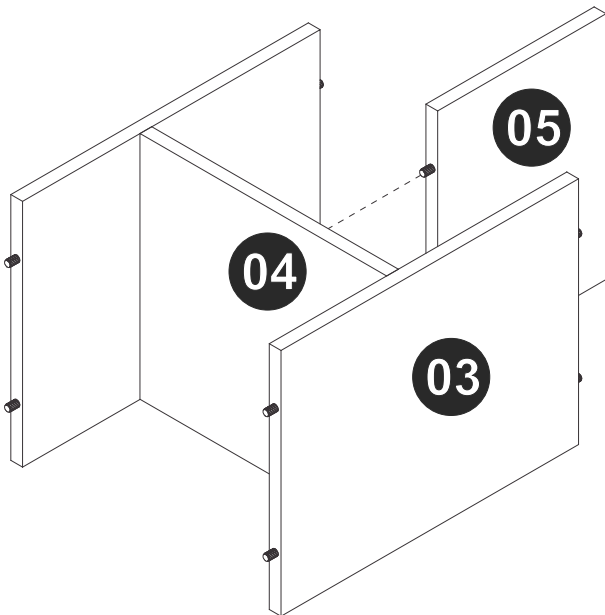

## PASSO 4 / STEP 4 / PASO 4

Para conectar a peça 06 a peça 02, use a ferragem EF 000061 e EF 000106.  
To connect piece 06 at piece 02, use hardware EF 000061 and EF 000106.  
Para juntar la pieza 06 a pieza 02 utilice el herraje EF 000061 y EF 000106.

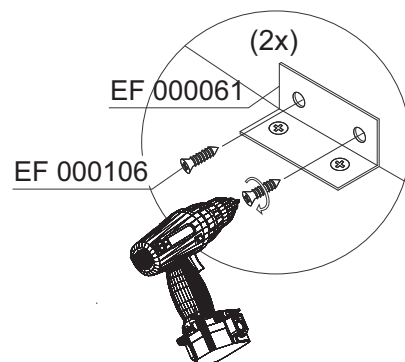
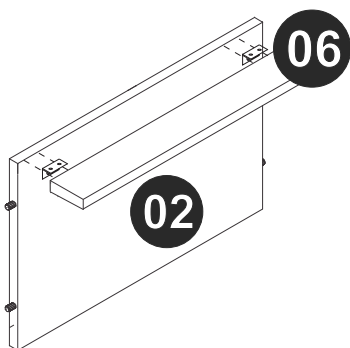

### PASSO 5 / STEP 5 / PASO 5

Conectar as peças 01, 02 e 07 as partes montadas nos passos 3 e 4 utilizando a ferragem EF 000132.  
Connect pieces 01,02 and 07 to parts assembled in the steps 3 and 4 using hardware EF 000132.  
Junte las piezas 01, 02 y 07 a las partes armadas en los pasos 3 y 4 utilizando el herraje EF 000132.

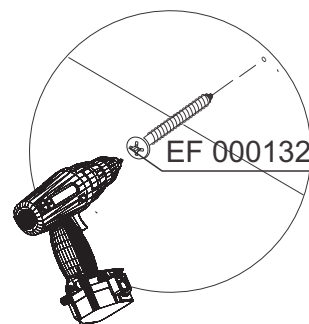
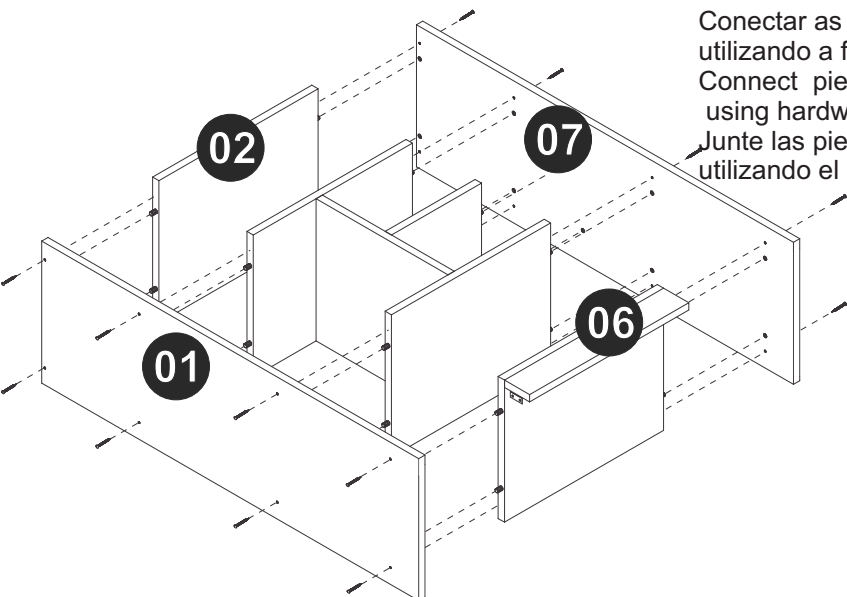

### PASSO 6 / STEP 6 / PASO 6

Fixe a peça 08 ao móvel utilizando a ferragem EF 000168.  
Fix piece 08 at the furniture using hardware EF 000168.  
Fije la pieza 08 al mueble utilizando el herraje EF 000168.

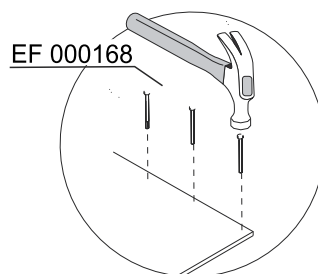
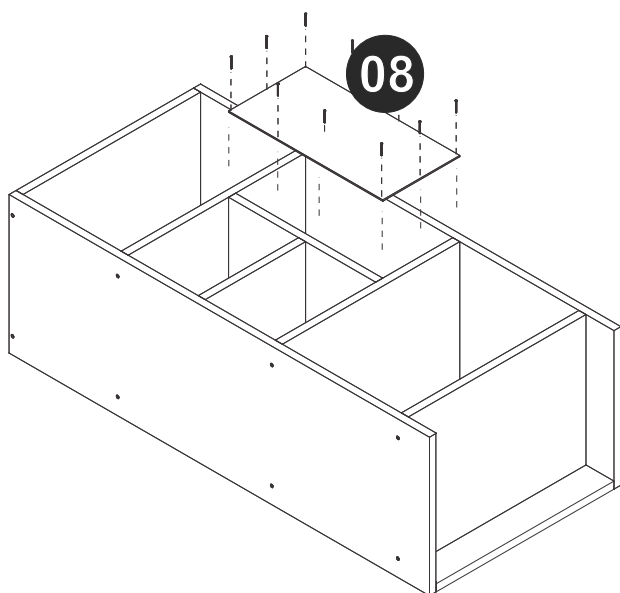

### PASSO 7 / STEP 7 / PASO 7

Fixe os pés redondos utilizando a ferragem EF 000168 de acordo com a imagem.  
Fix the round feet using hardware EF 000168 according to the image.  
Fije los pies redondos utilizando el herraje EF 000168 de acuerdo con la imagen

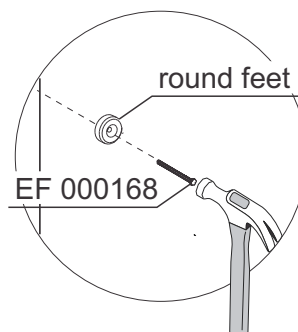
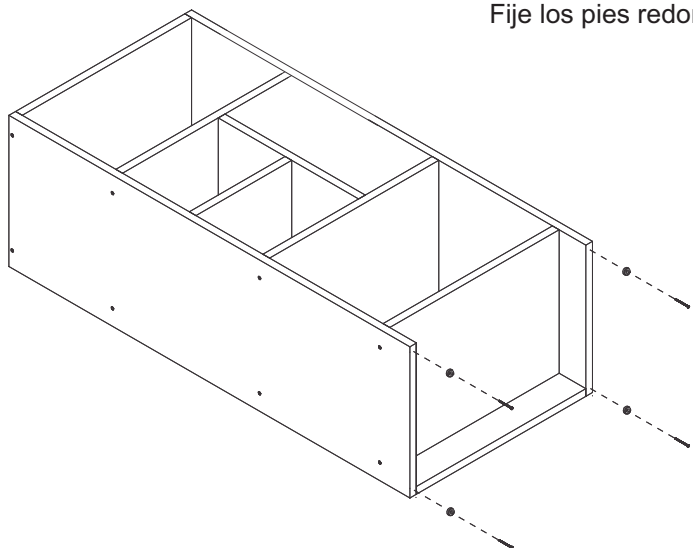

### PASSO 8 / STEP 8/ PASO 8

Utilize o tapa furos para cobrir os parafusos aparentes.  
Utilize o giz para dar o acabamento final ao produto.  
Use the sticker to cover the apparent screws.  
Use the chalk to give the final finish on the product.  
Utilice los tapa huecos para cubrir los tornillo aparentes.  
Utilize la tiza para dar el acabado final al producto.

