

TRAMPOLINE

WITH ENCLOSURE NET

U S E R M A N U A L

INSTALLATION WARNING

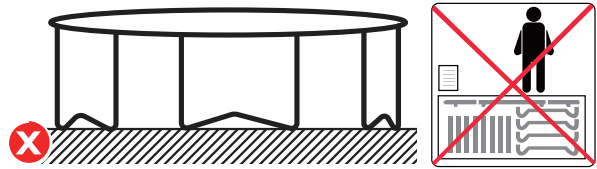
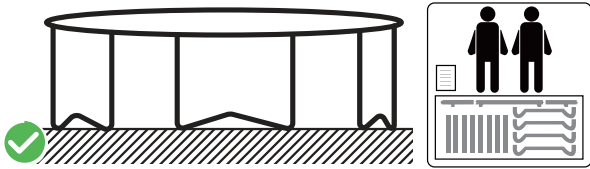

1. Please make sure at least 2 people install the trampoline.

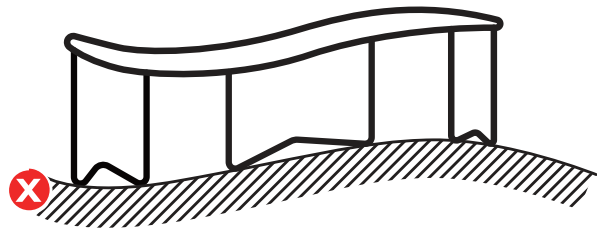
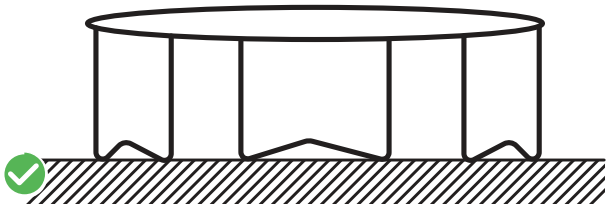

2. Please install the trampoline on the flat and non-slippery ground.

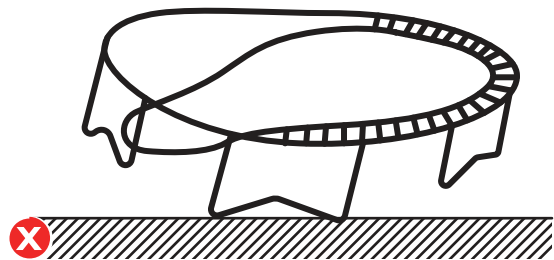
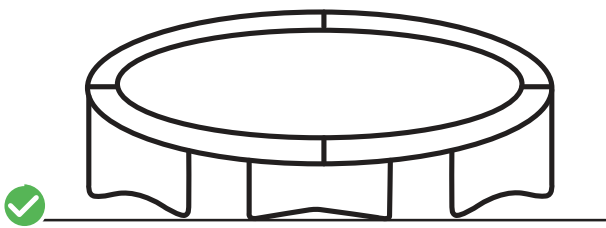

3. Please install the springs in the X-shape order one by one as requested in the instructions.

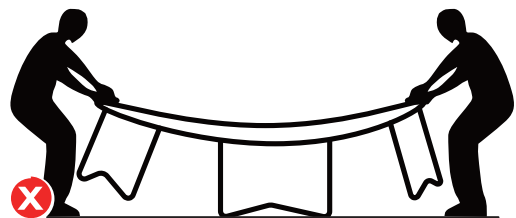
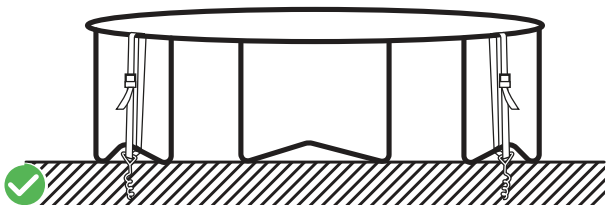

4. Please do not move or lift the trampoline during or after installation but use the tie down stakes kit to secure it.

USE WARNING



Do not somersault or flip.



Do not dunk and hold onto the ring.



Do not jump onto the trampoline from a height.



Do not intentionally hit the safety enclosure net.



Do not use the trampoline in stormy weather but disassemble and store it.

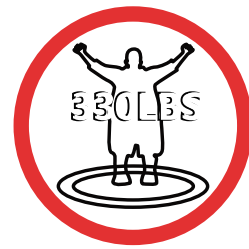

Do not exceed 330lbs for a single user and do not exceed the total weight for multiple users.















Do not place any sharp objects on the trampoline.



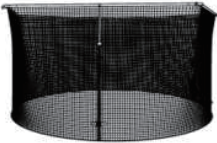

Do not use during pregnancy, high blood pressure or other injuries.

ADDITIONAL SAFETY WARNING

- Read all instructions before using the trampoline.
- Use trampoline only under adult supervision.
- Not recommended for children under six years old.
- Secure the trampoline against unauthorized use.
- Use only when the jumping mat is clean and dry.
- Do not use the trampoline without the spring cover pad.
- Do not use the trampoline while under the influence of alcohol or drugs.
- Do not smoke while using the trampoline.
- Do not use the trampoline as a spring board to jump onto other objects. Do not jump from other buildings or object surfaces, onto the trampoline or into or over the trampoline enclosure.
- Never set up or continue to use the trampoline in heavy rain, wind, or storm weather, especially lightning storms. It's recommended that disassemble and store the trampoline in bad weather.
- Inspect carefully before using and replace any worn, defective or missing parts.
- Avoid bouncing too high. Maintain control. Do not try to jump over the enclosure.
- Do not jump and try to hang onto the top of the netting or the enclosure pole.
- Don't intentionally kick, bounce against, climb on, hang from, jump over or crawl under the enclosure.
- Wear clothing free of drawstrings, hooks, loops, or anything that could get caught in the enclosure.
- Enter and exit the enclosure only through the zipper door. Do not crawl under the trampoline. Do not go through the gap between the enclosure and the mat.
- Misuse of the enclosure may result in serious injury or death.
- Users may become entangled in or strangled by loose cords or in gaps between trampoline and enclosure.
- Keep the enclosure tightly fastened to the trampoline in accordance with the manufacturer's instructions.
- Failure to properly assemble and maintain a tight, secure trampoline/enclosure boundary may result in serious injury, strangulation or death.

NO	PART	NAME	QTy
1		Top Rail	10
2		T-shaped Connector	10
3		Leg Extension (two holes)	5
4		Leg Extension	5
5		Base Leg	5
6		Upper pole B	5
7		Upper pole A	5
8		Frame Pad	1
9		Safety Net	1
10		Net Rope	8
11	 M6*75	Bolt Pack (M6*75)	10
12		Spring	80
13		Jumping Mat	1

14		Spring Tool	1
15	 M6	Wrench	1

Step 1

Attach the Top Rail (#1) to the T-shaped Connector (#2) until you form the circle. As shown in Fig. (You can use great force if it is too tight)

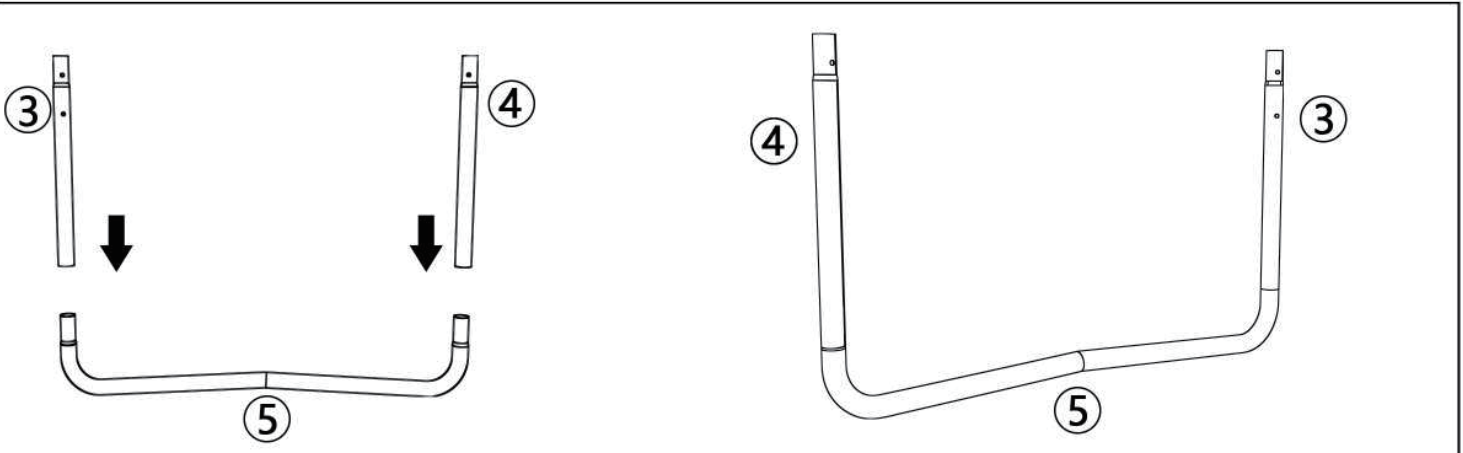
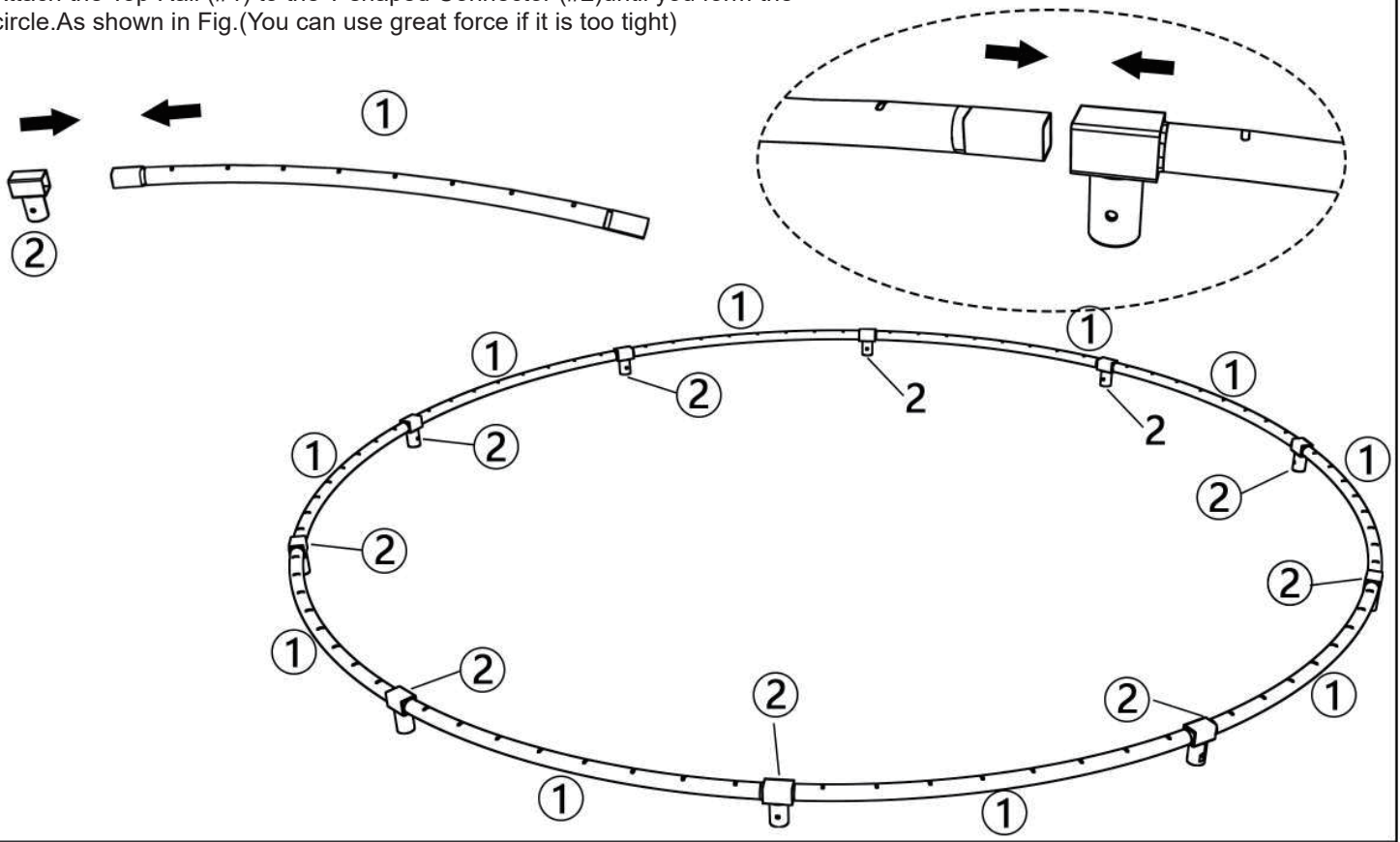

Step 2

Insert the Leg Extension (#3) with the Leg Extension (#4) into the Base Leg (#5) and stick out completely, totally 5 legs. As shown in Fig.

Step 3

Two people will be necessary at this point to install the trampoline. One person lifts up the circle frame, while the other lifts the W-shaped leg tubes to a standing position and inserts the T-shaped Connector (#4) into a W-shaped leg tube. Ensure the locking holes are aligned. As shown in Fig.

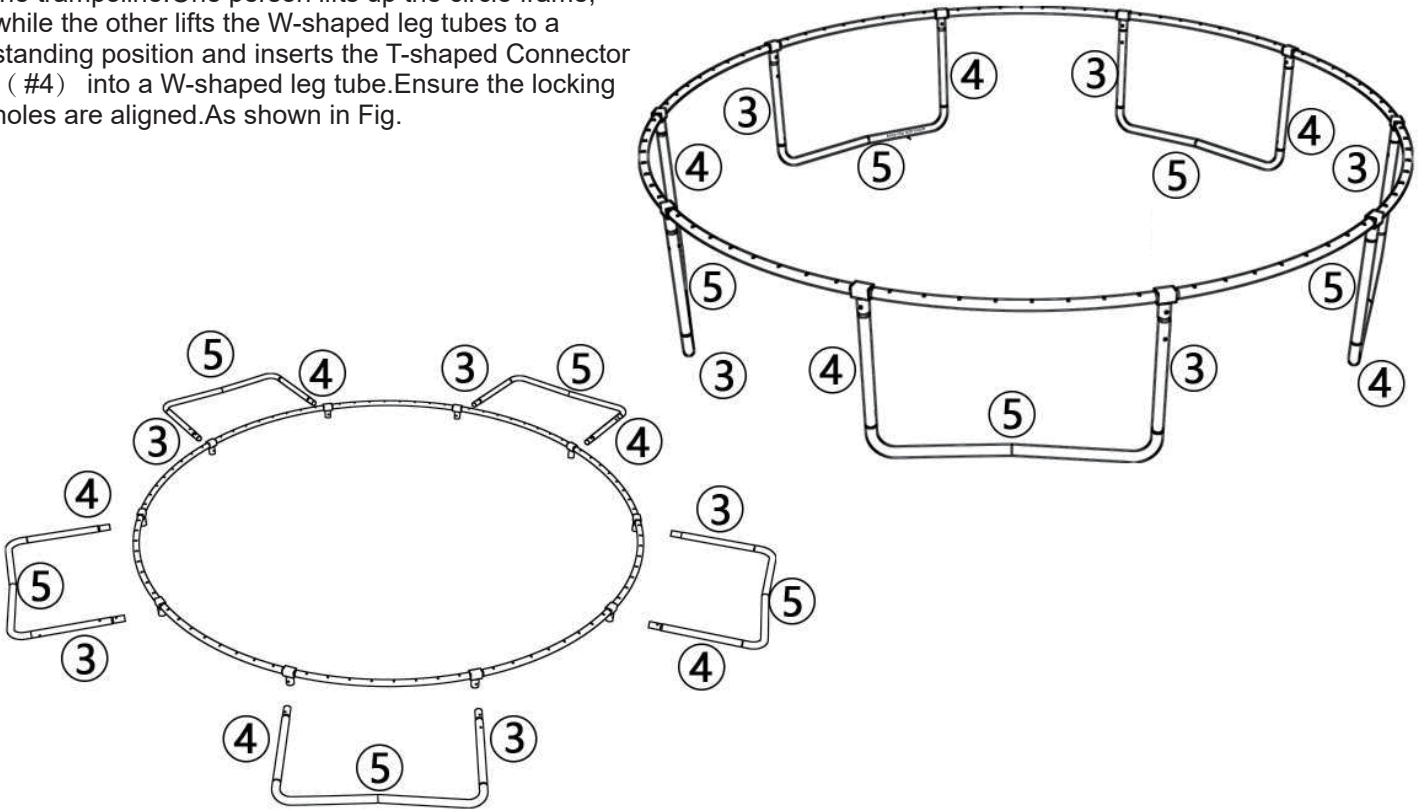

Step 4

Layout the Jumping Mat (#13) inside the circle frame.

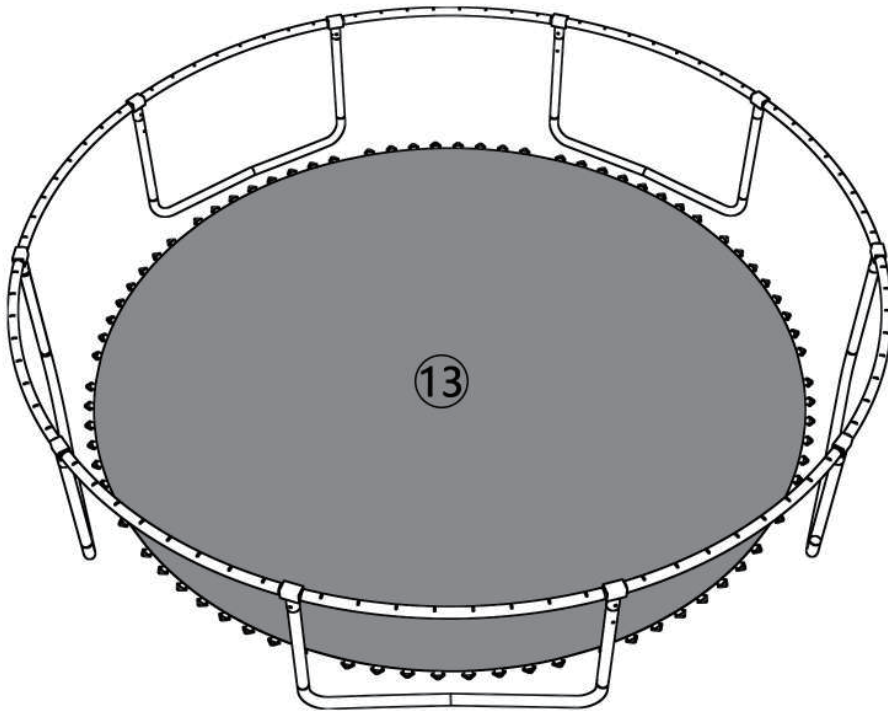

Step 5

Install the Springs(#12) in the X-shape order one by one to make sure the tension is distributed evenly for the Jumping Mat(#13) and pull it with Spring tool(#14).As shown in Fig.(Tip: Please take care not to pinch your hands and other body parts during spring assembly.)

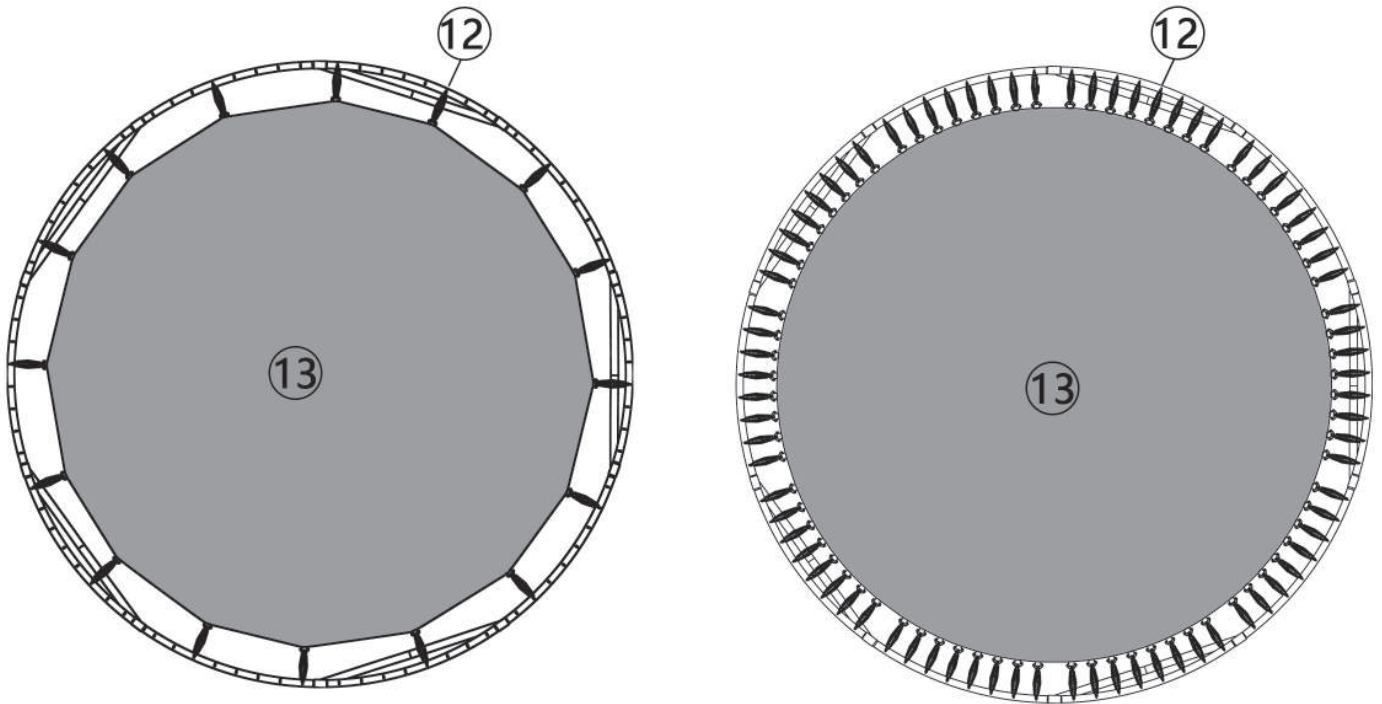
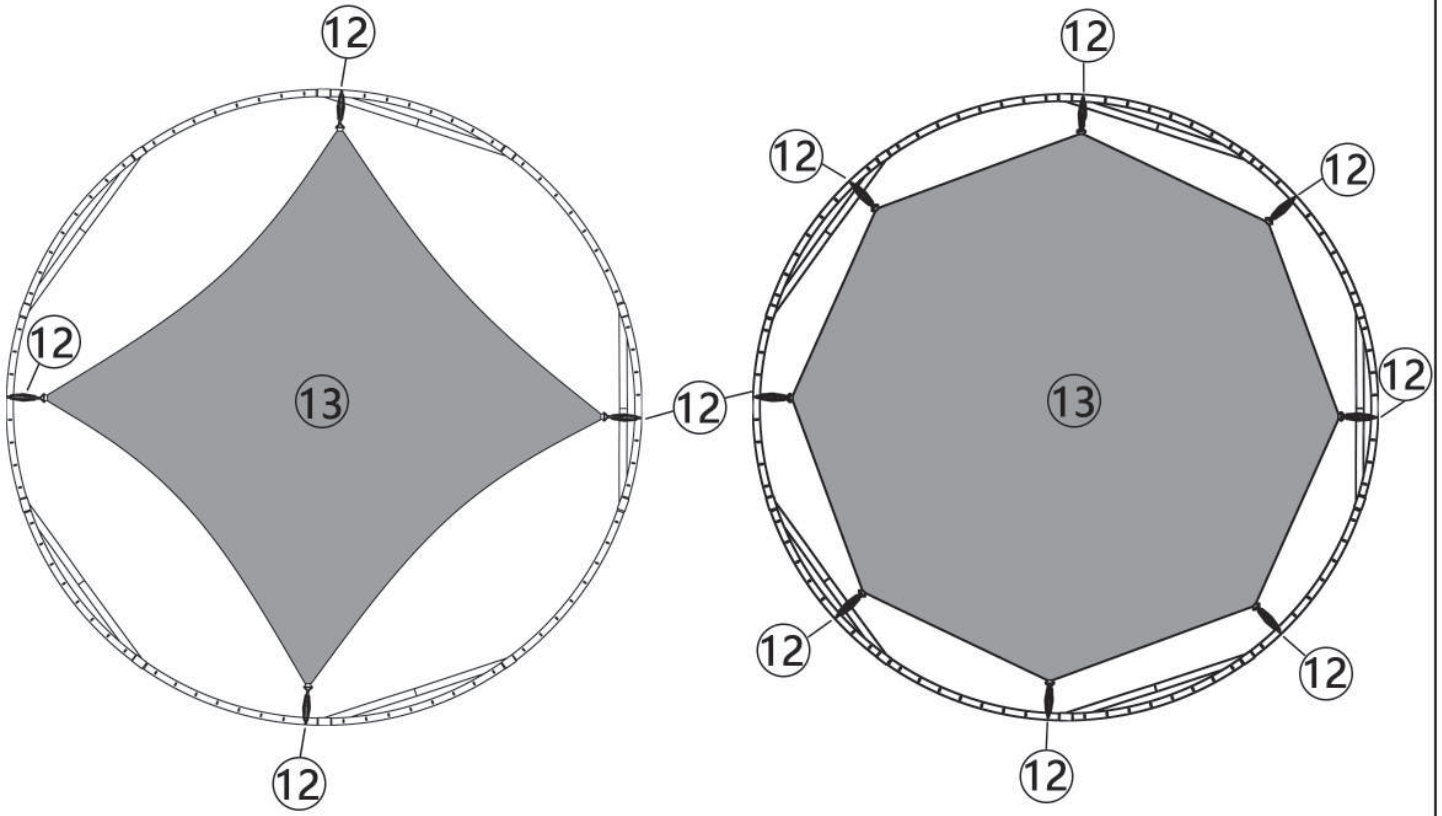

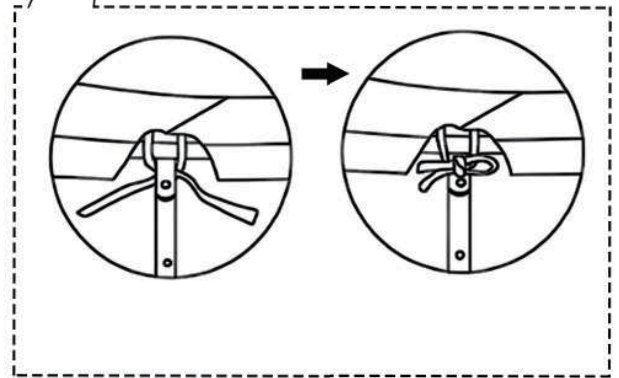
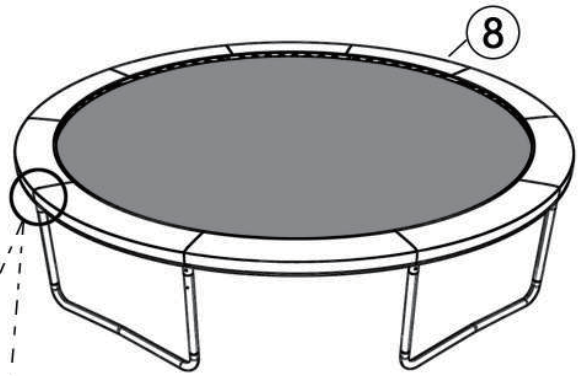
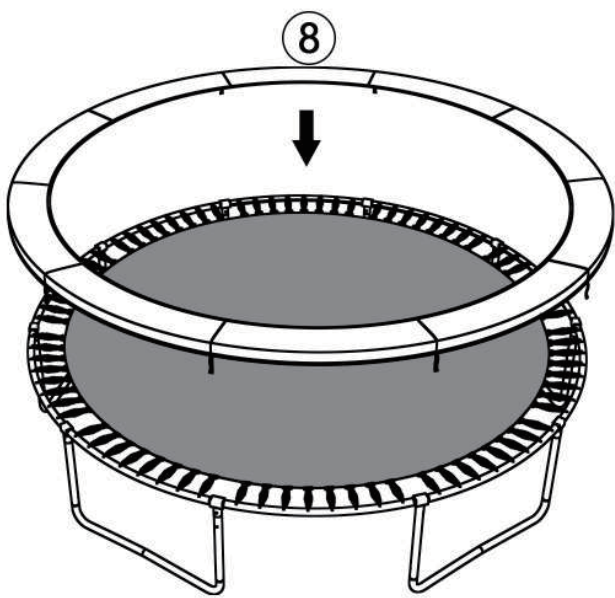

Step 6

Please lay the frame cover pad (#8) over the springs;
Tie the strap located at the under side of the frame pad to
the frame. As shown in fig.

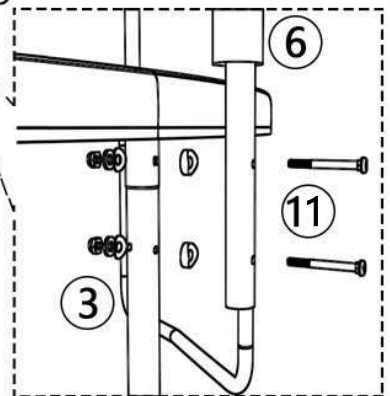
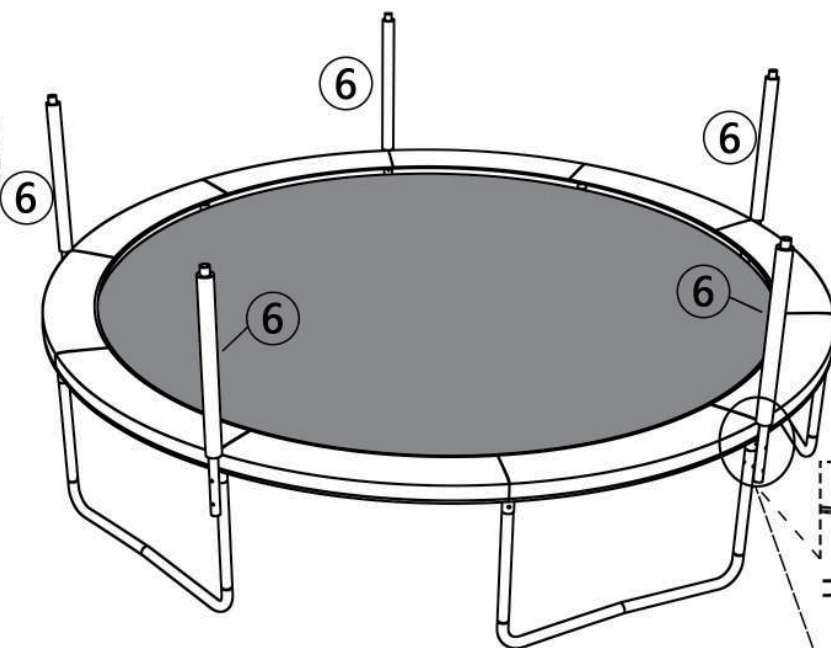
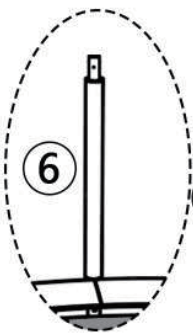

Step 7

The Upper Pole B (#6) is locked and fixed in the two holes at
the upper end of Leg Extension (#3) with screw (#11). As shown in fig.

Step 8

Please insert the Upper Pole A (#7) into the Upper Pole B (#6). As shown in fig.

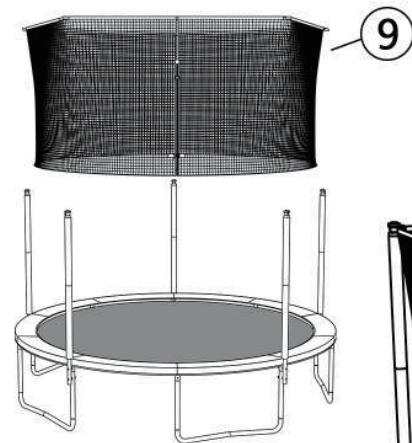
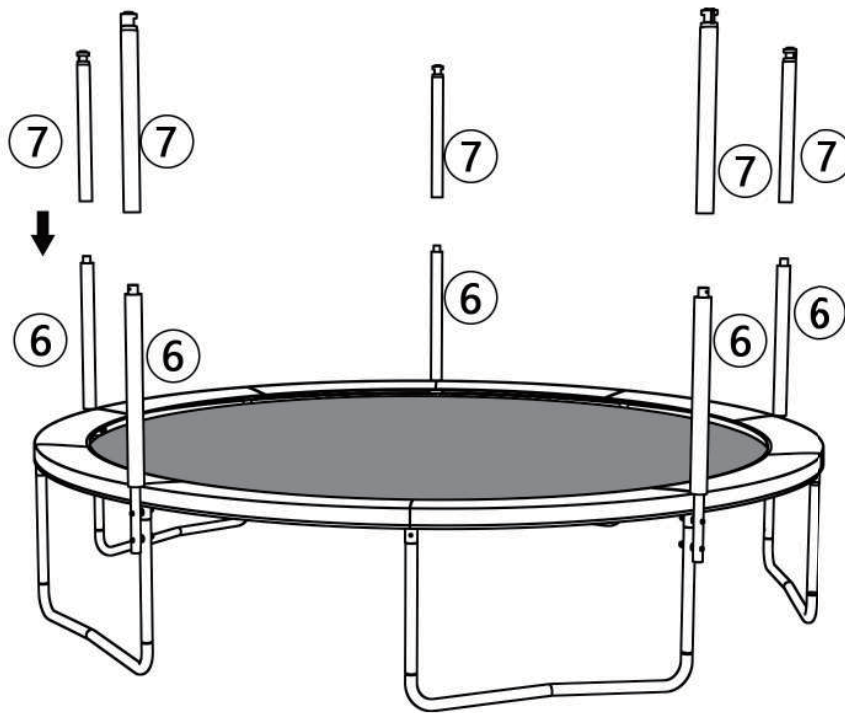

Step 9

Spread Safety Net (#9) out on the trampoline mat. Pass the strap through the ring of the Upper Pole Cap (#7), along the Upper Pole Cap (#7), and through the buckle, and lock the buckle. As shown in fig.

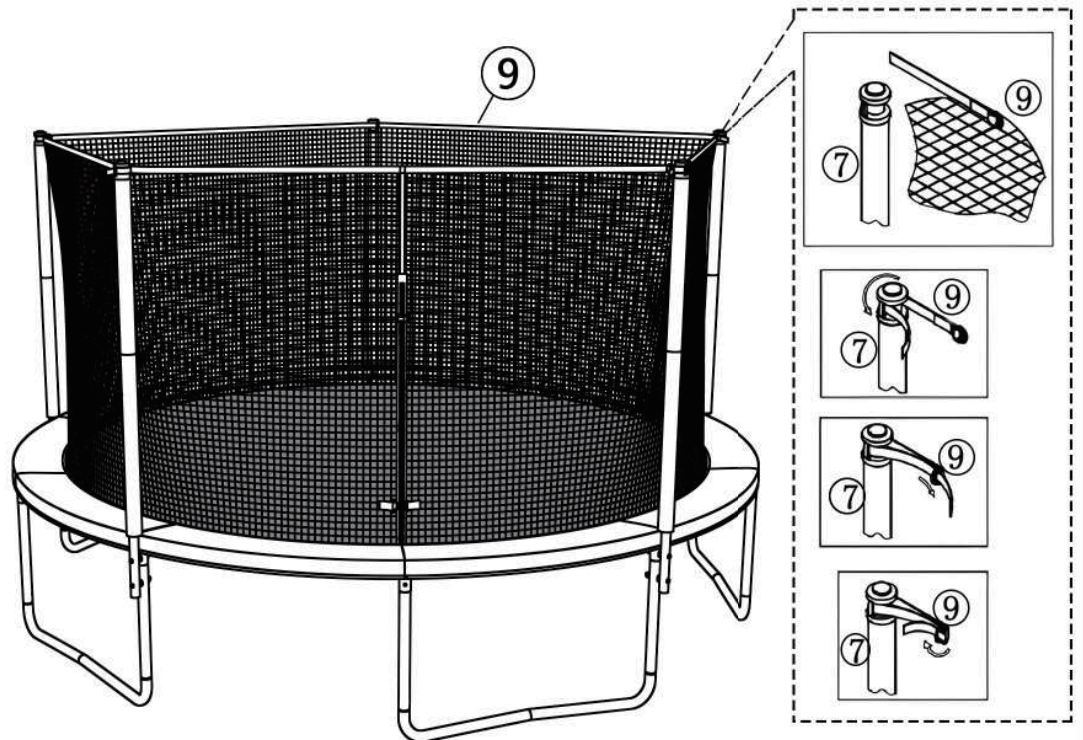

Step 10

Components Net Ropes (#10), Safety Net (#9) through the bottom hole components, and parts cross around spring, and fixed. As shown in fig.

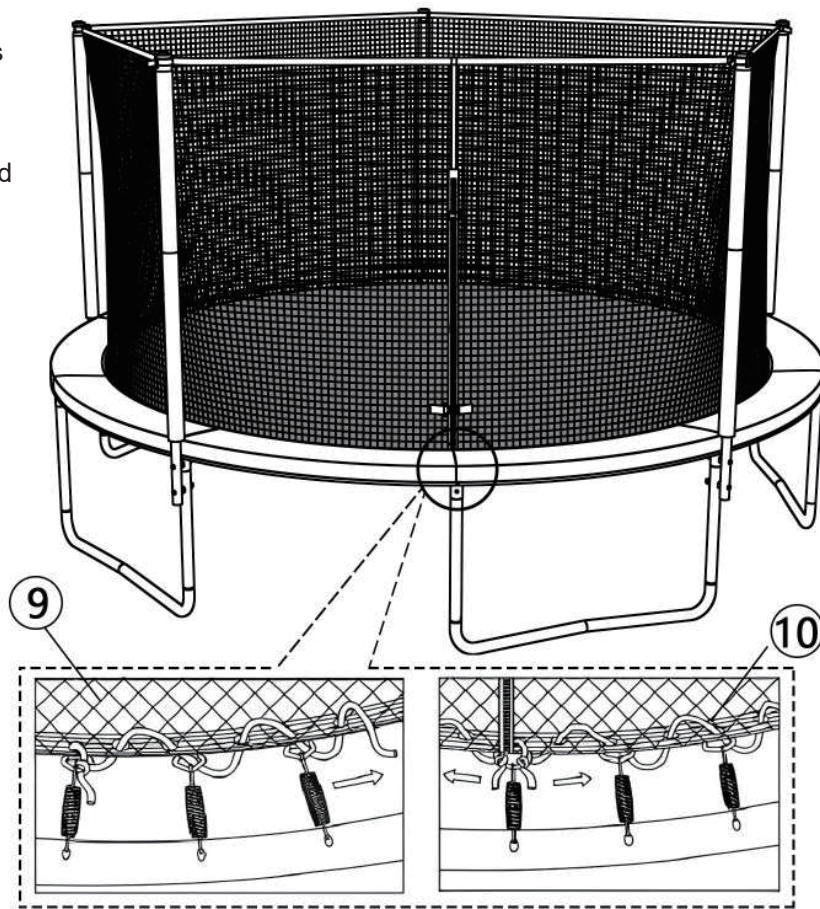

USER MANUAL FOR LADDER (2 STEP/ 3 STEP)

WARNING & INSTRUCTION

- Please read the assembly instructions before beginning to assemble the product.
- Please refer to the table for part descriptions and numbers. The assembly instruction use these descriptions and numbers as reference.
- Make sure you have all parts listed. If you are missing any parts, please contact place of purchase.
- Only assemble by adult.

LADDER PART LIST

Ref.number	Part. number	Description	Unit (pcs)
1	LD001	Frame poles	2
2	LD002	Step poles	2 or 3
3	LD003	Screws	4 or 6
4	LD004	Manual	1

LADDER ASSEMBLY

Step 1. Frame install

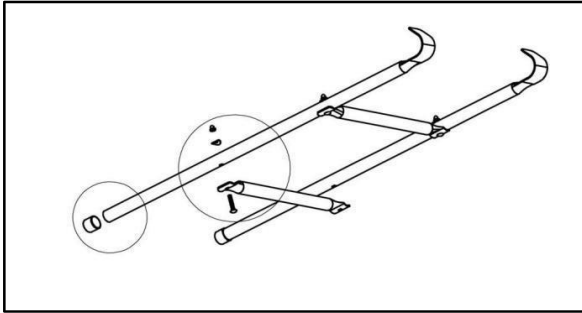

Layout all of the parts as pictures. select two frame pole which have two or three holes.

Step 2 Install screws

Pls install all of the screws use toolas show.

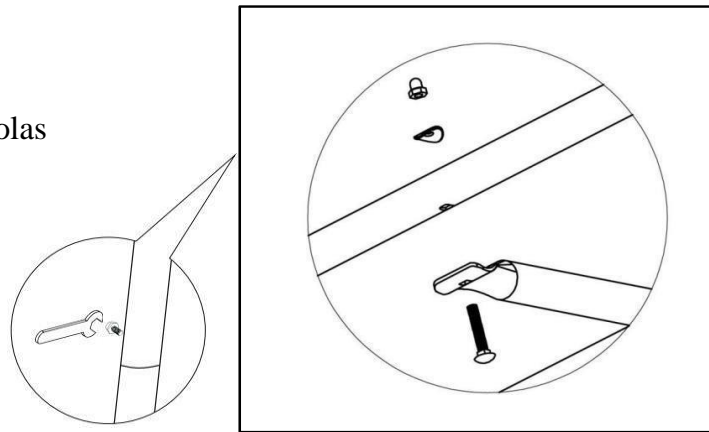

Step 3. Install Finished

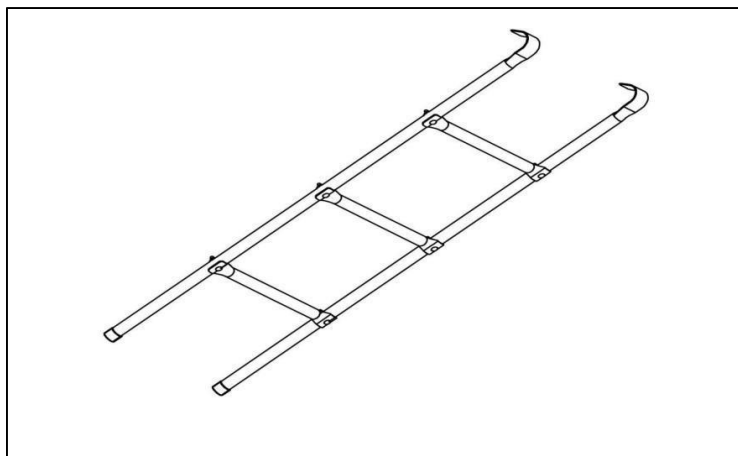



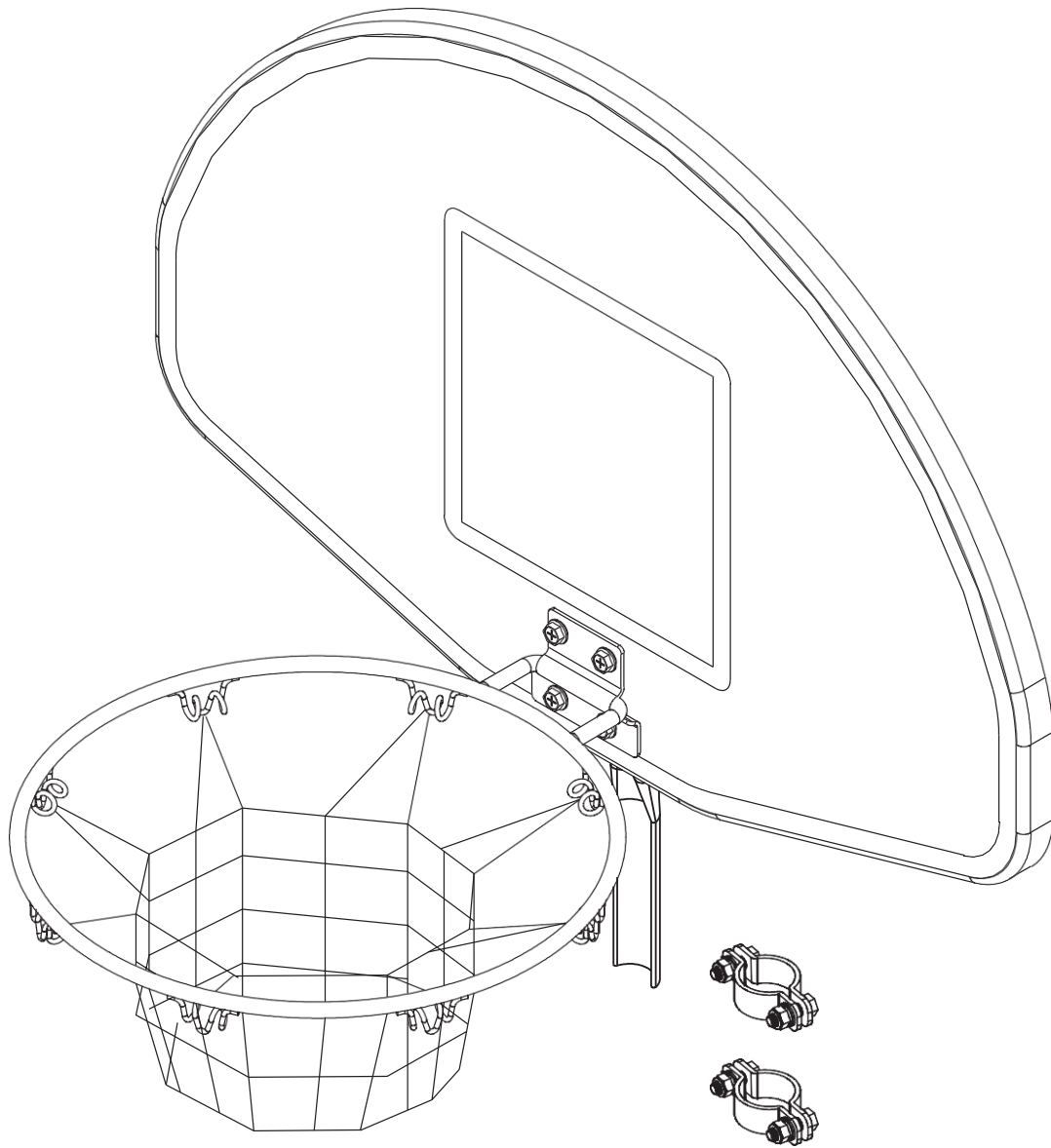





BASKETBALL HOOP INSTALLATION MANUAL

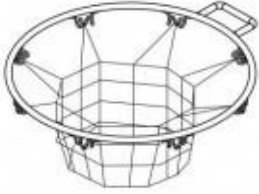
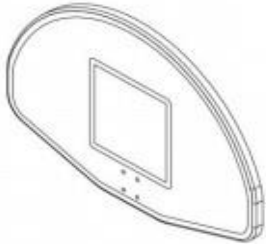
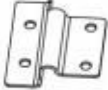

WARNING

- * Read and follow this installation manual
- * Adult assembly required

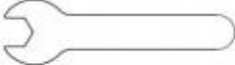
PARTS LIST

 A 1PC	 B 1PC	 C 1PC	 D 1PC
 E (M6×28) 4PCS	 F (M6×20) 2PCS	 G 1PC	 H 1PC
 I 2PC	 J 1PC	 K 1PC	

ASSEMBLY

Step 1 : Connect A and B with C, D and E

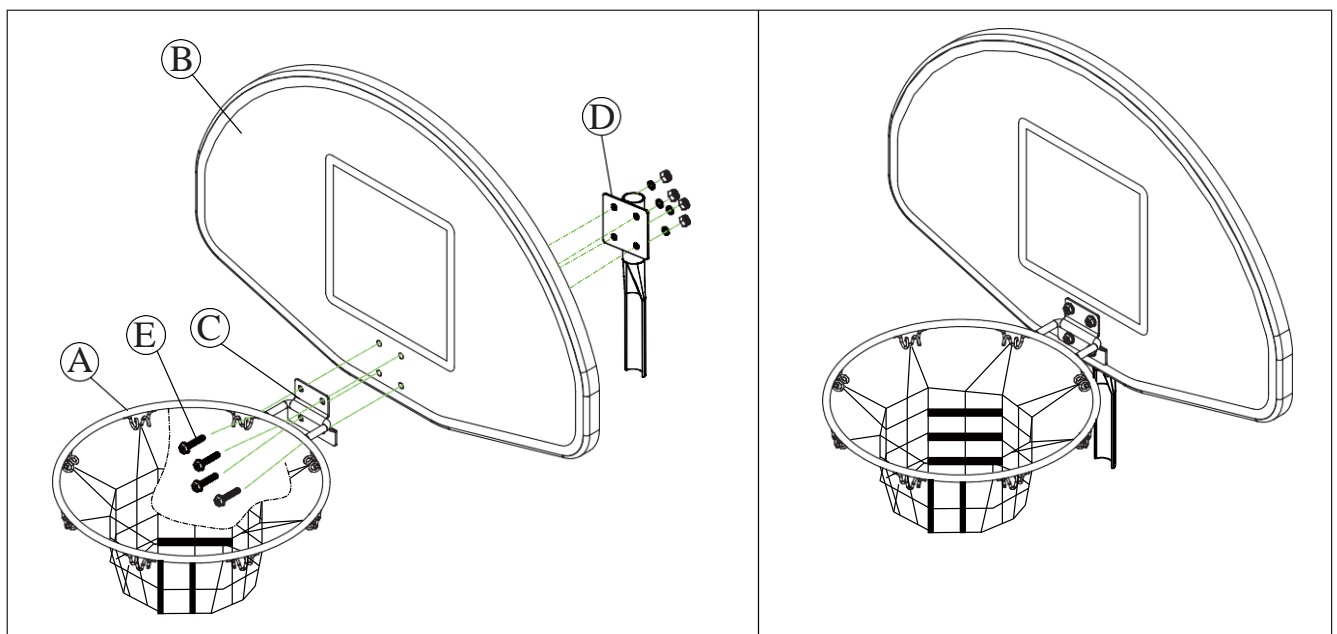

Step 2: Select an upper pole A to remove the cap, then install a flat cap

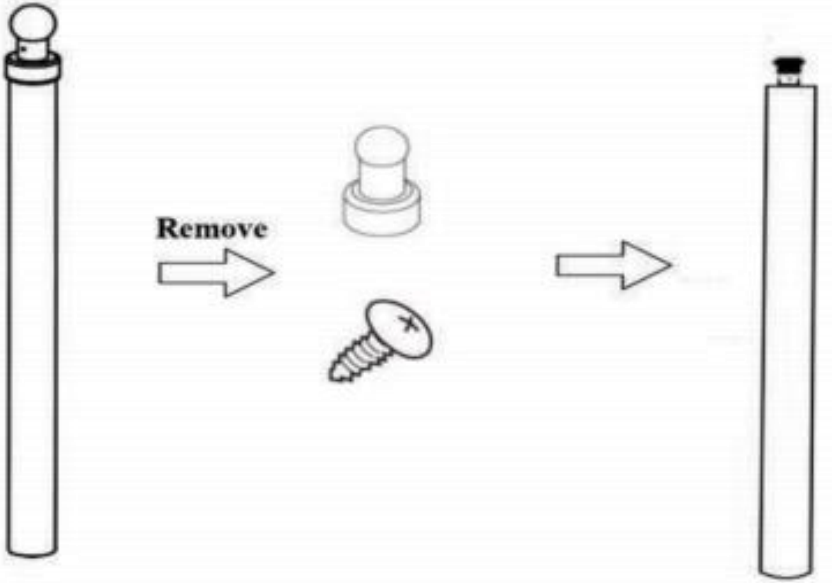

Step 3: Connect D and upper pole tube of trampoline with F.

