

SEVEN DRAWERS CABINET

-Instruction Manual-

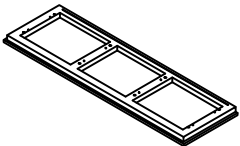

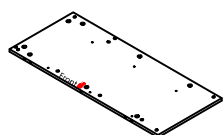

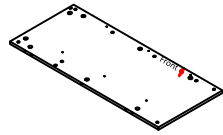
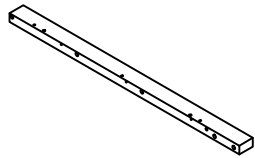
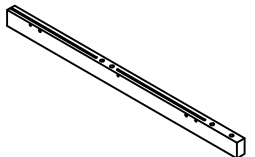
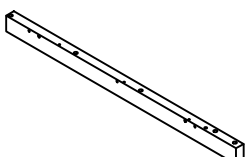
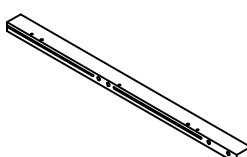
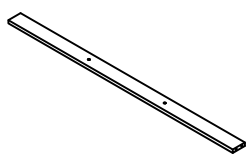
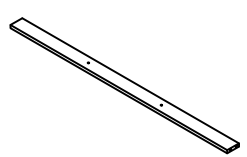
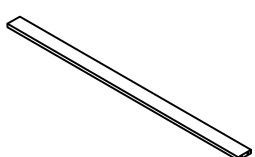
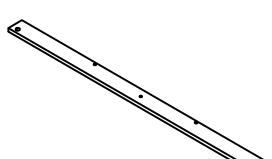
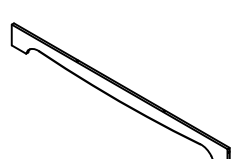
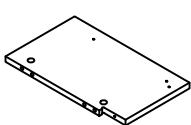
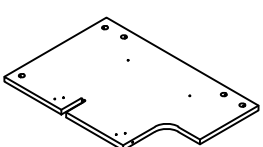
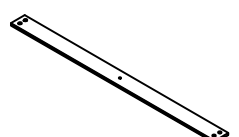
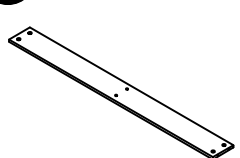
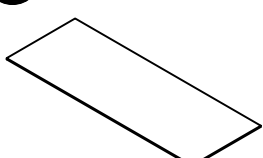
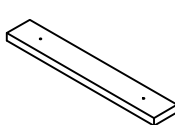
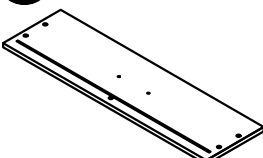
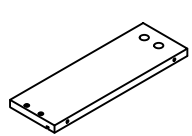
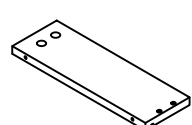
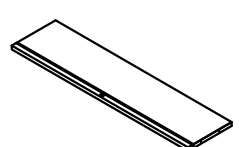
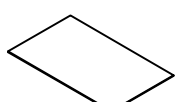
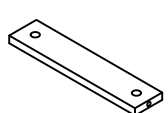
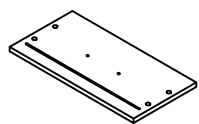
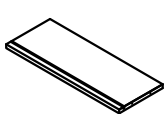
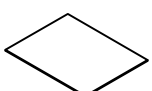

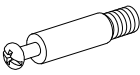

Size: W 51.8xD 15.5xH 31.4 in

HARDWARE LIST

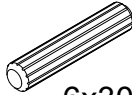
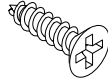
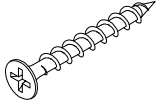
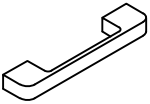
 <p>1 1PC</p>	 <p>2 1PC</p>	 <p>3 1PC</p>	 <p>4 1PC</p>	 <p>5 1PC</p>
 <p>6 1PC</p>	 <p>7 1PC</p>	 <p>8 1PC</p>	 <p>9 2PCS</p>	 <p>10 1PC</p>
 <p>11 1PC</p>	 <p>12 1PC</p>	 <p>13 2PCS</p>	 <p>14 1PC</p>	 <p>15 1PC</p>
 <p>16 1PC</p>	 <p>17 2PCS</p>	 <p>18 4PCS</p>	 <p>19 4PCS</p>	 <p>20 7PCS</p>
 <p>21 7PCS</p>	 <p>22 4PCS</p>	 <p>23 4PCS</p>	 <p>24 4PCS</p>	 <p>25 3PCS</p>
 <p>26 3PCS</p>	 <p>27 3PCS</p>			

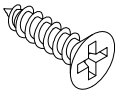
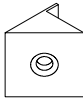
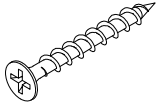
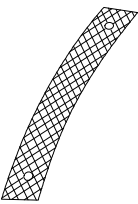
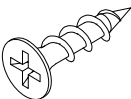
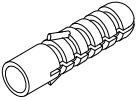
HARDWARE LIST

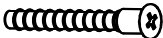
<p>A</p>  <p>6x35mm 93(+2)PCS</p>	<p>B</p>  <p>93(+2)PCS</p>	<p>C</p>  <p>6x30mm 18(+1)PCS</p>	<p>D</p>  <p>M3.5x12mm 70(+2)PCS</p>	<p>E</p>  <p>M3.5x35mm 30(+2)PCS</p>
<p>F</p>  <p>7PCS</p>	<p>G</p>  <p>M4x16mm 14PCS</p>	<p>H</p>  <p>M3x14mm 12(+1)PCS</p>	<p>I</p>  <p>12PCS</p>	<p>J</p>  <p>M3.5x25mm 8(+1)PCS</p>
<p>K</p>  <p>2PCS</p>	<p>L</p>  <p>M3.5x16mm 2PCS</p>	<p>M</p>  <p>2PCS</p>	<p>N</p>  <p>6(+2)PCS</p>	<p>O</p>  <p>7PCS</p>

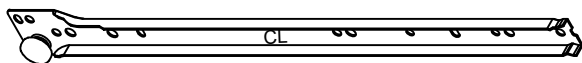

CL
x7
L300mm

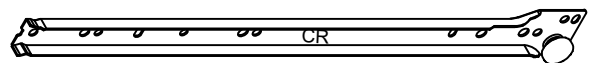

CR
x7
L300mm



DL
x7
L300mm

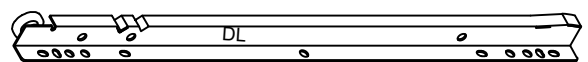

DR
x7
L300mm

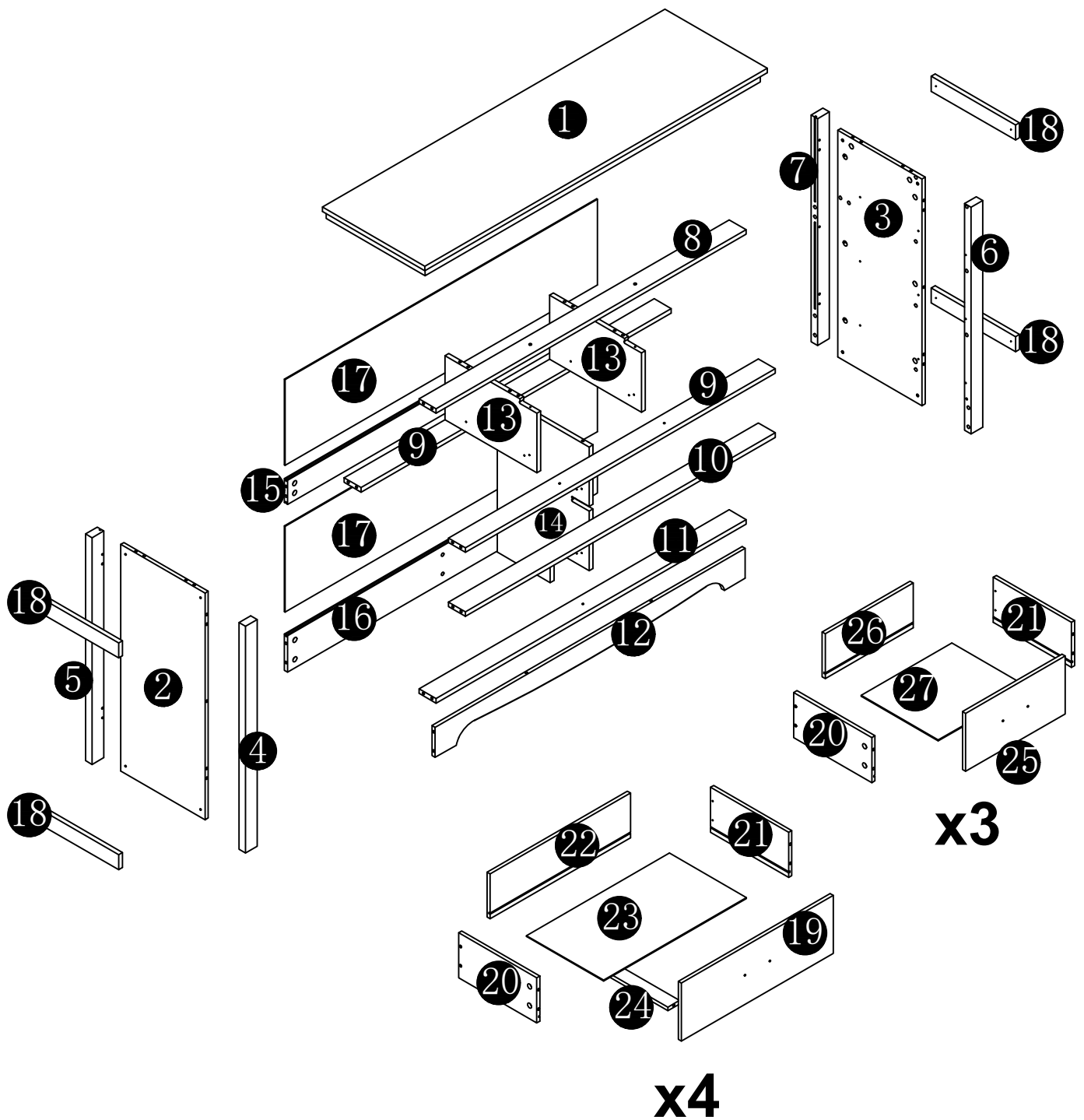

Tips

*This furniture requires 2 people to assemble.
Make sure no parts missing or damaged before assembly.*

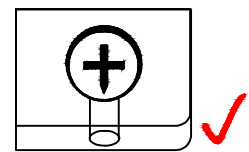
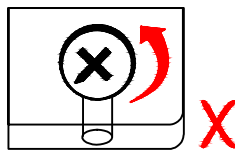
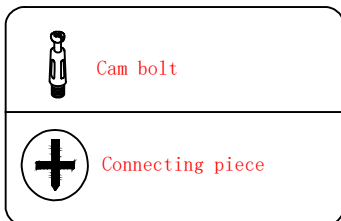
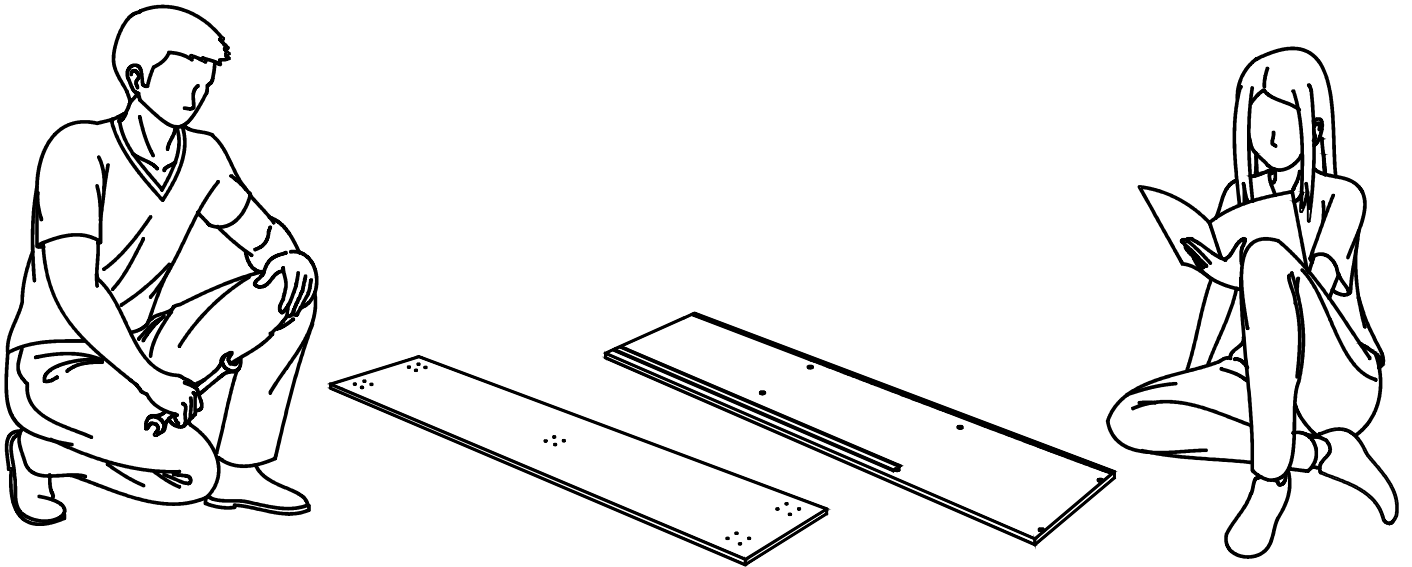

Rotate connecting piece if found in position illustrated above

Correct orientation to receive bolts

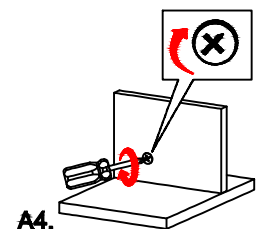
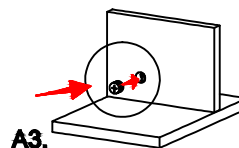
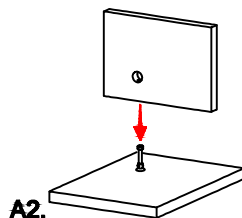
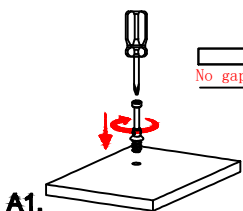
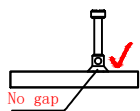
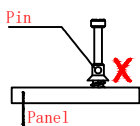

Steps

1

A x15PCS

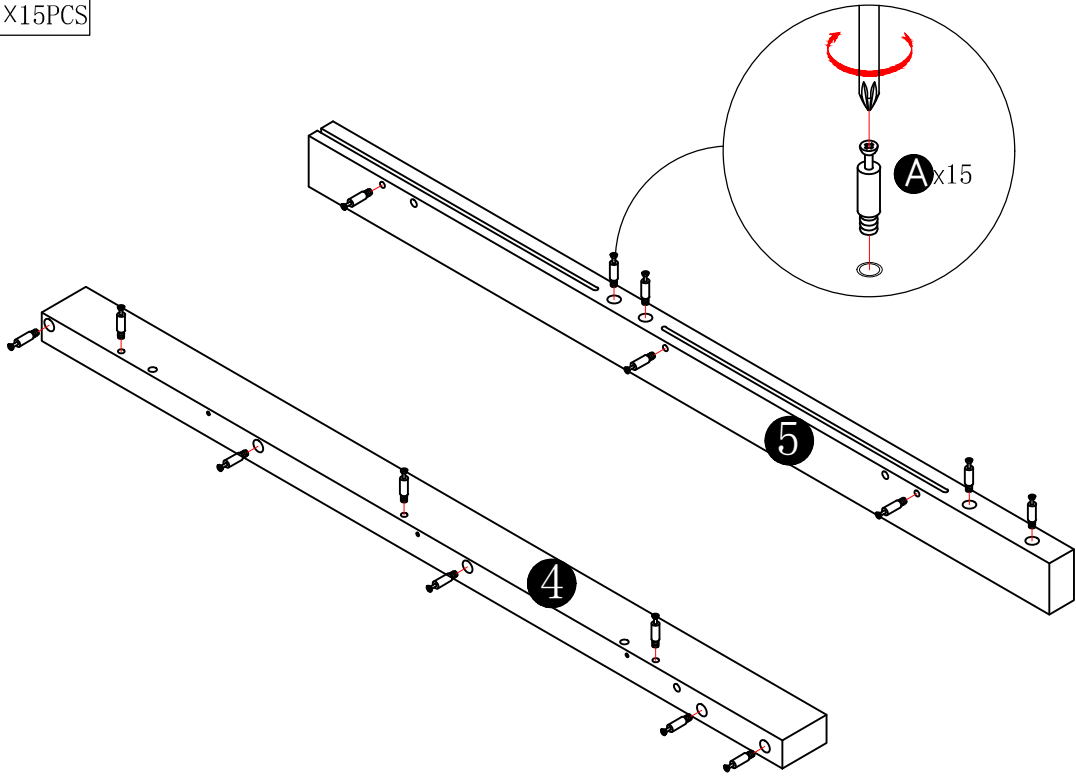

Screw (a) member into hole as shown

2

A x15PCS

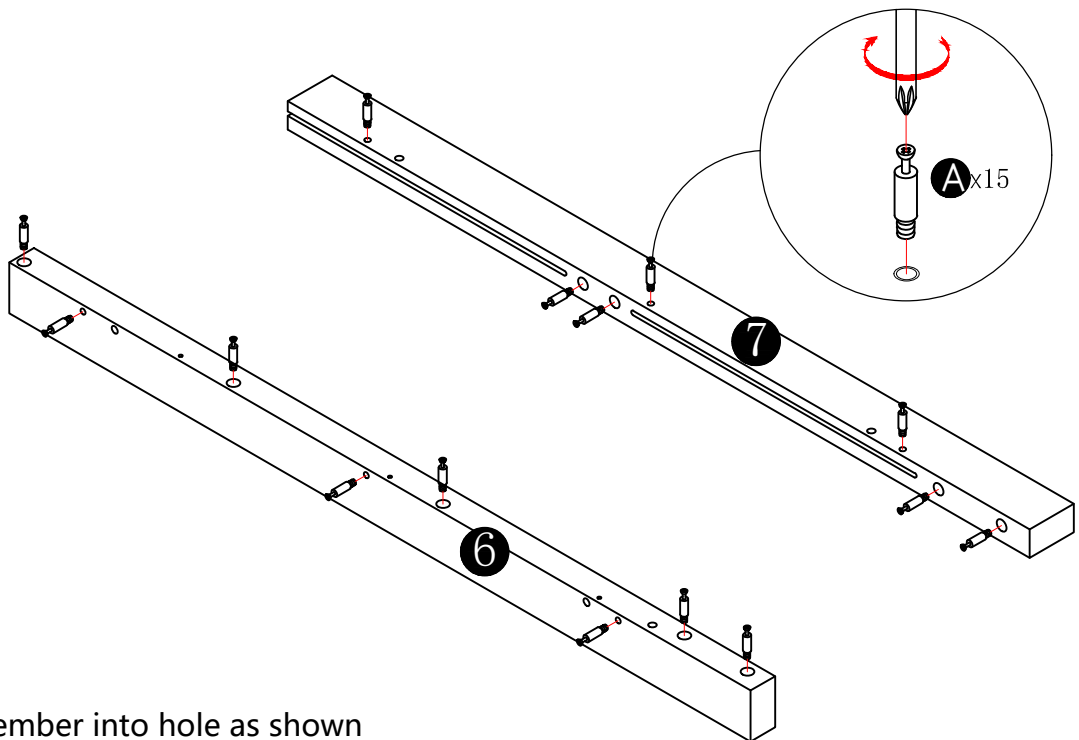

Screw (a) member into hole as shown

Steps

3

A x 6PCS C x 4PCS

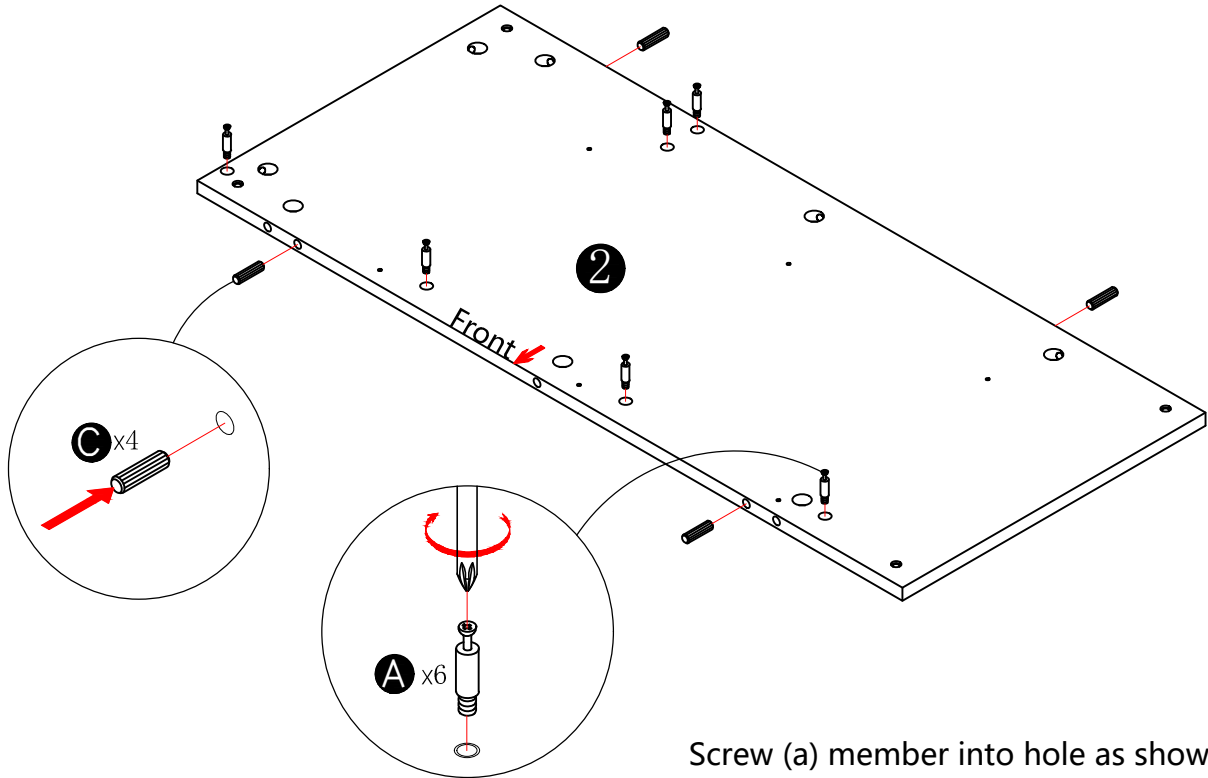

Screw (a) member into hole as shown

4

A x 6PCS C x 4PCS

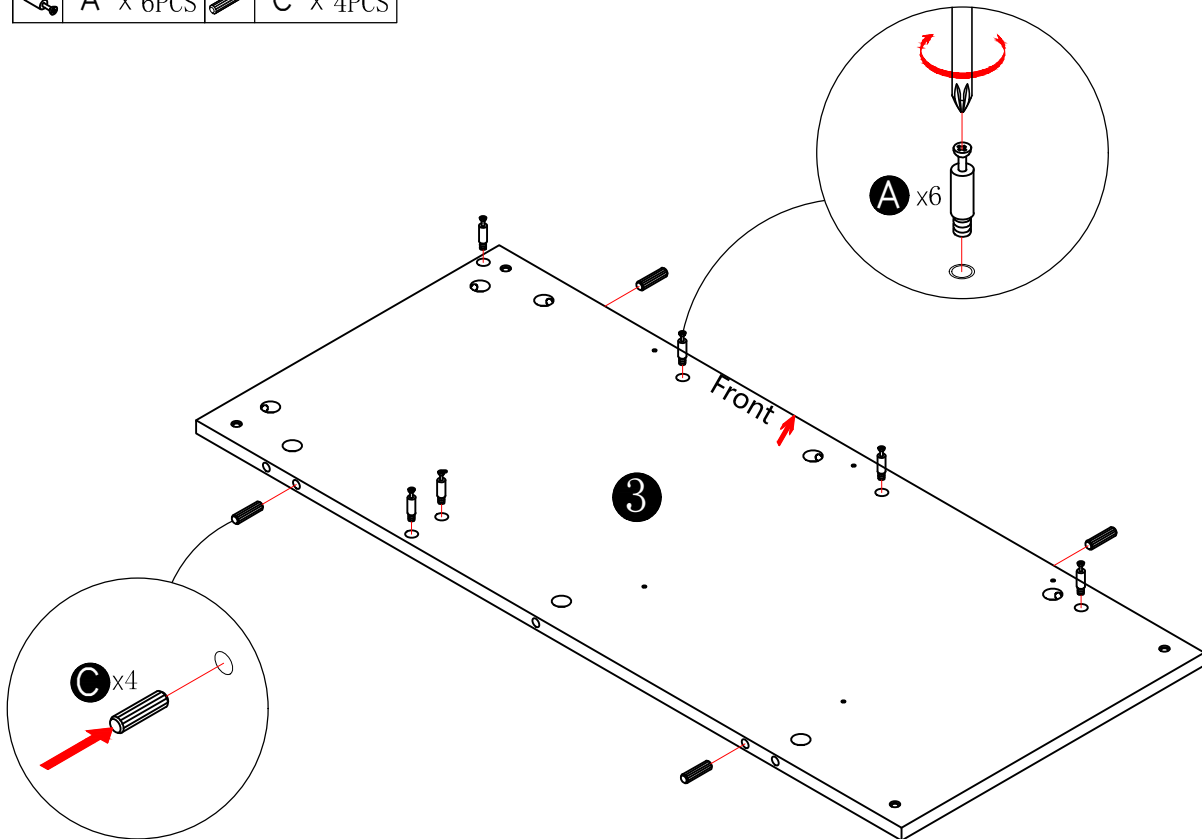

Screw (a) member into hole as shown

Steps

5

 B x 6PCS

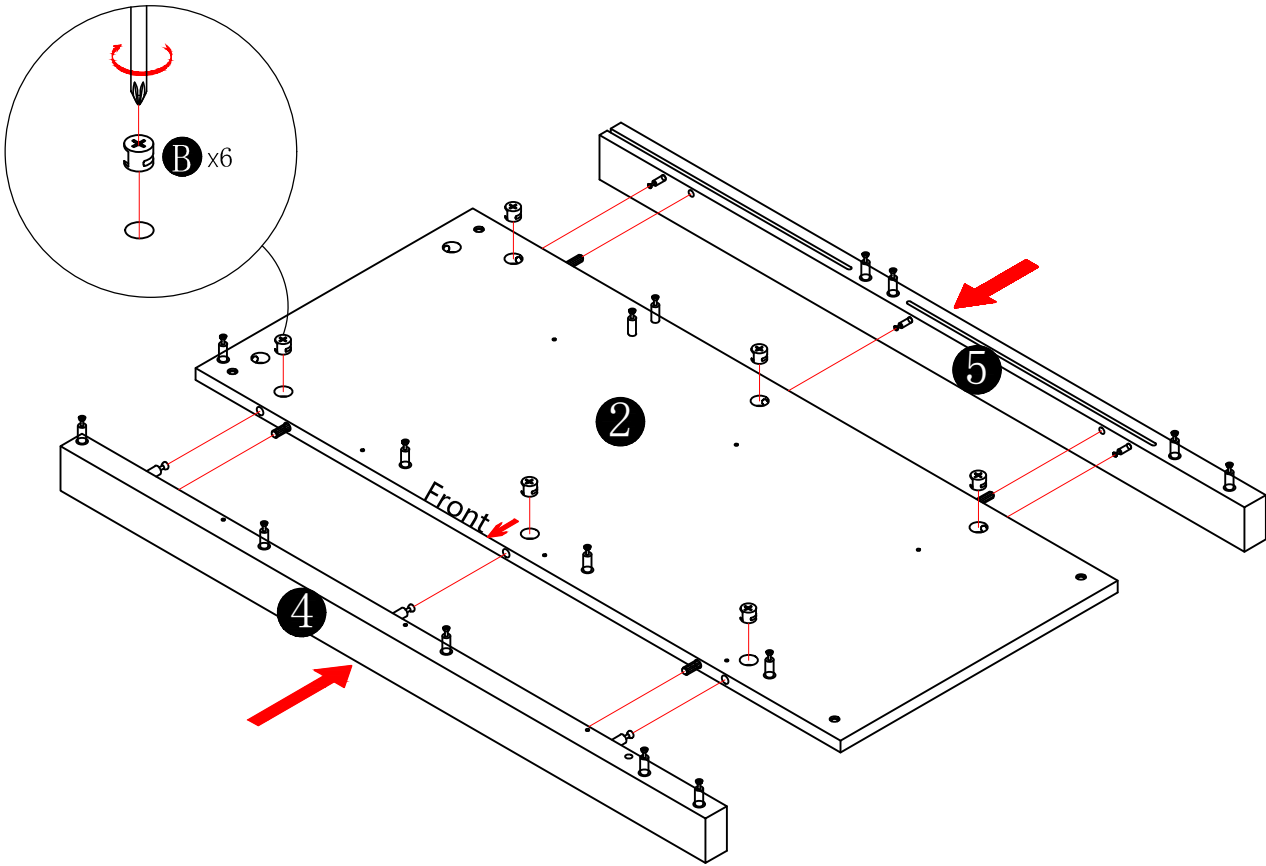

6

 B x 6PCS

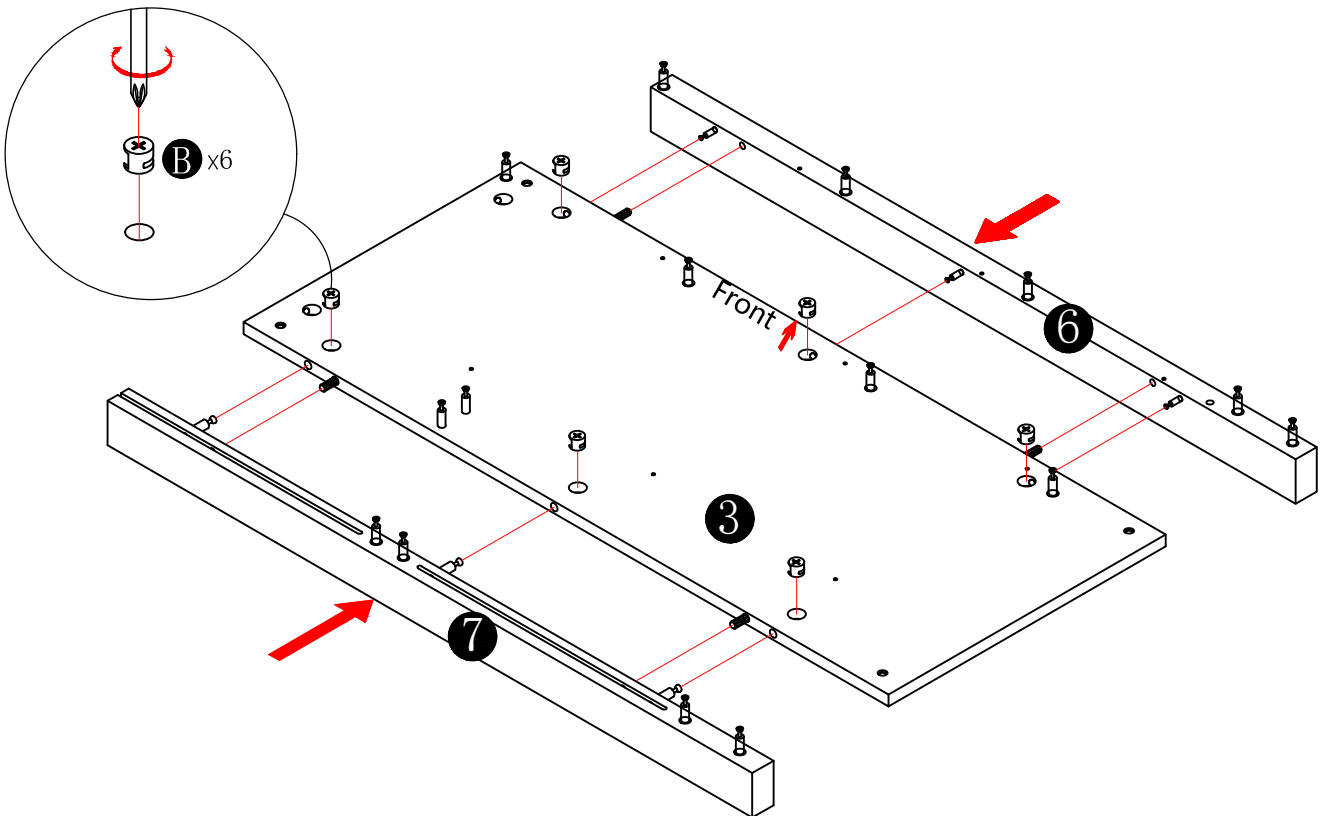

Steps

7  J x 4PCS

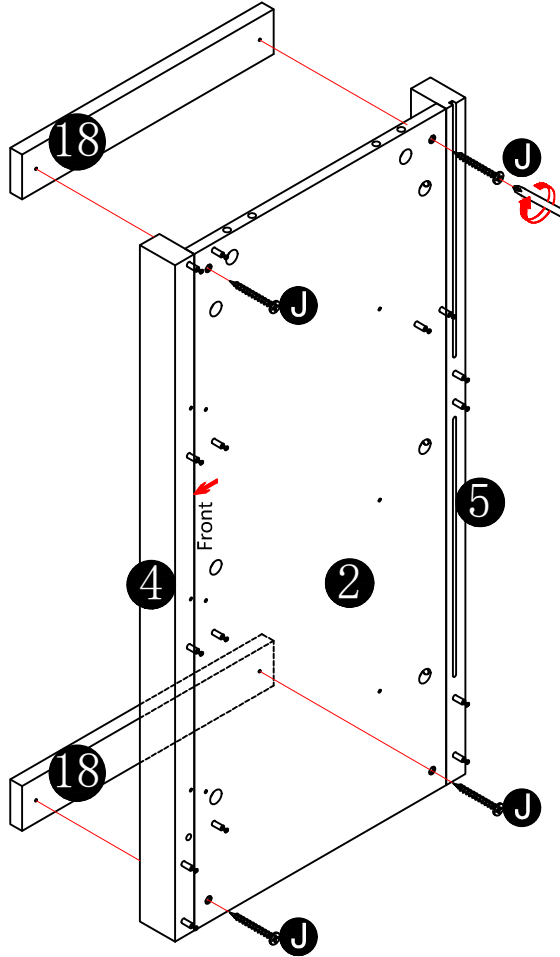

8  J x 4PCS

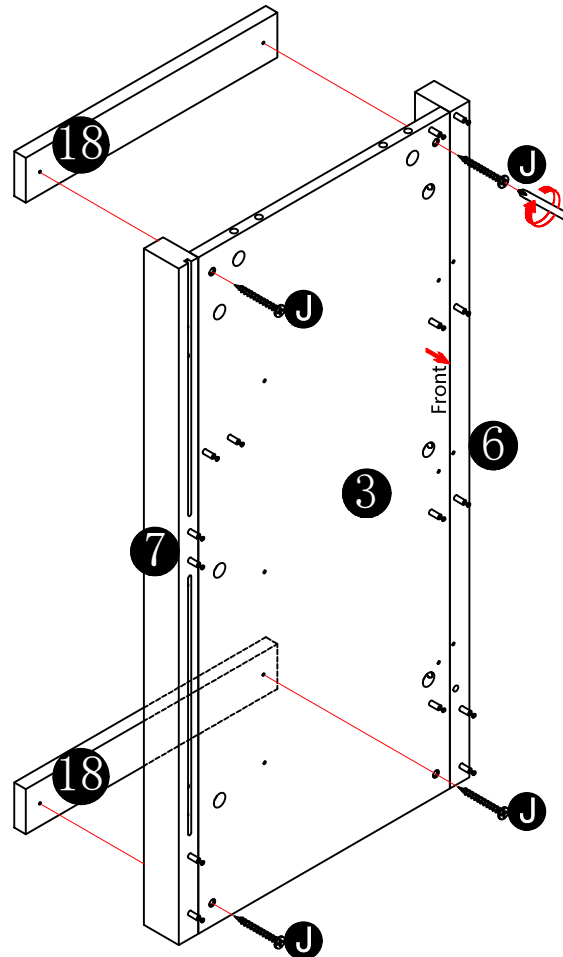

Steps

9

CL x3PCS D x 9PCS N x 2PCS

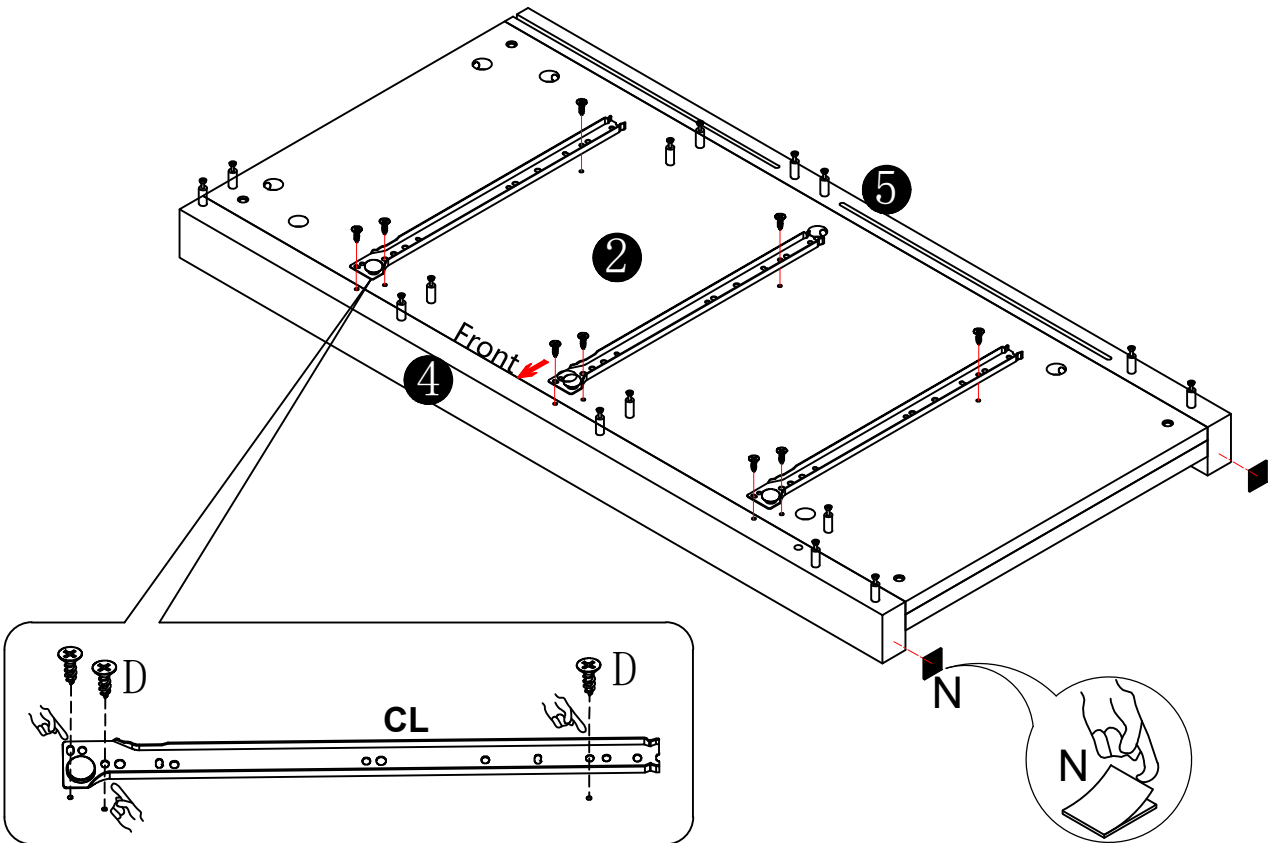



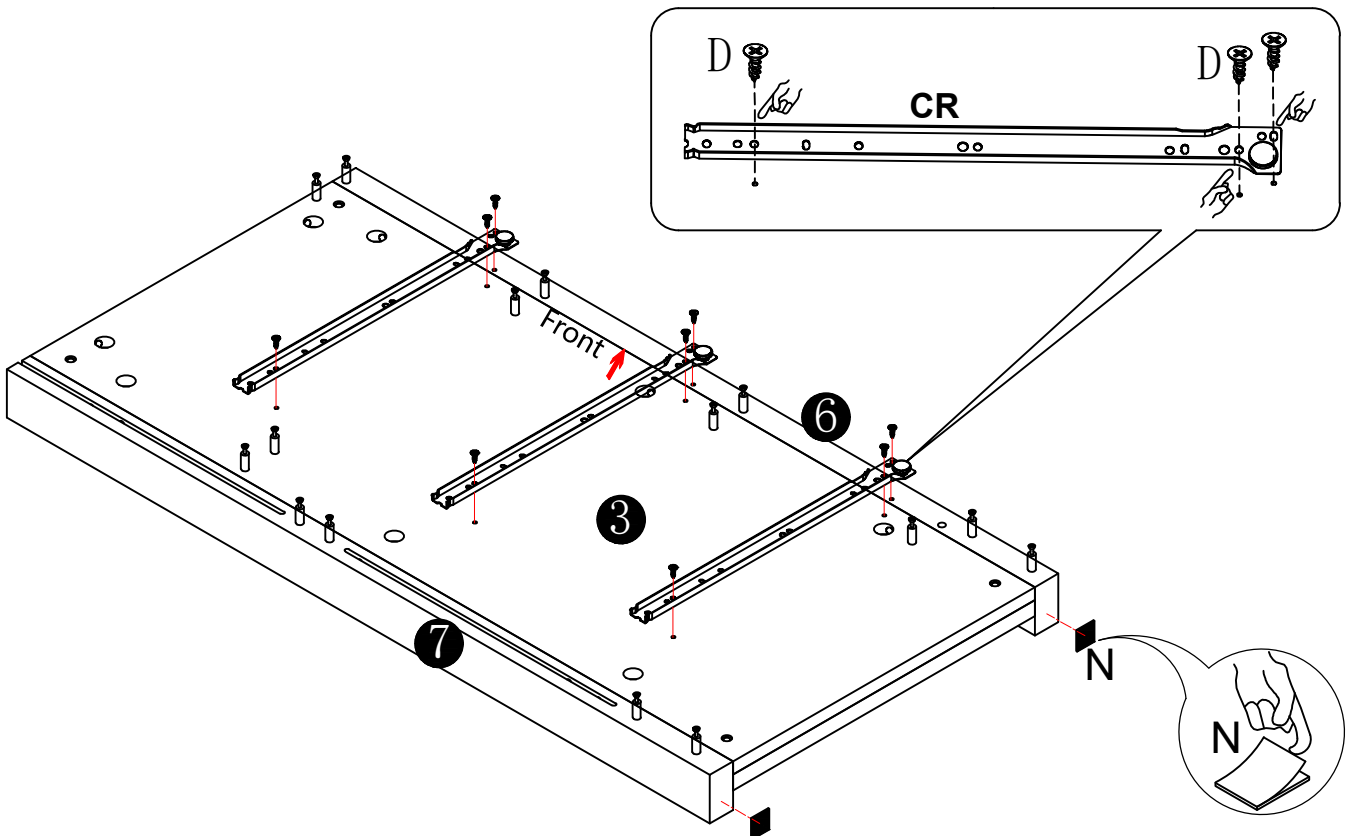

10

CR x3PCS D x 9PCS N x 2PCS





Steps

11

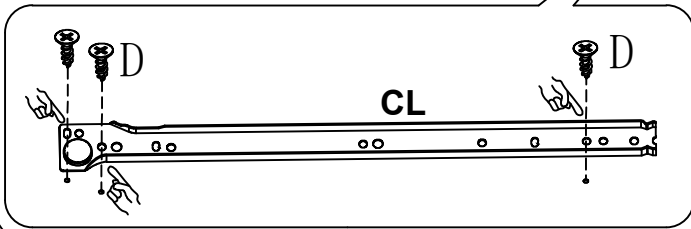
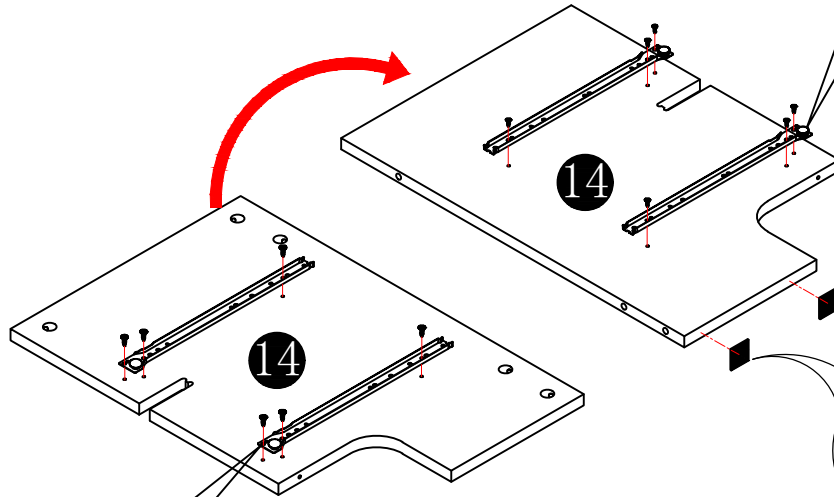
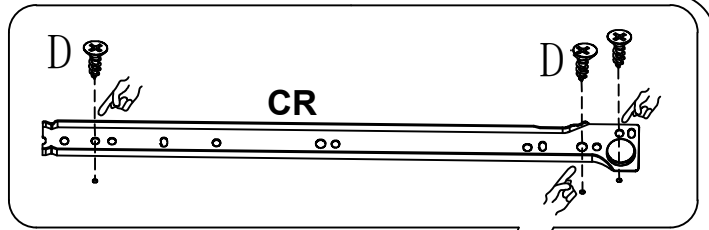
	CL x2PCS
	CR x2PCS
	D x12PCS
	N x 2PCS



12

	CL x2PCS
	CR x2PCS
	D x12PCS

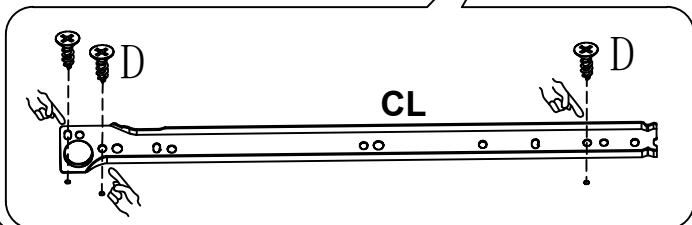
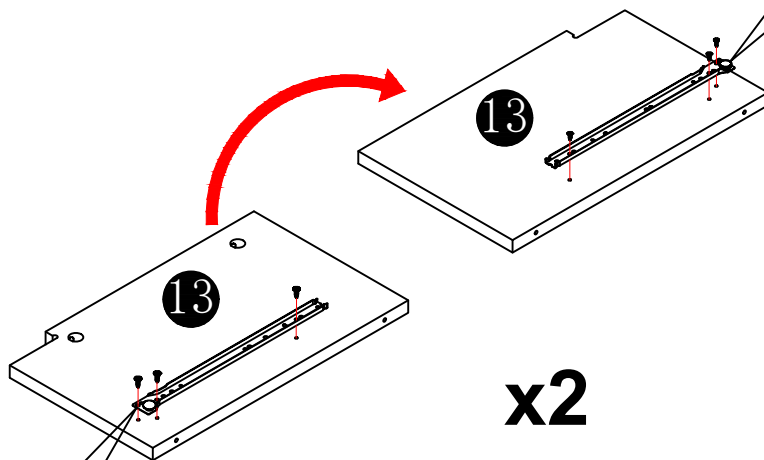
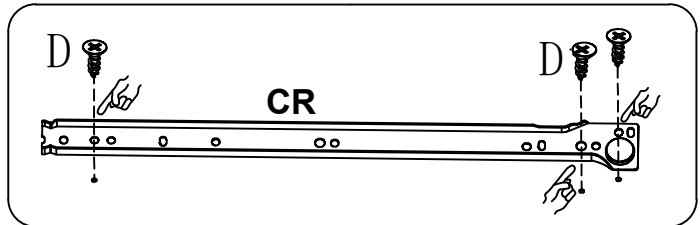

Steps

13

A x 7PCS C x 2PCS

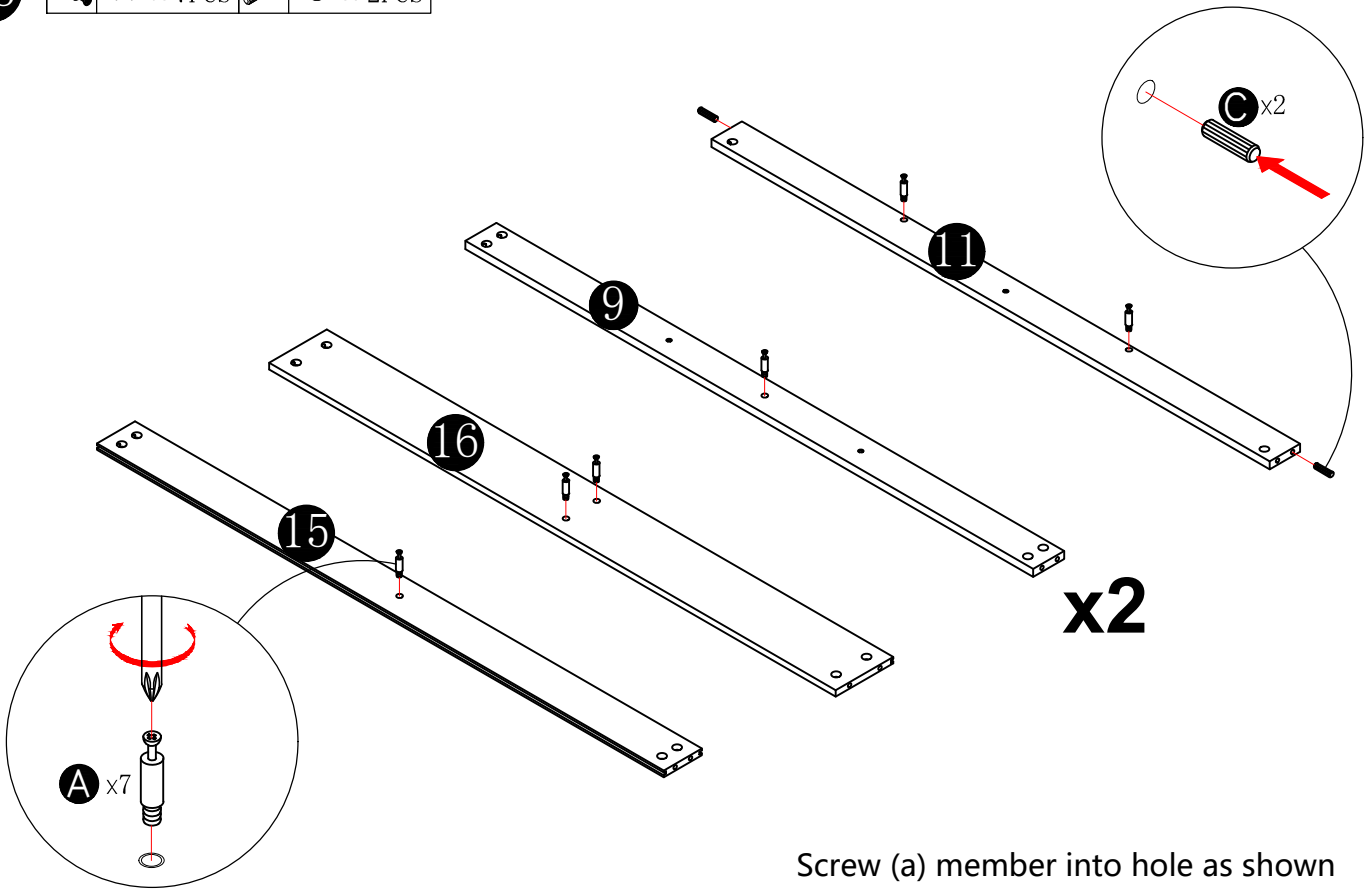

Screw (a) member into hole as shown

14

B x 3PCS

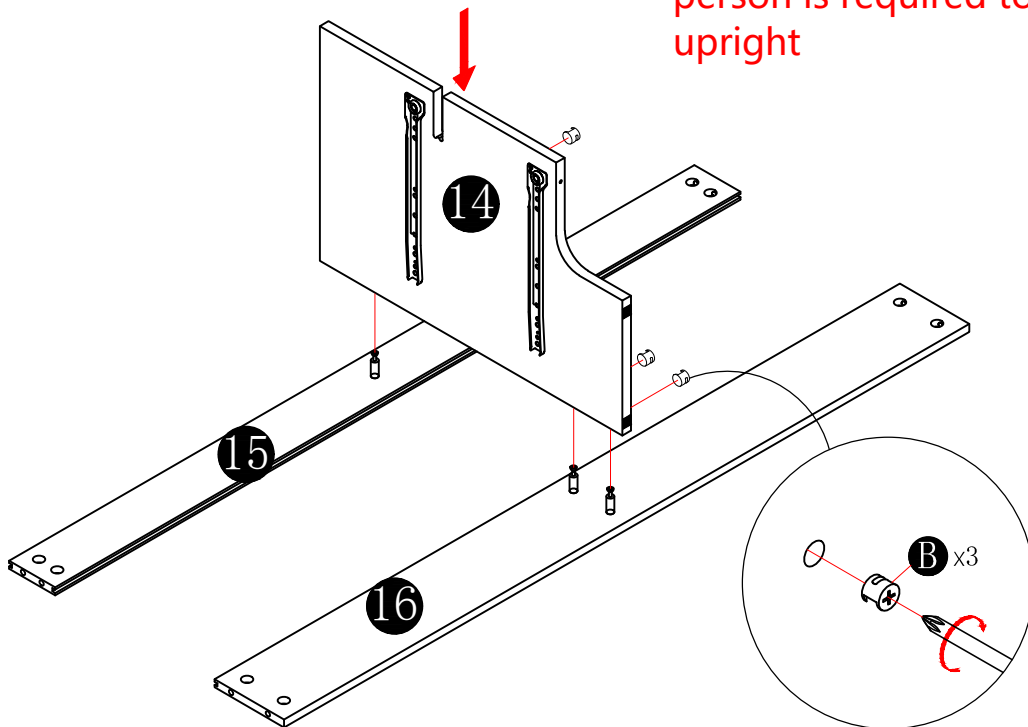

Two people are required to assemble this step, and one person is required to hold it upright

Steps

15

 B x 4PCS

Two people are required to assemble this step, and one person is required to hold it upright

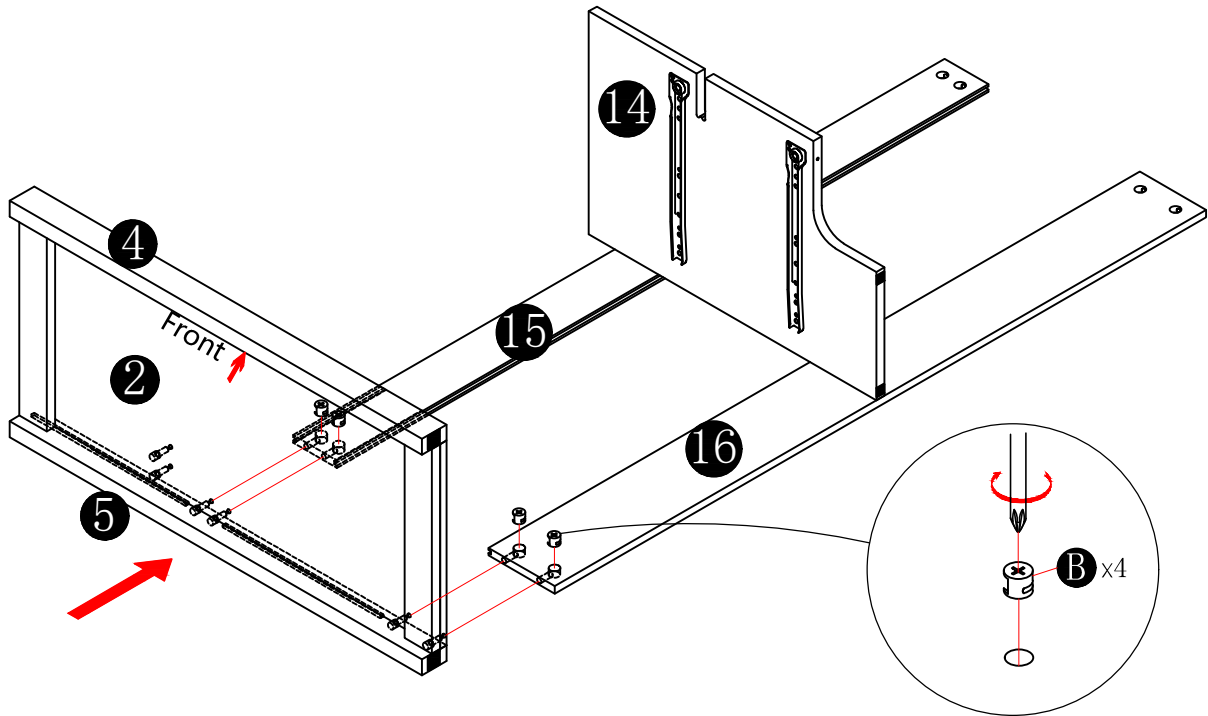

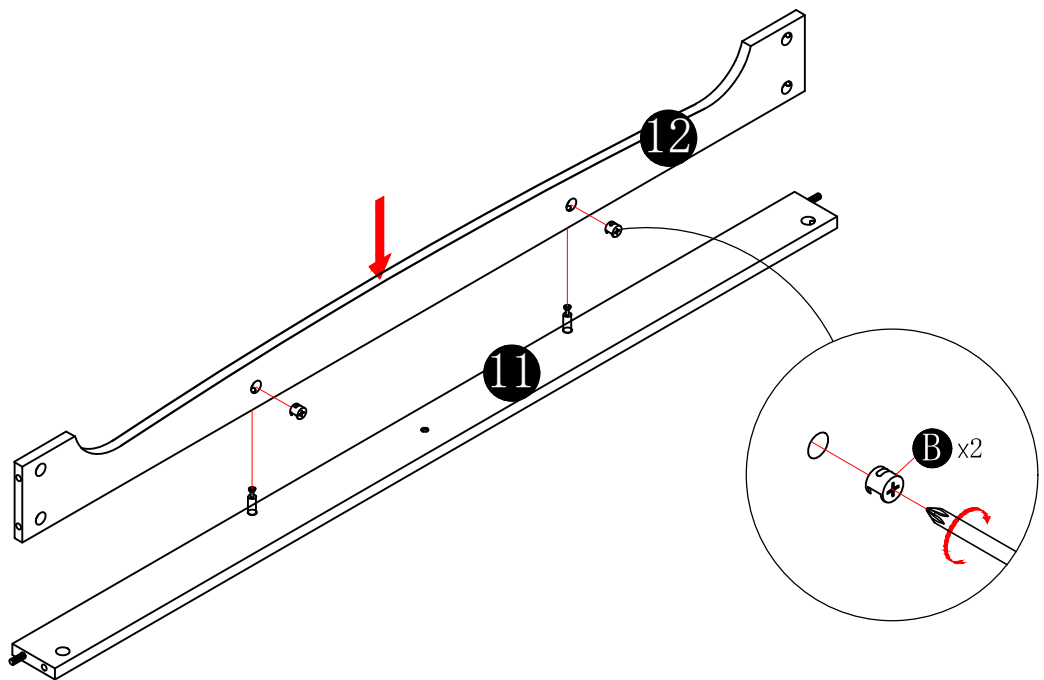

16

 B x 2PCS



Steps

17

 B x 5PCS  O x 1PCS

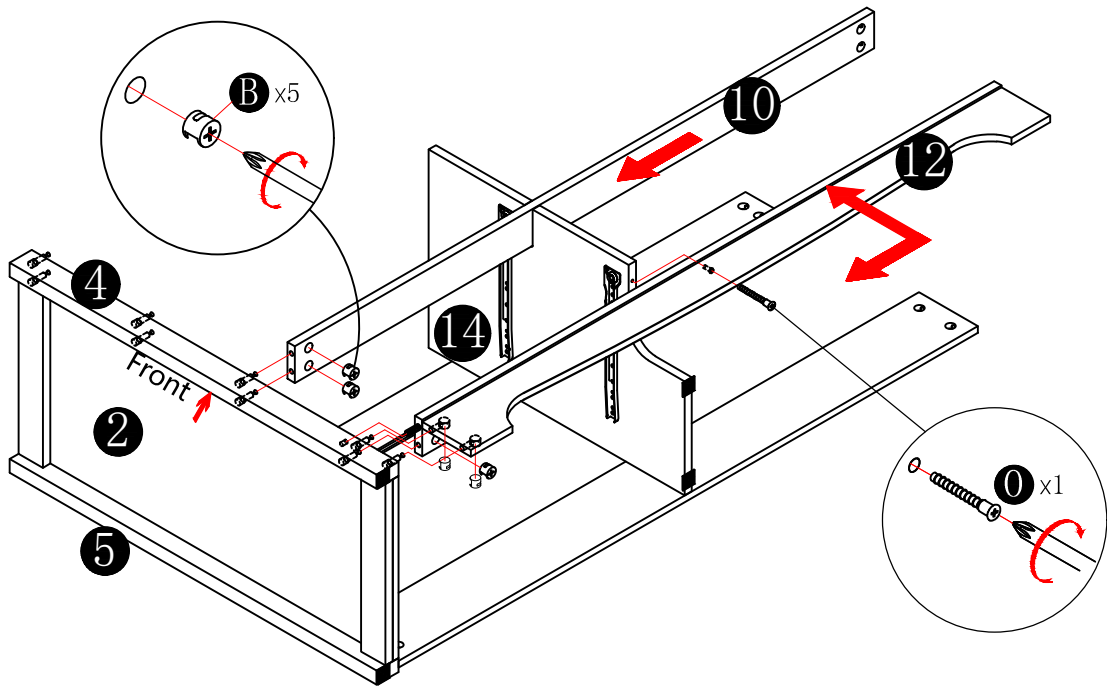

Two people are required to assemble this step

18

 B x 6PCS

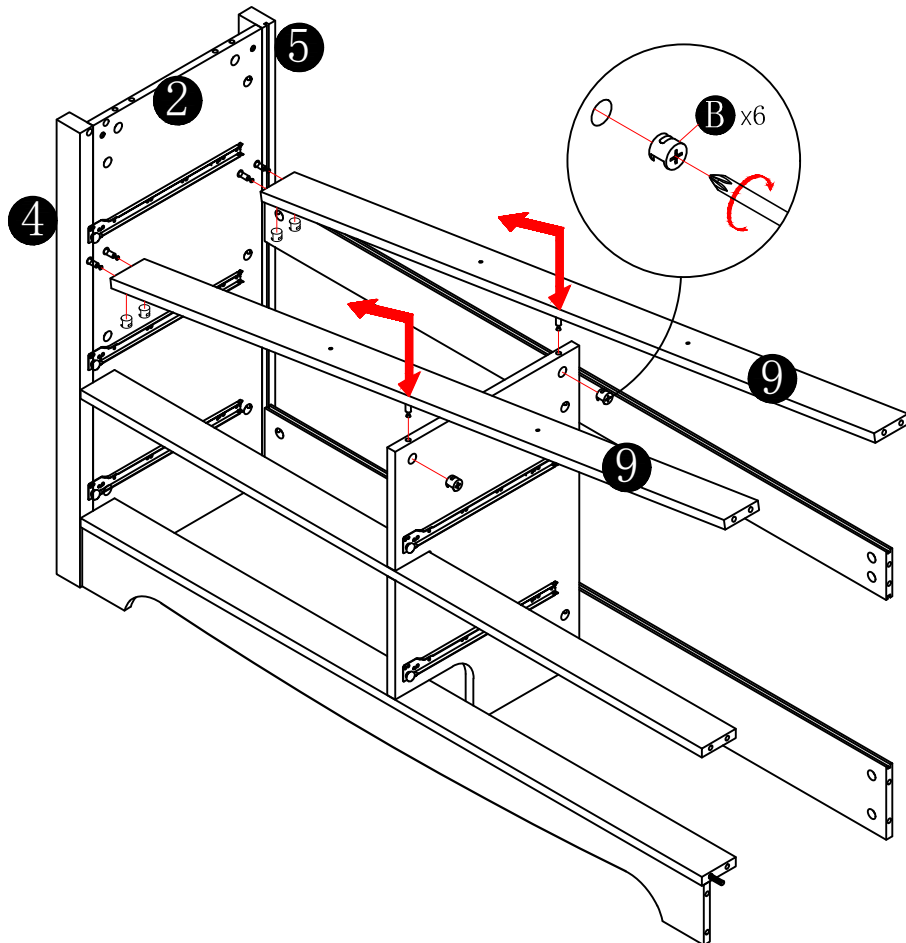

Steps

19

— ○ x 4PCS

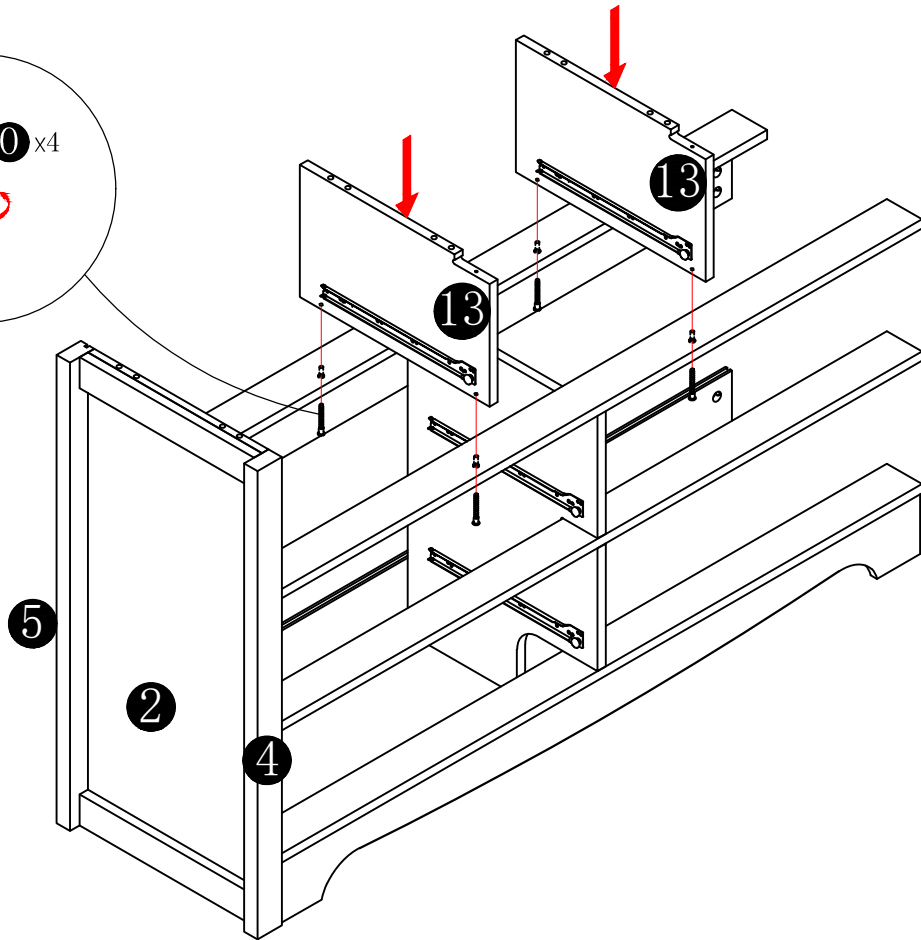
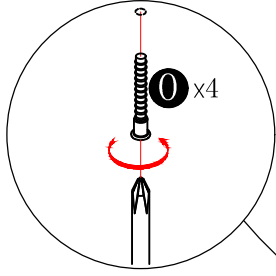

20

— B x 2PCS — ○ x 2PCS

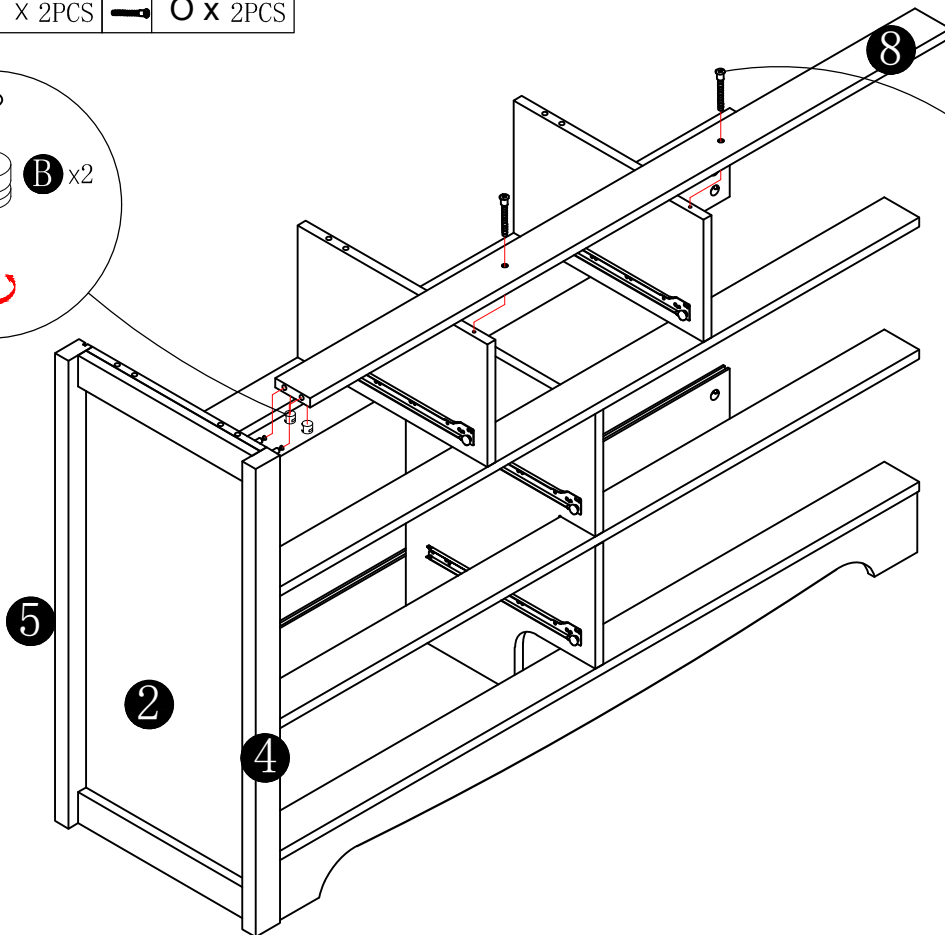
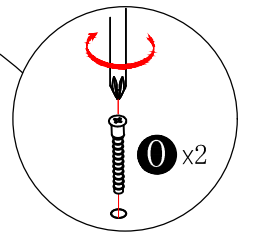
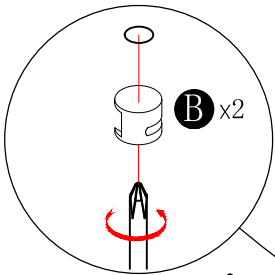

Steps

21

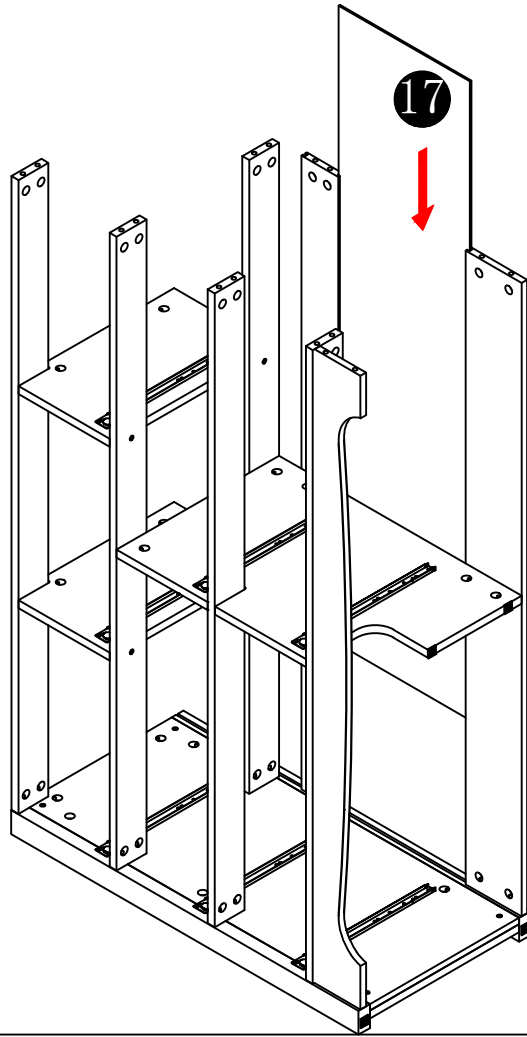

22

 B x15PCS

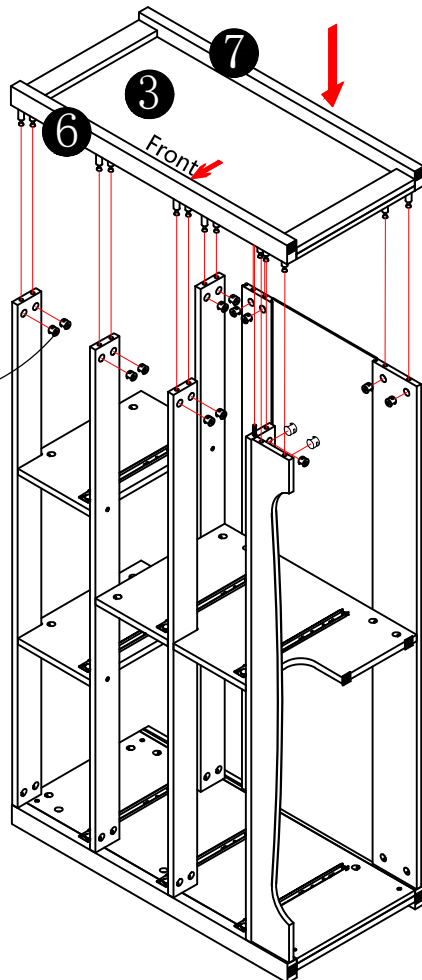
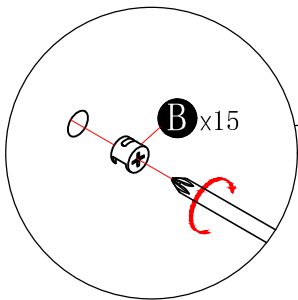

Steps

23

C x 8PCS

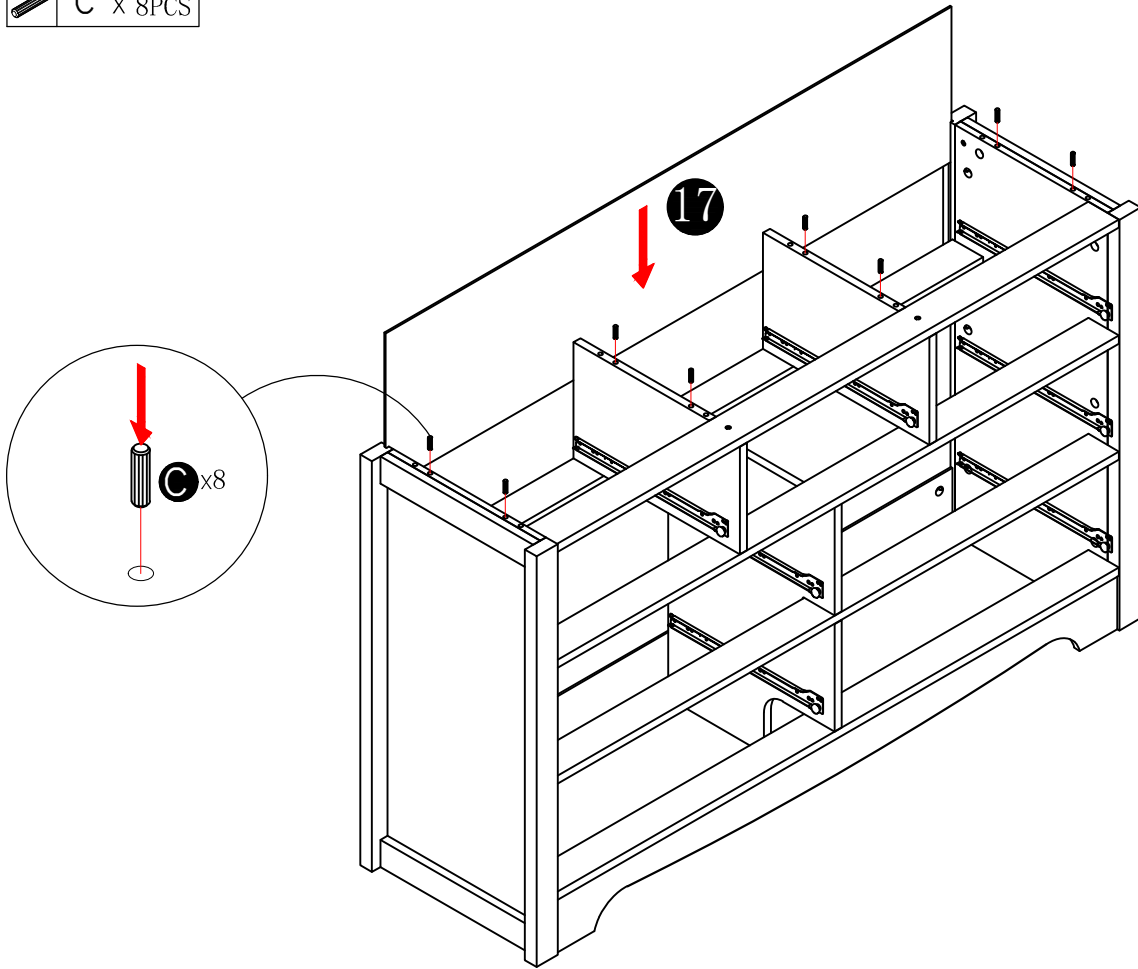

24

A x 8PCS

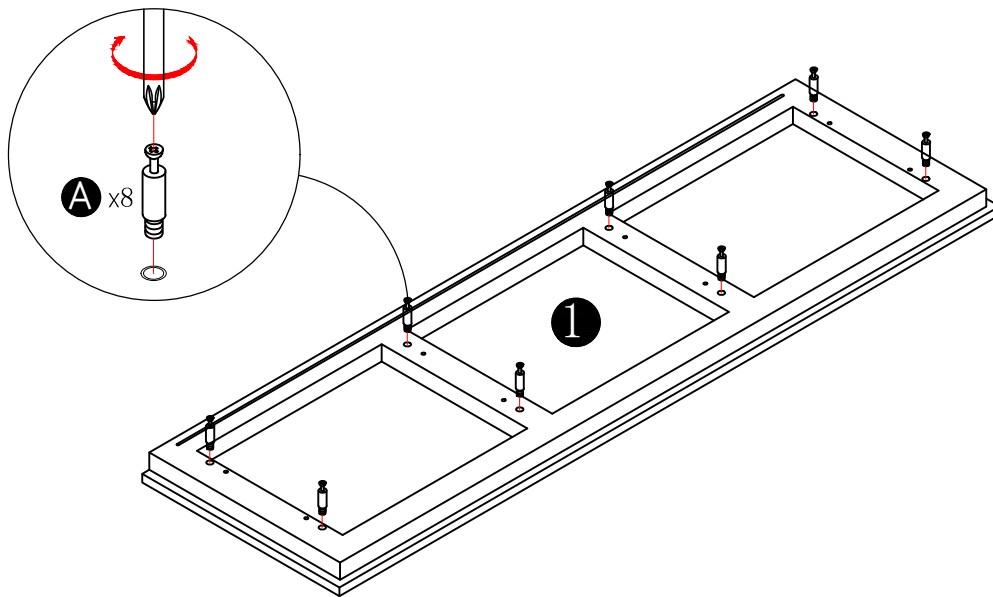

Screw (a) member into hole as shown

Steps

25

 B x 8PCS

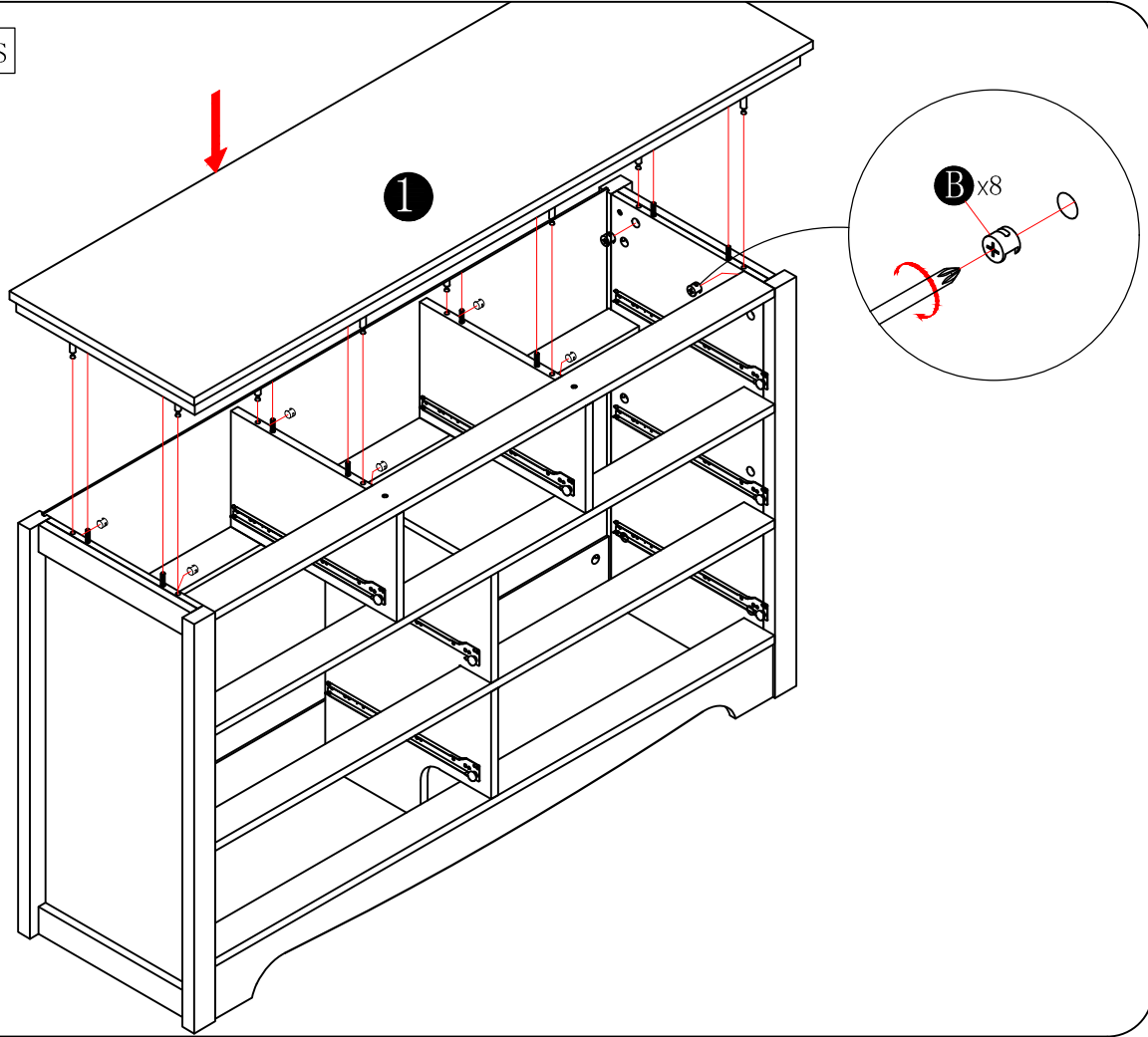

26

 A x 4PCS

Screw (a) member into hole as shown

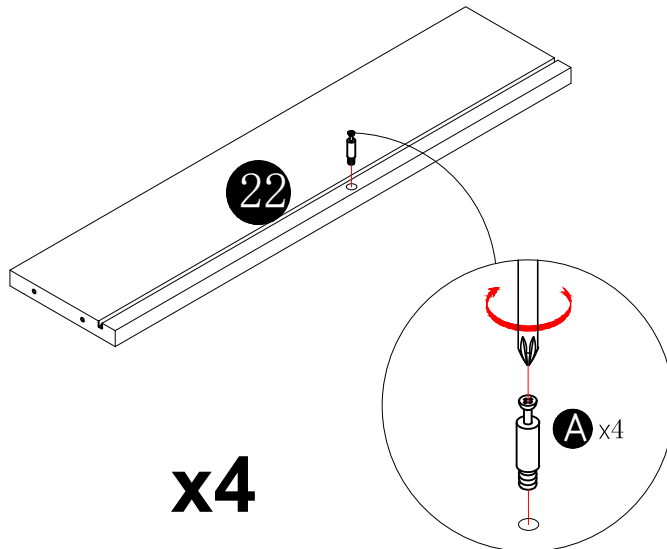

Steps

27

E x16PCS

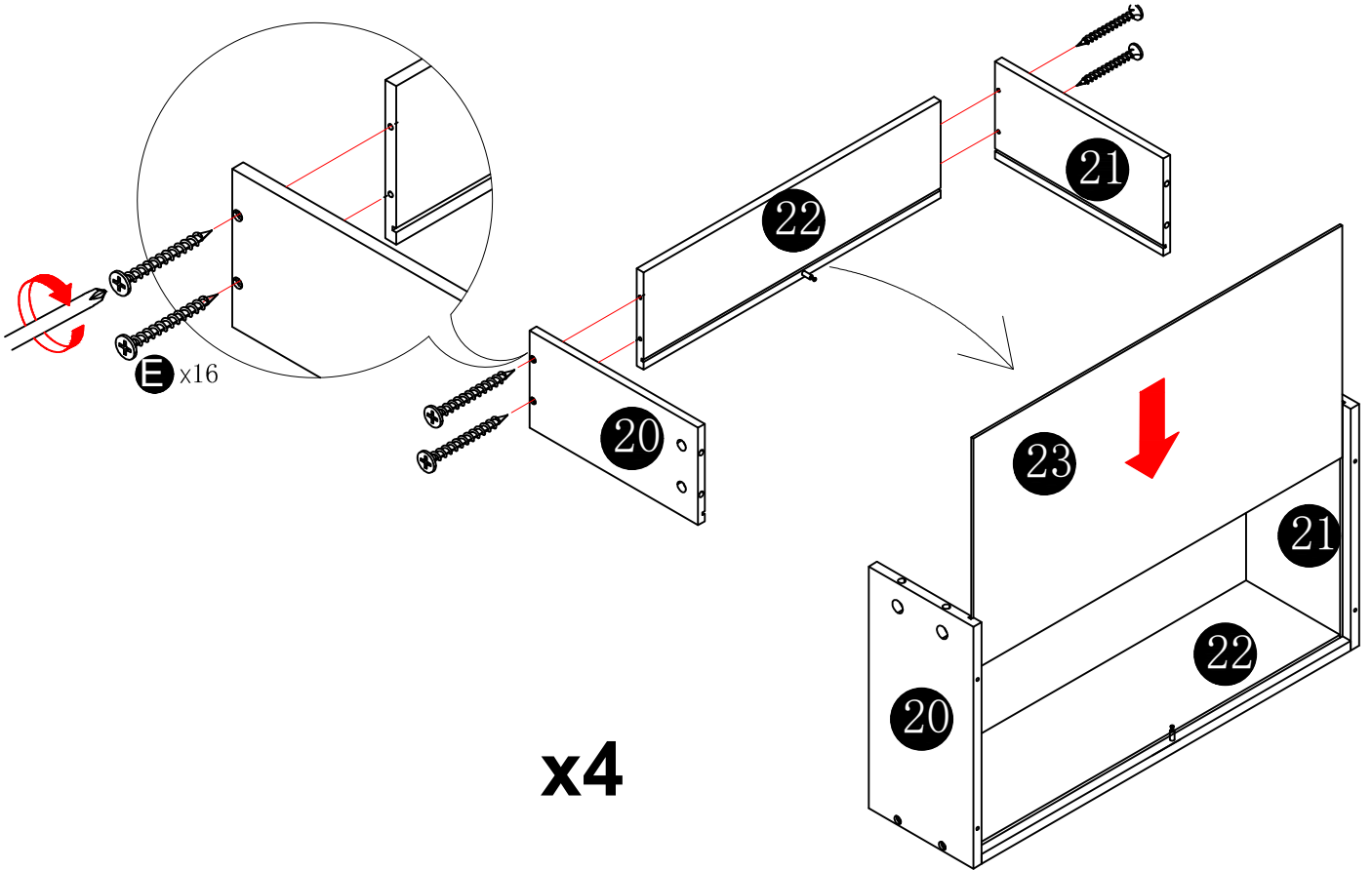

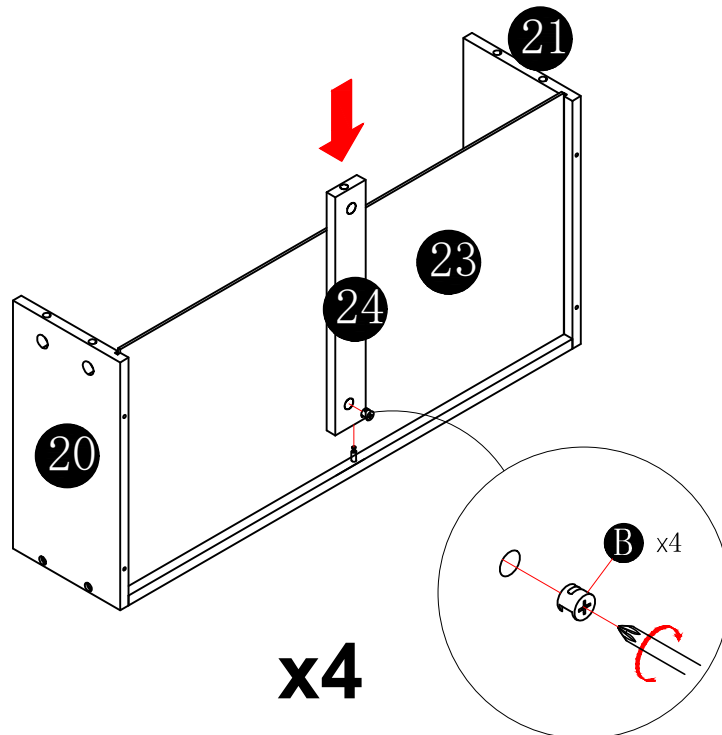

28

B x 4PCS



Steps

29

	A x32PCS
	F x 7PCS
	G x14PCS

Screw (a) member into hole as shown

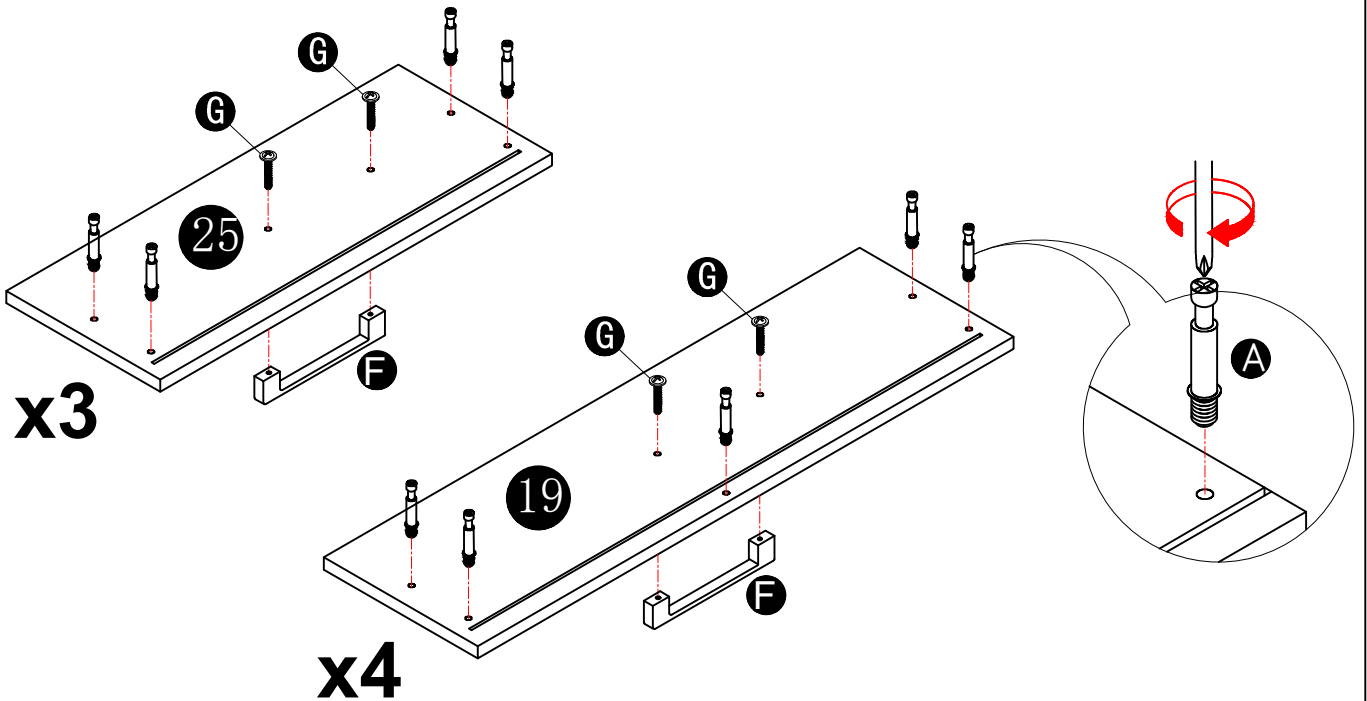

30

	B x20PCS
---	----------

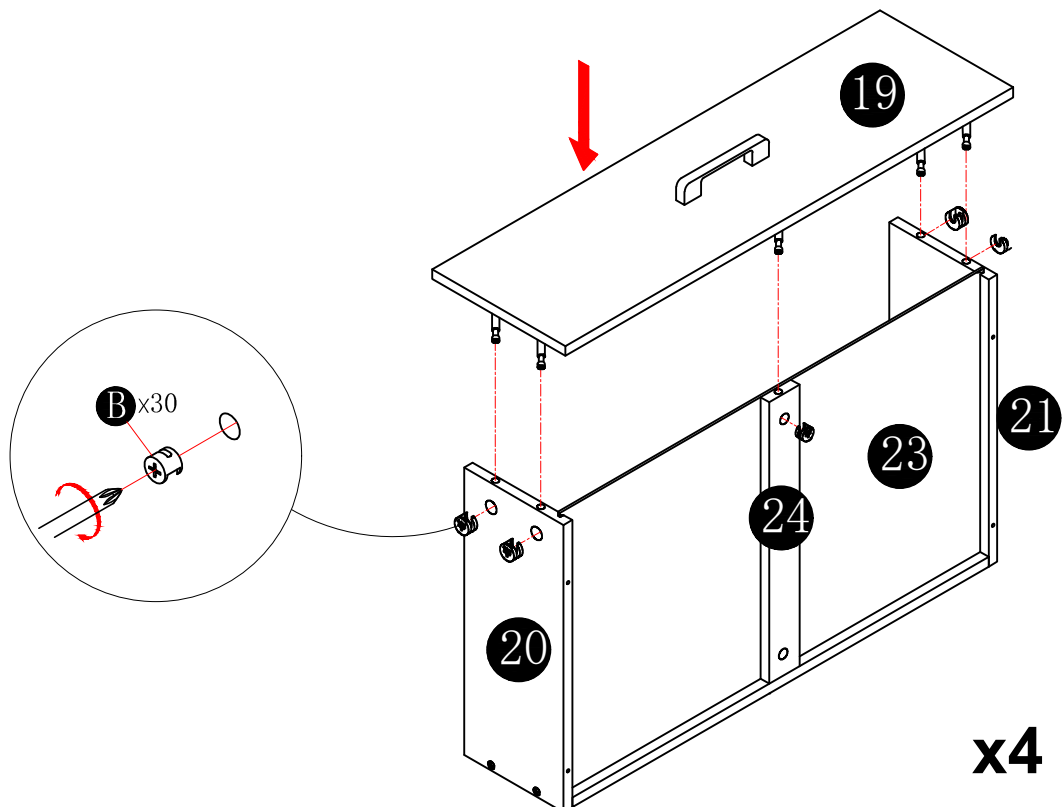

Steps

31

E x12PCS

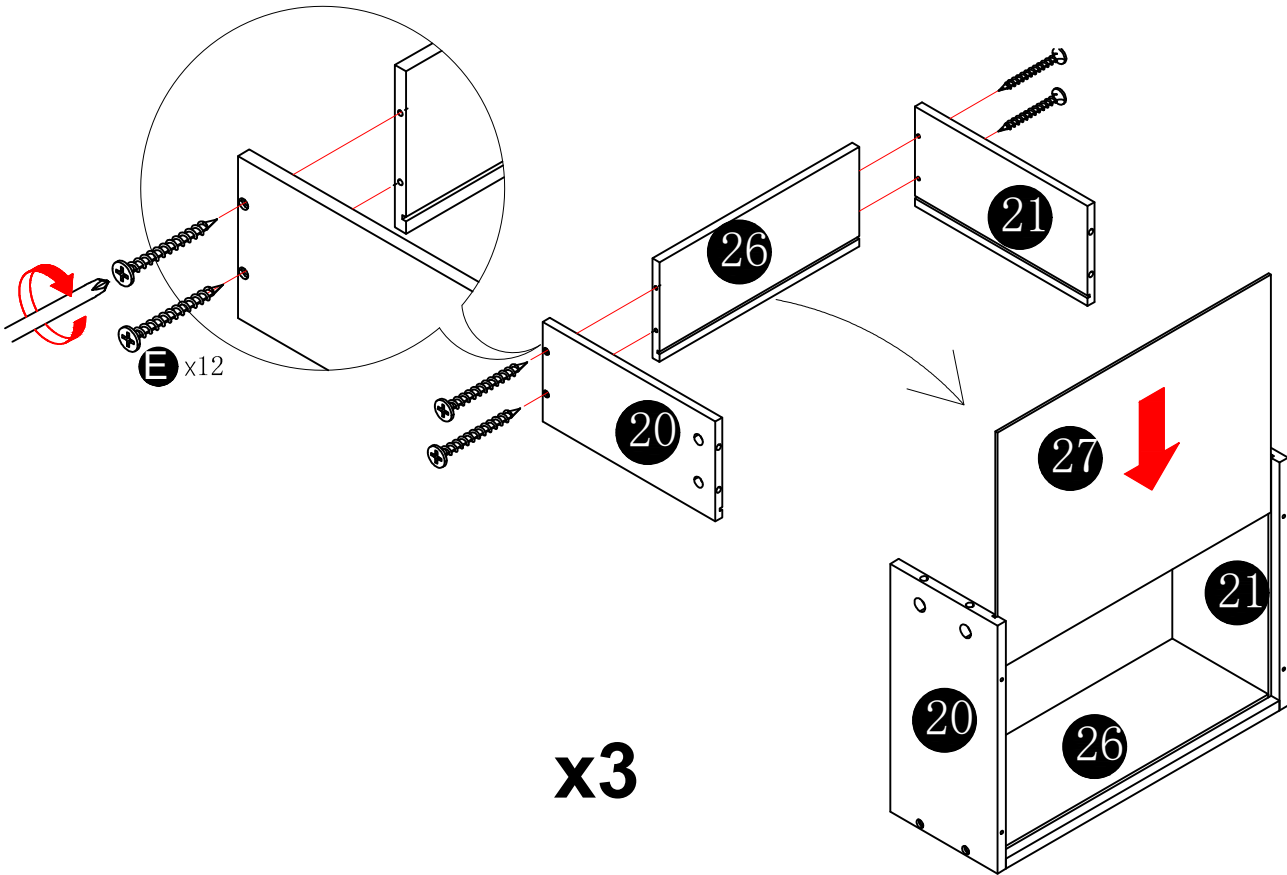

32

B x12PCS

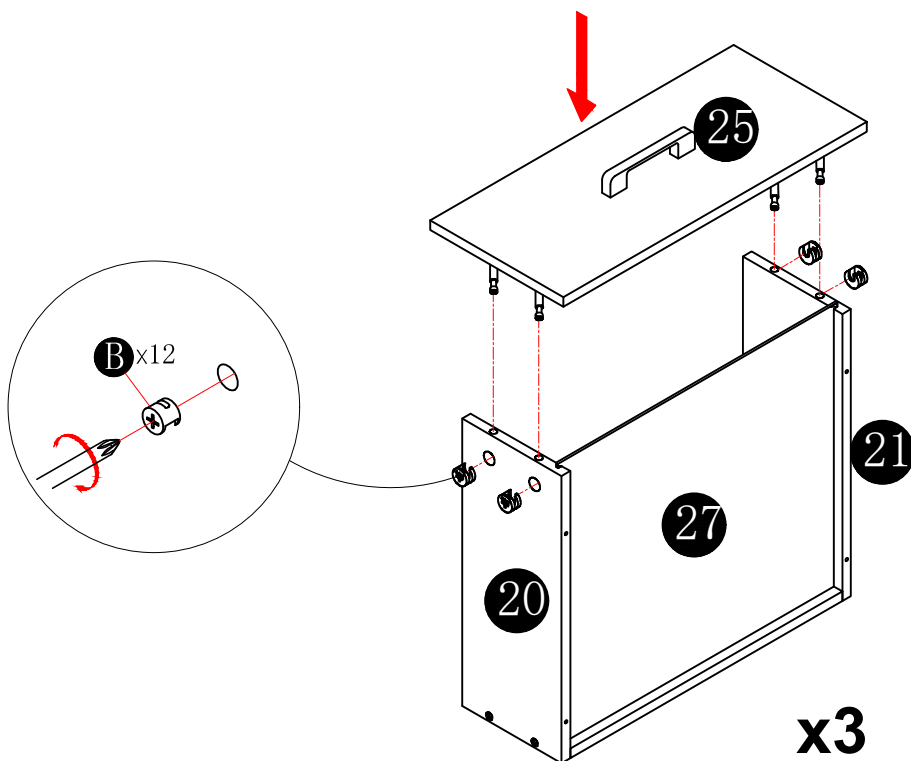

Steps

33

D x16PCS

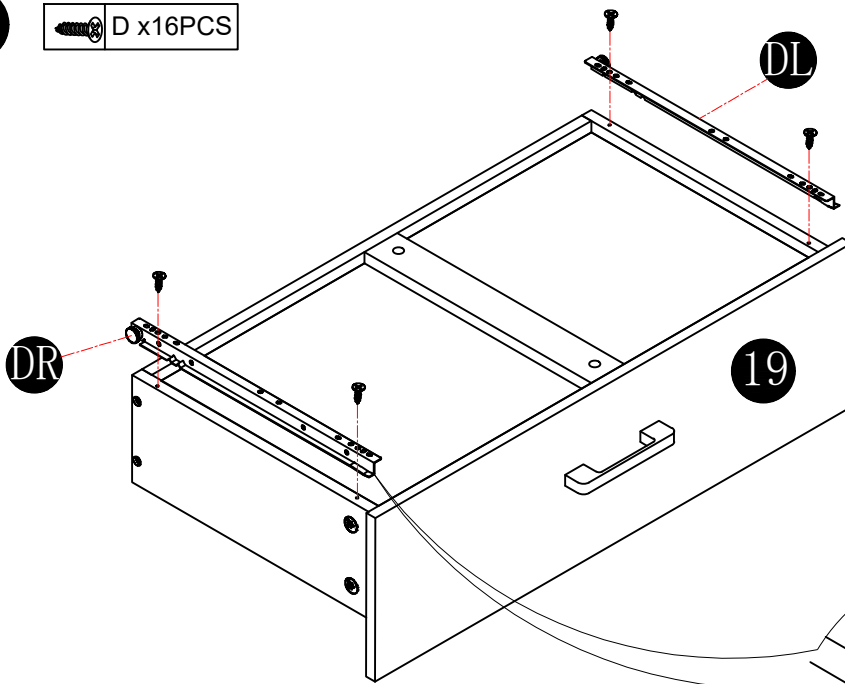

The 4 drawer slides are installed in the same step

x4

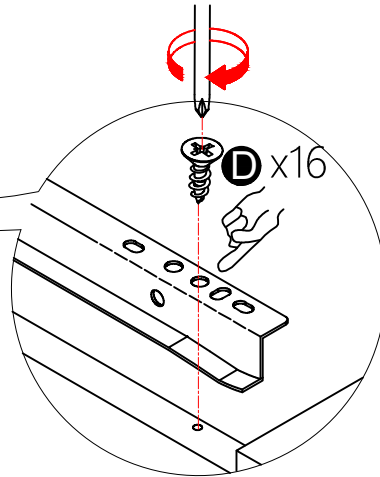

34

D x12PCS

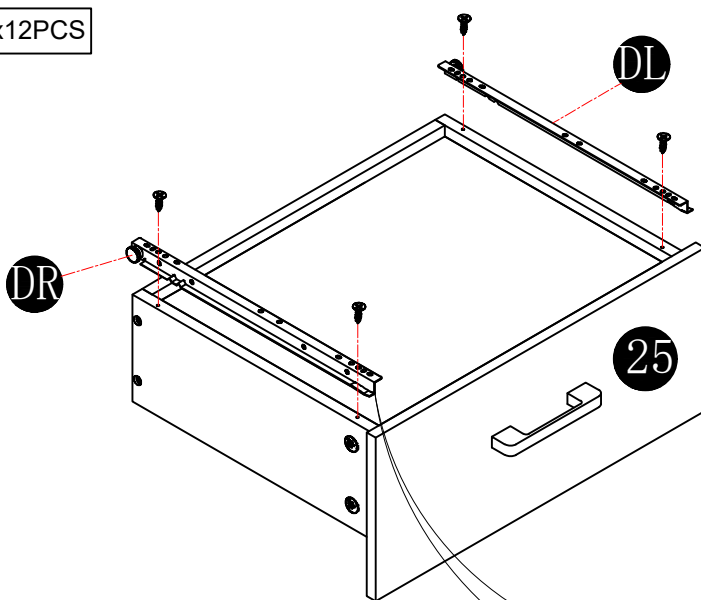

The 3 drawer slides are installed in the same step

x3

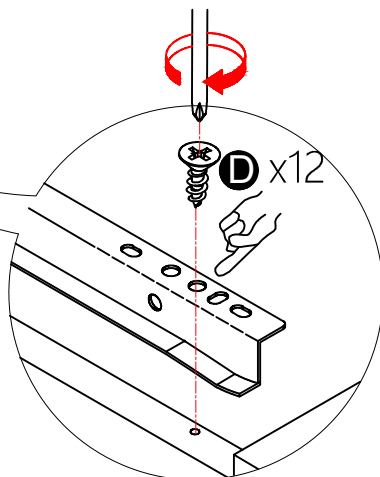

35

(1)

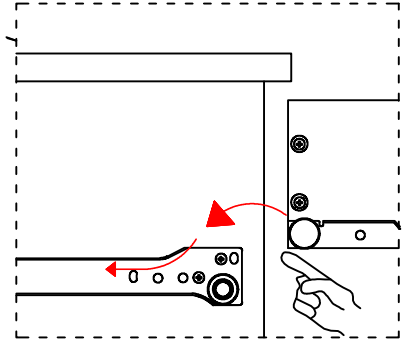
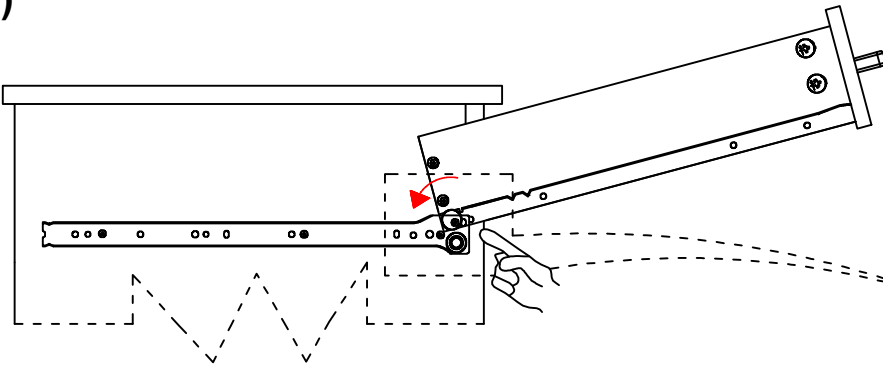

(2)

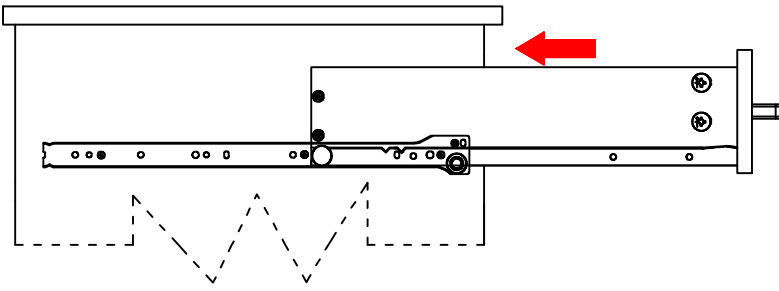



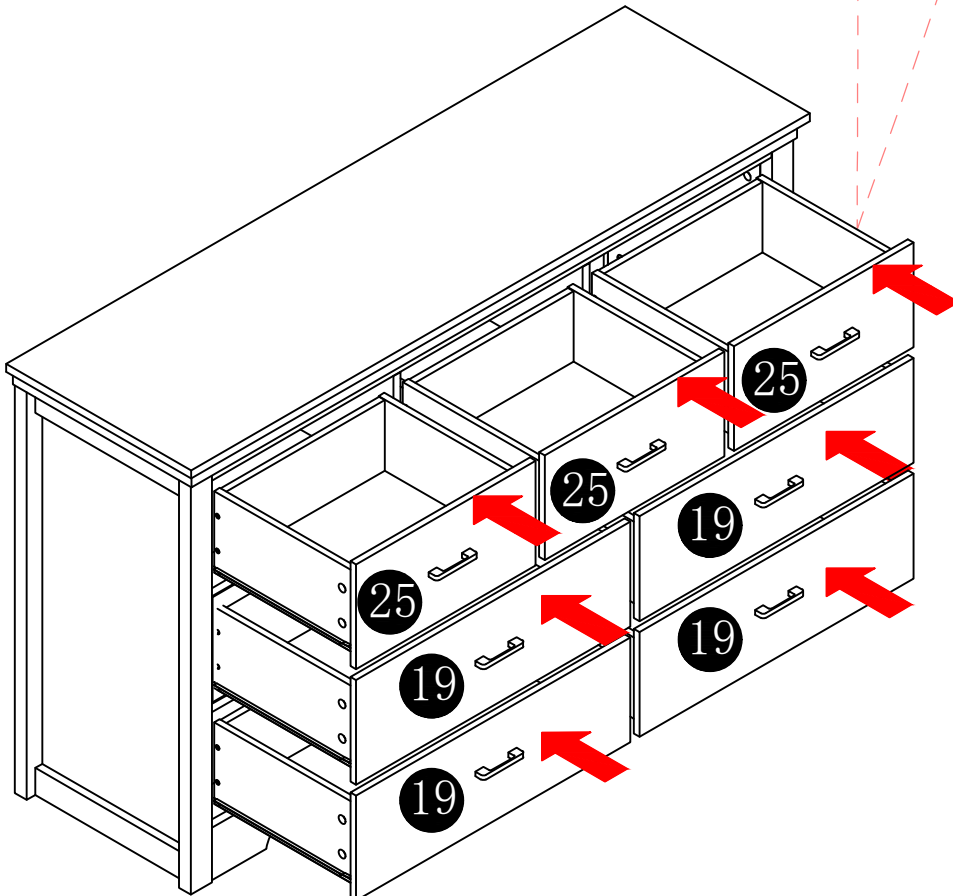

x7





Steps

36

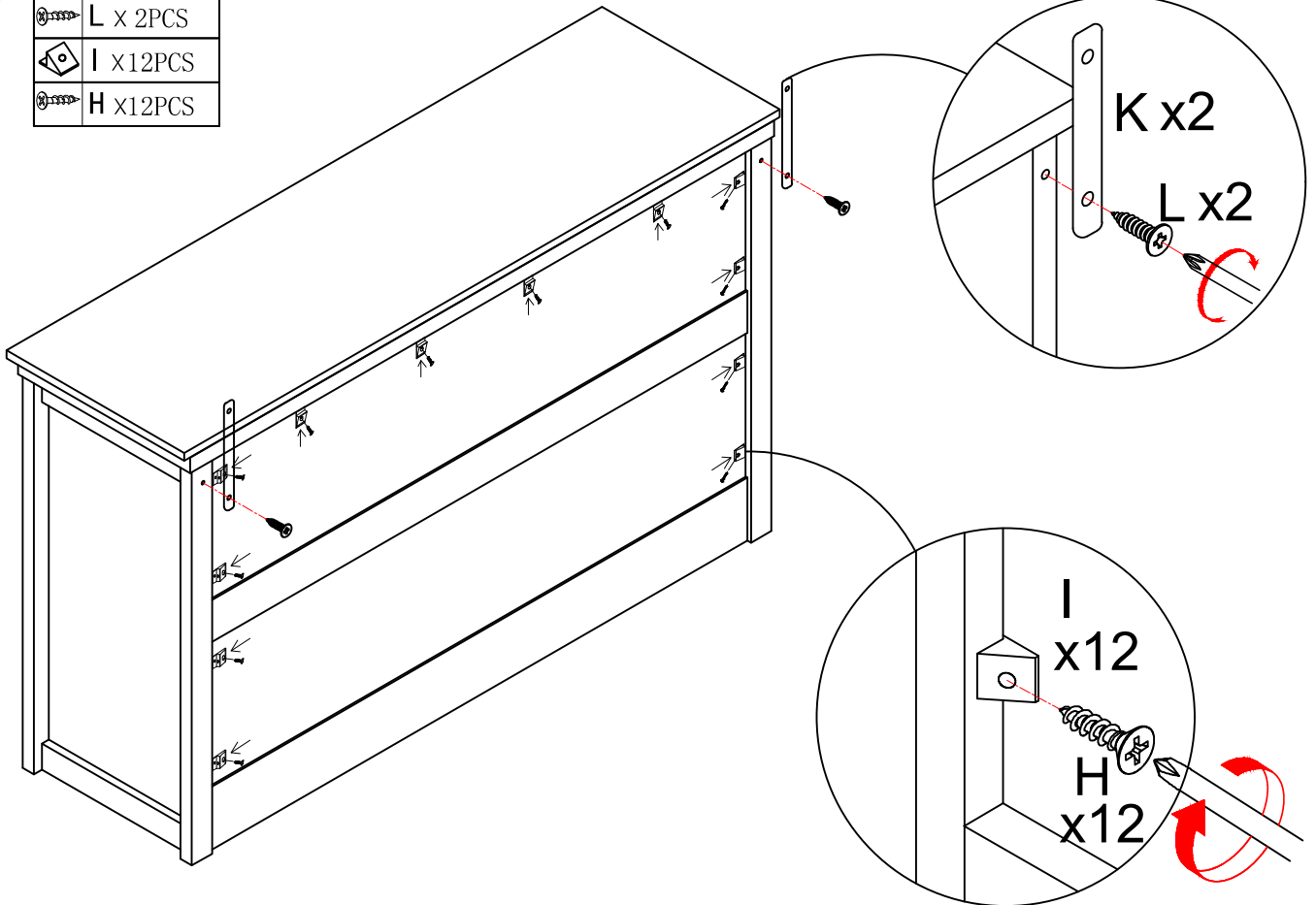
	K x 2PCS
	L x 2PCS
	I x 12PCS
	H x 12PCS



37

	M x 2PCS
	E x 2PCS

