

Installation&Operation Manual

Varminpool

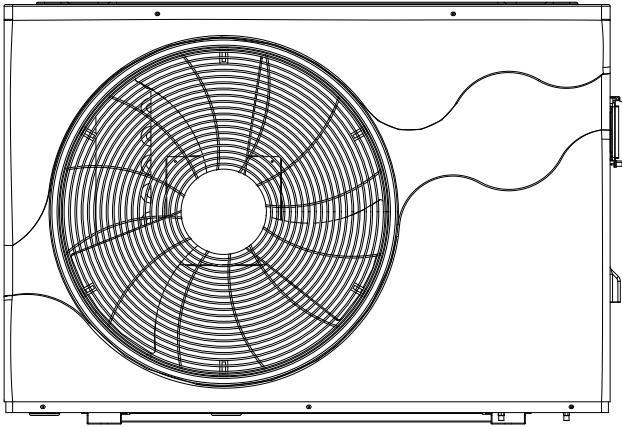

Customer Service Email: varminpool_service@163.com

Customer Service Phone: (978) 736-6880

(Our customer service working hours are from 9 a.m. to 6 p.m. Eastern Time)

Thank you very much for purchasing our product, please keep this installation manual carefully and read this manual carefully before you install heat pump.

CATALOGUE

1. DESCRIPTION	1
1.1 Product Dimensions	1
1.2 Exploded View	2
2. INSTALLATION	3
2.1 Package Listing	3
2.2 Warning	4
2.3 Installation Instructions	6
2.4 Electrical Installation	8
2.5 Start-up And Initialization Issues	9
3. USE	11
3.1 Interface Introduction	11
3.2 Advanced Setting	11
3.3 Icon List	12
3.4 Advanced Setting	13
4. REPAIRS	16
5. SCHEMATIC DIAGRAM	18
6. PARAMETER TABLE	20

1.DESCRPTION

1.1 Product Dimensions

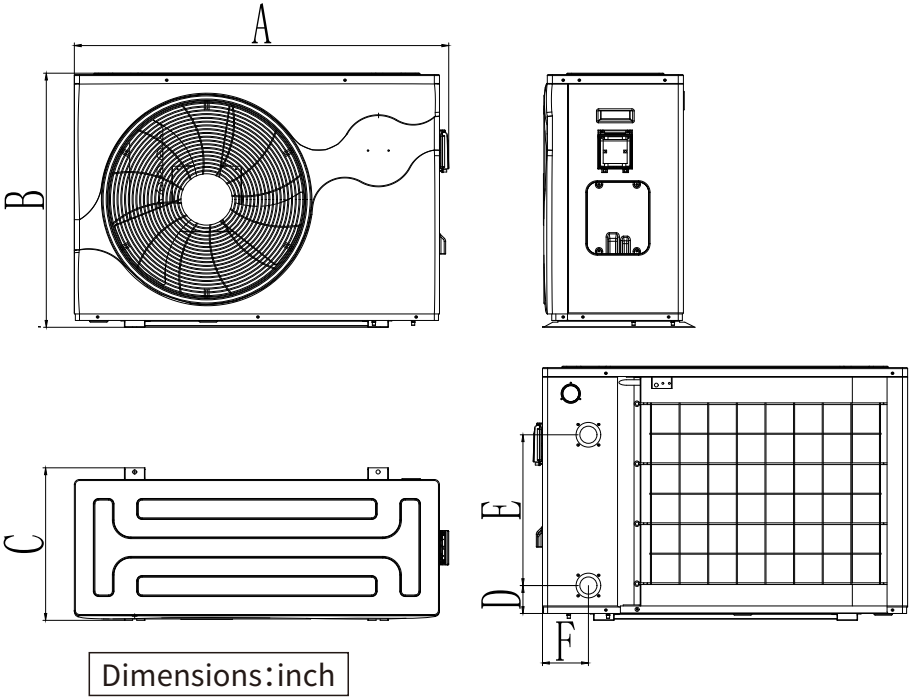

Model	KSPF-025L1VUA3	KSPF-030L1VUA3	KSPF-035L1VUA3
A	43.00	43.00	43.00
B	29.21	29.21	29.21
C	17.52	17.52	17.52
D	3.21	3.21	3.21
E	17.32	17.32	17.32
F	5.28	5.28	5.28
Water Inlet	1.5"	1.5"	1.5"
Water Outlet	1.5"	1.5"	1.5"

1.2 Exploded View

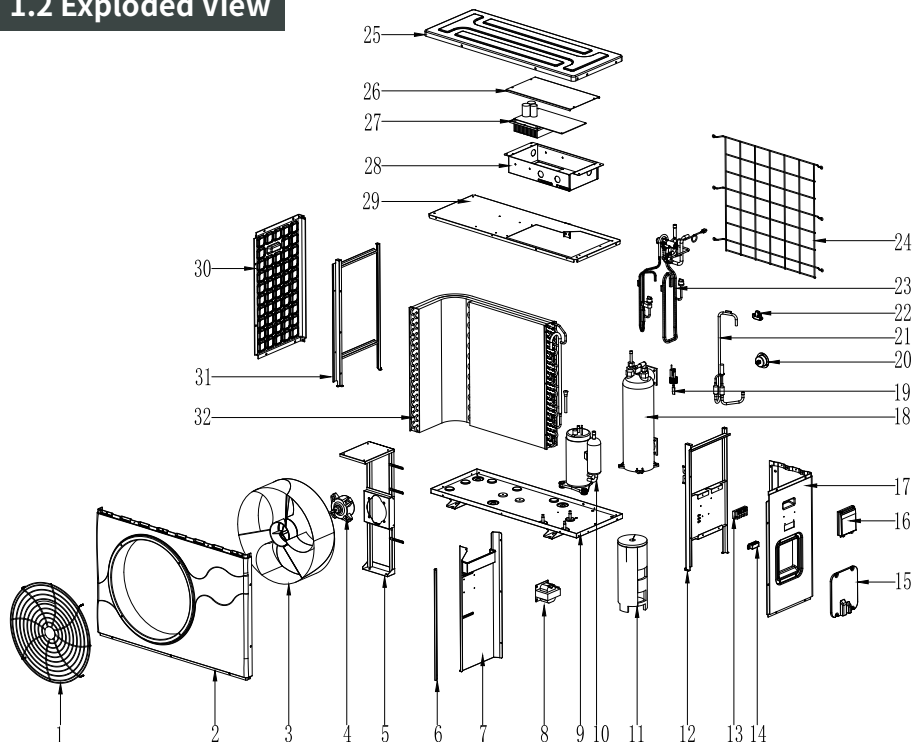

1.Fan Guard	9.Base Plate Assembly	17.Right Panle	25.Top Cover
2.Front Panle	10.Compressor	18.Heat Exchange	26.Electrical Box Cover
3.Fan Blade	11.Compressor Acoustic Material	19.Water Flow Switch	27.Main Board
4.Fan Motor	12.Right Panle Support	20.Pressure Gauge	28.Electrical Box
5.Fan Support	13.Terminal Block	21.EEV Assembly	29.Top Frame Assembly
6.Front Panle Support	14.Wire Fixing Clip	22.Ambient Temperature Support	30.Left Panle
7.Middle Partition Plate	15.Terminal Box Cover	23.4-way Valve	31.Left Panle Support Assembly
8.Reactor	16.Controller Waterproof Box	24.Rear Protective Net	32.Evaporator Assembly

2.INSTALLATION

2.1 Package Listing

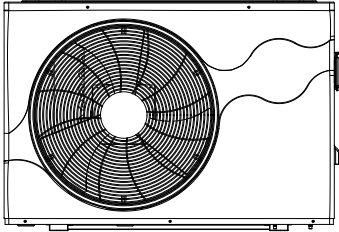

Heat Pump Unit(1 PCS)



Instruction Guide(2 PCS)

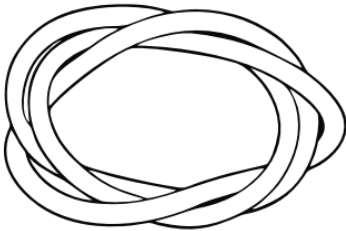

Condense Water Draining Hose(2 PCS)

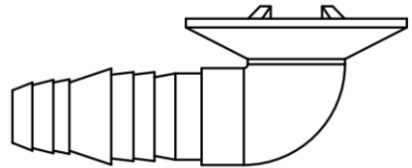

Condense Water Draining Fitting(2 PCS)

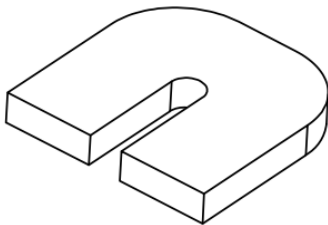

Rubber Shock Absorption Pad(4 PCS)

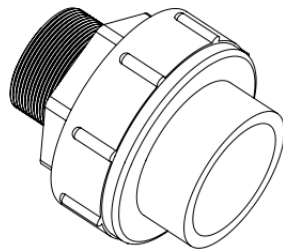

PVC Pipe adapter(2 PCS)

2.2 Warning

WARNING:

This heat pump uses R32 refrigerant, which is flammable.

No work on the refrigerant circuit may be performed by unauthorized personnel.

The following safety measures must be implemented before servicing or repairing the refrigerant circuit to ensure safe execution.

2.2.1 Working procedure

1. Notify all personnel in the vicinity about the work being performed.
2. DO NOT work in confined spaces.
3. Clearly mark and secure the work area. Pay special attention to marking areas near potential ignition sources or open flames.

2.2.2 General work area

1. Before and during maintenance, you MUST use an appropriate refrigerant detector to verify the absence of flammable gas.
2. Ensure the leak detection system installed on the unit is:
Compatible with flammable refrigerants, Spark-free, and Sealed or intrinsically safe.

2.2.3 Refrigerant presence check

R32 refrigerant is classified as an A2L class mildly flammable gas. Leak detection operations must be performed by qualified personnel in well-ventilated areas, free from open flames or potential ignition sources.

2.2.4 Fire extinguisher access

If hot work on the refrigerant system or its components is required, fire extinguishing equipment must be immediately available. Place dry chemical or CO₂ fire extinguishers near the work area.

2.2.5 Ignition source elimination

Before starting fire hazard elimination:

1. Survey the work area.
2. Display "NO SMOKING" signs prominently.

2.2.6 Ventilation protocol

Before starting system maintenance or hot work:

1. Confirm the work area is outdoors or well-ventilated.
2. Maintain adequate ventilation throughout the operation.

2.2.7 Flammable refrigerant system checks

When replacing electrical components:

- Use ONLY manufacturer-approved parts to ensure compatibility and safety.
- Consult manufacturer technical support if uncertain.

For systems using flammable refrigerant, perform these inspections:

- a. Confirm refrigerant charge suitability for the equipment installation room.
- b. Verify ventilation openings and air vents are operational and unobstructed.
- c. For indirect refrigeration circuits, inspect secondary circuits.
- d. Equipment labels and safety markings **MUST** remain legible. Replace illegible labels.
- e. Position refrigerant piping and components to avoid contact with corrosion-causing substances.



NO open flames
within the unit.



Use the heat pump in
an open environment.

2.3 Installation Instructions

2.3.1 Heat pump unit installation

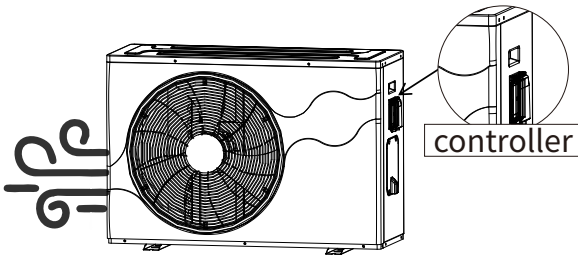

The heat pump has 25-inch of unobstructed surroundings and 60-inch of unobstructed air outlets

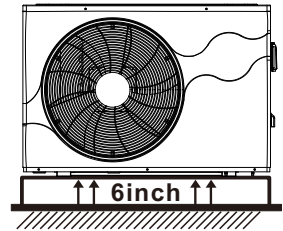

The heat pump shall be mounted on a 6-inch elevated base with rubber anti-vibration pads installed between all unit feet and foundation.

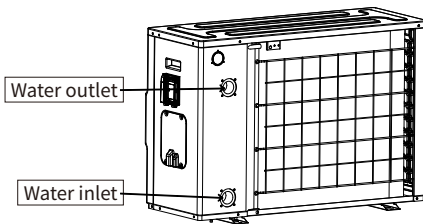

Install adapters at the inlet and outlet of the back of the heat pump.

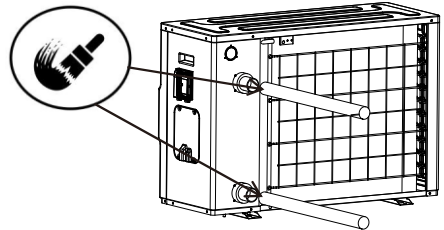

Brush the connecting tube with sealing glue and connect it to the adapter.

2.3.2 Swimming pool system installation

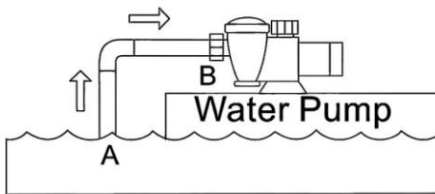

Step 1: Connect the swimming pool and water pump with a water pipe, with water flow direction A to B.

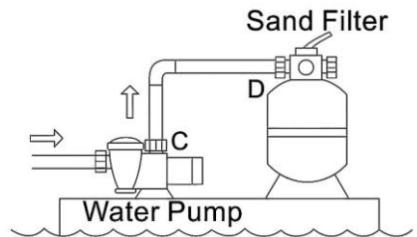

Step 2: Connect the water pump outlet to the sand filter inlet, with water flow direction C to D.

220-240V/60Hz

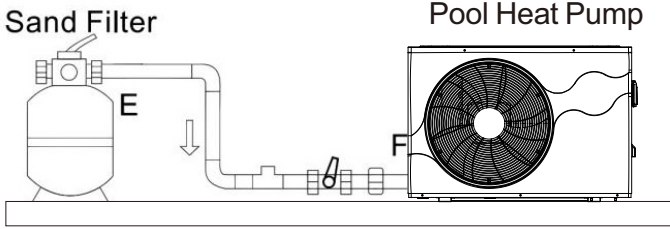

Step 3: Connect the outlet of the sand filter to the inlet of the swimming pool heat pump. The direction of water flow is from E to F.

220-240V/60Hz

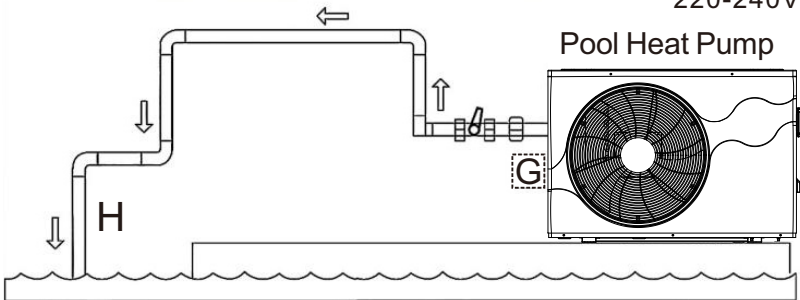

Step 4: Connect the outlet of the pool heat pump to the pool. The direction of water flow is from G to H.

220-240V/60Hz

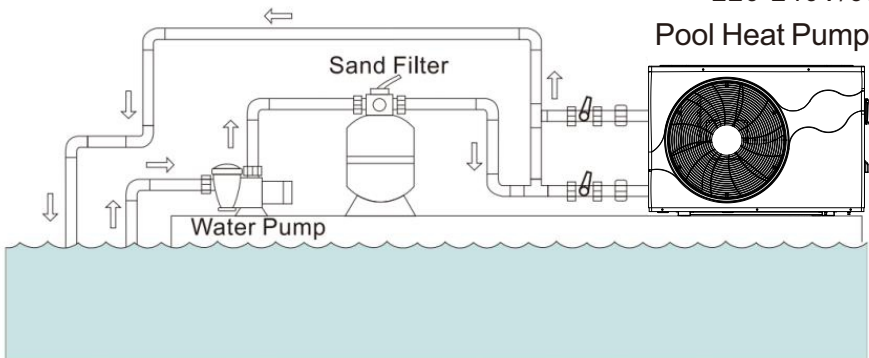

As shown in the above figure, the installation has been completed.

2.4 Electrical Installation

WARNING:

Please connect the heat pump to the electrical system according to the following instructions. The heat pump should be connected to D-type circuit breaker (see Table2-1) . Comply with the current standards and regulations of the country where the system is located. Power cables must be selected based on the unit's rated power and the cable length required for installation (see table below). Additionally, cables must be suitable for outdoor use.

Model	Powersupply	Max-current	Cable diameter	Earth Leakage Circuit Breaker	FUSE
KSPF-025L1VUA3	220-240V/60Hz	24.5A	3*10AWG	35A	30A
KSPF-030L1VUA3		33.5A	3*10AWG	45A	30A
KSPF-035L1VUA3		33.5A	3*10AWG	45A	30A

Table 2-1

Step 1: Remove the electrical side panel with a screwdriver to access the terminal block.

Step 2: Connect the power cables to the heat pump according to the terminal labels provided with the unit (BK-L1, RD-L2, GN-G).

Step 3: Connect the power cables to the terminal block as shown in the figure below.

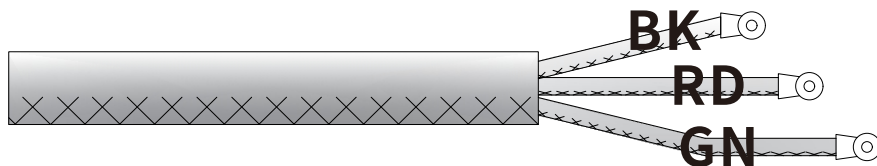

Step 4: Close the electrical side panel of the heat pump.

CAUTION: The interlock control wiring for the circulation pump. Must be coordinated with the manufacturer's technicians based on the installation type. Ensure outdoor electrical components are waterproof.

2.5 Start-up And Initialization Issues



To improve swimming pool heating efficiency, adding a thermal cover is recommended.

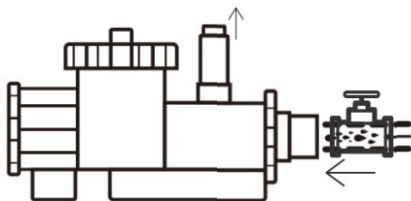

To facilitate maintenance and flow control, a valve should be installed on the pump inlet pipe. The recommended flow rate :
KSPF-025L1VUA3 is 3000-4000 GPH.
KSPF-030L1VUA3 is 4500-5500 GPH.
KSPF-035L1VUA3 is 4500-5500 GPH.

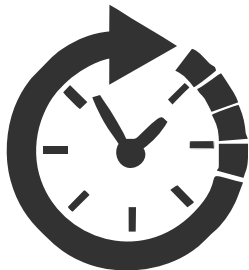

The initial heating process requires 48-72 hours. Please allow normal operation during this period and refrain from turning off the unit.

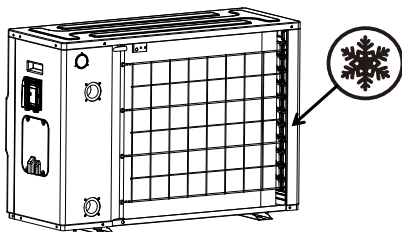

Frost may form on the unit during heating operation. This is normal. The unit will automatically initiate the defrost cycle. Do not power off the unit.

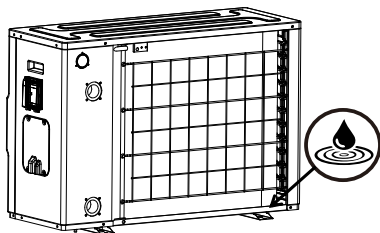

During heating operation, condensate will form. Ensure the condensate drain line is properly connected.





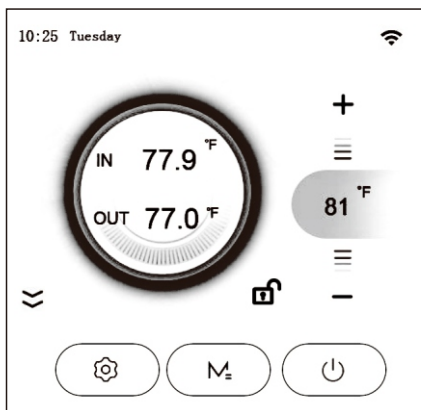

Frequently Asked Questions	Root Cause Analysis	Troubleshooting Solutions
The controller displays Error Code E03	Incorrect Startup Sequence	1.Start the circulation pump first. 2. Confirm water flow from the pool return line. 3. ONLY THEN power on the heat pump.
	Water Circuit Restriction Detected	1. Verify water circuit valves are fully open. 2. Confirm normal water intake at the pool. 3. Check proper water discharge operation.
	Water Circuit Reversed Flow	Verify correct water flow direction. Refer to Section 2.3.
Frost accumulation detected on the blue evaporator of the heat pump.	Normal phenomenon	Maintain power supply - The unit features intelligent defrost control. Contact manufacturer technical support if frost persists beyond 120 minutes.
The wired controller for no display or indicator lights immediately after power-on.	Verify no power output from the power supply unit.	Check the Power Supply Unit for abnormal conditions.
circuit breaker tripped	Installation on a shared circuit with other equipment risks over loading. Provide a dedicated branch circuit immediately.	Verify the air source heat pump connects exclusively to a dedicated circuit breaker with no other loads.
	The circuit fails to meet the unit's maximum current requirements due to undersized wiring or incompatible circuit breaker ratings.	Upgrade wiring and breaker to meet the unit's maximum current requirements
The heat pump prolong heating time and reduce heating capacity.	Heating cycles abnormally short	The initial heating period for a newly filled pool typically requires 48 to 72 hours when using a heat pump system.
	Excessive heat loss occurs in the pool due to lack of insulation, specifically from being left uncovered	Procure a high-efficiency thermal cover.
	The pump flow rate exceeds design specifications, resulting in excessive flow velocity.	Reduce the flow rate of the water pump, Decrease the flow rate of the water pump, The recommended flow rate : KSPF-025L1VUA3 is 3000-4000 GPH. KSPF-030L1VUA3 is 4500-5500 GPH. KSPF-035L1VUA3 is 4500-5500 GPH.
	The environmental humidity is too high and there is frequent frosting	Place the heat pump in a dry place.
	The swimming pool is too large, but the heat pump is too small.	Be patient and reduce the pool water volume.
	The ambient temperature is too low, resulting in a decrease in the heating performance of the heat pump.	Be patient and reduce the pool water volume.
Water is overflowing from the bottom	Normal phenomenon	Inspect the water leakage location. Note that condensate forms normally during unit heating operation.

3.USE





















3.1 Interface Introduction



3.2 Function Icon Definition

Icon	Definition	Description&Operation
	Lock/Unlock Key	Tap to toggle lock/unlock status. The controller automatically locks after 60 seconds of inactivity.
	Power On/Off Key	1.In the unlocked state, press and hold for 1 second to turn the device on/off. 2.When powered off, the icon appears gray. 3.When powered on, the icon turns red (heating mode), blue (cooling mode), or yellow (auto mode).
	Model	1.When unlocked and powered on, briefly press the button to cycle through 7 available operating modes. 2.When unlocked and powered on, press and hold for 5 seconds to switch the temperature display unit between Celsius (°C) and Fahrenheit (°F).
	Function Key	Unlocked State, press the button to enter the function menu. Function Menu Includes: PROGRAM、SETTING、TIME、ERROR、WIFI
	Up Key	1.When the device is unlocked and powered on, briefly press the button to enter temperature setting mode. 2.Each press increases the value by 1.
	Down Key	1.When the device is unlocked and powered on, briefly press the button to enter temperature setting mode. 2.Each press decreases the value by 1.

3.3 Icon List

Icon	State	Definition
	OFF	Powered OFF or Non-Heating Mode
	ON	Powered ON and Heating Mode
	OFF	Powered OFF or Non-Cooling Mode
	ON	Powered ON and Cooling Mode
	OFF	Powered OFF or Non-Auto Mode
	ON	Powered ON and Auto Mode
	ON	Silent Mode
	ON	Smart Mode
	ON	Boost Mode
	FLASHING	Wi-Fi Pairing Status
	ON	Wi-Fi Connected
IN	ON	Water Inlet
OUT	ON	Water outlet
	ON	°C Display
	ON	°F Display
	ON	Frost Protection Mode
	ON	Powered On - Defrosting
	ON	Fault Alarm
	ON	Button Lock Status
	ON	Water Pump Running
	ON	Compressor Running
	ON	Fan Running
	ON	4-way Valve Switch On

3.4 Advanced Setting

3.4.1 Mode Setting and Display

From the unlocked main interface, repeatedly press the "M" button to cycle through all 7 operating modes, which include Heating, Cooling, and Auto mode:

Silent Heat Mode: "☀️ + 🟩"; Smart Heat Mode: "☀️ + 🟨"; Boost Heat Mode: "☀️ + 🟨"
 Mode: "☀️ + 🟩". Silent Cool Mode: "❄️ + 🟩"; Smart Cool Mode: "❄️ + 🟨";
 Boost Cool Mode: "❄️ + 🟨"; Auto Mode: "🔄".

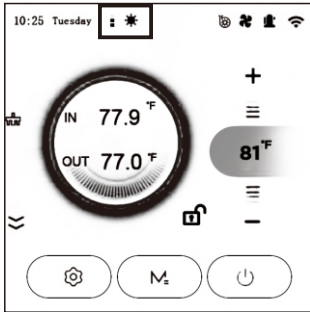

Heating Mode (Red Interface)

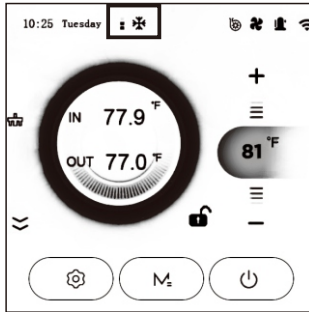

Cooling Mode (Green Interface)

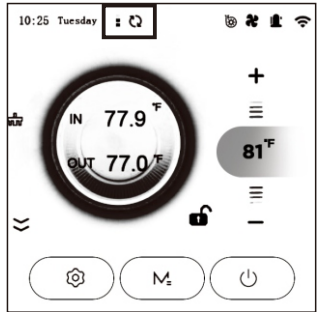

Auto Mode (Yellow Interface)

3.4.2 Time Setting

Main Interface press "⚙️" → "🕒 (TIME)", enter Time Setting Interface, set date and time.

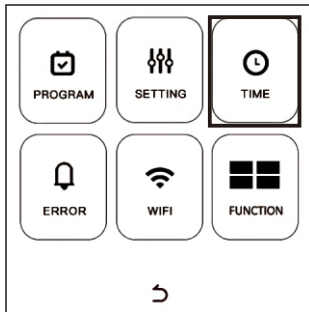
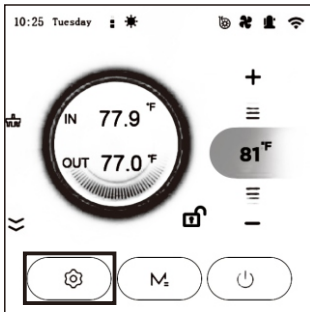

3.4.3 Timer Setting

Main Interface press "⚙️" → "🕒 (TIME)" → "⬇️", enter Time Setting Interface. Tap the corresponding time slot to activate the scheduled start function (3 time slots available).



3.4.4 Manual Defrost Function

Main Interface press "⚙️" → "🗄️ (FUNCTION)" → "DEFORS". Press "DEFROST" to initiate defrosting.

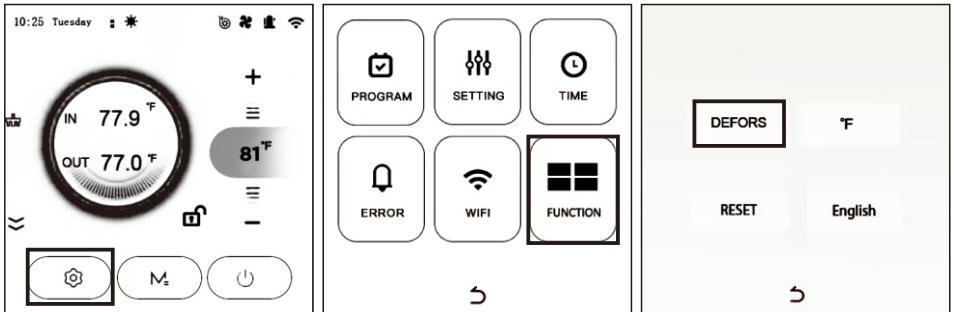

3.4.5 °F/°C Switch

Main Interface press "⚙️" → "🗄️ (FUNCTION)" → "°F/°C". Press "°F/°C" to switch.

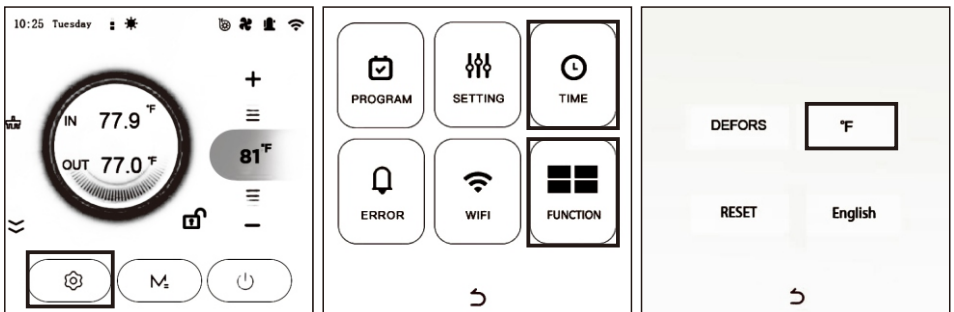

3.4.6 WIFI Match

Main Interface press "⚙️" → "📶 (WIFI)".

For app download and usage instructions, please refer to the Wi-Fi Operation Manual.

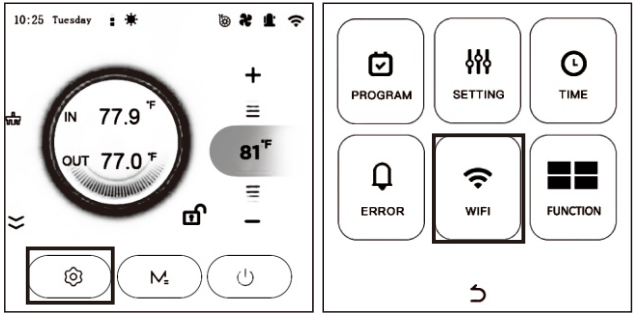

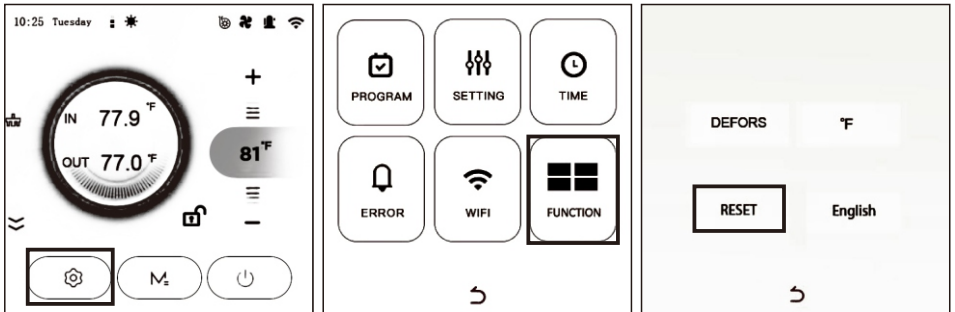

3.4.7 Restore Factory Settings

In the powered-off and unlocked state, Main Interface press "⚙️" → "🗄️ (FUNCTION)" → " (Reset)".



4.REPAIRS

When a unit fault occurs, a fault icon and the corresponding fault code are displayed on the top of the main interface. Main Interface press "  " → " ERROR " Check Fault History.Press and hold the "  " for 2 seconds to clear the fault records.

Code	Description	Reason&Solution
E03	Flow Failure	<ol style="list-style-type: none"> 1.Clogged water filter. Clean water circuit. 2.Insufficient pump head. Replace pump flow . 3.Incorrect pump wiring/direction.Verify rotation and electrical connections. 4.Flow switch directional error.Align arrow with flow direction. 5.Intermittent/disconnected flow switch wiring.Secure terminal connections.
E04	Frost Protection	The heater will not start up when ambient temperature is too low. This is a normal protective function.
E05	High Pressure Protection	<ol style="list-style-type: none"> 1. The wiring of the high-pressure switch is either loose or incorrect. 2. There is too much refrigerant in the system, fill according to the nameplate requirements. 3. The unit has no water flow or low flow rate. Check the water pump and water flow. 4. Air is introduced into the fluorine circuit system. Vacuumize and refill with refrigerant. 5. There is a blockage in the filter and throttle valve on the refrigerant side. 6. There is scaling phenomenon in the water side heat exchanger. Clean the scale.
E06	Low Pressure Protection	<ol style="list-style-type: none"> 1. The wiring of the low-pressure switch is either loose or incorrect. Correct the wiring. 2. Lack of refrigerant or complete leakage of refrigerant. Check for leaks and refill refrigerant. 3. The fan is damaged and the unit is severely frosted. Check the fan wiring or replace the fan. 4. The refrigerant side filter or throttle valve is clogged. Replace accessories.
E09	Connection Failure Between Main Board And Controller	<ol style="list-style-type: none"> 1. Verify any poor connection in the communication wiring between the Wired Controller and Main Control Board.
E10	Connection Failure Between Main Board And Driver Board	<ol style="list-style-type: none"> 1. Verify any poor connection in the communication wiring between the Driver Board and Main Control Board.

E12	High Exhaust Temperature	<ol style="list-style-type: none"> 1. Refrigerant System Blockage 2. Insufficient Refrigerant Charge or Faulty Sensor in the refrigerant circuit.
E15	Water Inlet Temperature Sensor Fault	<ol style="list-style-type: none"> 1. Sensor wiring disconnected or short-circuited 2. Failed sensor 3. Damaged mainboard port
E16	Coil Temperature Sensor Fault	<ol style="list-style-type: none"> 1. Sensor wiring disconnected or short-circuited 2. Failed sensor 3. Damaged mainboard port
E18	Exhaust Temperature Sensor Fault	<ol style="list-style-type: none"> 1. Sensor wiring disconnected or short-circuited 2. Failed sensor 3. Damaged mainboard port
E21	Ambient Temperature Sensor Fault	<ol style="list-style-type: none"> 1. Sensor wiring disconnected or short-circuited 2. Failed sensor 3. Damaged mainboard port
E23	Chilled Water Outlet Temperature Too Low	<ol style="list-style-type: none"> 1. Insufficient water flow → Check for blockages in the water circuit or verify that the water pump is operating normally. 2. Loose or detached inlet/outlet temperature probe → Reinstall the temperature probe securely in the correct position.
E27	Outlet Water Temperature Sensor Fault	<ol style="list-style-type: none"> 1. Sensor wiring disconnected or short-circuited 2. Failed sensor 3. Damaged mainboard port
E29	Suction Temperature Sensor Fault	<ol style="list-style-type: none"> 1. Sensor wiring disconnected or short-circuited 2. Failed sensor 3. Damaged mainboard port
E32	Vast temperature variations between inlet and outlet	<ol style="list-style-type: none"> 1. Check for blockages in the water circuit or verify normal pump operation if water flow is insufficient. Reposition any loose or dislodged inlet/outlet temperature sensors.
E33	Refrigeration Outer Coil Overtemperature	<ol style="list-style-type: none"> 1. Poor Heat Dissipation 2. Refrigeration System Problems 3. System Blockage 4. Four-Way Valve Failure
E42	Indoor Coil Temperature Sensor Fault (Cooling Coil)	<ol style="list-style-type: none"> 1. Sensor wiring disconnected or short-circuited. 2. Failed sensor. 3. Damaged mainboard port.
Err46	DC Fan 1 Fault	Fan Drive Board or Motor Failure

5. SCHEMATIC DIAGRAM

Model:KSPF-025L1VUA3

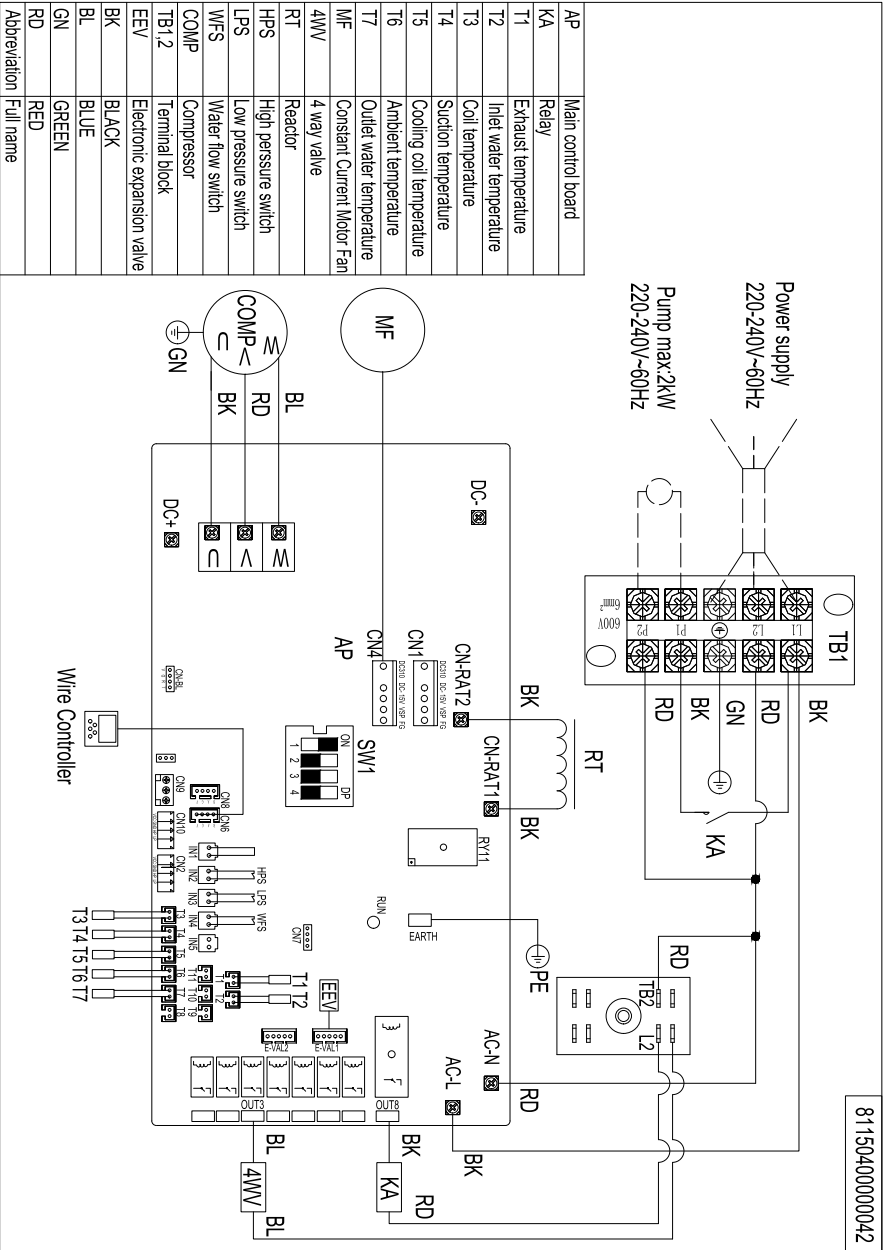

AP1	Main control board
AP2	Filter power board
AP3	Compressor drive plate
KA	Relay
T1	Exhaust temperature
T2	Inlet water temperature
T3	Coil temperature
T4	Suction temperature
T5	Cooling coil temperature
T6	Ambient temperature
T7	Outlet water temperature
MF	Constant Current Motor Fan
4WV	4 way valve
HPS	High perssure switch
LPS	Low perssure switch
WFS	Water flow switch
COMP	Compressor
TB1.2	Terminal block
EEV	Electronic expansion valve
WH	WHITE
BL	BLACK
GN	GREEN
RD	RED
Abbreviation	Full name

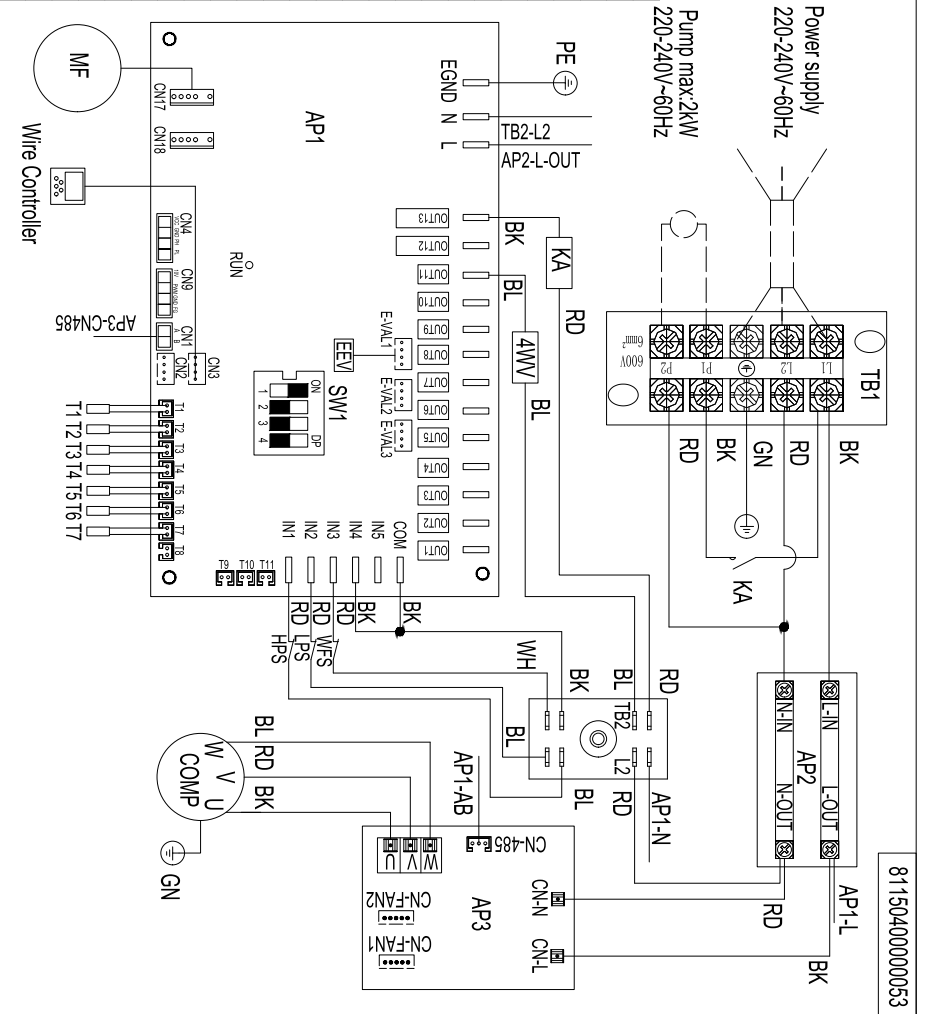

81150400000053

6. PARAMETER TABLE

Air-source Swimming Pool Heat Pump		
Model		KSPF-025L1VUA3
80°F Air 80°F Water 63%RH	Heating capacity(Btu/h)	23200~90000
	Power input(Btu/h)	1467~13500
	COP	6.60~12.50
50°F Air 80°F Water 63%RH	Heating capacity(Btu/h)	18700~73400
	Power input(Btu/h)	2460~15100
	COP	4.80~7.10
Power supply		220-240V~60Hz
Max power input(Btu/h)		17700
Max current(A)		24.5
Setting temperature range(Heating)		46°F~104°F
Setting temperature range(Cooling)		46°F~82°F
Running(Air) temperature range		5°F~110°F
Refrigerant type/quantity (Oz)		R32/45.9
Air side heat exchanger		Hydrophilic fin exchanger
Water side heat exchanger		Titanium tube heat exchanger
Water flow(gpm)		49.9
Net dimension L×W×H (inch)		43.0×17.5×29.2
Packing dimension L×W×H (inch)		47.6×20.3×32.8
Net weight (lbs)		152
Packing weight(lbs)		176.37
Maximum working pressure of heat exchanger		4.4MPa
Maximum working pressure of exhaust side		2.5MPa
Maximum working pressure of suction side		4.4MPa
Waterproof grade		IPX4
Noise		47~58dB(A)

Air-source Swimming Pool Heat Pump		
Model		KSPF-030L1VUA3
80°F Air 80°F Water 63%RH	Heating capacity(Btu/h)	30000~105000
	Power input(Btu/h)	1910~15800
	COP	6.60~12.30
50°F Air 80°F Water 63%RH	Heating capacity(Btu/h)	21800~76000
	Power input(Btu/h)	2870~15700
	COP	4.80~7.10
Power supply		220-240V~60Hz
Max power input(Btu/h)		24740
Max current(A)		33.5
Setting temperature range(Heating)		46°F~104°F
Setting temperature range(Cooling)		46°F~82°F
Running(Air) temperature range		5°F~110°F
Refrigerant type/quantity (Oz)		R32/49.4
Air side heat exchanger		Hydrophilic fin exchanger
Water side heat exchanger		Titanium tube heat exchanger
Water flow(gpm)		58.0
Net dimension L×W×H (inch)		43.0×17.5×29.2
Packing dimension L×W×H (inch)		47.6×20.3×32.4
Net weight (lbs)		176
Packing weight(lbs)		200.62
Maximum working pressure of heat exchanger		4.4MPa
Maximum working pressure of exhaust side		2.5MPa
Maximum working pressure of suction side		4.4MPa
Waterproof grade		IPX4
Noise		49~59dB(A)

Air-source Swimming Pool Heat Pump		
Model		KSPF-035L1VUA3
80°F Air 80°F Water 63%RH	Heating capacity(Btu/h)	30000~120000
	Power input(Btu/h)	1910~18200
	COP	6.60~12.30
50°F Air 80°F Water 63%RH	Heating capacity(Btu/h)	21800~87000
	Power input(Btu/h)	2870~17700
	COP	4.80~7.10
Power supply		220-240V~60Hz
Max power input(Btu/h)		24740
Max current(A)		33.5
Setting temperature range(Heating)		46°F~104°F
Setting temperature range(Cooling)		46°F~82°F
Running(Air) temperature range		5°F~110°F
Refrigerant type/quantity (Oz)		R32/49.4
Air side heat exchanger		Hydrophilic fin exchanger
Water side heat exchanger		Titanium tube heat exchanger
Water flow(gpm)		66.0
Net dimension L×W×H (inch)		43.0×17.5×29.2
Packing dimension L×W×H (inch)		47.6×20.3×32.4
Net weight (lbs)		176
Packing weight(lbs)		200.62
Maximum working pressure of heat exchanger		4.4MPa
Maximum working pressure of exhaust side		2.5MPa
Maximum working pressure of suction side		4.4MPa
Waterproof grade		IPX4
Noise		49~59dB(A)