

DECK TILES ASSEMBLY INSTRUCTION

IMPORTANT NOTE: Before assembling these Deck Tiles, please make sure the underlying surface is **LEVEL** and **CLEAN**. Clear away rocks and weeds. These Wood Tiles are **most easily installed over hard, flat surfaces** like concrete or decking.

1

Step 1: Find **Tile A** and **Tile B** with sides as illustrated in the picture.

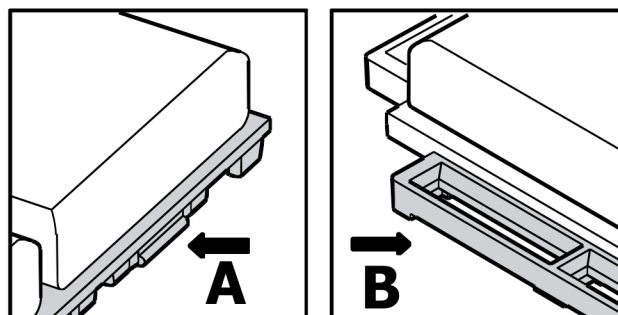

2

Step 2: Place tile A under the floor, align the sides of these tiles together, then tilt tile A at an angle of **30 degrees** with one hand.

*Remember to always hold the tiles at 30 degree angle during snapping.

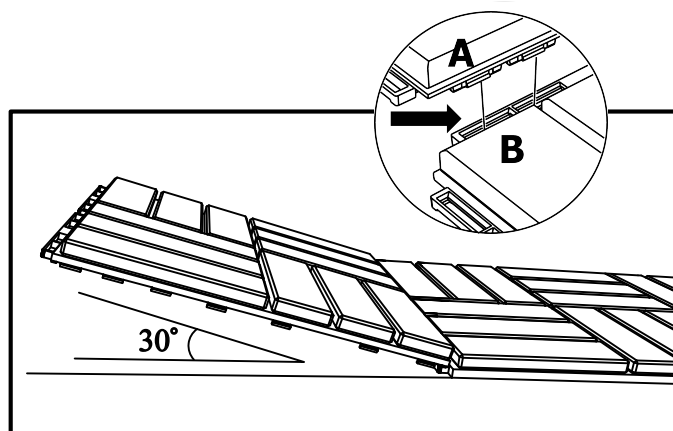

3

Step 3: Use the other hand or a rubber hammer to **firmly press** tile A down to connect correctly to the holes of tile B.

*When you hear a “clicking sound”, the tiles are snapped.

*When finished, you can easily trim the outer edges with a saw for a clean look.

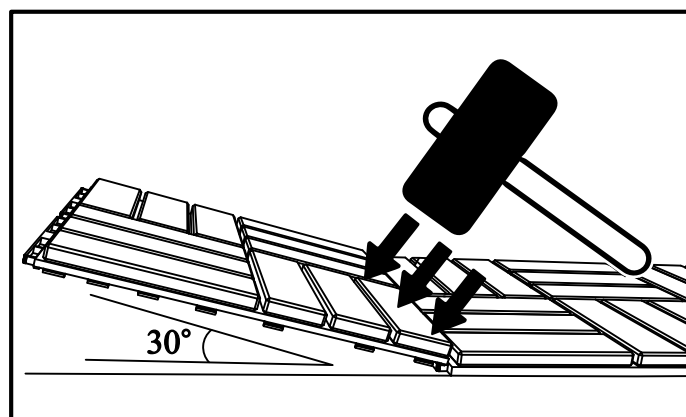

CLEANING & MAINTENANCE

Our Wood Deck Tiles are pre-treated with water-based wood oil ensure durability for outdoor use. However, wood is a natural material that ages and requires gradual clean and maintenance. The best way to extend the life of your Deck Tile is by cleaning them regularly, not leaving them outdoors unprotected more than necessary and re-staining them on a regular basis.

HOW TO CLEAN

It's easy to clean these Wood Deck Tiles. Simply use mild soap and water to clean the area. You can scrub the deck with a mop which has a sponge head to avoid scratching the Tiles. After mopping, rinse with a garden hose.

Leaves or other debris that fall between the gaps in the Tiles can usually be removed with a vacuum cleaner. If necessary, the tiles can be disassembled to clean underneath.

HOW TO MAINTAIN

You can easily refresh your Deck Tiles and enhance their durability by re-staining them regularly, for example, once a year. The frequency of re-staining Decking Tiles may vary depending on the climate you live in and the degree of exposure to sun and rain. Re-staining prevents the surface from drying out, cracking, and helps avoid moisture penetration into the wood

HOW TO RE-STAIN

Choose a place in the shade for cleaning, re-staining and leaving the Deck Tiles to dry. Avoid direct sunlight. Simply follow these steps to re-stain your Decking Tile:

1. Give the surface a thorough clean with mild soap and brush. Then wipe them dry or let them air dry for at least 24 hours. If wood fibers rise after cleaning, sand the surface with fine grade sandpaper. Be sure to sand them in the direction of the grain.
2. Give the chosen deck stain a good stir and apply a thin, even coat of stain to the surface using a brush, a roller or paint pads. Apply them on the entire surface at once and in the direction of the grain. Put some extra stains over any splits or cracks to help fill them in.
3. Only apply as much as the wood can easily absorb. Leave the surface to dry and apply further coats if needed.

HOW TO STORE

Disassemble and store your Deck Tiles during snowy season. Before storing, clean and let them dry thoroughly. If possible, store your Deck Tiles in a cool and dry indoor place. If stored outside, put them under a roof if possible or cover them with a protective cover. Allow air to ventilate, to avoid moisture and mold.

THANK YOU FOR CHOOSING US!

Our goal is to provide high quality outdoor furniture with outstanding customer service - all at an affordable price.