

ASSEMBLY INSTRUCTION

ITEM: N715P355011

DINING TABLE

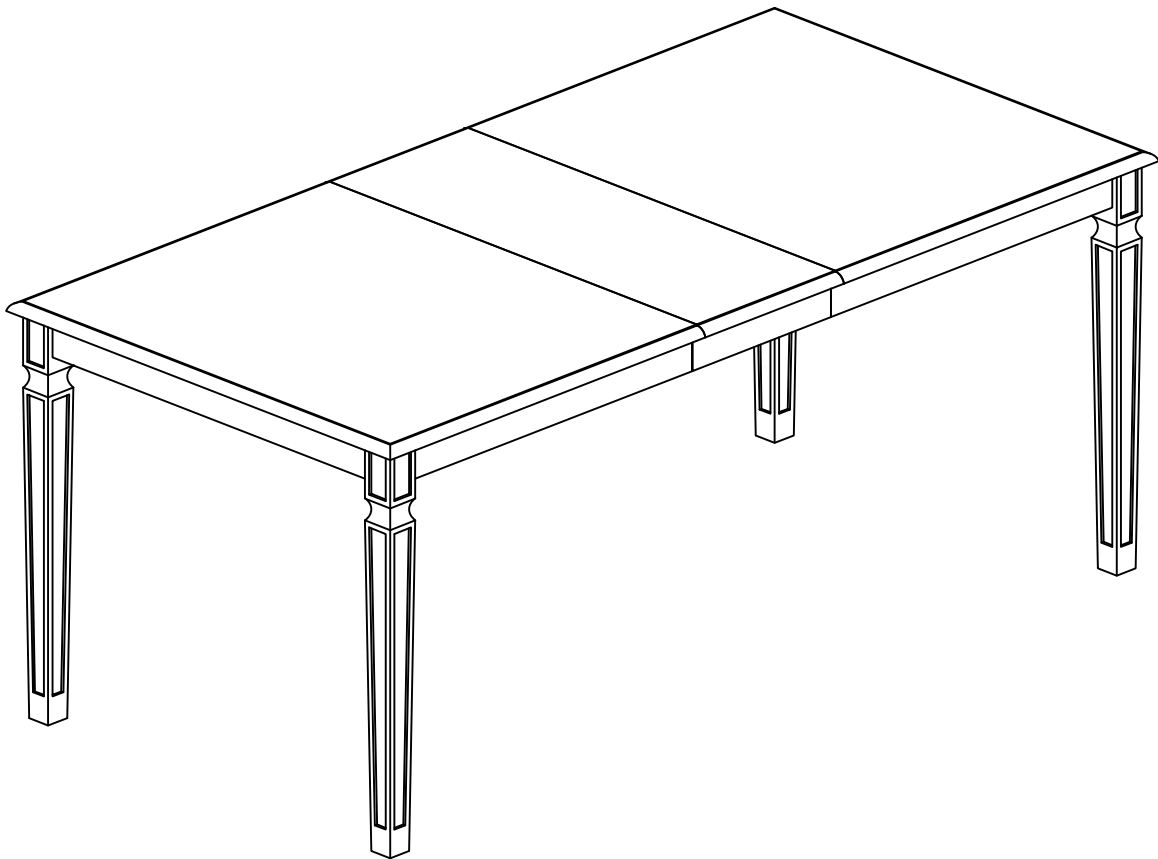

IMPORTANT NOTE :

- ① PLACE ALL PARTS ON A CLEAN AND SMOOTH SURFACE SUCH AS A RUG OR CARPET TO AVOID THE PARTS FROM BEING SCRATCHED.
- ② BEFORE YOU BEGIN , KINDLY FOLLOW THE ASSEMBLY INSTRUCTIONS STEP BY STEP.
- ③ DO NOT TIGHTEN ALL SCREWS AND BOLTS UNTIL THE TABLE IS FULLY SET-UP

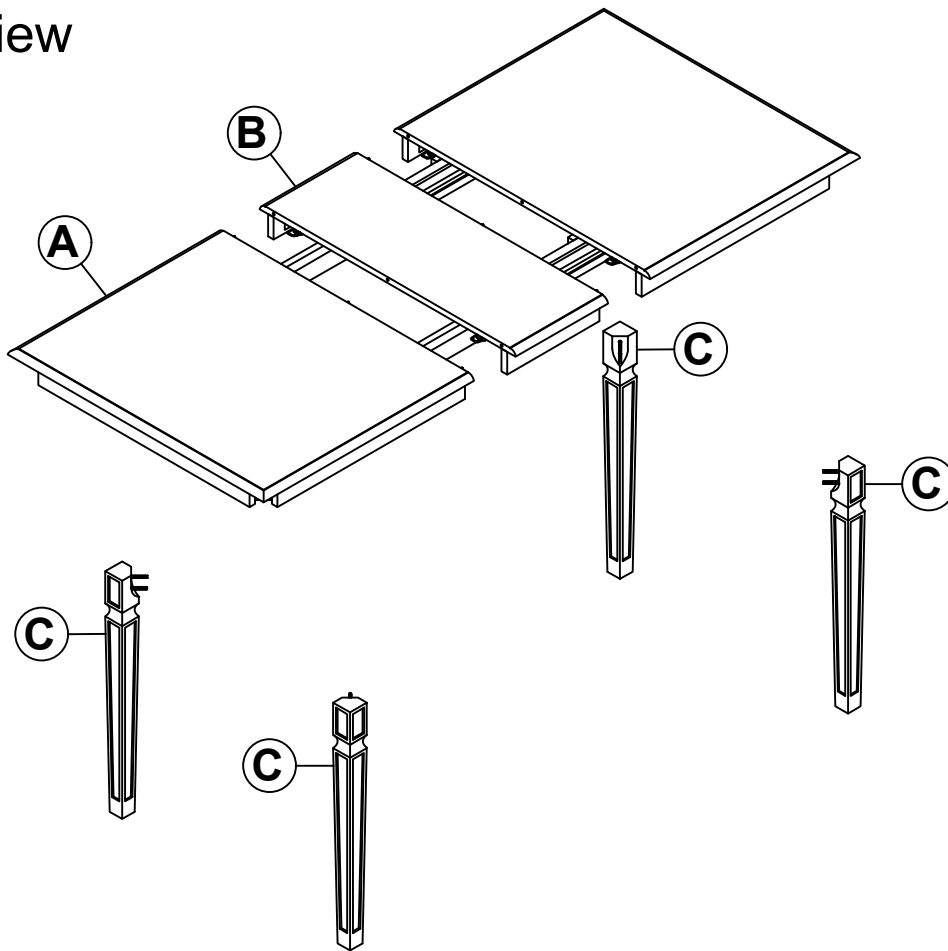

Detail view

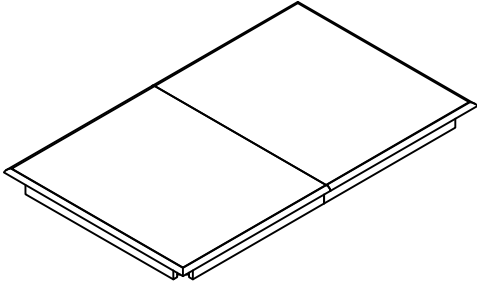
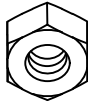
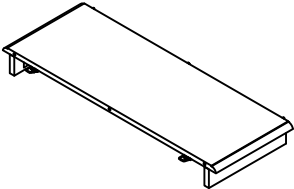
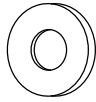
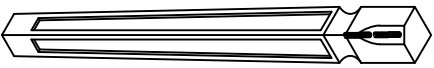
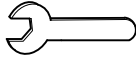

Part List	Hardware List
<p>A</p>  <p>Table Top (1pc)</p>	<p>1</p>  <p>Ø5/16" x 6mm Hex nut (8pcs)</p>
<p>B</p>  <p>Center Leaf (1pc)</p>	<p>2</p>  <p>Ø5/16" x 19mm x 1.5mm Flat Washer (8pcs)</p>
<p>C</p>  <p>Table Legs (4pcs)</p>	<p>3</p>  <p>90 x 12mm Open wrench (1pc)</p>

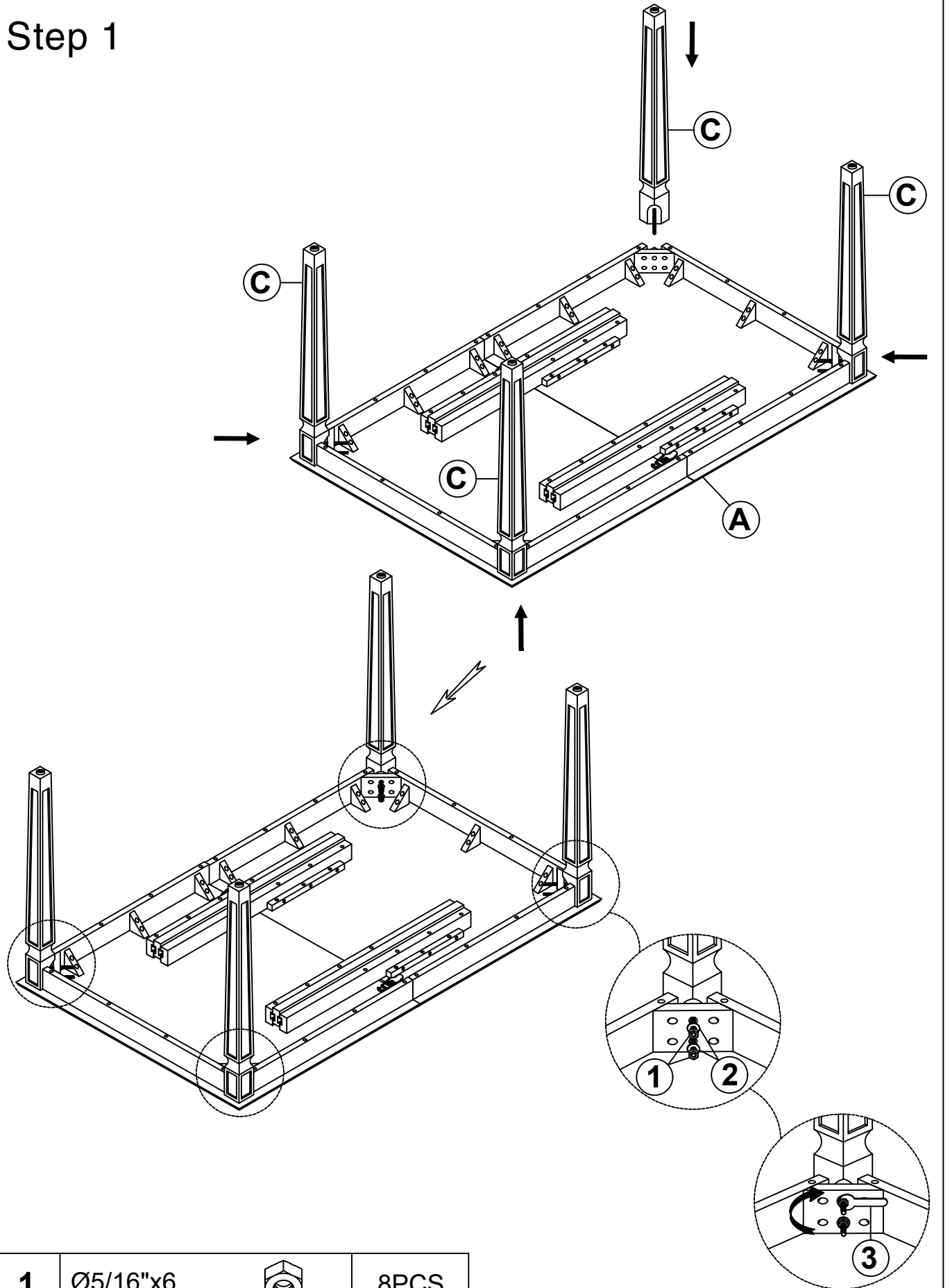
Step 1

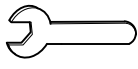

1	Ø5/16"x6		8PCS			
2	Ø5/16"x19x1.5		8PCS	3	90x12	
						1PC

Step 2

Unlock in these positions and pull the table top to either side.

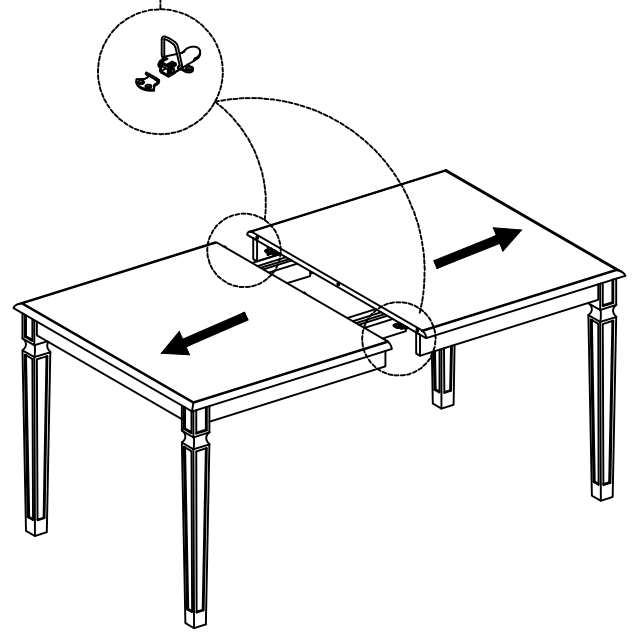
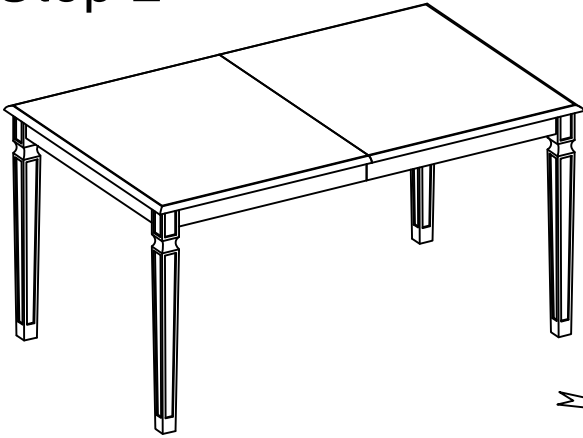

Place B in this position and align the drill holes accordingly then push the two table tops together.

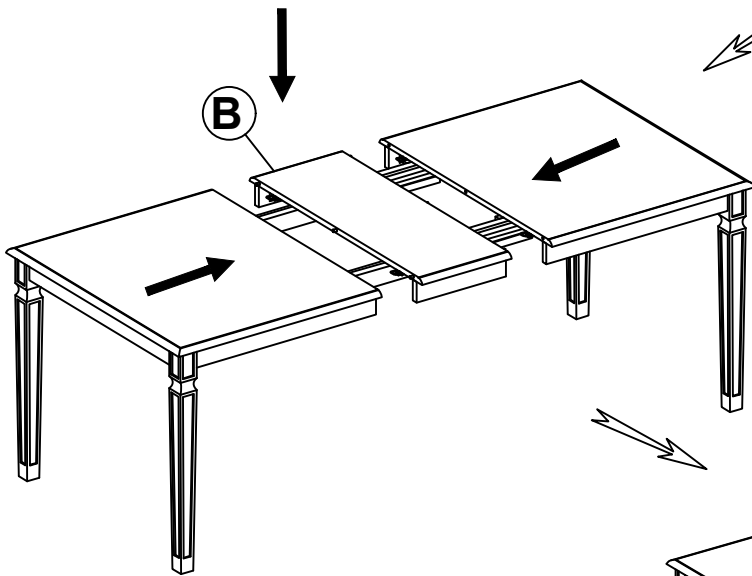

Hardware lock these positions.

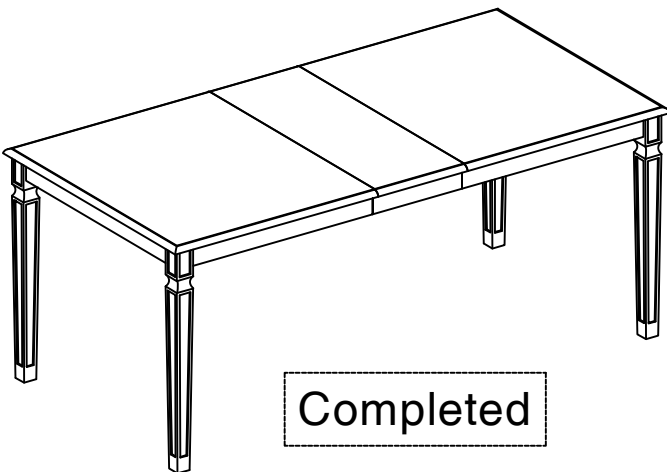
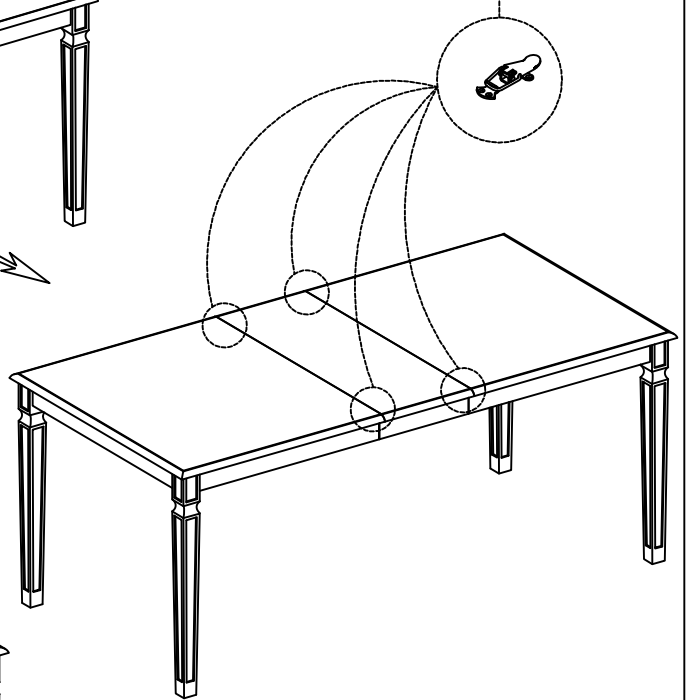

Completed