

Shown in Matte Black

Series	Fireclay
Material	Fireclay
Installation Type	Reversible Apron Front
Configuration	Single bowl
Overall Dimensions	30" x 18" x 10 1/8"
Bowl Dimensions	28 1/8" x 16 1/4" x 9 1/4"
Drain Size	3 3/4"
Finishes Available	Matte Black, Gloss White
Minimum cabinet size	30"
Template Included	No
Clips Included	No
Drain Location	Center
Accessories Included	Strainer



ACCESSORY - Matte Black
Strainer - QBSBL

ACCESSORY - Gloss White
Strainer - QBSGWH

Stocked Color Options

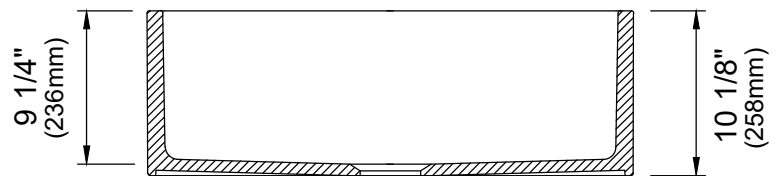
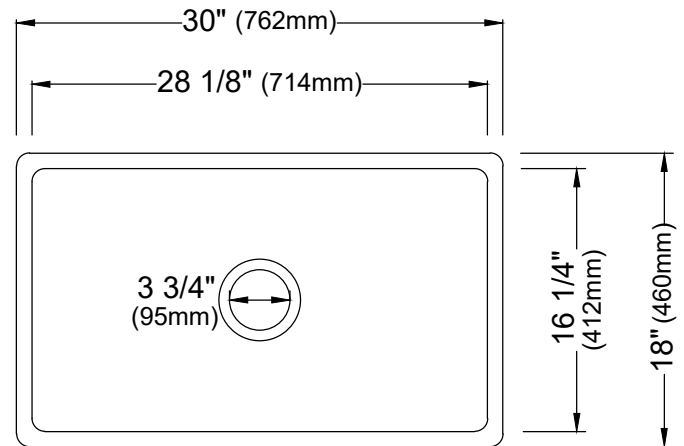
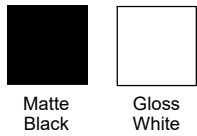

Flat Front

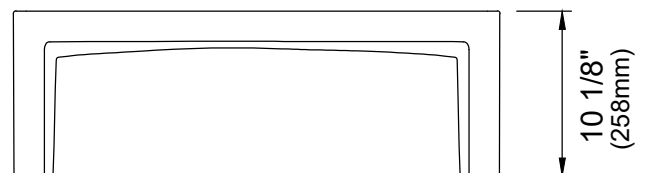

Panel Front

Listing and certifications:
cUPC

Limited lifetime warranty

We reserve the right to update product specifications without notice. Please visit karran.com for the most current specification sheets. All dimensions are accurate to 1/4". REV 02-2026