

SYEEDEE

ASSEMBLY INSTRUCTIONS

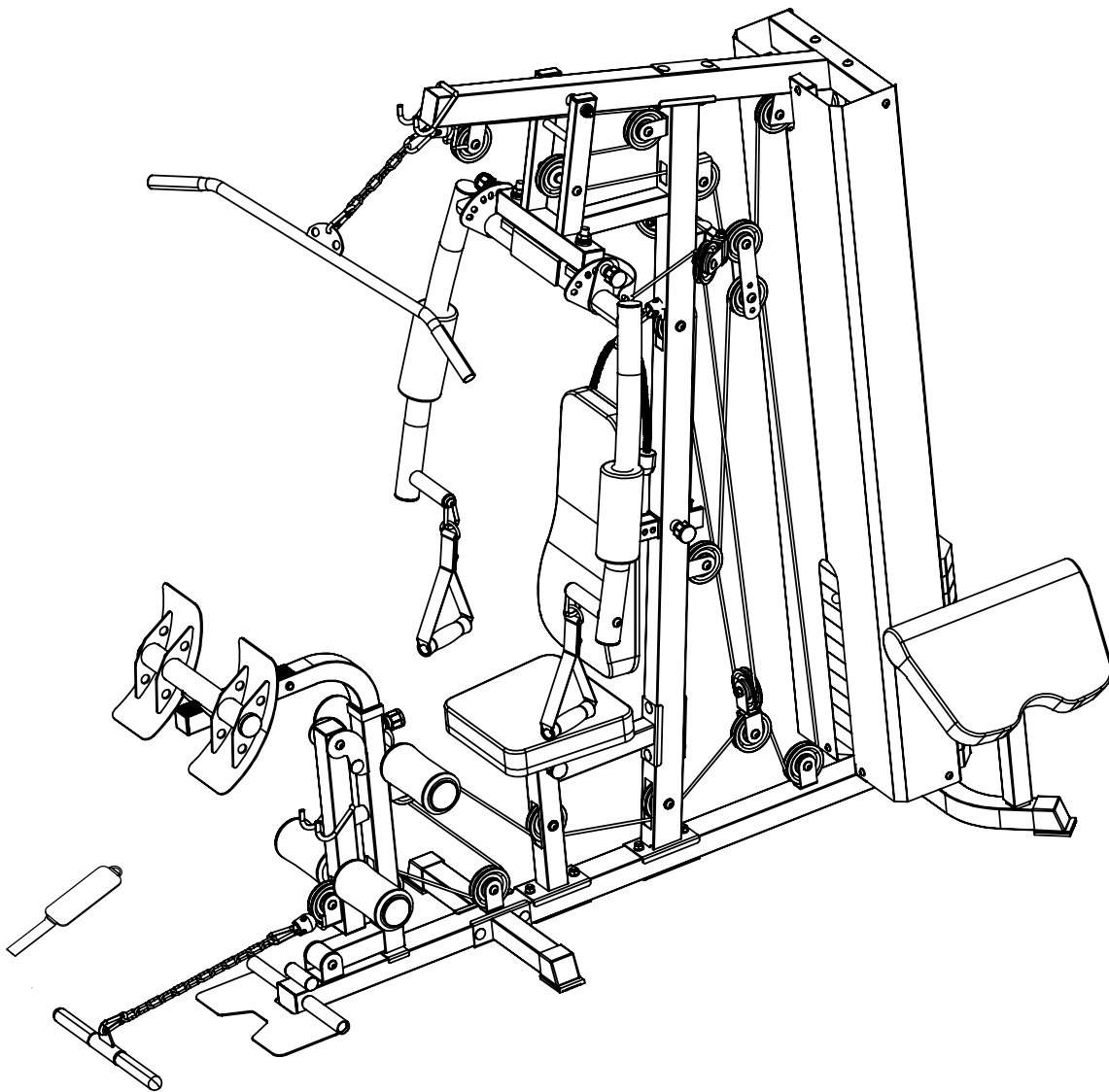

HGS

Read all precautions and instructions in this manual before using this

Assembly Caution	-----	4
Part List	-----	5
Hardware List	-----	6
Step 1	-----	7
Step 2	-----	8
Step 3	-----	9
Step 4	-----	10
Step 5	-----	11
Step 6	-----	12
Step 7	-----	13
Step 8	-----	14
Step 9	-----	15
Step 10	-----	16

Step 11	-----	17
Step 12	-----	18
Step 13	-----	19
Step 14	-----	20
Step 15	-----	21
After-Sale Information	-----	22

ASSEMBLY CAUTION

Please carefully read the following information before installation

Assembling requires at least two people

Do not tighten all screws before assembly is complete

Ensure that all accessories are complete. If not, please contact us via email



If you are missing any parts, or otherwise have any warranty issues, please contact us first.

Shortcut: A Lot of People Doing That Way

To enhance your installation process for both speed and convenience, consider removing all accessories from the box, carefully opening the packaging, and arranging everything neatly on the floor. This preparation can streamline your setup experience.

The following tools might help you improve your installation experience

Adjustable wrenches



Rubber hammers

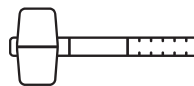

Socket set

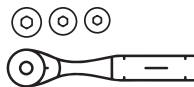

Electric Wrench

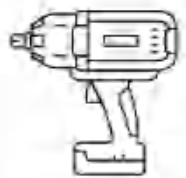

WARNING



Choking hazard. Small parts-Please exercise caution if small children or pets are present.











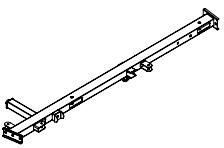
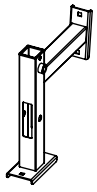
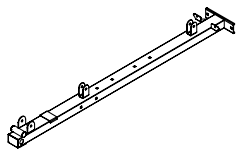
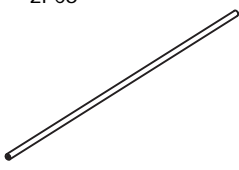
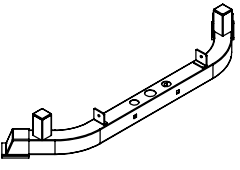
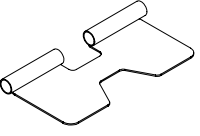
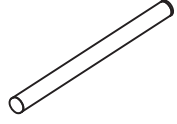
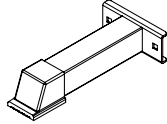
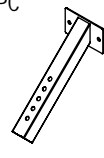
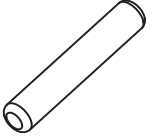
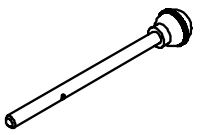

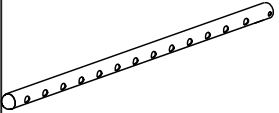

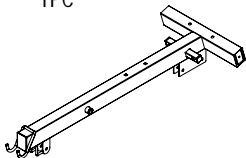
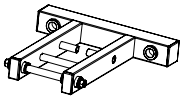
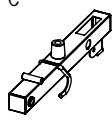
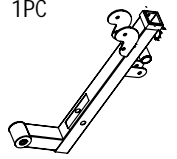
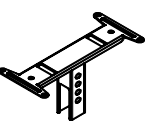
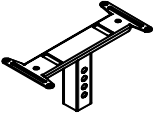
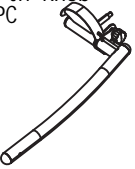
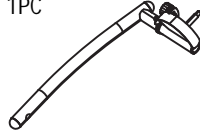
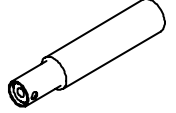
Sharp objects may be involved. Use precaution and protection.

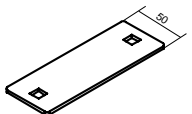
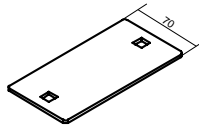
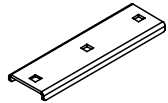
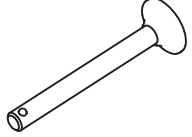

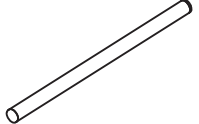
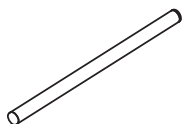

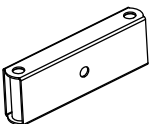
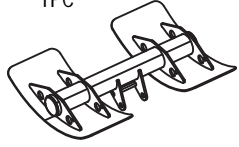

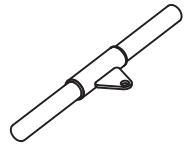



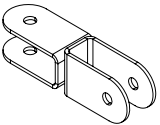
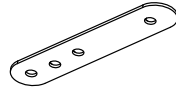
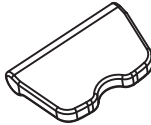

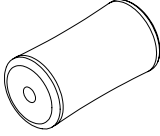
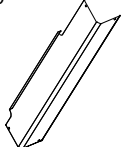
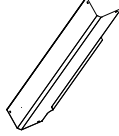
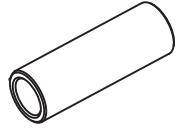
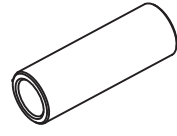

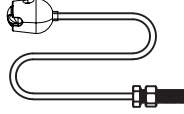
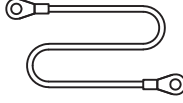
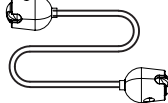
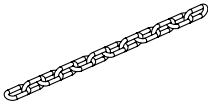
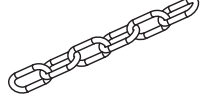
Heavy object. Use lifting aids and proper lifting techniques when moving

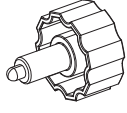

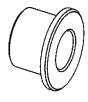
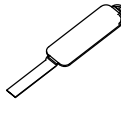
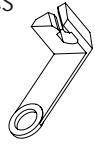







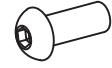
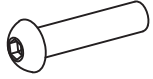
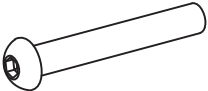
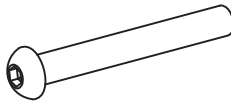
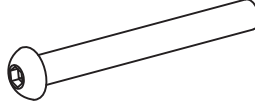
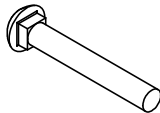
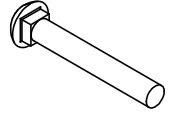

PARTS LIST

A1 Front Upright 1PC 	A2 Seated Pad Connecting 1PC 	A3 Front Base 1PC 	A4 Guide Rod 2PCS 	A5 Back Base 1PC 
A6 Foot Pedal 1PC 	A7 Footboard Connecting Rod 1PC 	A8 Stable Base 2PCS 	A9 Preacher Pad Connecting 1PC 	A10 Weight Stack Pin 1PC 
B1 Weight Stack Pin 1PC 	B2 Weight Washer 1PC 	B3 Top Weight Stack 1PC 	B4 Insert Lifting Rod 1PC 	B5 Weight Stack Washer 1PC 
B6 Weight Stack 12PCS 	B7 Top Frame 1PC 	B8 Jammer Arm Connecting With G5, G6, 20 1PC 	B9 Leg Extension Arm 1PC 	B10 Front Insert Tube With Bushing x2 1PC 
C1 Back Pad Connecting 1PC 	C2 Seat Pad Connecting 1PC 	C3 Right Jammer Arm With Knob 1PC 	C4 Left Jammer Arm With Knob 1PC 	C5 Jammer Arm Handle 2PCS 
C6 Foam Sleeve 2PCS 	C7 Connecting Plate 2PCS 	C8 Connecting Plate 2 2PCS 	C9 U Connecting Plate 1PC 	C10 Locking Pin 2PCS 
D1 Rubber Cushion Pad 2PCS 	D2 Foam Sleeve Roller(433mm) 1PC 	D3 Foam Sleeve Roller(400mm) 1PC 	D4 Foam Plug 4PCS 	D5 Pulley Stand-B 2PCS 
D6 Pulley Stand-A 1PC 	D7 Leg Press Pedal 1PC 	D8 Leg Press Pedal Connecting 1PC 	D9 Lat Pull Down Bar 1PC 	D10 Short Straight Bar 1PC 

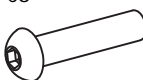

PARTS LIST

E1 Pulley Stand-C 1PC 	E2 Pulley Stand-D 2PCS 	E3 Preacher Pad 1PC 	E4 Back Pad 1PC 	E5 Seated Pad 1PC 	
E6 Foam Sleeve 4PCS 	E7 Right Shell 1PC 	E8 Left Shell 1PC 	E9 Roller A (60mm) 1PC 	E10 Roller B (63mm) 1PC 	
F1 Pulley 21PCS 	F2 Cable A (2980mm) 1PC 	F3 Cable B (2970mm) 1PC 	F4 Cable C (5065mm) 1PC 	F5 Chain (12) 1PC 	
F6 Chain (6) 1PC 	F7 Clip 7PCS 	F8 Knob 3PCS 	F9 Tricep Rope 1PC 	F10 Cable Handle 2PCS 	
G1 Pulley Spacer Sleeve 8PCS 	G2 Ankle Ring 1PC 	G3 Pulley Rope 8PCS 	G4 Pulley Sleeve 8PCS 	G5 Bushing (Ø16mm) 6PCS 	G6 Bushing (Ø29mm) 4PCS 

HARDWARE LIST

1 Bolt (M6 x 12) 3PCS 	2 Bolt (M8 x 16) 14PCS 	3 Bolt (M10 x 20) 7PCS 	4 Bolt (M10 x 25) 2PCS 	5 Bolt (M10 x 45) 12PCS 
6 Bolt (M10 x 70) 6PCS 	7 Bolt (M10 x 85) 2PCS 	8 Bolt (M10 x 175) 1PC 	9 Bolt (M10 x 70) 6PCS 	10 Bolt (M10 x 90) 6PCS 
12 Washer (M16) 2PCS 	13 Washer (M6) 3PCS 	14 Washer (M10) 71PCS 	15 Washer (M8) 14PCS 	16 Locknut (M10) 37PCS 
17 Locknut (M16) 2PCS 	18 Locknut (M6) 3PCS 	19 Bolt (M10 x 55) 4PCS 	20 Double-Ended Bolt 1PC 	

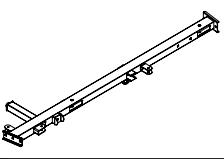
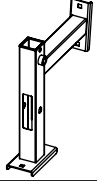
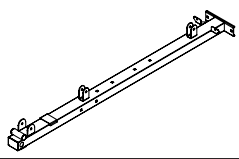
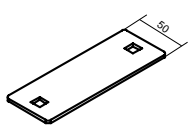
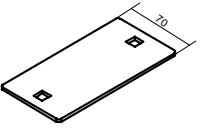
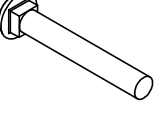
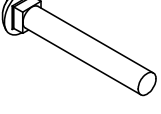
STEP 1:

A1 Front Upright 1PC 	A2 Seated Pad Connecting 1PC 	A3 Front Base 1PC 	C7 Connecting Plate 1PC 	C8 Connecting Plate B 2PCS 
9 Bol t(M10 x 70) 4PCS 	10 Bol t(M10 x 90) 2PCS 	14 Washer (M10) 6PCS 	16 Locknut (M10) 6PCS 	

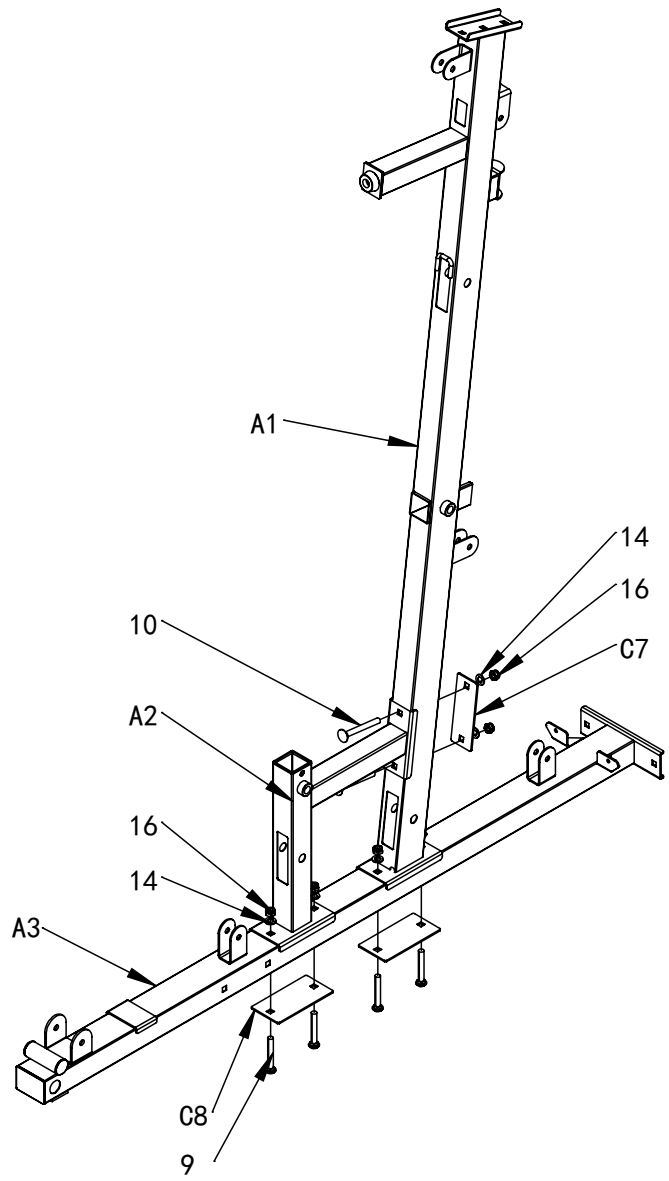

STEP 2:

A4 Guide Rod
2PCS

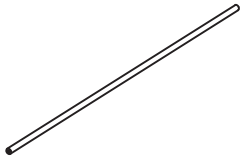

A5 Back Base
1PC

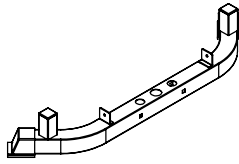





3 Bol t (M10 x 20)
2PCS

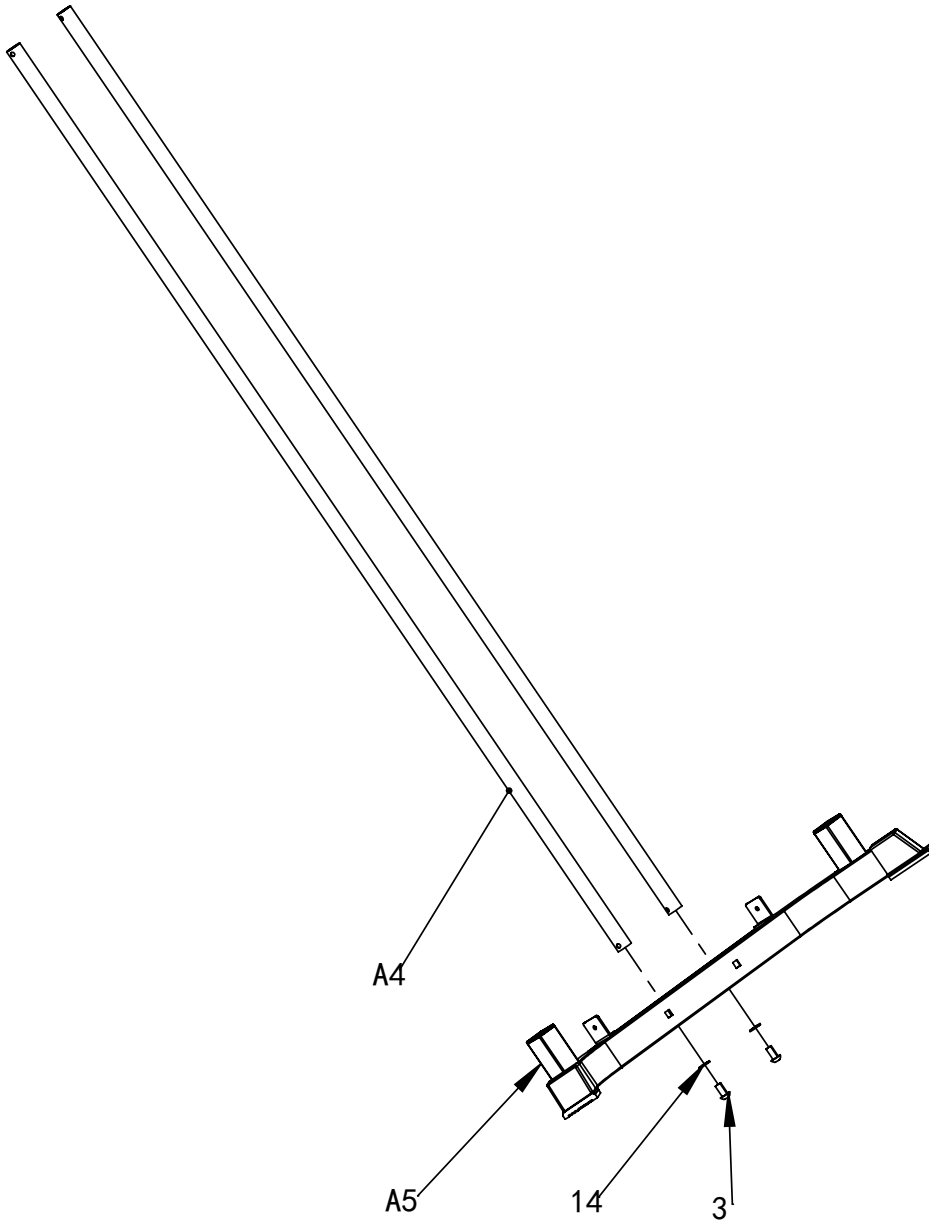

14 Washer (M10)
2PCS

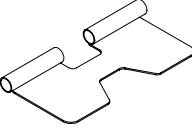
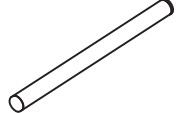
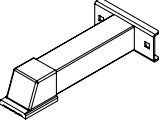
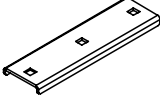

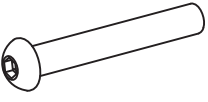
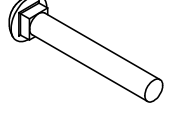
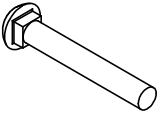
STEP 3:

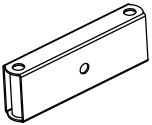
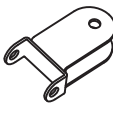
A6 Foot Pedal 1PC 	A7 Footboard Connecting Rod 1PC 	A8 Stable Base 2PCS 	C9 U Connecting Plate 1PC 	3 Bolt (M10 x 20) 1PC 
6 Bolt (M10 x 70) 2PCS 	9 Bolt (M10 x 70) 2PCS 	10 Bolt (M10 x 90) 2PCS 	14 Washer (M10) 9PCS 	16 Locknut (M10) 6PCS 
D6 Pulley Stand-A 1PC 	D5 Pulley Stand-B 2PCS 			

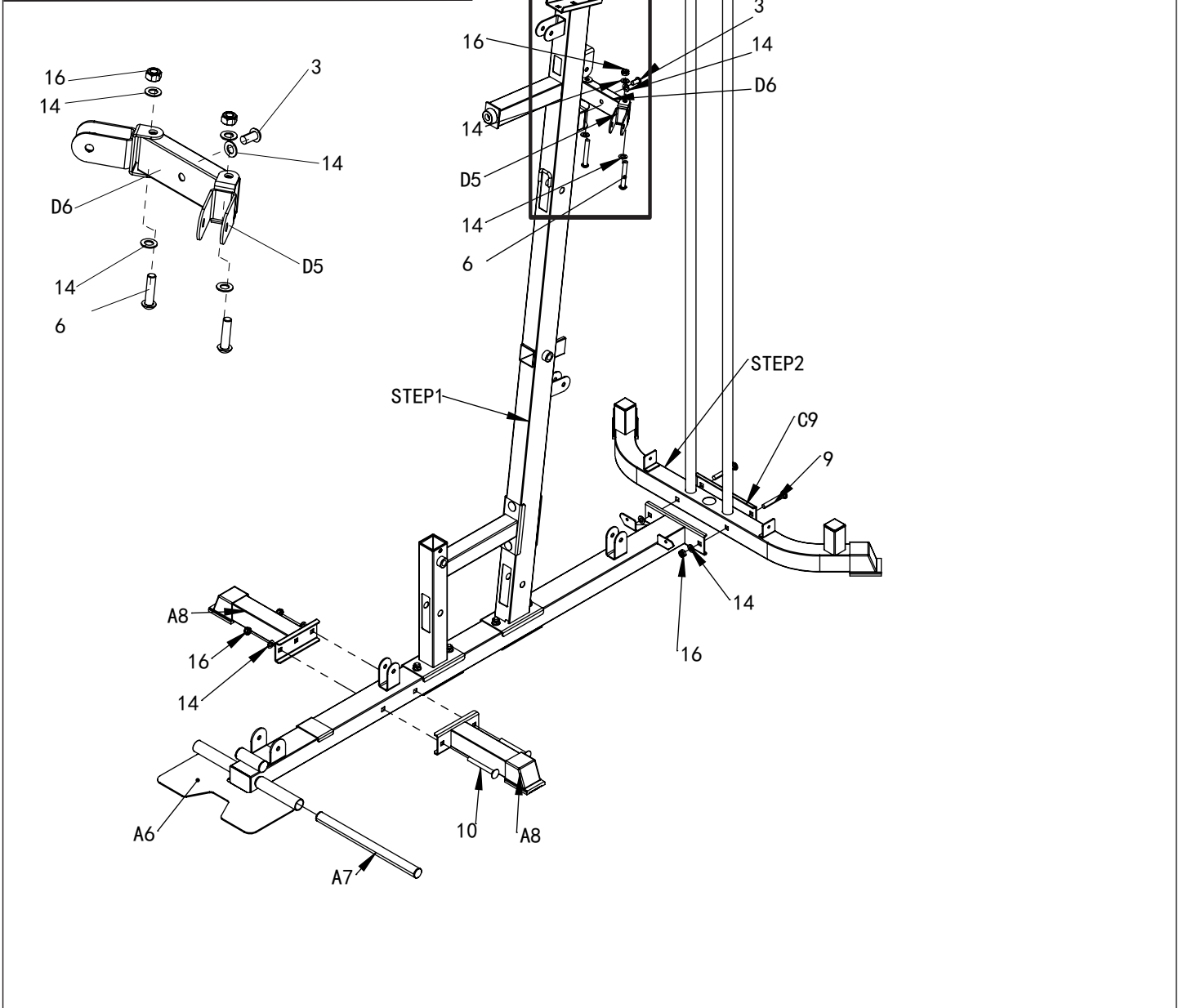

STEP 4:

A10 Weight Stack Pin
1PC



B1 Weight Stack Pin
1PC

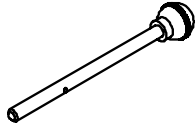

B3 Top Weight Stack
1PC

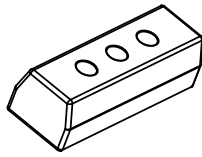

B4 Insert Lifting Rod
1PC

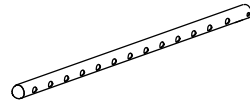

B5 Weight Stack Washer
1PC



B6 Weight Stack
12PCS

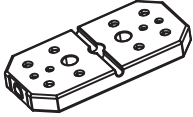

D1 Rubber Cushion Pad
2PCS

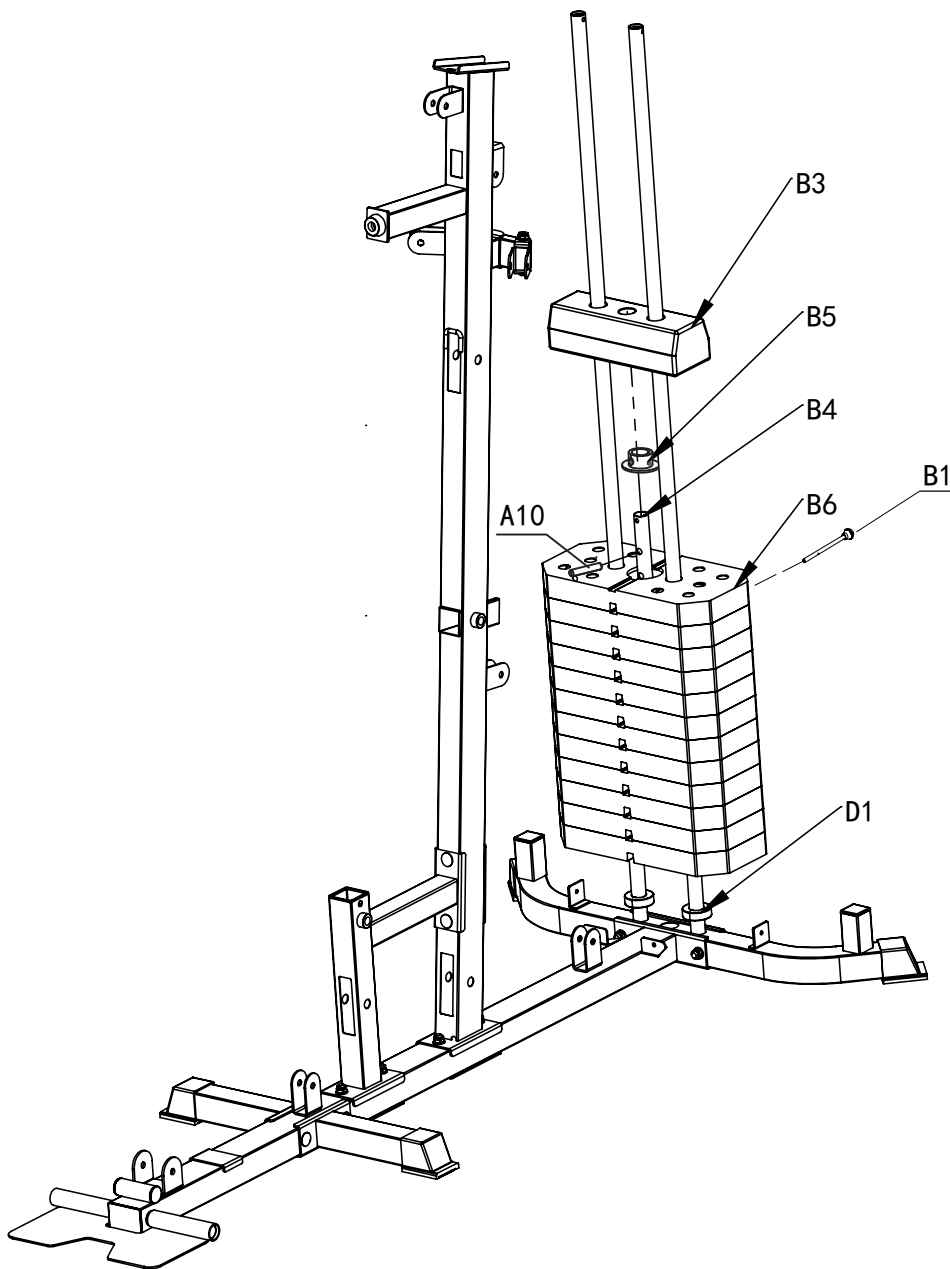
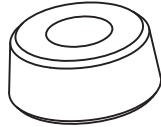

STEP 5:

B7 Top Frame
1PC

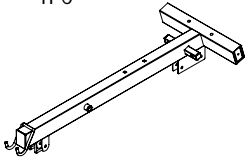

C7 Connecting Plate
1PC

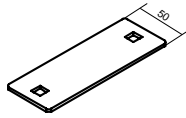

3 Bol t (M10 x 20)
2PCS



10 Bol t (M10 x 90)
2PCS

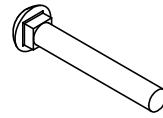

14 Washer (M10)
4PCS



16 Locknut (M10)
2PCS

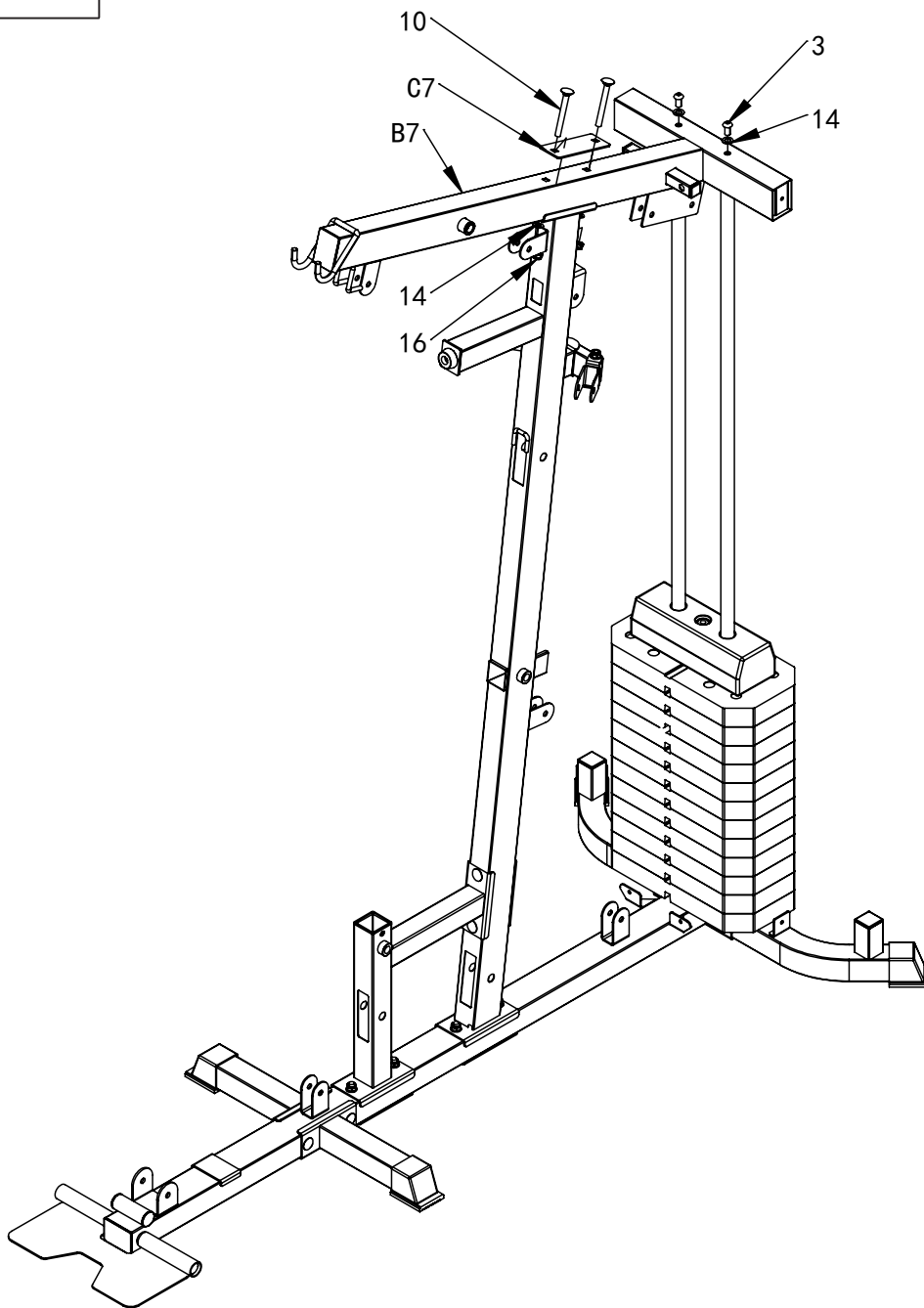

STEP 6.



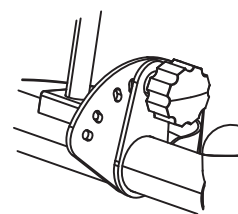
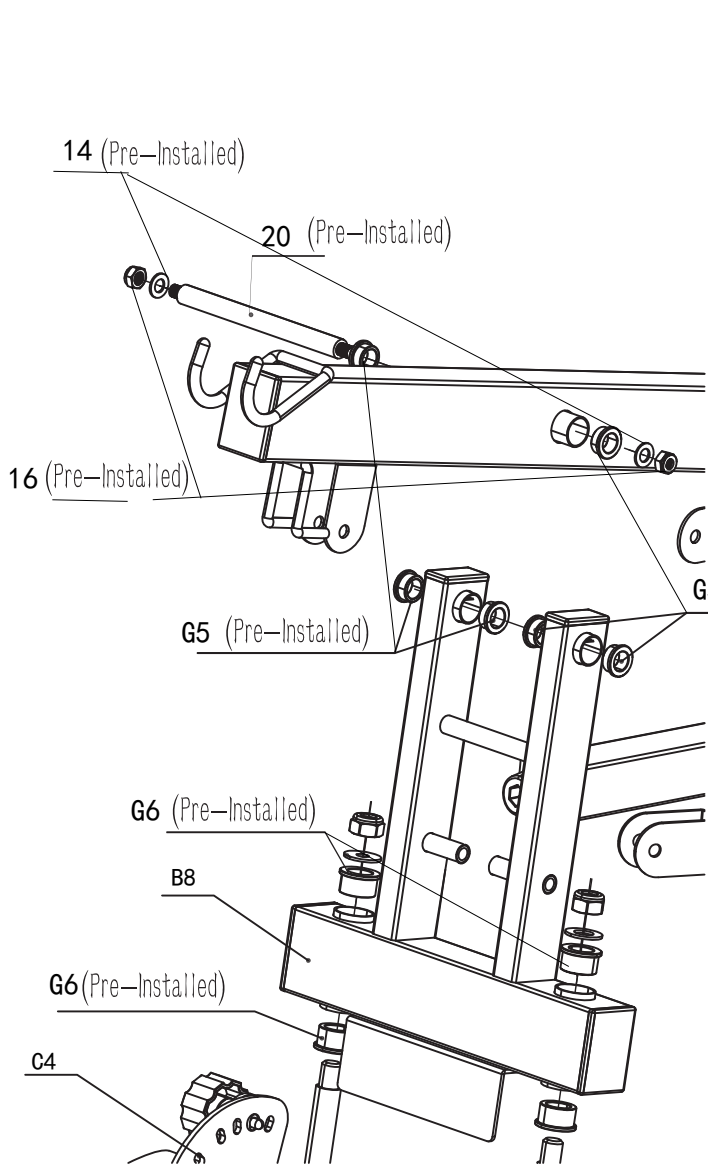

B8 Jammer Arm Connecting With G5, G6, 20 1PC	C3 Right Jammer Arm 1PC	C4 Left Jammer Arm 1PC	20 Double-Ended Bolt 1PC (Pre-Installed)	17 Locknut (M16) 2PCS
12 Washer (M16) 2PCS	G5 Bushing (Ø16mm) (Pre-Installed) 6PCS	G6 Bushing (Ø29mm) (Pre-Installed) 4PCS	14 Washer (M10) 9PCS	16 Locknut (M10) 6PCS

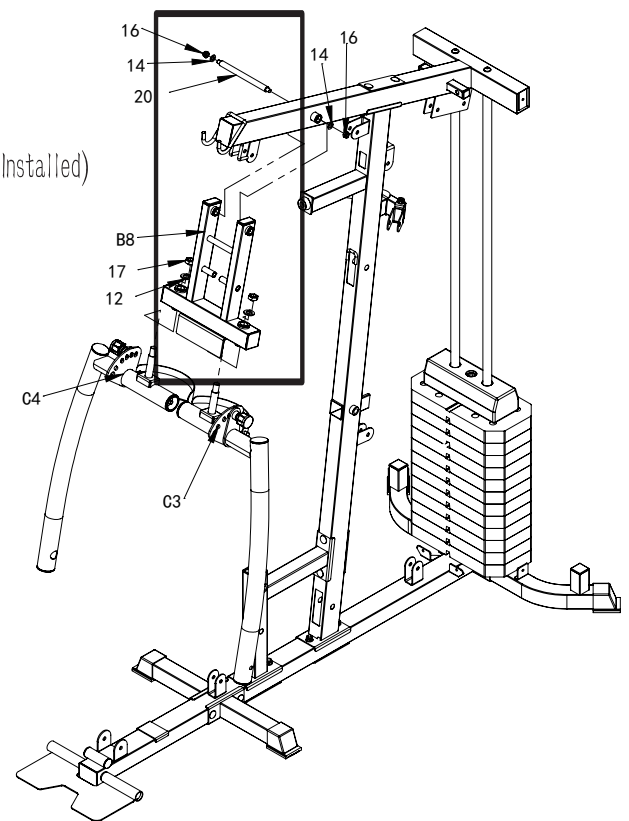

You can adjust the angle of the push arm here to use different movements.

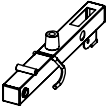
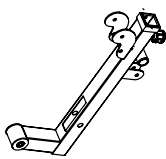
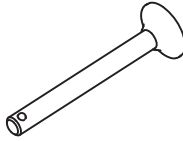
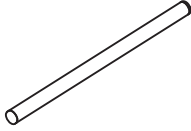
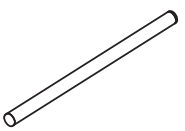

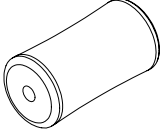
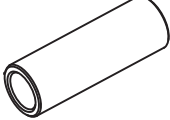
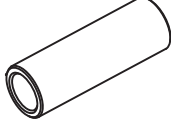
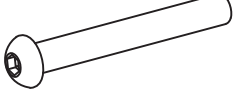



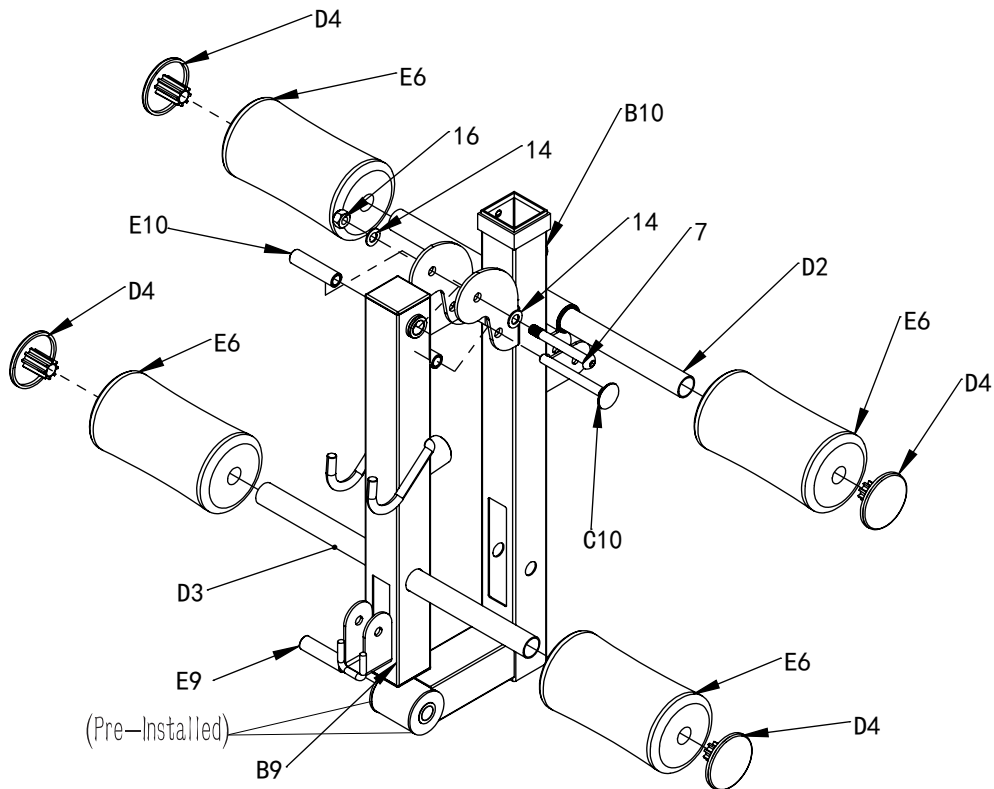

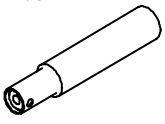

STEP 7:

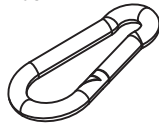
B9 Leg Extension Arm 1PC 	B10 Front Insert Tube 1PC 	C10 Locking Pin 1PC 	D2 Foam Sleeve Roller(433mm) 1PC 	D3 Foam Sleeve Roller(400mm) 1PC 
D4 Foam Plug 4PCS 	E6 Foam Sleeve 4PCS 	E9 Roller A(60mm) 1PC 	E10 Roller B (63mm) 1PC 	7 Bolt(M10 x 85) 1PC 
14 Washer(M10) 2PCS 	16 Locknut(M10) 1PC 			

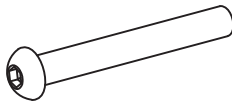





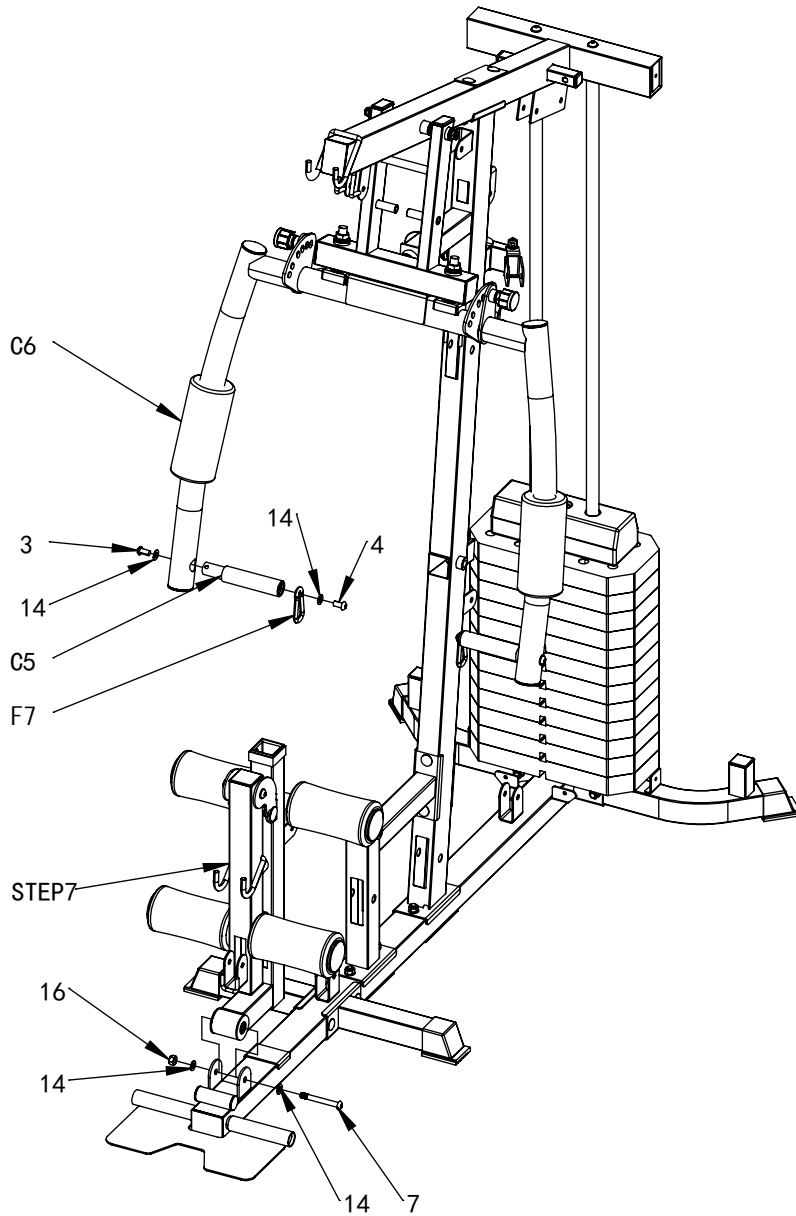

STEP 8:

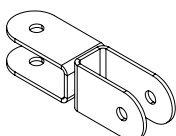
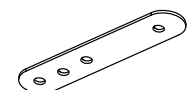
C5 Jammer Arm Handle 2PCS 	C6 Foam Sleeve 2PCS 	F7 CLi p 2PCS 	3 Bol t(M10 x 20) 2PCS 	7 Bol t(M10 x 85) 1PC 
14 Washer (M10) 6PCS 	16 Locknut (M10) 1PC 	4 Bol t(M10 x 25) 2PCS 		

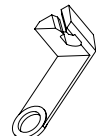

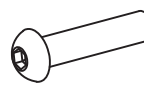
STEP 9:

E1 Pulley Stand-C 1PC 	E2 Pulley Stand-D 2PCS 	F1 Pulley 4PCS 	G3 Pulley Rope 8PCS 	G4 Pulley Sleeve 8PCS 
19 Bolt (M10 x 55) 4PCS 	14 Washer (M10) 8PCS 	16 Locknut (M10) 4PCS 		

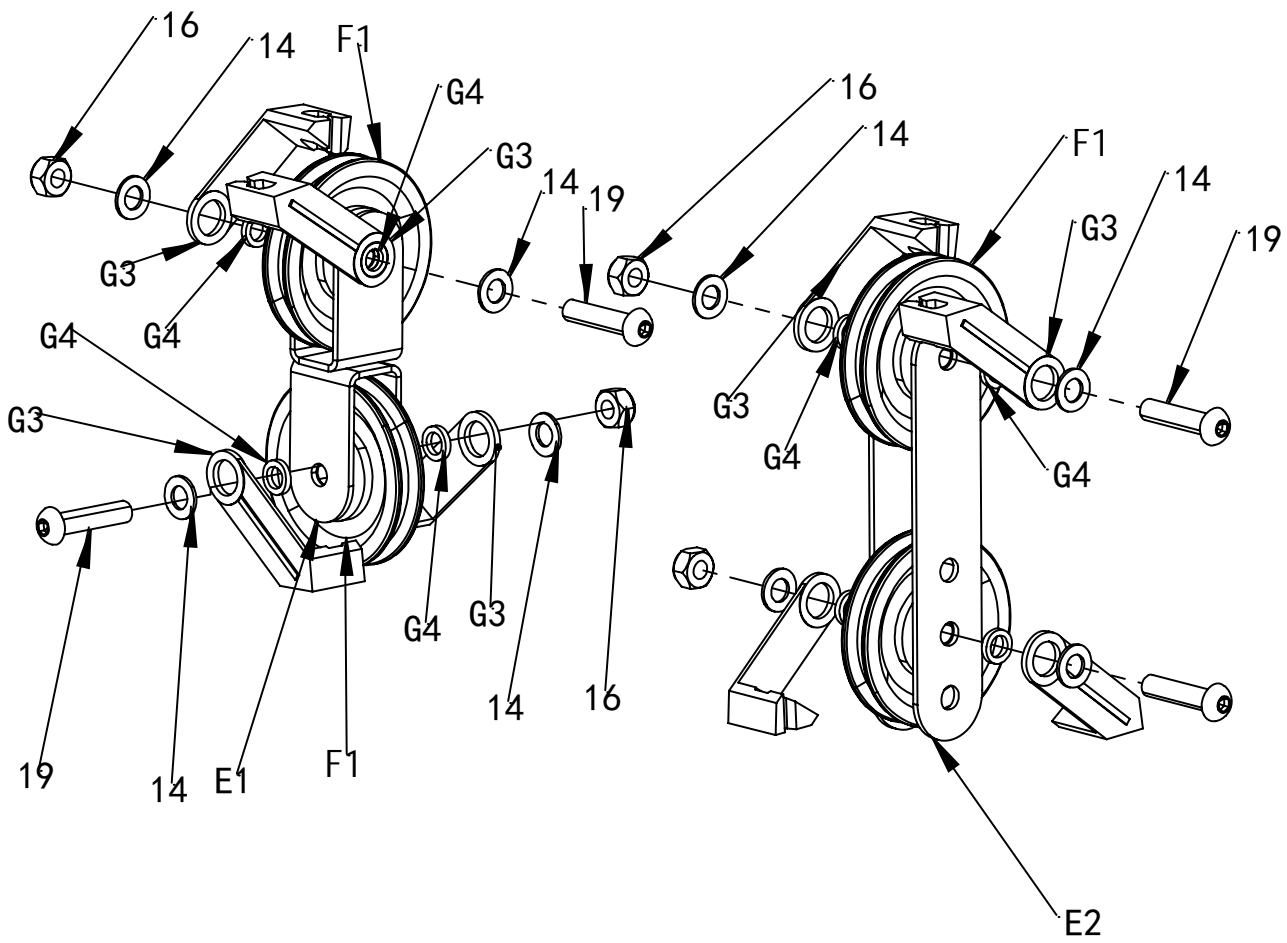

STEP10:

F2 Cable A (2980mm)
1PC

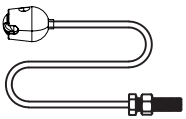

F1 Pulley
6PCS



STEP9

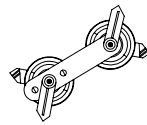

B2 Weight Washer
1PC



F7 Clip
1PC



8 Bolt (M10 x 175)
1PC

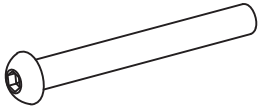

14 Washer (M10)
12PCS



16 Locknut (M10)
6PCS



5 Bolt (M10 x45)
5PCS

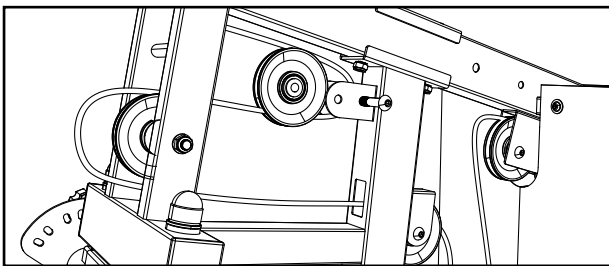
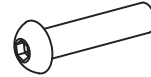

Please install the rope and pulley at the same time

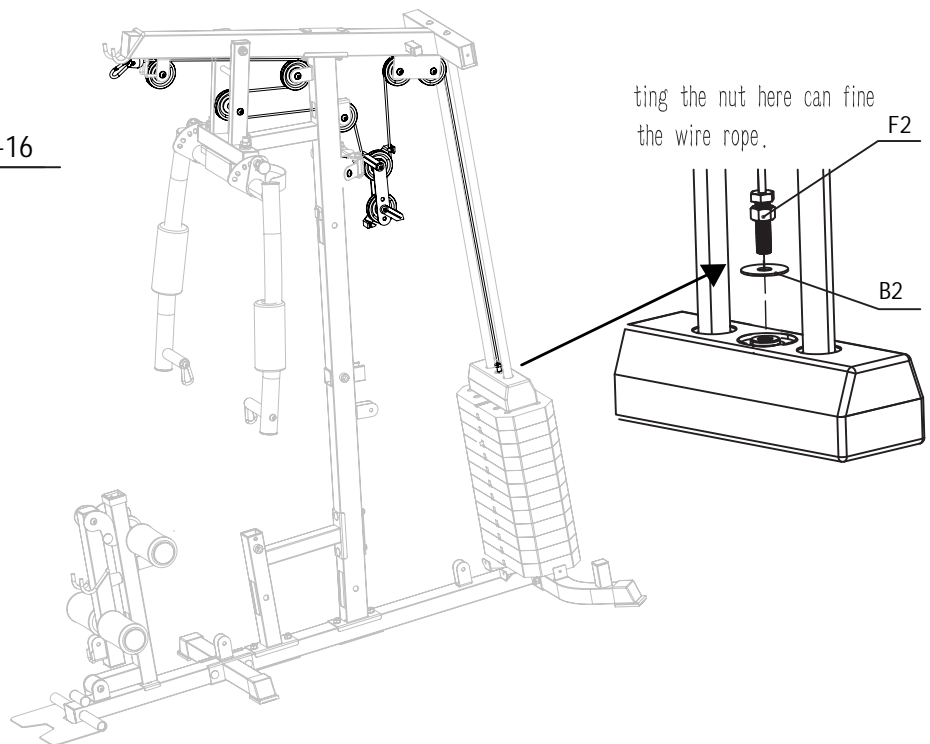
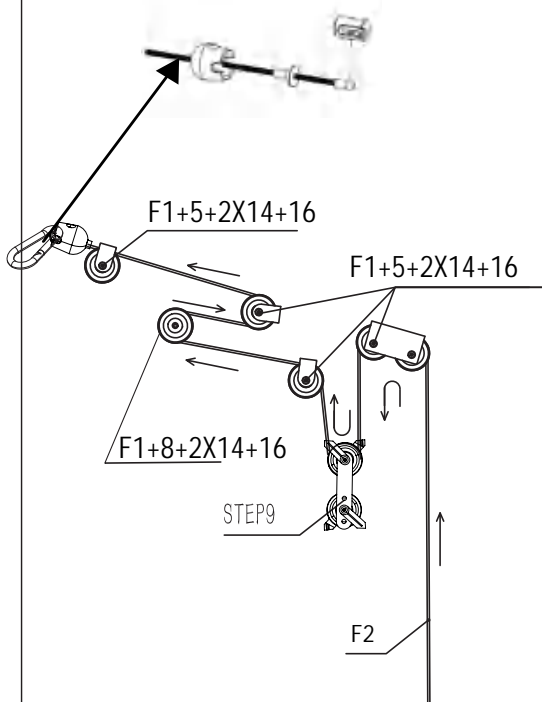
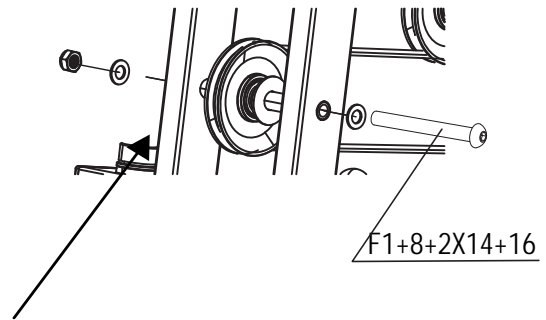

STEP 11:

F3 Cable B (2970mm)
1PC

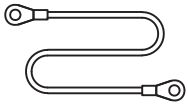

F1 Pulley
2PCS



STEP9



5 Bolt (M10 x45)
2PCS

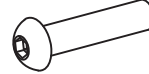

14 Washer (M10)
4PCS



16 Locknut (M10)
2PCS

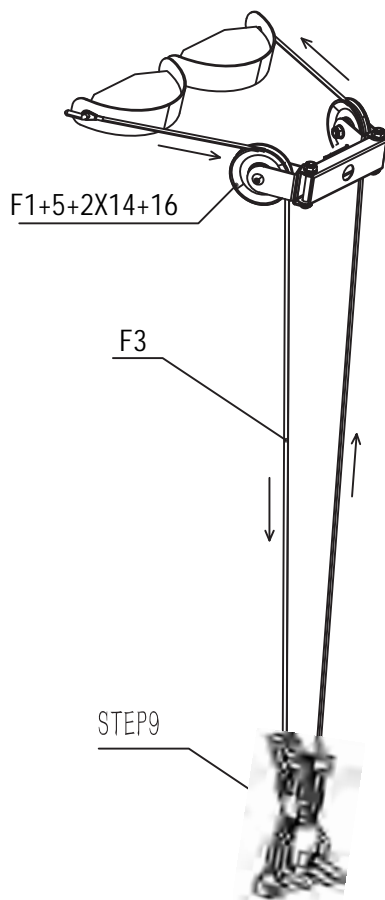

Please install the rope and pulley at the same time

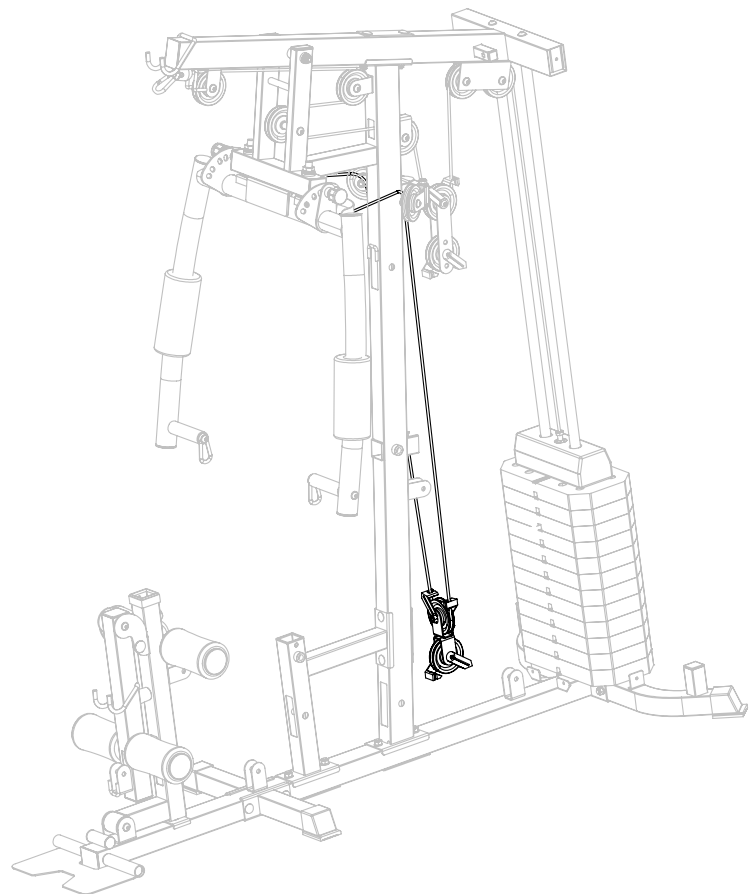

STEP 12:

F4 Cable C (5065mm)
1PC

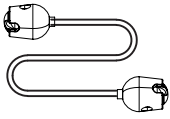

F1 Pulley
9PCS



5 Bolt (M10 x45)
5PCS

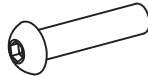

14 Washer (M10)
18PCS



16 Locknut (M10)
9PCS



G1 Pulley Spacer
Sleeve
8PCS

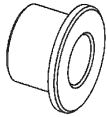

6 Bolt (M10 x70)
4PCS

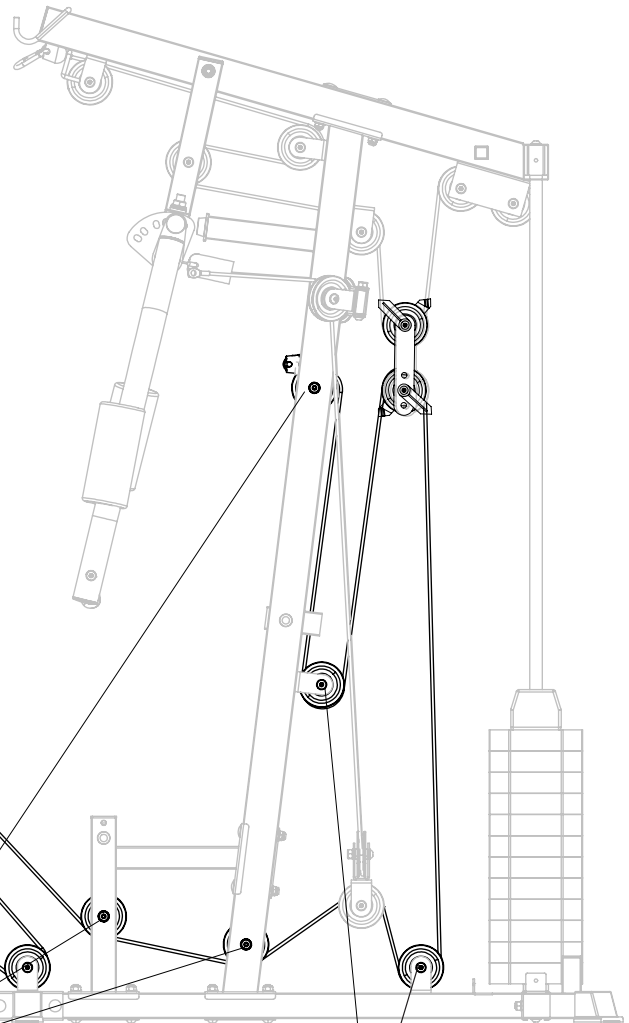
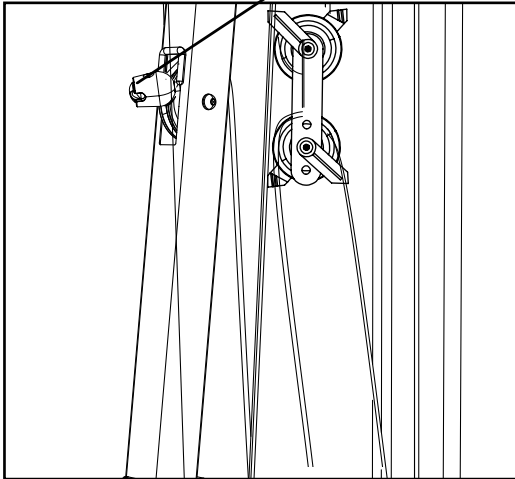
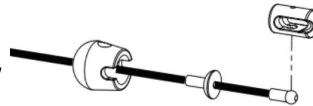
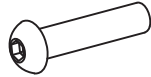

Please install the rope and pulley at the same time

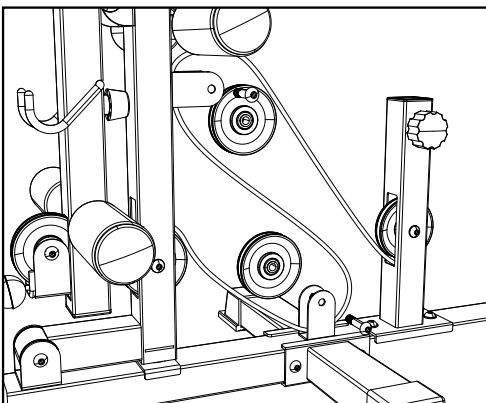







F1+5+2X14+16

F1+2XG1+6+2X14+16

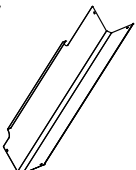
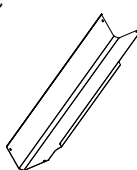
F1+5+2X14+16



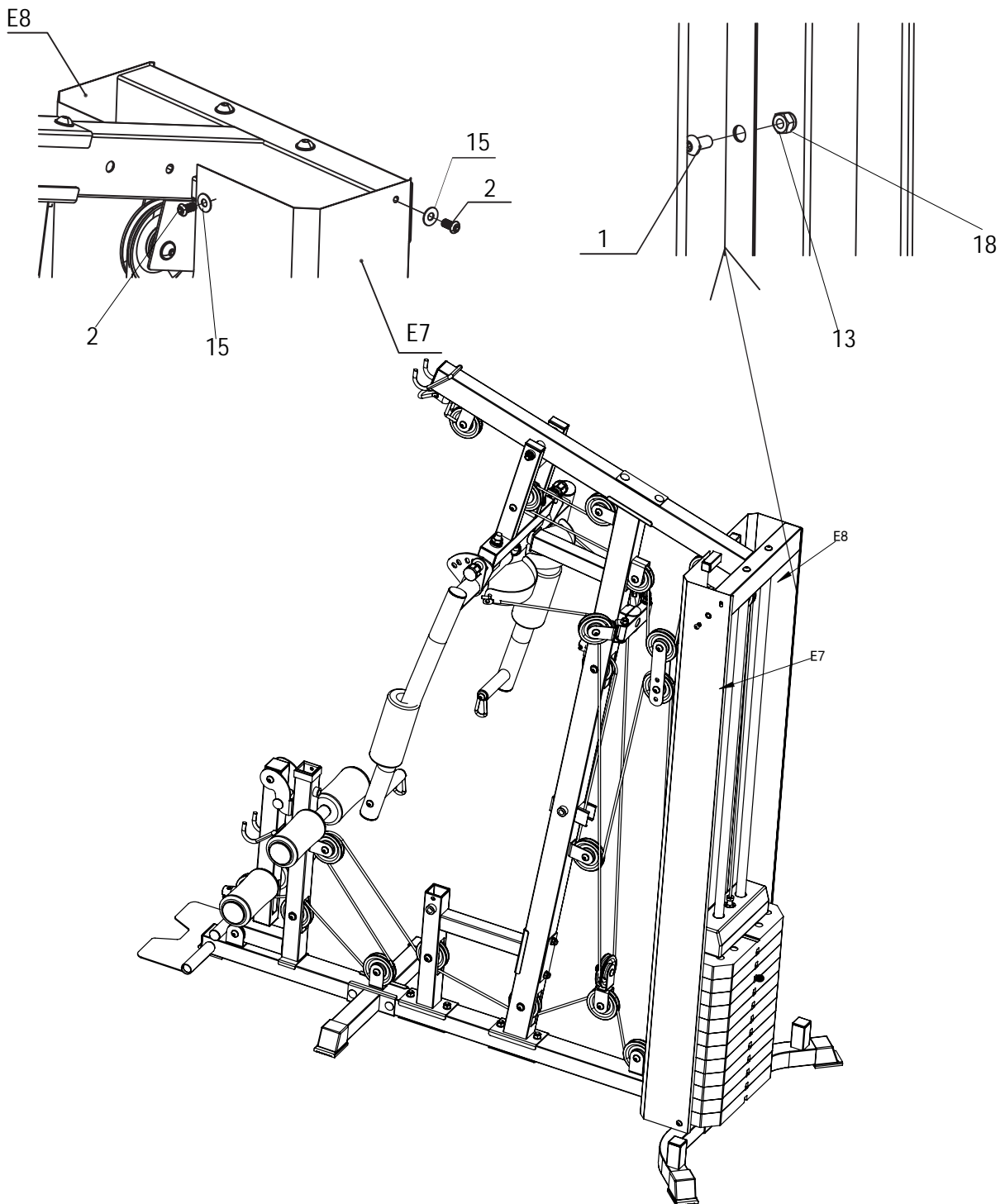

Adjust these pulley brackets and two wheels
Sub-spacing allows for simultaneous adjustment of steel wires
Roughly adjust the length of the rope and increase the spacing
Reducing the spacing means tightening the steel wire rope

STEP 13:

E7 Right Shell 1PC 	E8 Left Shell 1PC 	2 Bol t (M8 x16) 8PCS 	15 Washer (M8) 8PCS 	13 Washer (M6) 3PCS 
1 Bol t (M6 x 12) 3PCS 	18 Locknut (M6) 3PCS 			



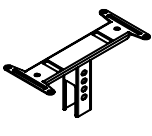
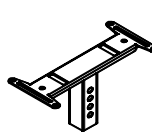

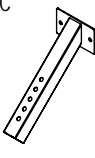

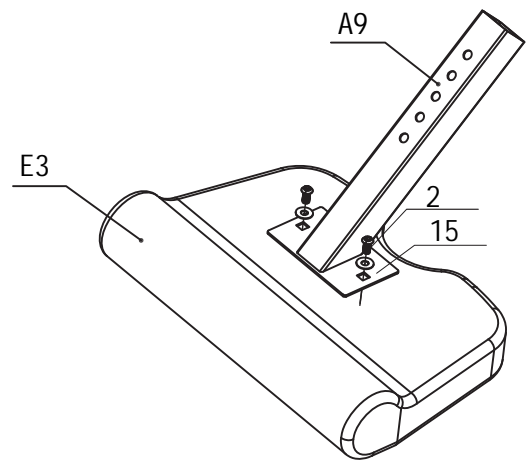
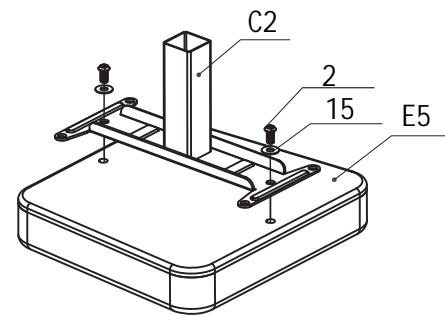
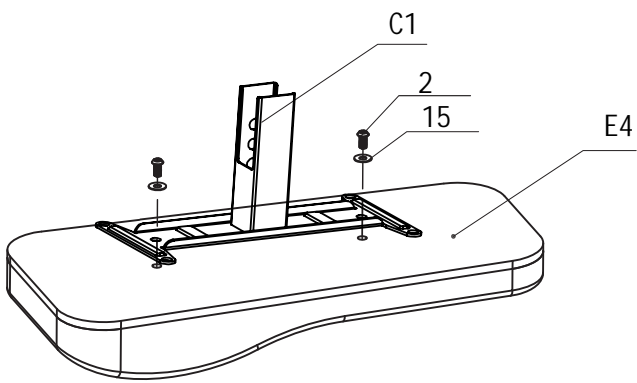

STEP 14:

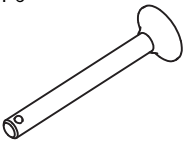
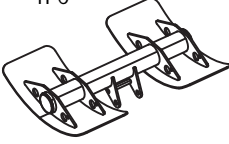
<p>E3 Preacher Pad 1PC</p> 	<p>E4 Back Pad 1PC</p> 	<p>E5 Seated Pad 1PC</p> 	<p>C1 Back Pad Connecting 1PC</p> 	<p>C2 Seat Pad Connecting 1PC</p> 
<p>2 Bol t (M8 x16) 6PCS</p> 	<p>15 Washer (M8) 6PCS</p> 	<p>A9 Preacher Pad Connecting 1PC</p> 		

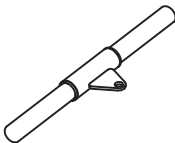
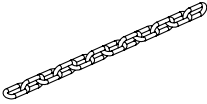
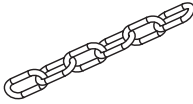

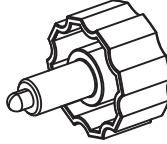
STEP 15:

C10 Locking Pin 1PC 	D7 Leg Press Pedal 1PC 	D8 Leg Press Pedal Connecting 1PC 	D9 Lat Pull Down Bar 1PC 	D10 Short Straight Bar 1PC 
F5 Chain (12) 1PC 	F6 Chain (6) 1PC 	F7 Clip 4PCS 	F8 Knob 3PCS 	F9 Tri cep Rope 1PC 
F10 Cable Handle 2PCS 	G2 Ankle Ring 1PC 