



Gasoline Engine

Operator's Manual

MODEL NUMBER
LC152F-1

SERIAL NUMBER

PURCHASE DATE

Both model number and serial number may be found on the main label. You should record both of them in a safe place for future use.

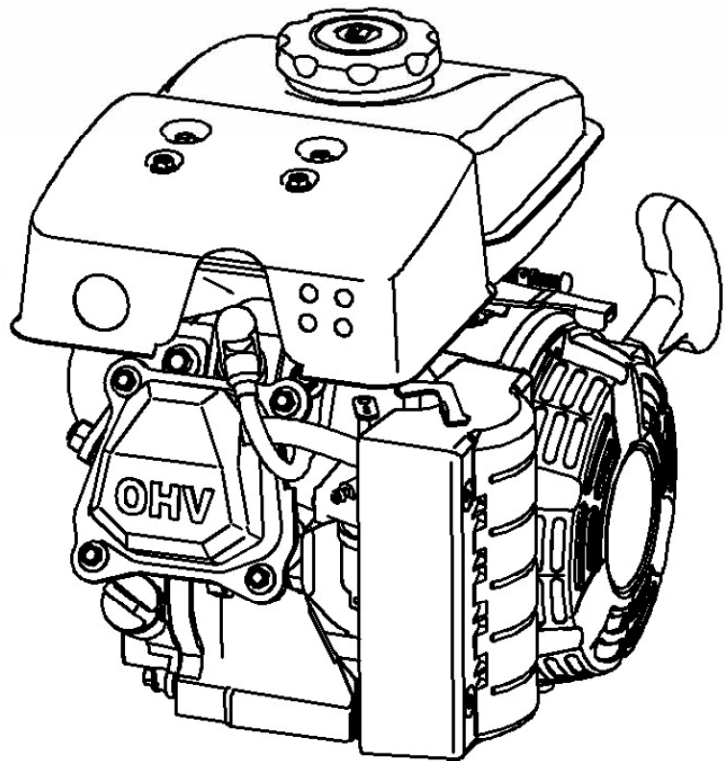

FOR YOUR SAFETY

READ AND UNDERSTAND THE ENTIRE MANUAL BEFORE OPERATING MACHINE

Your new YARDMAX® engine offers quality construction that is easy and safe to operate. With proper use and care, it is designed to give you many years of dependable service.

Prepare to experience the durability to take on any job with the ease, portability, and convenience of your new engine!

Discover the YARDMAX Advantage

At YARDMAX, we understand that land ownership definitely has its privileges, but it also comes with a great deal of responsibility. When duty calls and you need to respond, will you have what it takes to tame the great outdoors?

When looking for outdoor power equipment (OPE) to get the job done right, at the right price, YARDMAX delivers the perfect combination of performance and practicality. YARDMAX has a solution that’s right for you.

MAX Performance, MAX Value, MAX Support – that’s YARDMAX

- ✓ Backed by decades of proven manufacturing expertise
- ✓ Enhanced design features come standard
- ✓ Engineered for the best user experience
- ✓ Quality metal parts are used instead of plastic
- ✓ A robust warranty supports all products
- ✓ Budget-friendly prices make it practical



Up for the job? YARDMAX is.

TABLE OF CONTENTS

Introduction	1
Specifications	3
Safety	4
Know Your Engine	5
Controls	6
Check before Operation	7

Operation	8
Maintenance	9
Storage	13
Troubleshooting	14
Technical & Consumer Information	15
Wiring Diagram	16

DISCLAIMER

Keep this owner's manual handy, so you can refer to it at any time.

This owner's manual is considered a permanent part of the engine and should remain with the engine if resold.

The information and specifications included in this publication were in effect at the time of approval for printing.

READ THIS OWNER'S MANUAL CAREFULLY. Pay special attention to these symbols and any instructions that follow:



Warning!

Indicates serious injury or death will result if instructions are not followed.



Danger!

Indicates a strong possibility that serious injury or death could result if instructions are not followed.



Caution!

Indicates a possibility that minor injury or an result if instructions are not followed.



Notice:

Indicates that equipment or property damage can result if instructions are not followed.



Carefully read through this entire operator's manual before using your new engine. Pay attention to all cautions and warnings.

ENVIRONMENTAL



Recycle unwanted materials instead of disposing of them as waste. All tools, hoses, and packaging should be taken to the local recycling center and disposed of in an environmentally safe way.

ENGINE SERIAL NUMBER

Record the engine serial number on the front cover of this manual. You will need this serial number when ordering parts, and when making technical or warranty inquires.

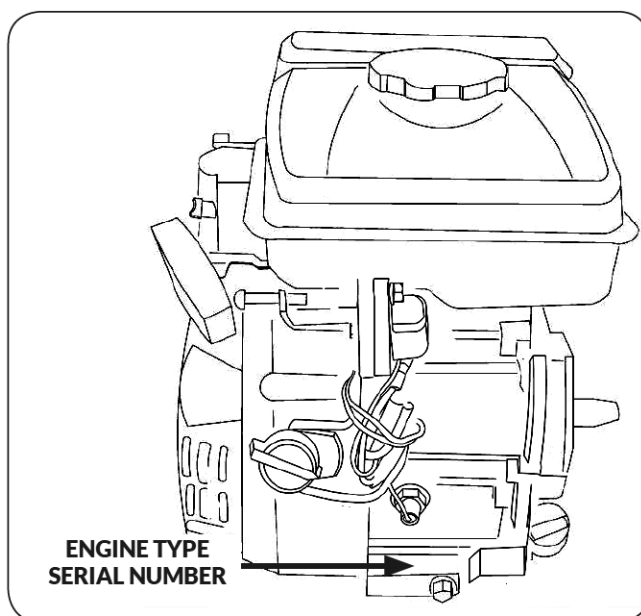

DISCLAIMER

YARDMAX reserves the right to discontinue, change, and improve its products at any time without notice or obligation to the purchaser. The descriptions and specifications contained in this manual were in effect at printing. Equipment described within this manual may be optional. Some illustrations may not be applicable to your unit.

SUPPORT

I have questions about your YARDMAX equipment? Call us at 844-927-3629 or 844-YARDMAX, email us at support@yardmax.com, or contact us via your favorite social media site.

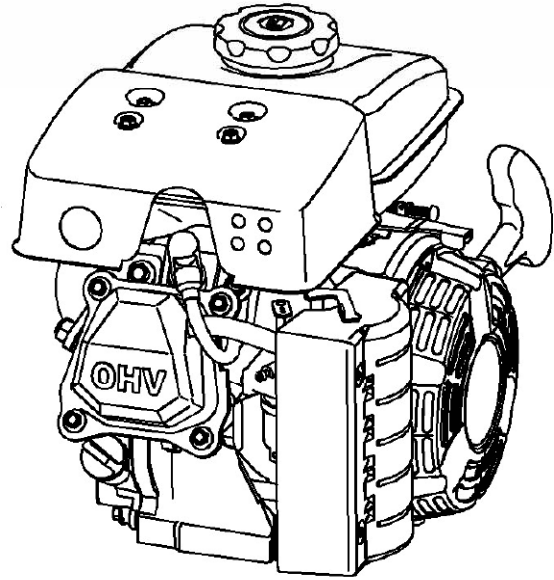

SPECIFICATIONS

Model	152F-1
Type	Single cylinder 4-Stroke Forced air cooling
Rated power (kW/3600rpm)*	1.5Kw/3600rpm
Max torque N•m/rpm	4N.m/3400rpm
Fuel consumption ratio (g/kW•h)	≤450
Idle speed (rpm)	2000±150
Speed fluctuating ratio	≤10%
Noise ≤ dB(A)	90
Bore×Stroke (mm)	52X37
Displacement (cc)	79
Compression ratio	8.5:1

Lubricating mode	Splash	
Starting mode	Recoil start	
Rotation	Anti-clockwise (from P.T.O.Side)	
Valve clearance (mm)	Intake valve 0.10-0.15 Exhaust valve 0.15-0.20	
Spark plug gap (mm)	0.7~0.8	
Ignition mode	Transistorized magneto ignition	
Air cleaner	Single element	
Dimension (inch)	Length	12.2
	Width	10.2
	Height	12
Net weight (lbs)	23.1	

* The power rating of the engine indicated in this document is the net power output tested on a production engine for the engine model and measured in accordance with SAE J1349 at 3,600 rpm (Net Power) and at 3,800 rpm (Max. Net Torque). Mass production engines may vary from this value.

* Actual power output for the engine installed in the final machine will vary depending on numerous factors, including the operating speed of the engine in application, environmental conditions, maintenance, and other variables.

SAFETY

IMPORTANT SAFETY INFORMATION

Most accidents with engines can be prevented if you follow all instructions in this manual and on the engine. Some of the most common hazards are discussed below, along with the best way to protect yourself and others.

OWNER RESPONSIBILITIES

- YARDMAX engines are designed to give safe and dependable service if operated according to instructions. Read and understand this owner's manual before operating the engine. Failure to do so could result in personal injury or equipment damage.
- Know how to stop the engine quickly, and understand the operation of all controls. Never permit anyone to operate the engine without proper instructions.
- Do not allow children to operate the engine. Keep children and pets far away from the area of operation.

OPERATOR SAFETY

Safety Measures



Warning!

Wash hands after using the machine, refueling, and changing fluids. Certain components in this product and its accessories contain chemicals known to cause cancer, birth defects, or other reproductive harm according to the State of California.



Warning!

Always run your engine outdoors. Exhaust from the engine contains fumes known to cause cancer, birth defects, or other reproductive harm according to the State of California.



Warning!

YARDMAX engines are not engineered or intended to be used to power any other device than what it was originally specified in. Including but not limited to competitive racing events, recreational, sport or all-terrain vehicles (ATV's), go-karts, fun-karts, golf-carts, etc.

START/STOP SAFETY

Starting The Engine



Warning!

Kick back or rapid retraction of the recoil cord will pull the operators hand and arm towards the engine quicker than you can let go.

Avoiding Kick Back

- Lightly pull the recoil handle so that the cord is taught prior to pulling harder to start.
- Grip the starter handle so you can quickly release it if needed. If gripped too tightly injury could result.
- When the rope is taut with resistance pull quickly and smoothly to avoid kick back.

FUEL SAFETY



Warning!

Fuel and its vapors are extremely flammable and explosive. Fire or explosion can cause severe burns or death. Keep fuel away from sparks, open flames, pilot lights, heat sources, or any other ignition sources. If fuel spills, wait for it to completely evaporate before starting the engine.

HOT EXHAUST

- The muffler will become very hot during operation and will remain hot for a while after stopping the engine. Be careful not to touch the muffler while it is hot. Let the engine cool before storing it indoors.
- To prevent fire hazards and to provide adequate ventilation for stationary equipment applications, keep the engine at least 3 feet (1 meter) away from both building walls and from other equipment during operation. Do not place flammable objects close to the engine.

CARBON MONOXIDE HAZARD

Exhaust gas contains poisonous carbon monoxide. Avoid inhalation of exhaust gas. Never run the engine in a closed garage or confined area.

OTHER EQUIPMENT

Review the instructions provided with the equipment powered by this engine for any additional safety precautions that should be observed in conjunction with engine startup, shutdown, operation, or protective apparel that may be needed to operate the equipment.

KNOW YOUR ENGINE

FEATURES AND CONTROLS

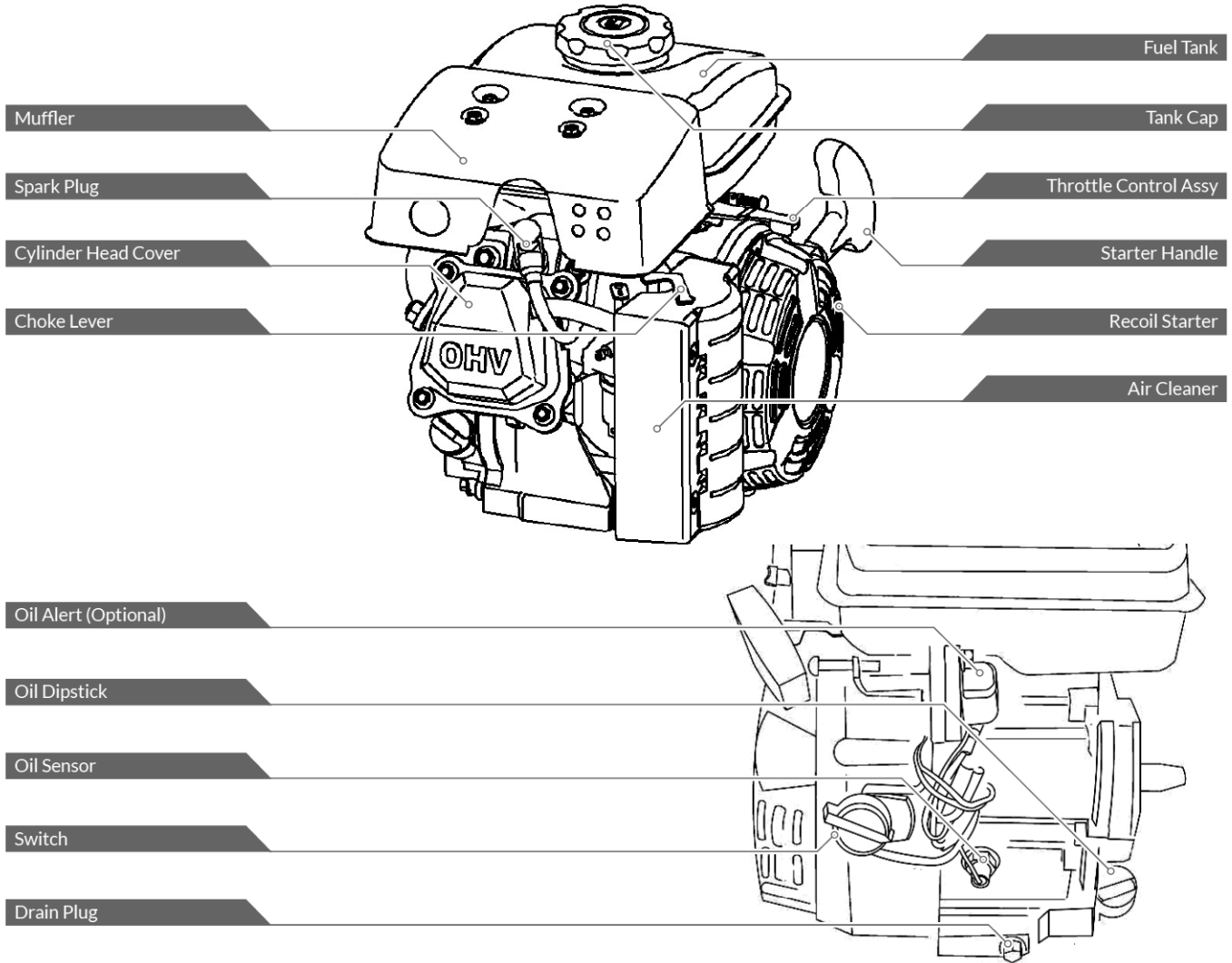

CONTROLS

ENGINE SWITCH

The engine switch enables and disables the ignition system.

The engine switch must be in the ON position for the engine to run.

Turning the engine switch to the OFF position stops the engine.

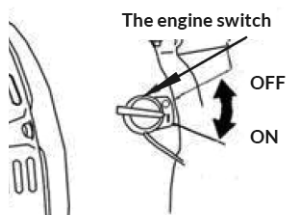

CHOKE LEVER

The choke lever opens and closes the choke valve in the carburetor.

Set lever "CLOSE" for starting a cold engine.

After starting, set the choke lever to "OPEN" position.

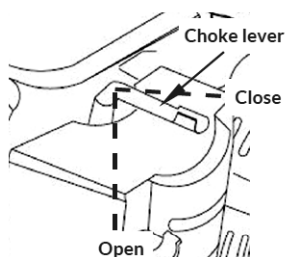

RECOIL STARTER GRIP

Pulling the starter grip operates the recoil starter to crank the engine.



Caution!

Don't let the lever suddenly rebound, lightly put the lever back.

GOVERNOR LEVER

Adjust the throttle lever position to get required speed.

For proper engine speed, refer to indication provided by equipment.

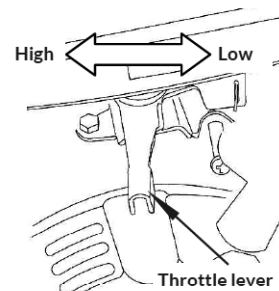

OIL PROTECTION SYSTEM (OPTIONAL)

The oil protection system will stop engine operation if oil levels fall below a safe operating level. This will prevent engine damage from occurring. To regain engine operation, fill the oil crankcase up to a safe operating level indicated on the oil dipstick.



Caution!

If the engine will not start or automatically stops during operation, first check the engine oil and fuel levels.

Starter Grip

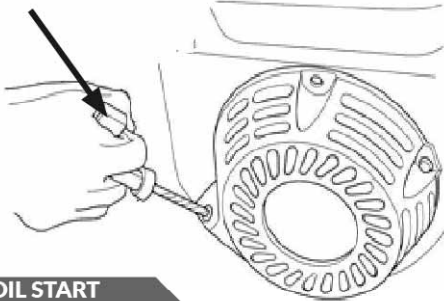

Figure 1

CHECK BEFORE OPERATION

CHECK BEFORE OPERATION

IS YOUR ENGINE READY TO GO?



Notice:

Your engine is shipped from YARDMAX without oil. Add oil per the instructions before starting.

For your safety, and to maximize the service life of your equipment, it is very important to take a few moments before you operate the engine to check its condition. Be sure to take care of any problem you find, or have your servicing dealer correct it, before you operate the engine.



Warning!

Improperly maintaining this engine, or failing to correct a problem before operation, could cause a malfunction in which you could be seriously injured.



Warning!

Always perform a preoperation inspection before each operation, and correct any problem.

Before beginning your preoperation checks, be sure the engine is level and the engine key has been removed.

1. Check the General Condition of the Engine

- Look around and underneath the engine for signs of oil or gasoline leaks.
- Remove any excessive dirt or debris, especially around the muffler and recoil starter.
- Look for signs of damage.
- Check that all shields and covers are in place, and all nuts, bolts, and screws are tightened.

2. Check Oil (See **Figure 2**)



Caution!

Always check the engine oil on a level surface.

- 1) Remove the oil dipstick and clean off with a towel.
- 2) Re-insert the oil dipstick and check the oil level without screwing it down.
- 3) If the oil is too low, add enough oil to reach the high area of the upper limit zone.
- 4) Reinstall and tighten oil dipstick back on the engine.

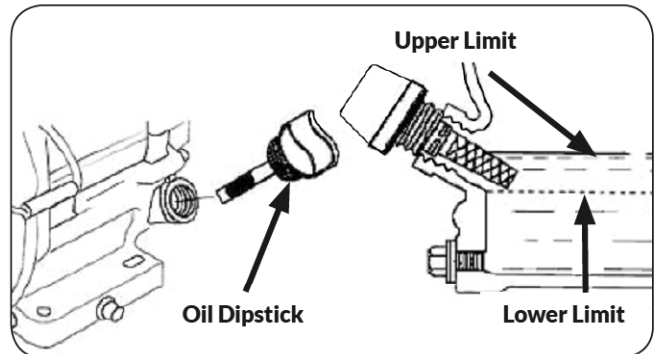

Figure 2



Notice:

Running the engine with a low oil level can cause engine damage, so always check the engine oil level before startup.

3. Check before Operation

- Check that the spark plug, muffler, fuel cap, and air cleaner (if equipped) are clean and secured in place.
- If the spark plug is unplugged or removed do not crank the engine.

CHECK FUEL (See **Figure 3**)

Turn engine off, open the fuel cap and check the fuel level. If the fuel level is too low, add fuel until full. When the unit has been filled completely, replace the fuel cap and tighten the fuel cap clockwise.

Refuel in a well-ventilated area before starting the engine. If the engine has been running, allow it to cool. Refuel carefully to avoid spilling fuel. Don't add the fuel over the shoulder of the Fuel Tank (maximum fuel level).

Never refuel the engine inside a building where gasoline fumes may reach flames or sparks. Keep gasoline away from appliance pilot lights, barbecues, electric appliances, power tools, etc.

Spilled fuel is not only a fire hazard, it causes environmental damage. Wipe up spills immediately.

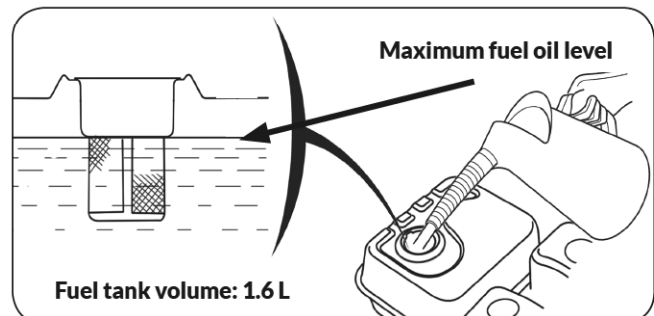

Figure 3

Only use unleaded gasoline with an octane rating over 90. This will help eliminate carbon deposits and extended the service life of the engine. Do not use gasoline mixed with oil or contaminated with dirt or water.

CHECK THE EQUIPMENT POWERED BY THIS ENGINE

Review the instructions provided with the equipment powered by this engine for any precautions and procedures that should be followed before engine startup.

CHECK AIR CLEANER (See **Figure 4**)

Remove the air cleaner housing and check the element, if the element is dirty, remove and clean. If the element is damaged, replace entire element.

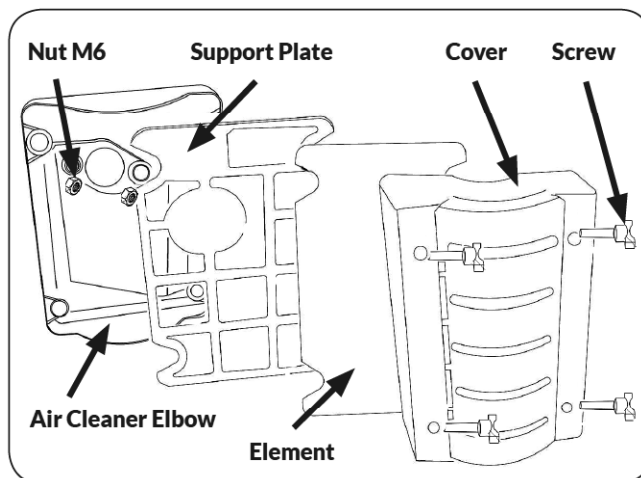

Figure 4

OPERATION

STARTING ENGINE

1. To start a cold engine, move the choke lever to the CLOSE position.

To start a warm engine, turn the choke lever to the OPEN position.

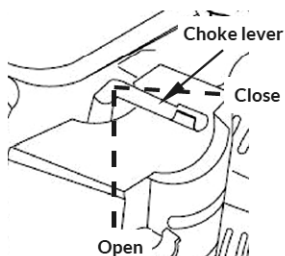

2. Move the throttle lever away from the LOW position, about 1/3 of the way toward the HIGH position.

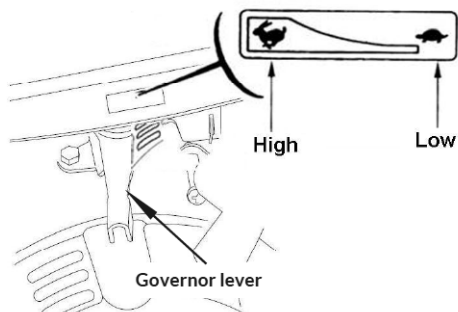

3. Turn the engine switch to the ON position.

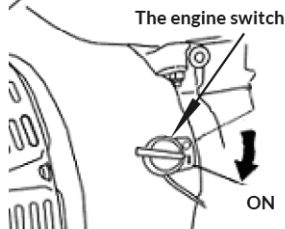

4. Pull the starter grip lightly until you feel resistance, then pull briskly. (See **Figure 5**)

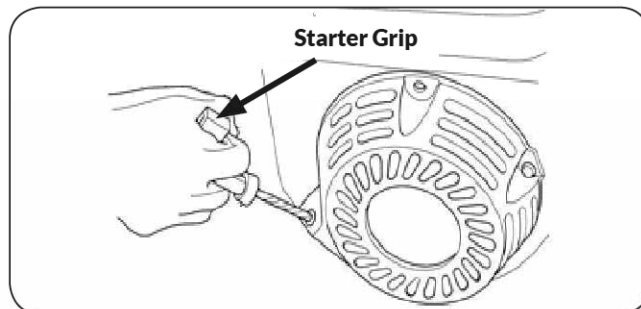
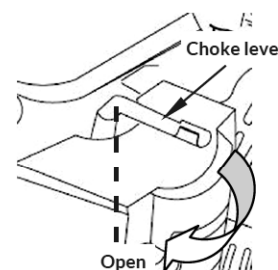

Figure 5

Caution!
 Don't let starting lever suddenly rebound, and lightly put the lever back.

5. If the choke lever has been moved to the CLOSE position to start the engine, gradually move it to the OPEN position as the engine warms up.



STOPPING THE ENGINE

To stop the engine in an emergency, simply turn the engine switch to the OFF position. Under normal conditions, use the following procedure.

1. Move the throttle lever to the LOW position

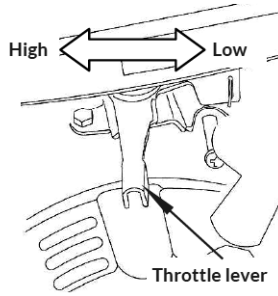

2. Turn the engine switch to the OFF position.

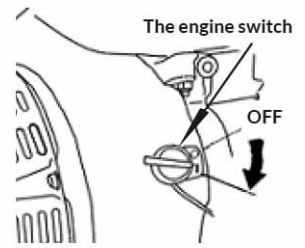

MAINTENANCE

MAINTENANCE SCHEDULE

REGULAR SERVICE PERIOD		Each use	First month or 20 Hrs.	Every 3 months or 50 Hrs.	Every 6 months or 100 Hrs.	Every year or 150 Hrs.
Engine oil	Check level	○				
	Change		○		○	
Air cleaner	Check	○				
	Clean		○(1)			
	Replace					○(2)
Sediment Cup	Clean				○	
Spark plug	Clean				○	Replace
Valve clearance	Check-Adjust					○(2)
Cover comp head	Clean	After every 300 Hrs. (2)				
Fuel tank and fuel filter	Clean	Every 2 years (Replace if necessary) (2)				
Fuel line	Check	Every 2 years (Replace if necessary) (2)				

(1) Service more frequently when used in dusty areas.

(2) These items should be serviced by your servicing dealer unless you have the proper tools and are mechanically proficient.

THE IMPORTANCE OF MAINTENANCE

We recommend you take your YARDMAX engine to a YARDMAX authorized service center to have all maintenance and service of the engine and its parts.



Warning!

Improperly maintaining this engine, or failure to correct a problem before operation, can cause a malfunction in which you can be seriously hurt or killed. Always follow the inspection and maintenance recommendations and schedules in this owner's manual.

To help you properly care for your engine, the following pages include a maintenance schedule, routine inspection procedures, and simple maintenance procedures using basic hand tools. Other service tasks that are more difficult, or require special tools, are best handled by professionals and are normally performed by a technician or other qualified mechanic.

The maintenance schedule applies to normal operating conditions. If you operate your engine under unusual conditions, such as sustained high-load or high-temperature operation, or use in unusually wet or dusty conditions, consult your servicing dealer for recommendations applicable to your individual needs and use.

SAFETY PRECAUTIONS



Warning!

The fuel tank must be emptied, if mounted on the engine, prior to performing maintenance. Tipping of the engine may cause the fuel to leak out causing a fire or explosion.



Warning!

Always unplug the spark plug before performing service. Spark can result in fire or electric shock.

Unintentional start up can create entanglement, laceration, or amputation.

- Before performing maintenance or service on your YARDMAX engine take the following steps to ensure a safe work environment

- Make sure all drive controls are disengaged.
- Move the stop switch to off or remove the ignition key if equipped.
- Unplug the spark plug wire.
- If the engine is installed on the machine block the wheels to prevent movement or tipping.
- To ensure safe operation after maintenance is performed follow these guidelines:
 - Use only the correct tools.
 - Do not tamper with the governor spring, links, or other parts to increase speed.
 - Only use YARDMAX approved replacement parts.
 - Do not strike the flywheel with a hammer or other hard object.
- When testing for spark:
 - Use an approved spark plug tester.
 - Never check for spark with the plug removed.
- Make sure the engine is off before you begin any maintenance or repairs. This will eliminate several potential hazards:
 - **Carbon monoxide poisoning from engine exhaust.**
Be sure there is adequate ventilation whenever you operate the engine.
 - **Burns from hot parts.**
Let the engine and exhaust system cool before touching.
 - **Injury from moving parts.**
Do not run the engine unless instructed to do so.
- Read the instructions before you begin, and make sure you have the tools and skills required.
- To reduce the possibility of fire or explosion, be careful when working around gasoline. Use only a nonflammable solvent, not gasoline, to clean parts. Keep cigarettes, sparks and flames away from all fuel-related parts.

Remember that your servicing dealer knows your engine best and is fully equipped to maintain and repair it.

To ensure the best quality and reliability, use only new, genuine parts or their equivalents for repair and replacement.

ENGINE OIL CHANGE

Drain the used oil while the engine is warm. Warm oil drains quickly and completely.

1. Place a suitable container below the engine to catch the used oil, and then remove the filler cap and the drain plug.
2. Allow the used oil to drain completely, and then reinstall the drain plug, and tighten it securely. Please dispose of used motor oil in a manner that is environmentally friendly. We suggest you take used oil in a sealed container to your local recycling center or service station for reclamation. Do not throw it in the trash; pour it on the ground; or down a drain.
3. With the engine in a level position, fill to the outer edge of the oil filler hole with the recommended oil.

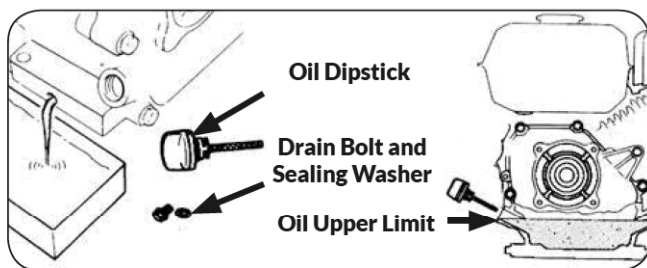

Figure 6

Engine oil capacities: 0.37 Quarts

Running the engine with a low oil level can cause engine damage.

If the engine is equipped the Oil Alert system. The Oil Alert system (applicable engine types) will automatically stop the engine before the oil level falls below the safe limit.

However, to avoid the inconvenience of an unexpected shutdown, fill to the upper limit, and check the oil level regularly.

4. Screw in the filler cap/dipstick securely.

ENGINE OIL RECOMMENDATIONS

Using the proper type and weight of oil in the engine is extremely important, as is daily checking of oil level oil, or using dirty oil, will cause premature engine wear and failure.

Oil Type - When the ambient temperature is under -25°C , SAE 0W-30/40 is recommended for general use; when the ambient temperature is above -25°C but under 4.4°C , SAE 5W-30 or 0W-30/40 is recommended for general use. The SA oil viscosity and service classification are in the API label on the oil container. We recommend that you use API SERVICE Category SF or higher class oil.

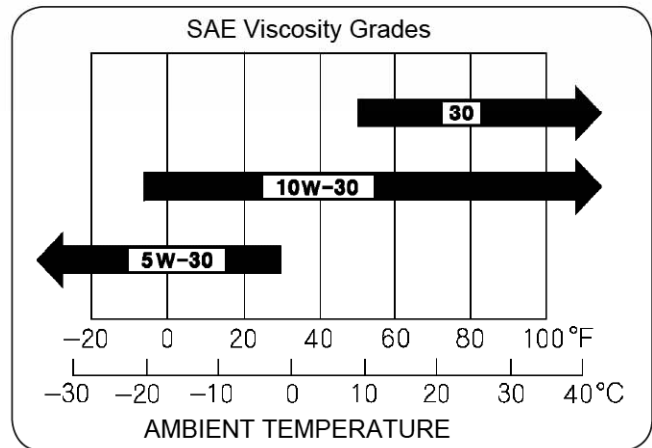

Figure 7

MAINTAINING AIR CLEANER

A dirty air filter will restrict air flow to the carburetor, reducing engine performance.

If you operate the engine in very dusty areas, clean the air filter more often than specified in the MAINTENANCE SCHEDULE.

Notice:



Operating the engine without element or with a damaged element will allow dirt to enter the engine, causing rapid engine wear.

1. Screw off air cleaner bolt and remove the cover.

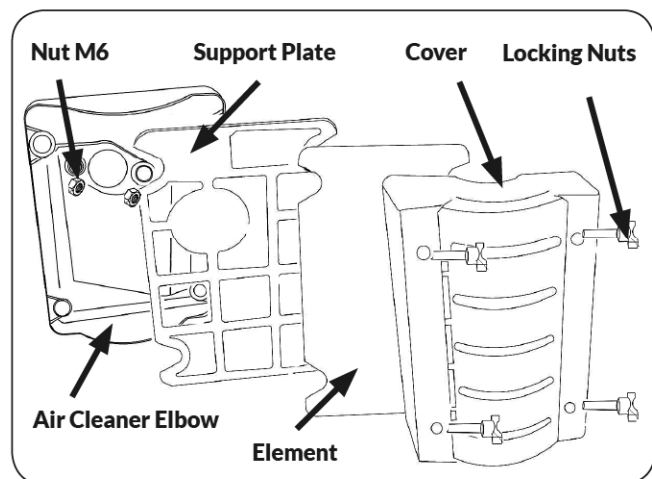

Figure 8

2. Remove foam element.

Check element and renew if damaged Wash foam element: Wash the cover and filter in warm, soapy water, rinse, and allow drying thoroughly. Or clean in nonflammable solvent and allow drying. Dip in clean engine oil, and then squeeze out all excess oil.

Empty the used oil from the air cleaner case, wash out any accumulated dirt with nonflammable solvent, and dry the case.

- Clean the air cleaner, cover and rubber gasket, preventing dust entering into carburetor.
- Reassemble the foam element, paying attention to rubber gasket underneath the element.
- Reassemble the air cleaner, and tighten the wing nut securely.

WASHING SEDIMENT CUP

(First check fuel tank for fuel, if having, drain the fuel in the fuel tank completely.)

- Remove the fuel sediment cup and O-ring.
- Wash the sediment cup and O-ring in nonflammable solvent, and dry them thoroughly.
- Place the O-ring in the fuel valve, and install the sediment cup. Tighten the sediment cup securely.
- Move the fuel valve to the ON position, and check for leaks. Replace the O-ring if there is any leakage.

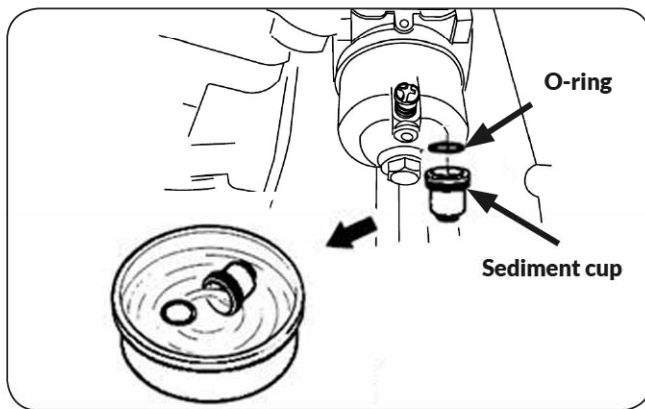

Figure 9

SPARK PLUG

Recommended spark plugs: E7RTC or other equivalents.



Notice:
An incorrect spark plug can cause engine damage.

- Disconnect the spark plug cap, and remove any dirt from around the spark plug area.
- Remove the spark plug with a spark plug wrench.

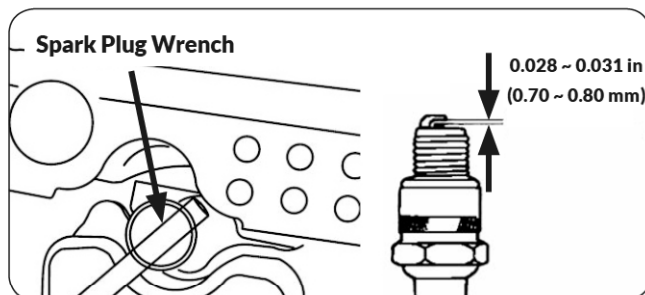

Figure 10

- Inspect the spark plug. Replace it if the electrodes are worn, or if the insulator is cracked or chipped.
- Measure the spark plug electrode gap with a suitable gauge. The gap should be 0.028 - 0.031 in (0.70 - 0.80 mm). Correct the gap, if necessary.
- Install the spark plug carefully, by hand, to avoid cross-threading.

- After the spark plug seats, tighten with a spark plug wrench to compress the seal.

If reinstalling the used spark plug, tighten 1/8 - 1/4 turn after the spark plug seats.

If installing a new spark plug, tighten 1/2 turn after the spark plug seats.



Notice:

A loose spark plug can overheat and damage the engine. Over tightening the spark plug can damage the threads in the cylinder head.

- Plug the spark plug wire onto the top of the spark plug.

ADJUSTING IDLE SPEED

- Start the engine outdoors, and allow it to warm up to operating temperature.
- Move the throttle lever to its slowest position.
- Turn the idle speed screw to obtain the standard idle speed. Standard idle speed: 2000±150 rpm.

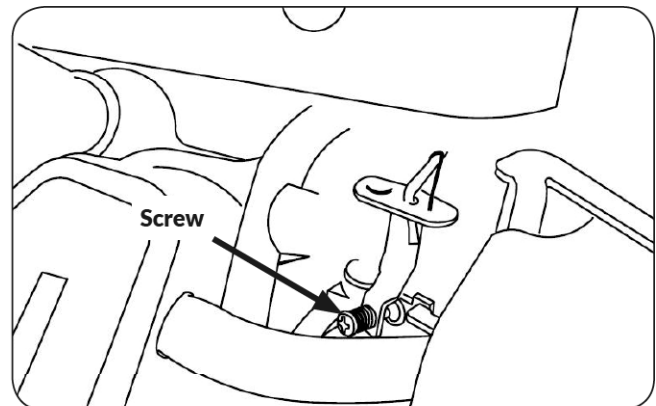

Figure 11

STORAGE

STORAGE PREPARATION

Proper storage preparation is essential for keeping your engine trouble free and looking good. The following steps will help to keep rust and corrosion from impairing your engine's function and appearance, and will make the engine easier to start after storage.

CLEANING

If the engine has been running, allow it to cool for at least half an hour before cleaning. Clean all exterior surfaces, touch up any damaged paint, and coat other areas that may rust with a light film of oil.

**Notice:**

Using a garden hose or pressure washing equipment can force water into the air cleaner or muffler opening. Water in the air cleaner will soak the air filter, and water that passes through the air filter or muffler can enter the cylinder, causing damage.

**Notice:**

Water contacting a hot engine can cause damage. If the engine has been running, allow it to cool for at least half an hour before washing.

DRAINING CARBURETOR

1. Place a container underneath the carburetor, and use funnel to avoid spattering.
2. Remove the drain plug and sediment cup, then, open the fuel valve.

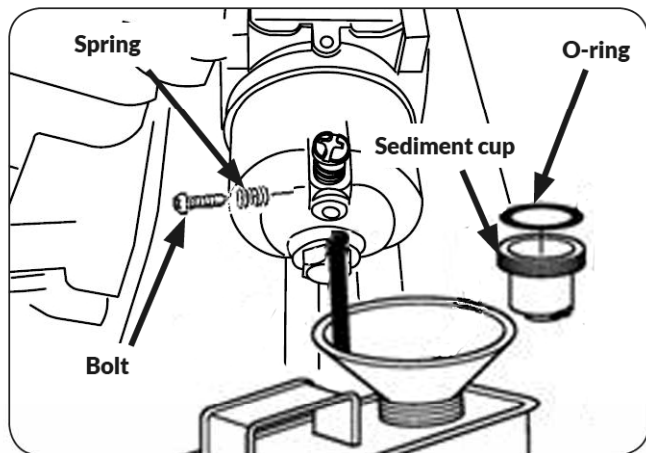

Figure 12

3. Immediately reassemble sediment cup and drain bolt after fuel has completely drained.
4. Change the engine oil.
5. Remove the spark plug.
6. Pour a tablespoon (5-10 cc) of clean engine oil into the cylinder.

7. Pull the starter rope several times to distribute the oil in the cylinder.
8. Reinstall the spark plugs.
9. Pull the starter rope slowly until resistance is felt. This will close the valves so moisture cannot enter the engine cylinder. Return the starter rope gently.
10. Plug the spark plug wire to the spark plug.

If your engine will be stored with gasoline in the fuel tank and carburetor, it is important to reduce the hazard of gasoline vapor ignition. Select a well-ventilated storage area away from any appliance that operates with a flame, such as a furnace, water heater, or clothes dryer. Also avoid any area with a spark-producing electric motor, or where power tools are operated.

If possible, avoid storage areas with high humidity, because that promotes rust and corrosion.

Be sure all fuel has been drained from the fuel tank, to reduce the possibility of fuel leakage.

Position the equipment so the engine is level. Tilting can cause fuel or oil leakage.

With the engine and exhaust system cool, cover the engine to keep out dust. A hot engine and exhaust system can ignite or melt some materials. Do not cover the with a plastic sheet or tarp. A nonporous cover will trap moisture around the engine, promoting rust and corrosion.

If equipped with a battery for an electric starter, recharge the battery once a month while the engine is in storage. This will help to extend the service life of the battery.

REMOVAL FROM STORAGE

Check your engine as described in the chapter **CHECK BEFORE OPERATION**.

If the fuel was drained during storage preparation, fill the tank with fresh gasoline. If you keep a container of gasoline for refueling, be sure that it contains only fresh gasoline. Gasoline oxidizes and deteriorates over time, causing hard starting.

If the cylinders were coated with oil during storage preparation, the engine may smoke briefly at startup. This is normal.

TRANSPORTING

If the engine has been running, allow it to cool for at least 15 minutes before loading the engine-powered equipment on the transport vehicle. A hot engine and exhaust system can burn you and can ignite some materials.

Keep the engine level when transporting to reduce the possibility of fuel leakage.

TROUBLESHOOTING

ENGINE WILL NOT START	Possible Cause	Correction
1. Electric starting: check battery	Battery discharged	Recharge battery
2. Check control positions	Fuel valve OFF Choke OPEN Engine switch OFF	Move lever to ON Move lever to CLOSE unless engine is warm. Turn engine switch to ON
3. Check fuel	Out of fuel Bad fuel; engine stored without treating or draining gasoline, or refueled with bad gasoline	Refuel Drain fuel tank and carburetor Refuel with fresh gasoline
4. Remove and inspect spark plugs	Spark plugs faulty, fouled, or improperly gapped Spark plugs wet with fuel (flooded engine)	Gap, or replace spark plugs Dry and reinstall spark plugs Start engine with throttle lever in FAST position
5. Take engine to an authorized servicing dealer, or refer to manual	Fuel filter clogged, carburetor malfunction, ignition malfunction, valve stuck, etc	Replace or repair faulty components as necessary

ENGINE LACKS POWER	Possible Cause	Correction
1. Check air filter	Filter element(s) clogged	Clean or replace filter element(s)
2. Check fuel	Out of fuel Bad fuel; engine stored without treating or draining gasoline, or refueled with bad gasoline	Refuel Drain fuel tank and carburetor Refuel with fresh gasoline
3. Take engine to an authorized servicing dealer, or refer to manual	Fuel filter clogged, carburetor malfunction, ignition malfunction, valve stuck, etc	Replace or repair faulty components as necessary

TECHNICAL & CONSUMER INFORMATION

CARBURETOR MODIFICATION FOR HIGH ALTITUDE OPERATION

At high altitude, the standard carburetor air-fuel mixture will be too rich. Performance will decrease, and fuel consumption will increase. A very rich mixture will also foul the spark plug and cause hard starting. Operation at an altitude that differs from that at which this engine was certified, for extended periods of time, may increase emissions.

High altitude performance can be improved by specific modifications to the carburetor. If you always operate your engine at altitudes above 5,000 feet (1,500 meters), have your servicing dealer perform this carburetor modification. This engine, when operated at high altitude with the carburetor modifications for high altitude use, will meet each emission standard throughout its useful life.

Even with carburetor modification, engine horsepower will decrease about 3.5% for each 1,000-foot (300-meter) increase in altitude. The effect of altitude on horsepower will be greater than this if no carburetor modification is made.

Notice:



When the carburetor has been modified for high altitude operation, the air-fuel mixture will be too lean for low altitude use. Operation at altitudes below 5,000 feet (1,500 meters) with a modified carburetor may cause the engine to overheat and result in serious engine damage. For use at low altitudes, have your servicing dealer return the carburetor to original factory specifications.

SOURCE OF EMISSIONS

The combustion process produces carbon monoxide, oxides of nitrogen, and hydrocarbons. Control of hydrocarbons and oxides of nitrogen is very important because, under certain conditions, they react to form photochemical smog when subjected to sunlight. Carbon monoxide does not react in the same way, but it is toxic.

This utilizes lean carburetor settings and other systems to reduce the emissions of carbon monoxide, oxides of nitrogen and hydrocarbons.

TAMPERING AND ALTERING

Tampering with or altering the emission control system may increase emissions beyond the legal limit. Among those acts that constitute tampering are:

- Removal or alteration of any part of the intake, fuel or exhaust systems.

- Altering or defeating the governor linkage or speed-adjusting mechanism to cause the engine to operate outside its design parameters.

PROBLEMS THAT MAY AFFECT EMISSIONS

If you are aware of any of the following symptoms, have your engine inspected and repaired by your servicing dealer.

- Hard starting or stalling after starting.
- Rough idle.
- Misfiring or backfiring under load.
- Afterburning (backfiring).
- Black exhaust smoke or high fuel consumption.

REPLACEMENT PARTS

We recommend the use of genuine parts whenever you have maintenance done. These original-design replacement parts are manufactured to the same standards as the original parts, so you can be confident of their performance. The use of replacement parts that are not of the original design and quality may impair the effectiveness of your emission control system.

A manufacturer of an aftermarket part assumes the responsibility that the part will not adversely affect emission performance. The manufacturer or rebuilder of the part must certify that use of the part will not result in a failure of the engine to comply with emission regulations.

MAINTENANCE

Follow the maintenance schedule. Remember that this schedule is based on the assumption that your machine will be used for its designed purpose. Sustained high-load or high-temperature operation, or use in unusually wet or dusty conditions, will require more frequent service.

ENGINE TUNE-UP

ITEM	SPECIFICATION
Spark plug gap	0.028-0.031 in (0.70 mm -0.80 mm)
Valve clearance	IN: 0.10 mm ~ 0.15 mm (cold) EX: 0.15 mm ~ 0.20 mm (cold)
Other specifications	No other adjustments needed

PUBLICATIONS

These publications will give you additional information for maintaining and repairing your engine. You may order them from your engine dealer.

QUICK REFERENCE INFORMATION

Engine Oil Spark plug gap	Type	SAE 5W-30, API SE or SF, for general use. Refer to engine oil recommendation.
	Capacity	0.35 L
Valve clearance Other specifications	Type	E7RTC or other equivalents.
	Gap	0.028 ~ 0.031 in (0.70 ~ 0.80 mm)
Maintenance	Each use	Check engine oil.
	First 20 hours	Change engine oil.
	Subsequent	Refer to the maintenance

WIRING DIAGRAMS

Non-electric starting engine with oil protection system.

	IG	E	ST	BAT
OFF	○ — ○			
ON				
START			○ — ○	

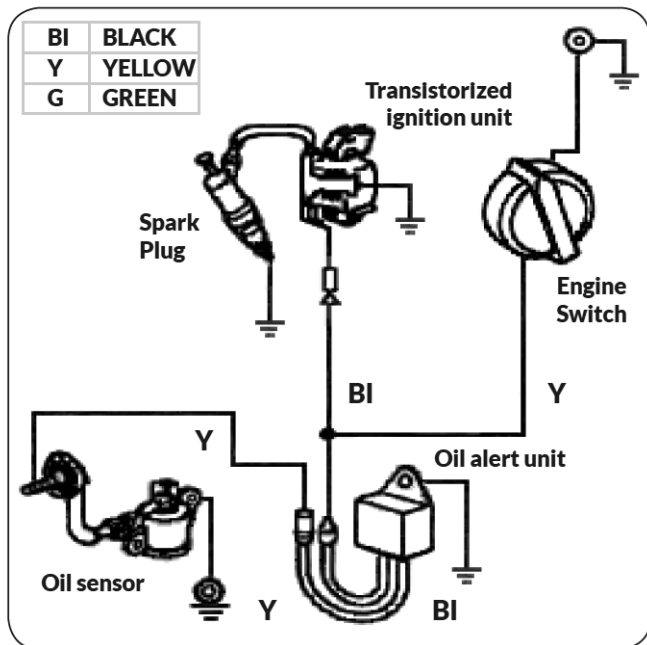

Figure 13

Tame the Great Outdoors®

