

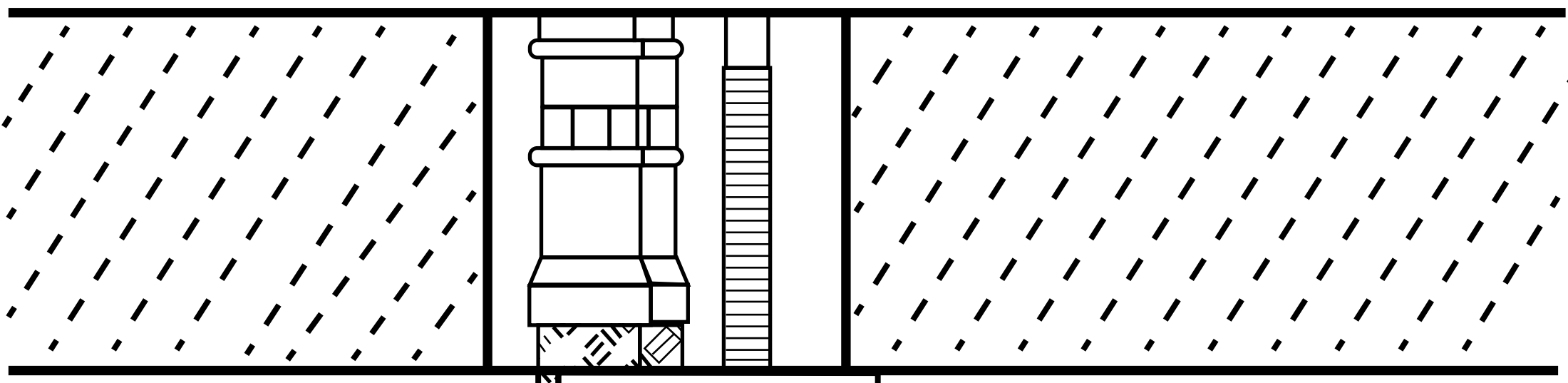

BASIN FAUCET

INSTRUCTION

BASIN FAUCET TYPE

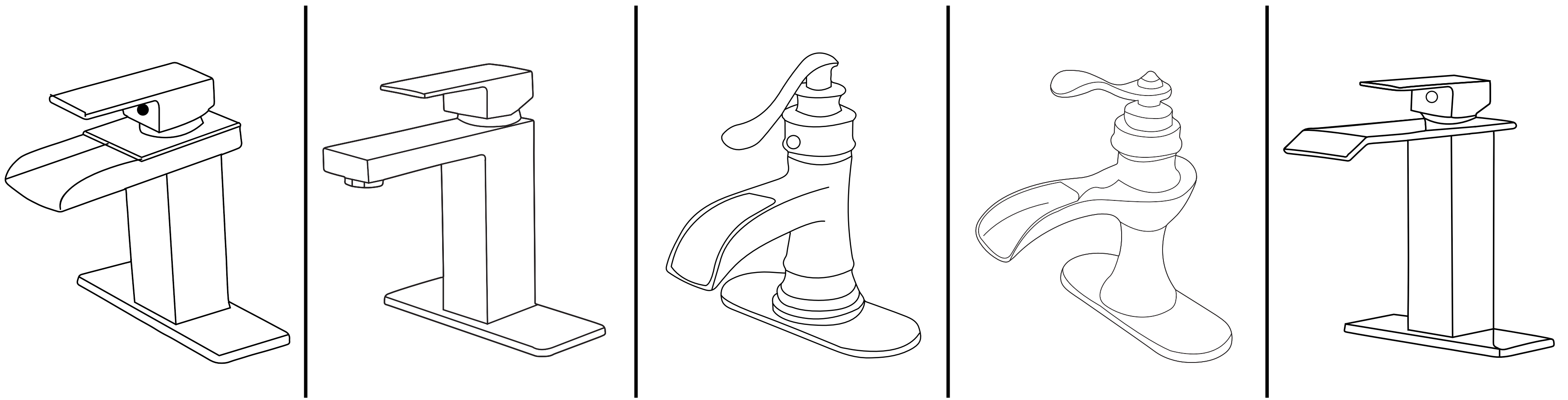

Run the hot and cold valve at least 15 seconds to it before connect.

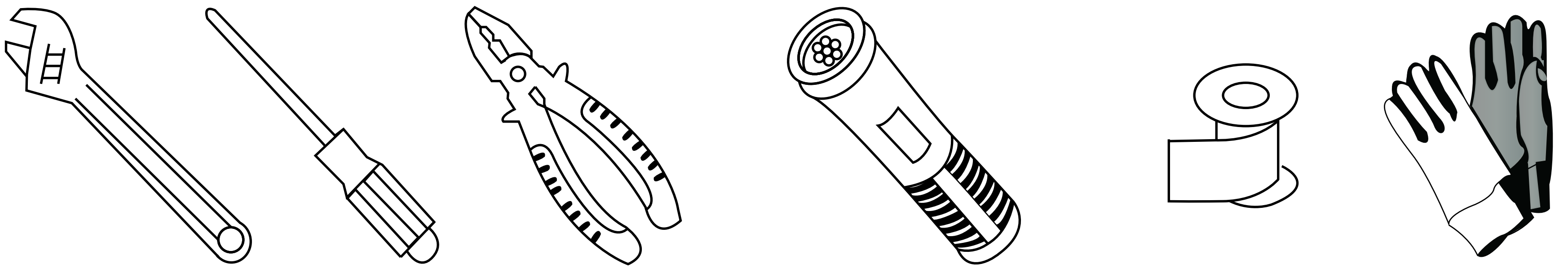
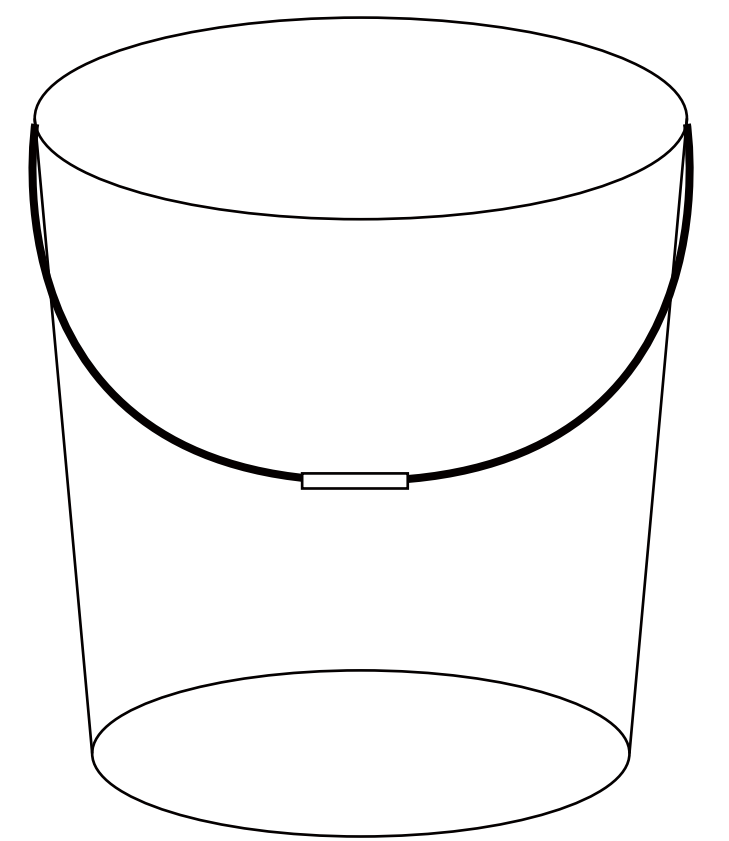
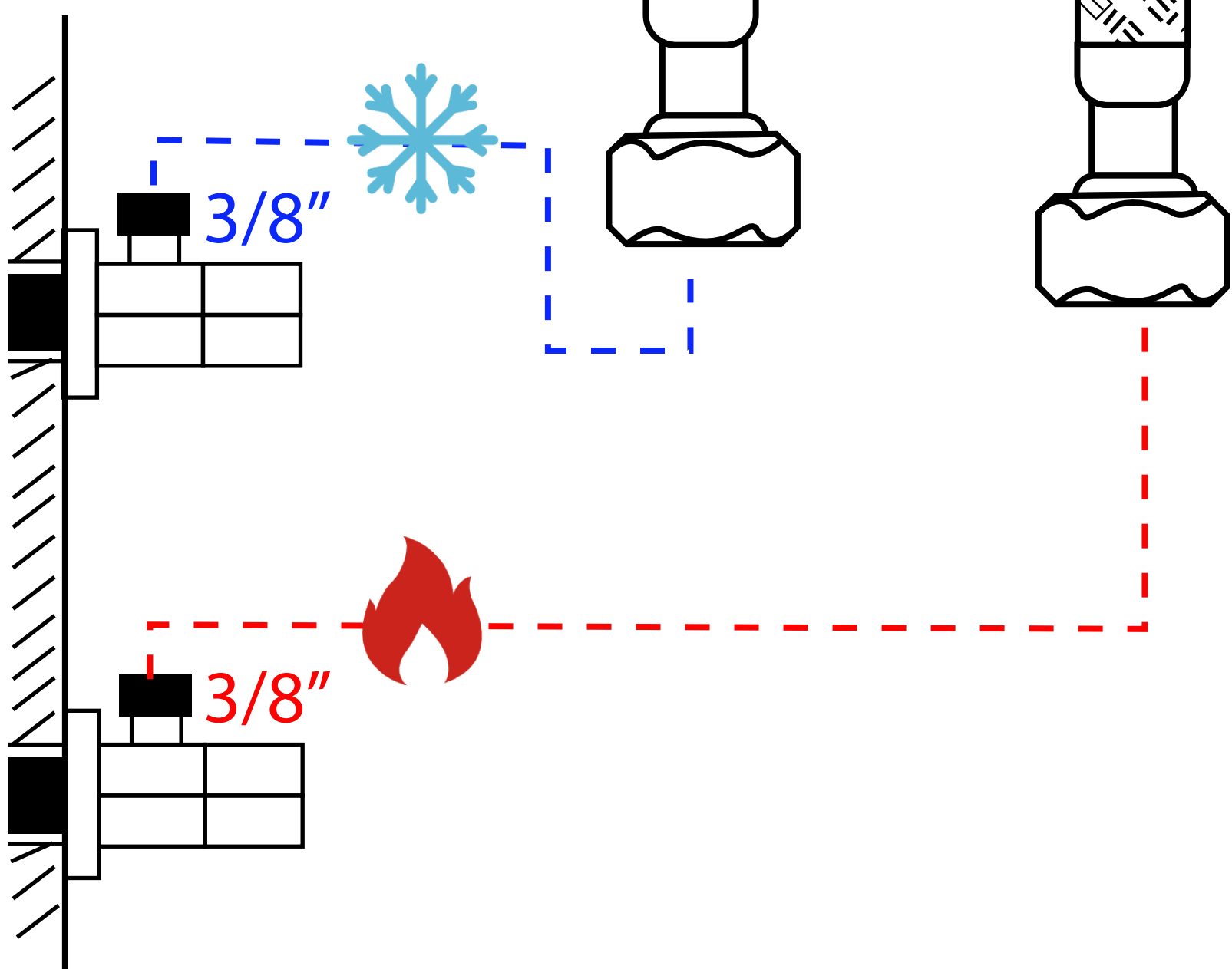

INSTALLATION STEPS

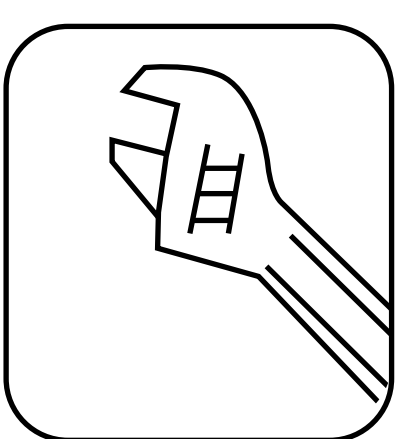

Flush piping system prior and after installation of fitting thoroughly.

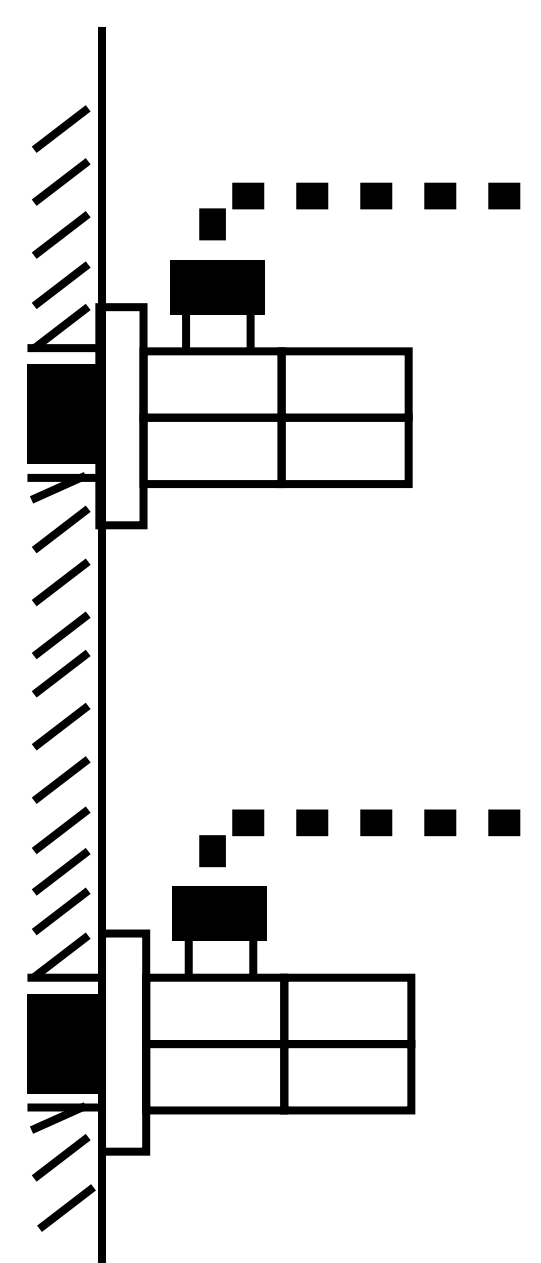
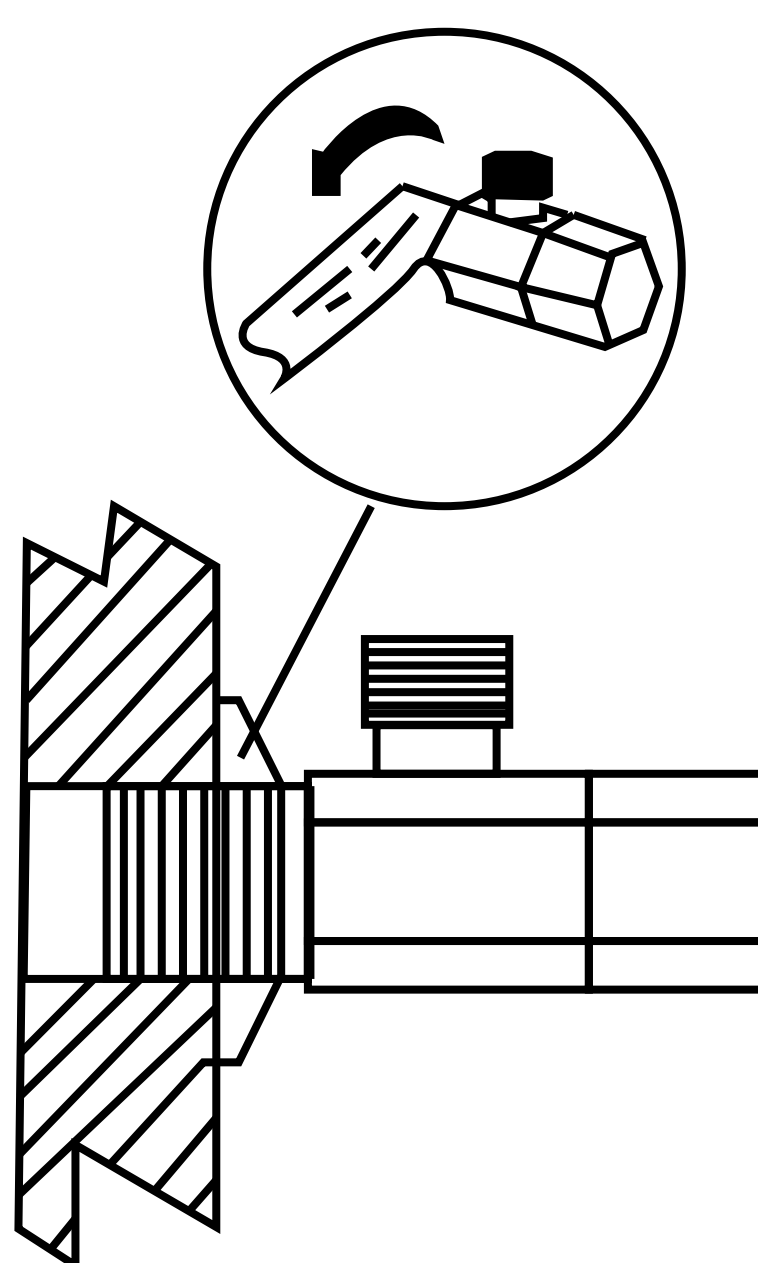
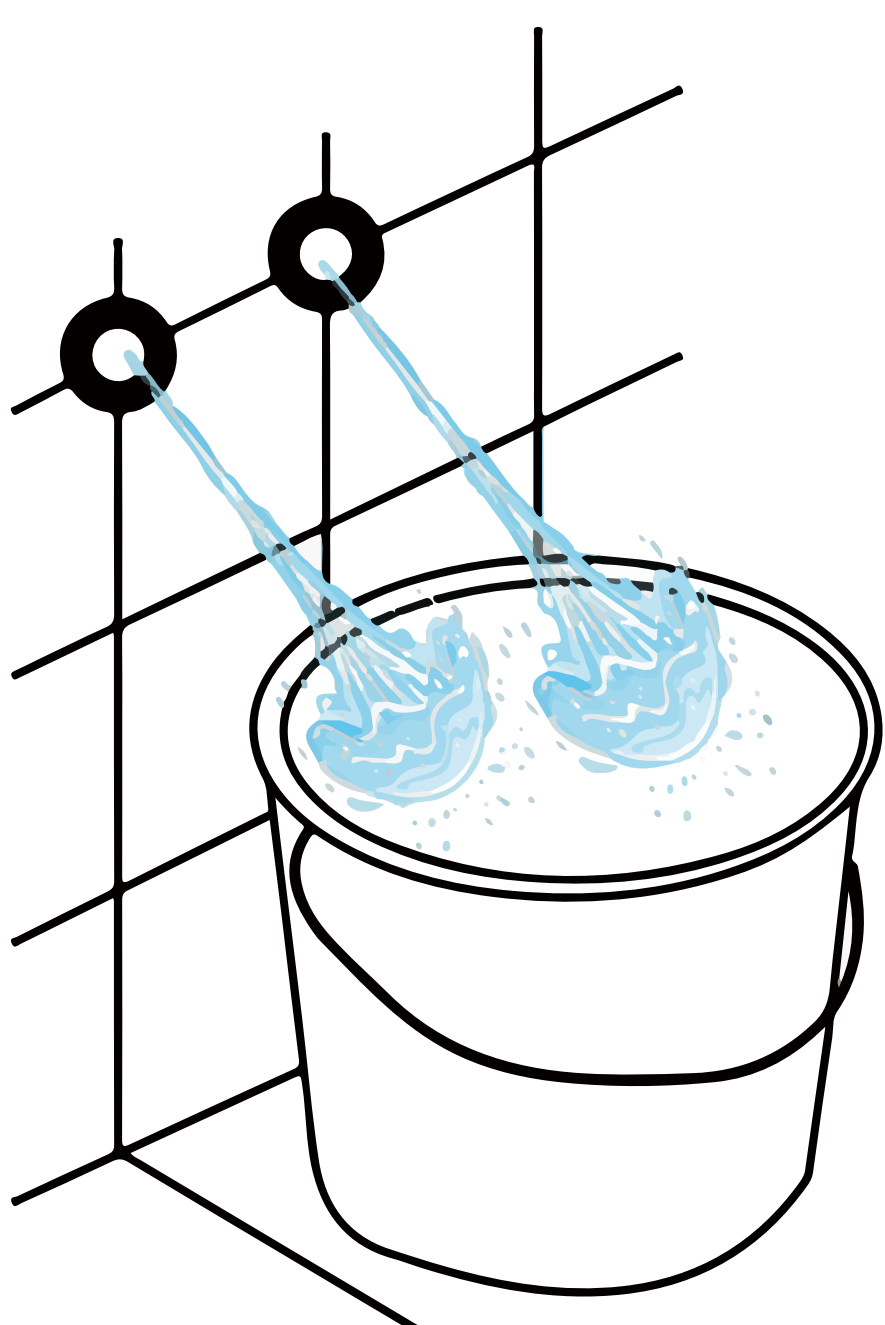

Single Screw

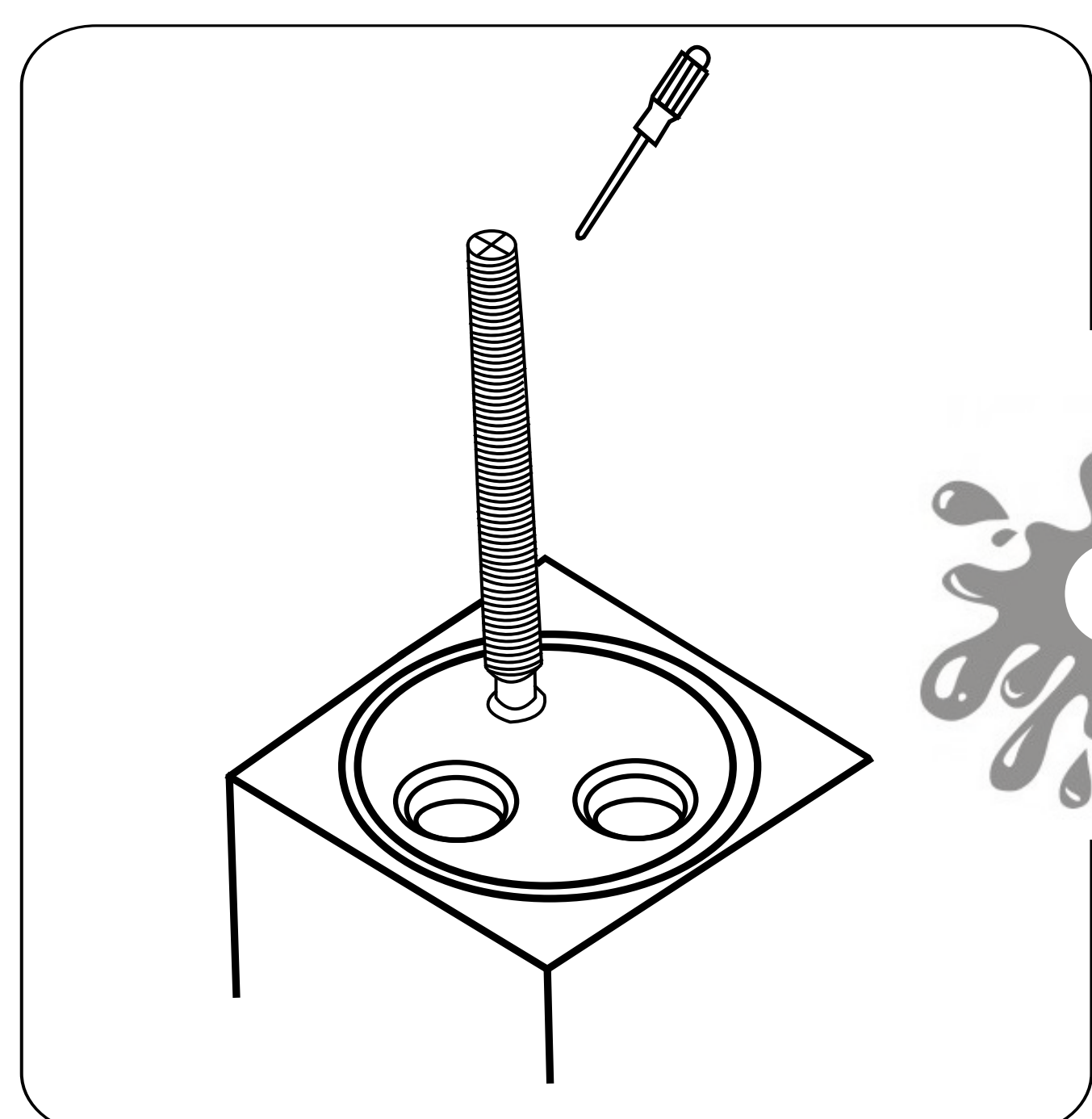

STEP



Install the screw

Install the hoses
in sequence

STEP

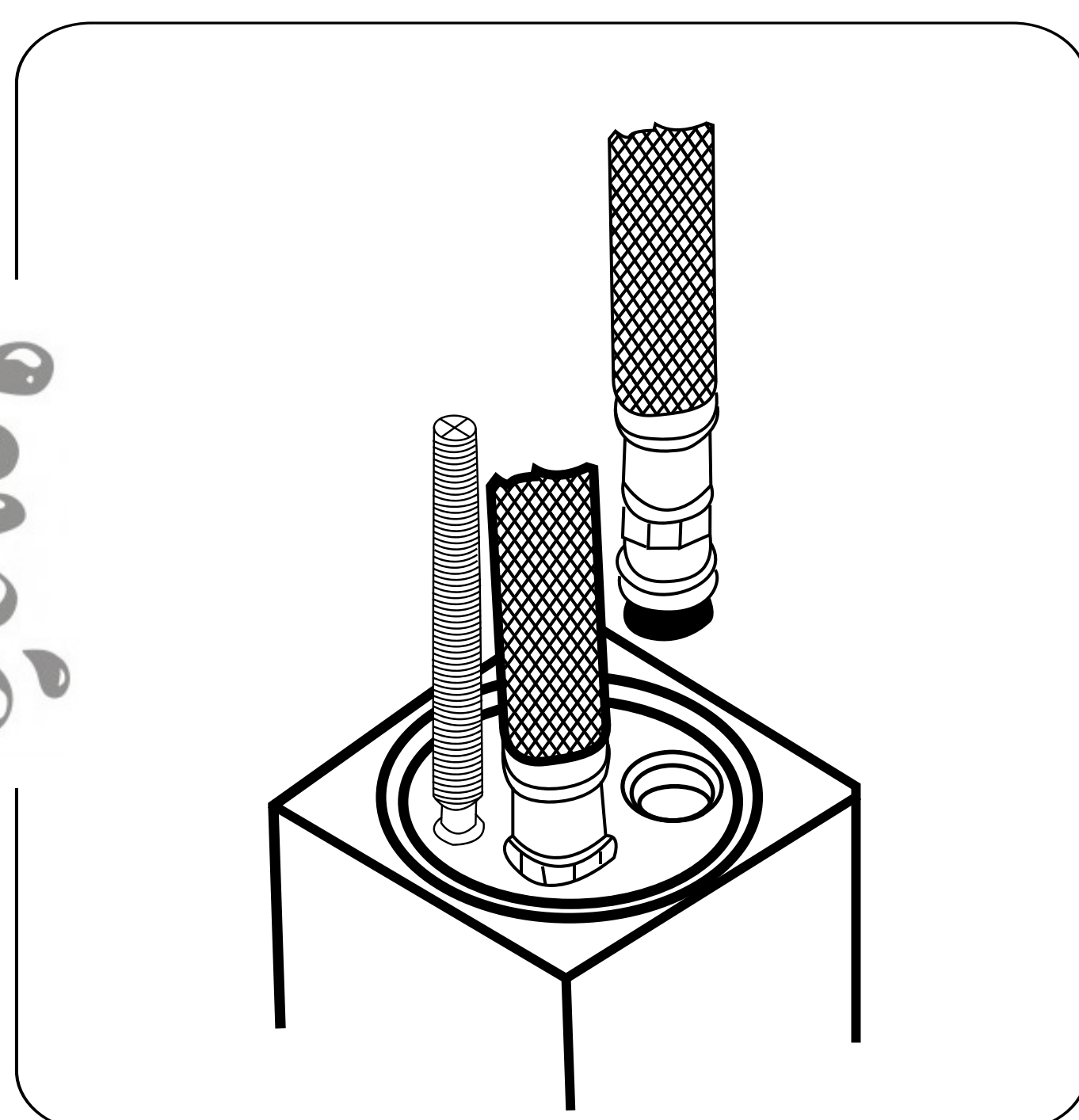

STEP



Place the O-Ring at the
bottom of the faucet

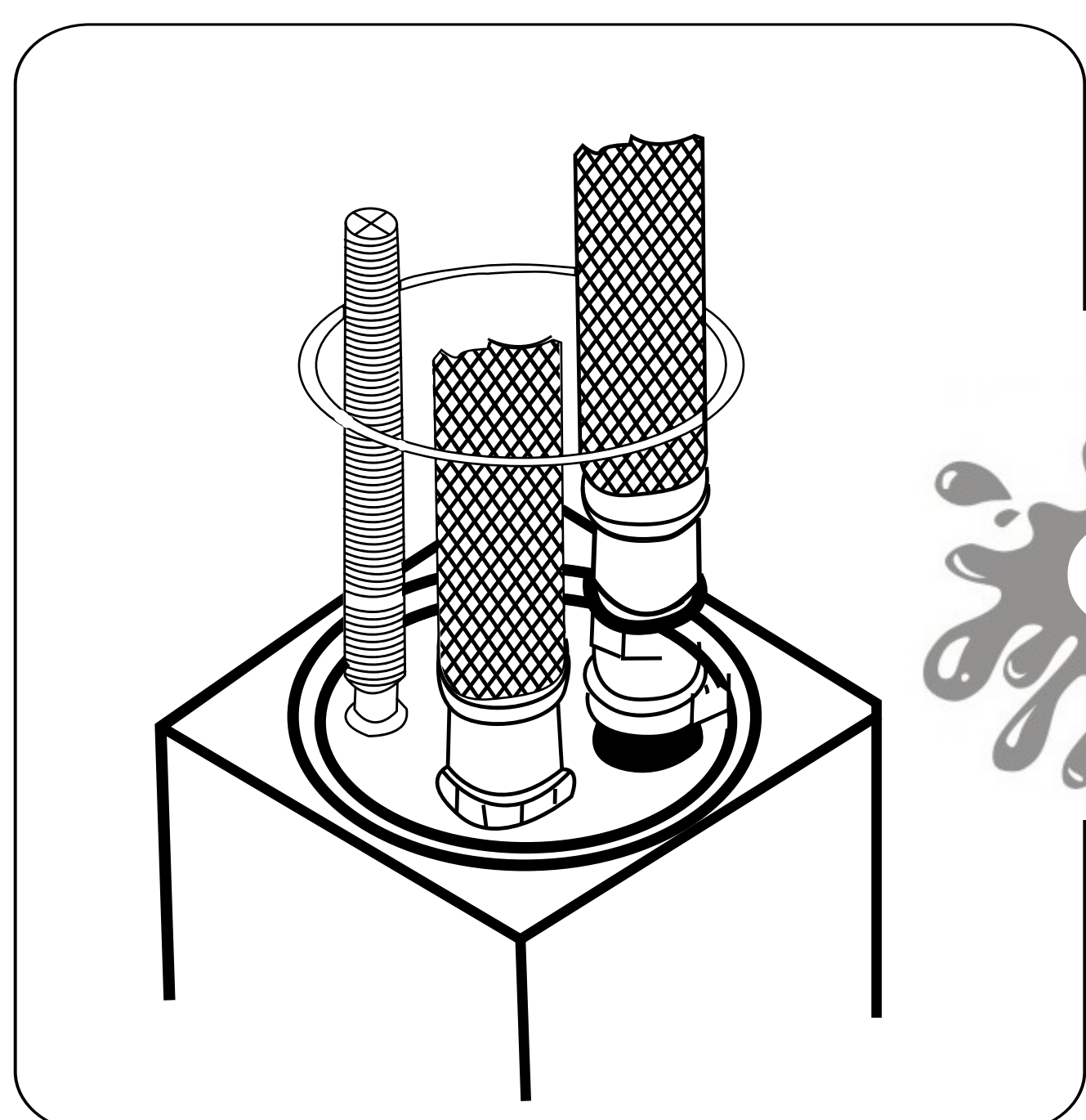

Put on the rubber gasket,
then tighten the locking nut.

STEP

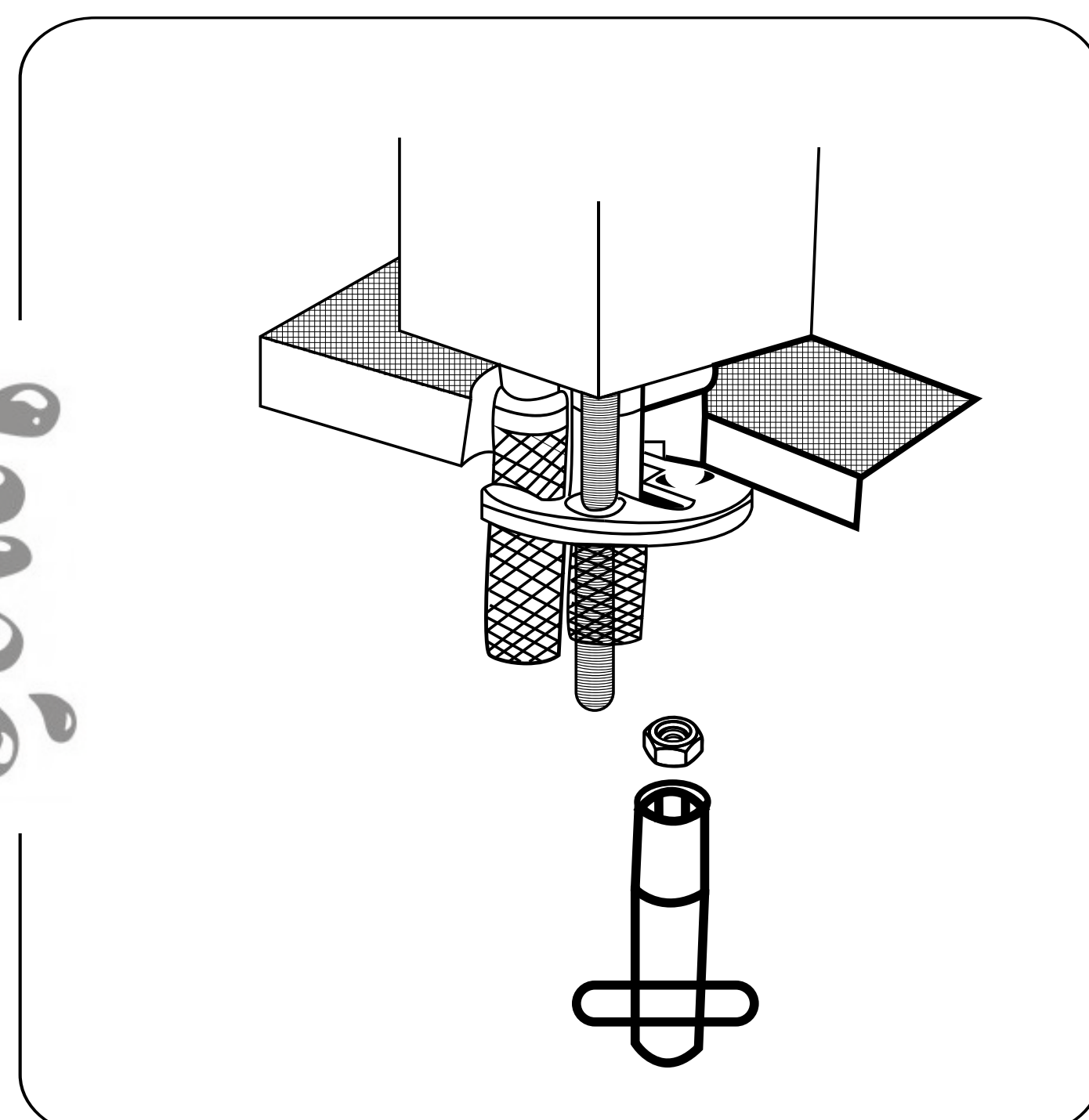

STEP



Connect the hose to triangle
valve to check the water
pressure and hermetic seal

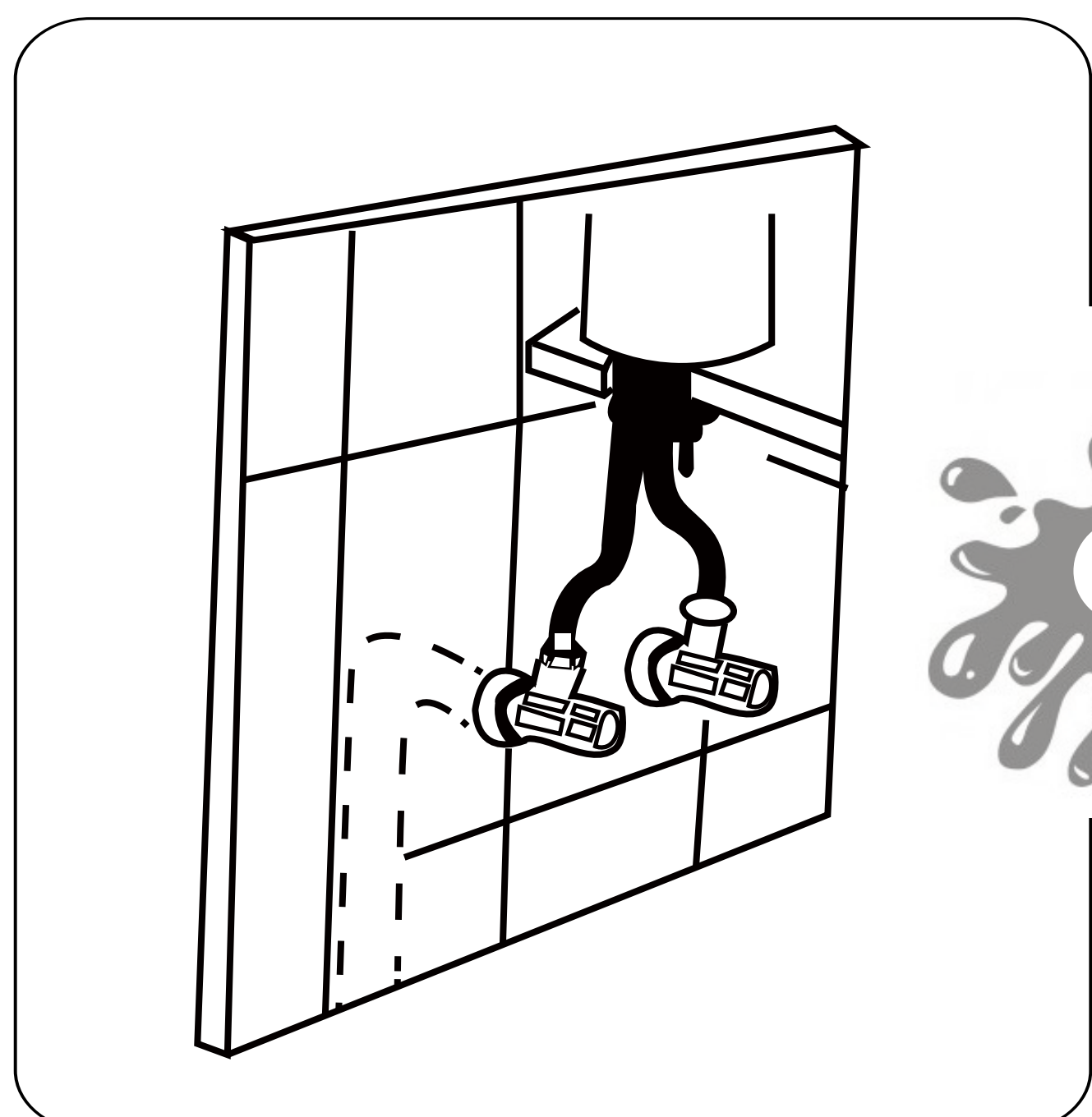

SPECIFICATION

Application:

Operation with unpressurized storage heaters is not possible.
Use for indoor public places and common residence.

Specifications:

Minimum Flow Pressure:	0.05MPa
Recommended Flow Pressure:	0.4MPa
Operating Pressure:	0.1~1.0MPa
Test Pressure:	1.6MPa
Maximum Hot Water:	90°C/194°F
Recommended Hot Water:	60°C
Environment Temperature:	30°C-60°C/86°F-140°F

If static pressure exceeds 0.5MPa, a pressure-reducing valve must be fitted.
Avoid major pressure differences between hot and cold water supply

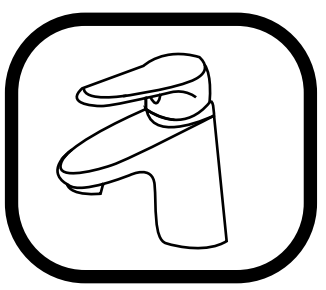

Function:

Check connections for leaks and check function of fitting.

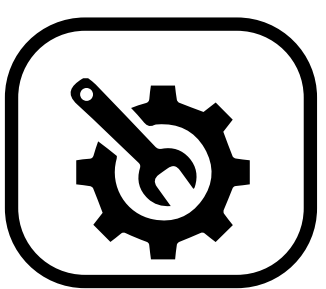

Maintenance:

Inspect and clean all components and replace if necessary. Shut off water supply for maintenance work.



Note:

When installing the cartridge, ensure that the seals are correctly seated. Tighten the screw evenly and alternately.

MAINTENANCE

CAUTION: Always turn water OFF before removing existing or disassembling the faucet. Open faucet handle to relieve water pressure and insure that complete water shut-off has been accomplished.



To keep the surface clean and bright, please clean the faucet regularly. please abide by the following procedures.

1. Use rinsing water and soft cloth, clean bilge and bilge membrane on the surface to the best of the abilities.
2. Cleaned the residue with the following cleansers only.
 - ✓ Soft liquid cleanser.
 - ✓ Colorless glass cleanser, totally soluble powder cleanser without abrasive capability. (Mixed by instructions)
 - ✗ Never use cleanser, emery cloth or handkerchief which can rub.
 - ✗ Never use cleanser containing abrasive cleansers, ammonia, bleach, acids, waxes, alcohol, solvents or other products not recommended for chrome.
 - ✗ Never use silicone gel containing acetic acid.
3. After cleaning, rinse to flush cleanser off and dry with soft cloth.
4. Carefully dismantle the aerator regularly, rinse under clean water until loose debris is cleared. (Except the waterfall faucet)