

Wall Bracket Installation Instruction

<p>① Mount crossbar securely to wall with anchor screws and bolts. Insure mounting surface is suitable for bracket and add extra wall supports if necessary.</p> <p>CAUTION: Crossbar is only to help with proper mounting of arms and not load bearing. Crossbar is not designed to hold weight of arms and equipment. Arms must be secured to wall separately.</p>	<p>② Install arm on the the crossbar. Measure and mark proper distance for arms on cross bar.</p>	<p>③ Double check bracket is level and arm alignment is correct before any anchor drilling. Mark hole locations on wall and move arms to the side to drill anchor holes.</p>	<p>④ Completely unfold arms and check all securing hardware nuts and washers.</p>	<p>⑤ Secure arm mounting bolts with at least three bolts and anchors per arm after all bolts are installed. Recheck all bolts and nuts for tightness and insure everything is secure before mounting any equipment.</p> <p>Note: Slight rearward tilt to wall is recommended for safety purposes.</p>
---	---	--	---	--

①

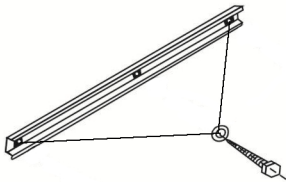

②

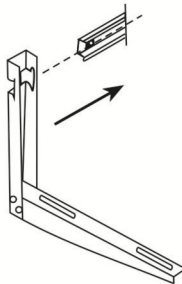

③

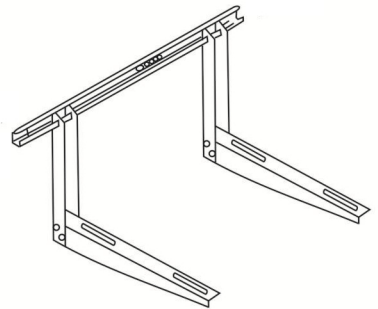

④

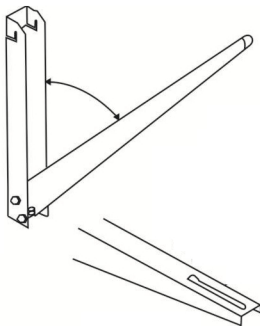

⑤

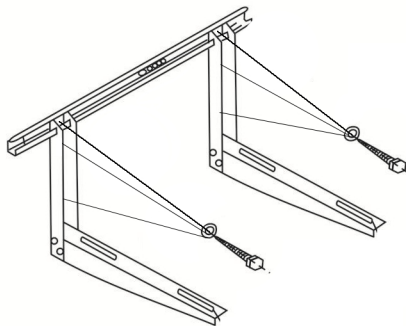

Note:

1. Ensure that the wall bracket is mounted properly to handle applied loads as wall construction may vary.
2. The wall bracket must be securely fixed to wall with all screws fastened tightly.
3. Do not make any modification to bracket assembly or fixings.
4. Check that all screws and bolts are secured tightly before placing the unit on it.
5. Bracket is designed for masonry wall mount, for stud wall mount proper blocking must be made between studs to insure proper wall bracing will accommodate bracket weight load.

Disclaimer.

Your use and application of our products requires the customer to be responsible for product application, installation and compliance with local and environmental regulations that are applicable including all practices of safety and safety regulations. These products are provided as is without any guarantees or warranty. Ductless supply makes no warranties of any kind, either express or implied, including but not limited to warranties of merchantability, fitness for a particular purpose, of title, or of infringement of third party rights. Use of the product by a user is at the user's risk. In case of claim or dispute, all cases will be considered in accordance with our General Conditions of Sale.