

**DX Series 41 in. W x 25 in. D
Powder-Coated Steel Hutch**

**DX Series 72 in. W x 21 in. D Powder-Coated Steel Hutch
with Power Tool Rack Accessory**

shown assembled on

DX722117RC or DX7217RC 72 in. 17 Drawer Roller Cabinet (sold separately)

DX Series 72 in & 41 in Extreme Power Workstation Models:

DX722101HC

DX7201HC

DX412501HC

DX4101HC

Extreme Tools, Inc.
740 Frontenac Road
Naperville, Illinois 60563
630.369.9303
www.ExtremeTools.com

Sales@extremetools.net
CustomerService@extremetools.net

Parts Diagram for DX722101HC, DX7201HC, DX412501HC, DX4101HC

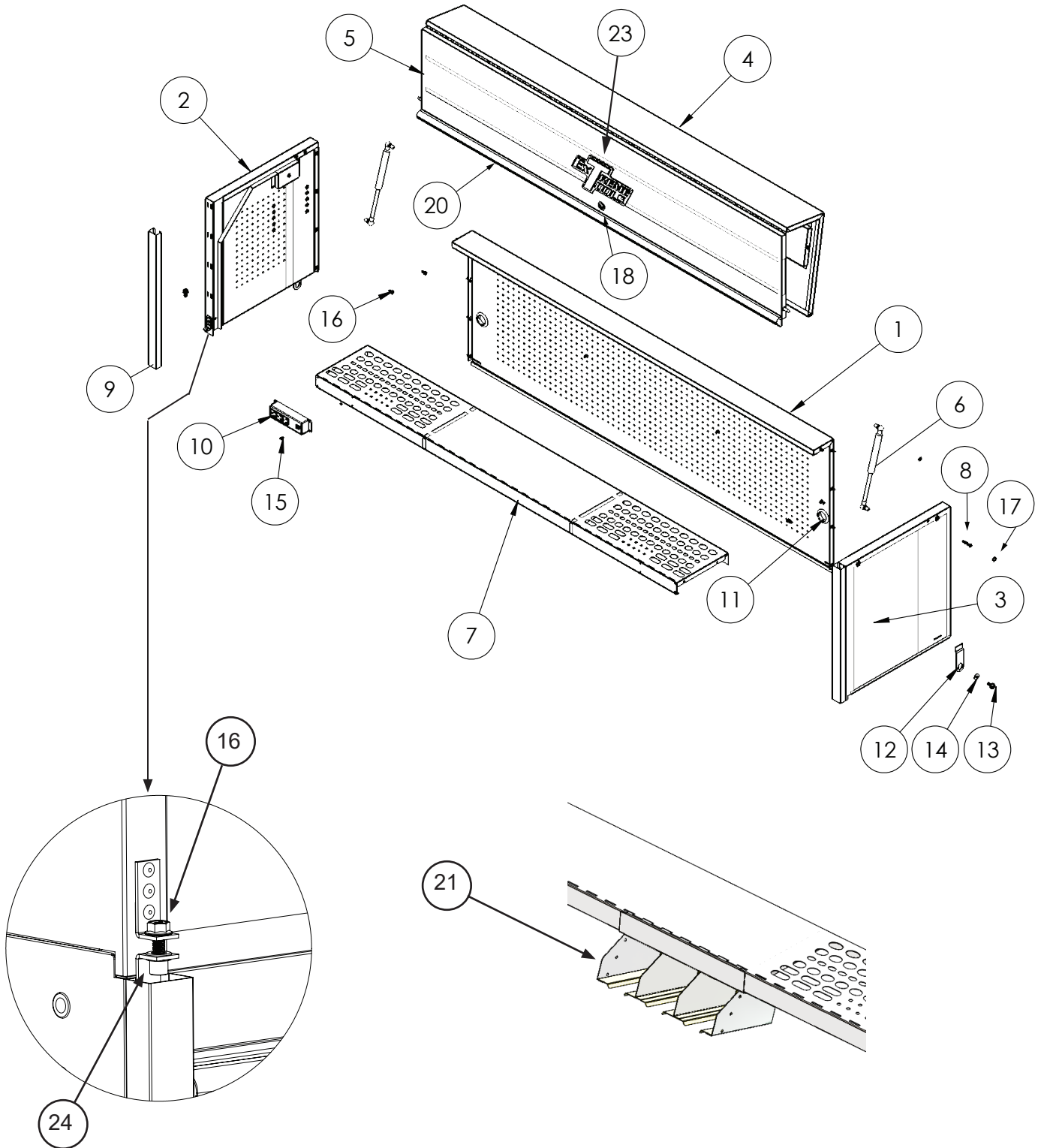

Replacement keys may be ordered using the code that appears on the face of the lock.

To order replacement parts, have the part number, tool box color and quantity ready. If under warranty, the serial number is **REQUIRED** to get replacement parts.

Not all parts are available under warranty and may be purchased separately.

DX722101HC or DX7201HC PARTS LIST

ITEM #	PART NUMBER	DESCRIPTION	QTY.
1	Z-7221HC-01 BK	7221 Hutch Top-Back panel, BK	1
1	Z-7221HC-01 BL	7221 Hutch Top-Back panel, BL	1
1	Z-7221HC-01 GN	7221 Hutch Top-Back panel, GN	1
1	Z-7221HC-01 MB	7221 Hutch Top-Back panel, MB	1
1	Z-7221HC-01 OR	7221 Hutch Top-Back panel, OR	1
2	Z-7221HC-02 BK	DX 21" Side panel, Left, Black	1
2	Z-7221HC-02 BL	DX 21" Side panel, Left, Blue	1
2	Z-7221HC-02 GN	DX 21" Side panel, Left, Green	1
2	Z-7221HC-02 MB	DX 21" Side panel, Left, Matte Black	1
2	Z-7221HC-02 OR	DX 21" Side panel, Left, Orange	1
3	Z-7225HC-08 BK	DX 21" Side panel, Right, Black	1
3	Z-7225HC-08 BL	DX 21" Side panel, Right, Blue	1
3	Z-7225HC-08 GN	DX 21" Side panel, Right, Green	1
3	Z-7225HC-08 MB	DX 21" Side panel, Right, Matte Black	1
3	Z-7225HC-08 OR	DX 21" Side panel, Right, Orange	1
4	Z-7225HC-10 BK	7225 Hutch Top-Front panel, Black	1
4	Z-7225HC-10 BL	7225 Hutch Top-Front panel, Blue	1
4	Z-7225HC-10 GN	RX7225 Hutch Top-Front panel, Green	1
4	Z-7225HC-10 MB	7225 Hutch Top-Front panel, Matte Black w/ black handle	1
4	Z-7225HC-10 OR	7225 Hutch Top-Front panel, Orange	1
5	Z-DX7221HC-13 BKBL	DX7221 Hutch Lower-Front Lid Assy, BKBL	1
5	Z-DX7221HC-13 BKRD	DX7221 Hutch Lower-Front Lid Assy, BKRD	1
5	Z-DX7221HC-13 BLBK	DX7221 Hutch Lower-Front Lid Assy, BLBK	1
5	Z-DX7221HC-13 GNBK	DX7221 Hutch Lower-Front Lid Assy, GNBK	1
5	Z-DX7221HC-13 MBBK	DX7221 Hutch Lower-Front Lid Assy, MBBK	1
5	Z-DX7221HC-13 ORBK	DX7221 Hutch Lower-Front Lid Assy, ORBK	1
6	ZST300400M6	Strut door support for a RX722501, RX723001HC & DX722101HC hutch, M6 stud ball joint, 40 kg. force (Older design)	2
6	ZST300400M8	Strut door support for a RX722501, RX723001HC & DX722101HC hutch, M8 stud ball joint, 40 kg. force (New design)	2
*	ZRB-10 OD	Rubber bumper, 10 mm OD	2
7	Z-7225HC-19 BK	Hutch adjustable shelf for 21 or 25 deep, BK	1
7	Z-7225HC-19 BL	Hutch adjustable shelf for 21 or 25 deep, BL	1
7	Z-7225HC-19 GN	Hutch adjustable shelf for 21 or 25 deep, GN	1
7	Z-7225HC-19 MB	Hutch adjustable shelf for 21 or 25 deep, MB	1
7	Z-7225HC-19 OR	Hutch adjustable shelf for 21 or 25 deep, OR	1
8	ZM6SCSH-35	M6 x 35 mm Socket Head Screw, for RX/DX HC door hinge	2
9	Z-TRFDX560-BL	DX CH/HC FRONT TRIM, 560 MM LG, BLUE	2
9	Z-TRFDX560-RD	DX CH/HC FRONT TRIM, 560 MM LG, RED	2
9	Z-TRFDX560-BK	DX CH/HC FRONT TRIM, 560 MM LG, BLACK	2

**DX722101HC or DX7201HC
PARTS LIST Continued**

ITEM #	PART NUMBER	DESCRIPTION	QTY.
10	Z-PS333032	POWER STRIP, 2.1A USBX2, 120VX3	1
11	ZRG-38	RUBBER GROMMET - 38 MM ID	2
12	Z-7225HC-22 BK	Hutch-RC Connecting Bracket for sides, BK	2
12	Z-7225HC-22 BL	Hutch-RC Connecting Bracket for sides, BL	2
12	Z-7225HC-22 GN	Hutch-RC Connecting Bracket for sides, GN	2
12	Z-7225HC-22 MB	Hutch-RC Connecting Bracket for sides, MB	2
12	Z-7225HC-22 OR	Hutch-RC Connecting Bracket for sides, OR	2
13	ZM8SCHX-16 BK	M8X16 Hex Bolts, Black	2
13	ZM8SCHX-16 BL	M8X16 Hex Bolts, Blue	2
13	ZM8SCHX-16 GN	M8X16 Hex Bolts, Green	2
13	ZM8SCHX-16 MB	M8X16 Hex Bolts, Matte Black	2
13	ZM8SCHX-16 OR	M8X16 Hex Bolts, Orange	2
14	ZM8WAFT-BK	M8 flat washer, Black	2
14	ZM8WAFT-BL	M8 flat washer, Blue	2
14	ZM8WAFT-GN	M8 flat washer, Green	2
14	ZM8WAFT-MK	M8 flat washer, Matte Black	2
14	ZM8WAFT-OR	M8 flat washer, Orange	2
15	ZM4SCPH-12	PAN HEAD M4 SCREWS, 12 MM LONG for power strip	4
16	ZM6SCPH-12	M6 X 12MM SCREW, Pan head	20
17	Z-ECM13	Hole plug for RX/DX hutch pivot hole	2
18	Z-LK EX01-04	SEE KEY CODE ON LOCK (EX01-04)	1
19	Z-7221HC-07 BL	DX Hutch/Chest Vertical Trim, BL	2
19	Z-7221HC-07 RD	DX Hutch/Chest Vertical Trim, RD	2
19	Z-7221HC-07 BK	DX Hutch/Chest Vertical Trim, BK	2
20	Z-DPDX1739-BL	DX72 Hutch lid pull, Blue	1
20	Z-DPDX1739-RD	DX72 Hutch lid pull, Red	1
20	Z-DPDX1739-BK	DX72 Hutch lid pull, Black	1
20A	ZM4NTSR	M4 Serrated nut for DX drawer pull handle/chest lid handle	8
*	ZM5MSPH-16	M5 X 16 MM Pan Head Mach. Screw for power tool adaptor	1
21	ACPTRBK	Adjustable Power Tool Rack, Black	1
21	ACPTRBL	Adjustable Power Tool Rack, Blue	1
21	ACPTRGN	Adjustable Power Tool Rack, Green	1
21	ACPTRMB	Adjustable Power Tool Rack, Matte Black	1
21	ACPTROR	Adjustable Power Tool Rack, Orange	1
23	Z-LGL	Extreme Tools Logo	1
24	Z-BRJHOOKDXHC	J hook bracket for mounting DX HC side panel to DXRC,	2
		*Not Shown on Drawing	

DX412501HC or DX4101HC PARTS LIST

ITEM #	PART NUMBER	DESCRIPTION	QTY.
1	Z-4125HC-01 BK	RX/DX 4125 Hutch Top-Back panel, BK	1
1	Z-4125HC-01 BL	RX/DX 4125 Hutch Top-Back panel, BL	1
1	Z-4125HC-01 GN	RX/DX 4125 Hutch Top-Back panel, GN	1
1	Z-4125HC-01 MB	RX/DX 4125 Hutch Top-Back panel, MB	1
1	Z-4125HC-01 OR	RX/DX 4125 Hutch Top-Back panel, OR	1
2	Z-D25HC-02 BK	DX 25" Side panel, Left, Black	1
2	Z-D25HC-02 BL	DX 25" Side panel, Left, Blue	1
2	Z-D25HC-02 GN	DX 25" Side panel, Left, Green	1
2	Z-D25HC-02 MB	DX 25" Side panel, Left, Matte Black	1
2	Z-D25HC-02 OR	DX 25" Side panel, Left, Orange	1
3	Z-D25HC-08 BK	DX 25" Side panel, Right, Black	1
3	Z-D25HC-08 BL	DX 25" Side panel, Right, Blue	1
3	Z-D25HC-08 GN	DX 25" Side panel, Right, Green	1
3	Z-D25HC-08 MB	DX 25" Side panel, Right, Matte Black	1
3	Z-D25HC-08 OR	DX 25" Side panel, Right, Orange	1
4	Z-41WHC-10 BK	41" W Hutch Top-Front panel, Black	1
4	Z-41WHC-10 BL	41" W Hutch Top-Front panel, Blue	1
4	Z-41WHC-10 GN	41" W Hutch Top-Front panel, Green	1
4	Z-41WHC-10 MB	41" W Hutch Top-Front panel, Matte Black w/ black handle	1
4	Z-41WHC-10 OR	41" W Hutch Top-Front panel, Orange	1
5	Z-D41HC-13 BKBL	DX 41" Hutch Lower-Front Lid Assy, BKBL	1
5	Z-D41HC-13 BKRD	DX 41" Hutch Lower-Front Lid Assy, BKRD	1
5	Z-D41HC-13 BLBK	DX 41" Hutch Lower-Front Lid Assy, BLBK	1
5	Z-D41HC-13 GNBK	DX 41" Hutch Lower-Front Lid Assy, GNBK	1
5	Z-D41HC-13 MBBK	DX 41" Hutch Lower-Front Lid Assy, MBBK	1
5	Z-D41HC-13 ORBK	DX 41" Hutch Lower-Front Lid Assy, ORBK	1
6	ZST300260M6	Strut door support for a RX412501HC & DX412501HC hutch, M6 stud ball joint, 26 kg. force (Older design)	2
6	ZST300260M8	Strut door support for a RX412501 & DX412501HC hutch, M8 stud ball joint, 40 kg. force (New design)	2
	ZRB-10 OD	Rubber bumper, 10 mm OD	2
7	Z-41HC-19 BK	41" RX/DX Hutch adjustable shelf for 21 or 25 deep, BK	1
7	Z-41HC-19 BL	41" RX/DX Hutch adjustable shelf for 21 or 25 deep, BL	1
7	Z-41HC-19 GN	41" RX/DX Hutch adjustable shelf for 21 or 25 deep, GN	1
7	Z-41HC-19 MB	41" RX/DX Hutch adjustable shelf for 21 or 25 deep, MB	1
7	Z-41HC-19 OR	41" RX/DX Hutch adjustable shelf for 21 or 25 deep, OR	1
8	ZM6SCSH-35	M6 x 35 mm Socket Head Screw, for RX/DX HC door hinge	2
9	Z-TRFDX560-BL	DX CH/HC FRONT TRIM, 560 MM LG, BLUE	2
9	Z-TRFDX560-RD	DX CH/HC FRONT TRIM, 560 MM LG, RED	2
9	Z-TRFDX560-BK	DX CH/HC FRONT TRIM, 560 MM LG, BLACK	2
10	Z-PS333032	POWER STRIP, 2.1A USBX2, 120VX3	1
11	ZRG-38	RUBBER GROMMET - 38 MM ID	2

**DX412501HC or DX4101HC
PARTS LIST Continued**

ITEM #	PART NUMBER	DESCRIPTION	QTY.
12	Z-RDXHC-22 BK	Hutch-RC Connecting Bracket for sides, BK	2
12	Z-RDXHC-22 BL	Hutch-RC Connecting Bracket for sides, BL	2
12	Z-RDXHC-22 GN	Hutch-RC Connecting Bracket for sides, GN	2
12	Z-RDXHC-22 MB	Hutch-RC Connecting Bracket for sides, MB	2
12	Z-RDXHC-22 OR	Hutch-RC Connecting Bracket for sides, OR	2
13	ZM8SCHX-16 BK	M8X16 Hex Bolts, Black	2
13	ZM8SCHX-16 BL	M8X16 Hex Bolts, Blue	2
13	ZM8SCHX-16 GN	M8X16 Hex Bolts, Green	2
13	ZM8SCHX-16 MB	M8X16 Hex Bolts, Matte Black	2
13	ZM8SCHX-16 OR	M8X16 Hex Bolts, Orange	2
14	ZM8WAFT-BK	M8 flat washer, Black	2
14	ZM8WAFT-BL	M8 flat washer, Blue	2
14	ZM8WAFT-GN	M8 flat washer, Green	2
14	ZM8WAFT-MK	M8 flat washer, Matte Black	2
14	ZM8WAFT-OR	M8 flat washer, Orange	2
15	ZM4SCPH-12	PAN HEAD M4 SCREWS, 12 MM LONG for power strip	4
16	ZM6SCPH-12	M6 X 12MM SCREW, Pan head	20
17	Z-ECM13	Hole plug for RX/DX hutch pivot hole	2
18	Z-LK EX01-04	SEE KEY CODE ON LOCK (EX01-04)	1
19	Z-7221HC-07 BL	DX Hutch/Chest Vertical Trim, BL	2
19	Z-7221HC-07 RD	DX Hutch/Chest Vertical Trim, RD	2
19	Z-7221HC-07 BK	DX Hutch/Chest Vertical Trim, BK	2
20	ZDPDX955-BL	DX41 Chest/hutch lid pull, Blue	1
20	ZDPDX955-RD	DX41 Chest/hutch lid pull, Red	1
20	ZDPDX955-BK	DX41 Chest/hutch lid pull, Black	1
20A	ZM4NTSR	M4 Serrated nut for DX drawer pull handle/chest lid handle	8
21	ACPTHBK	Power Tool Holder, Black	1
21	ACPTHBL	Power Tool Holder, Blue	1
21	ACPTRGN	Power Tool Holder, Green	1
21	ACPTHMB	Power Tool Holder, Matte Black	1
21	ACPTHOR	Power Tool Holder, Orange	1
23	Z-LGL	Extreme Tools Logo	1
24	Z-BRJHOOKDXHC	J hook bracket for mounting DX HC side panel to DXRC,	2
25	ZM8SCHX-16	M8X16 Hex Bolts	2
		*NOT SHOWN ON DRAWING	

HUTCH ASSEMBLY INSTRUCTIONS

STEP 1: Remove End Caps

- a. IMPORTANT! Engage the brakes on the casters of the roller cabinet!
- b. Remove plastic end caps from the top of the trim on the roller cabinet.
- c. Set aside to re-install later.

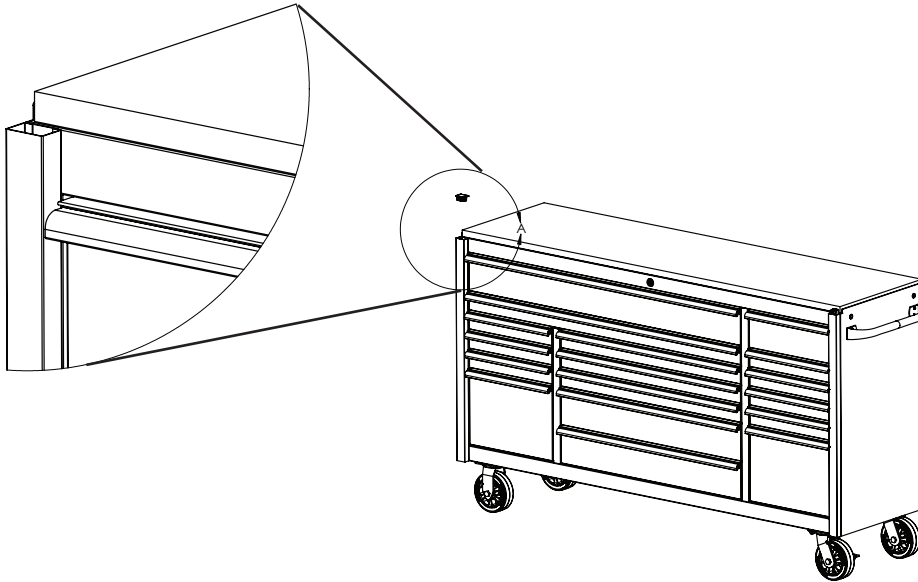

STEP 2: Remove Trim from Side Panels

- a. Detach the covers from the vertical trim of the hutch side panel assemblies.
- b. Set aside to re-attach after hutch is assembled.

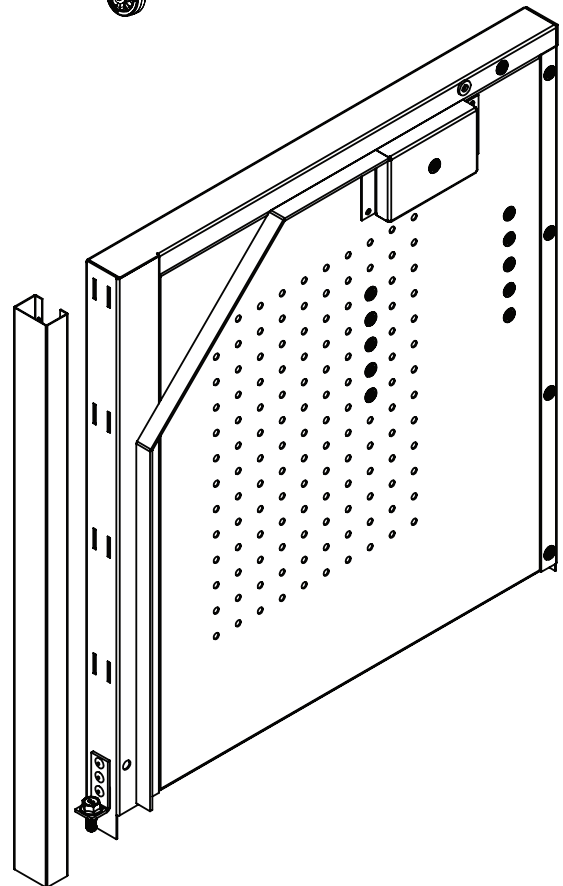

STEP 3: Install Left & Right Side Panel Assembly

- a. Insert the "J" end of the J-Connector into the rectangular opening at the top of the trim of the roller cabinet where the end cap was removed. The "J" end of the connector should be facing the body of the tool box. The top end with the threaded insert should be oriented to the front of the trim.
- b. Insert M8 Hex Bolt through top of the "L" Bracket and screw into the top of the threaded insert of the J-Connector.
- c. Attach the side mounting bracket through the opening on side panel. Use Flat Washer and M8 Bolt to secure to the roller cabinet.
- d. Repeat Steps a, b, c for the other side panel.

If attaching side locker,
remove side mounting
bracket

Side mounting
bracket secures
side panel to roller
cabinet

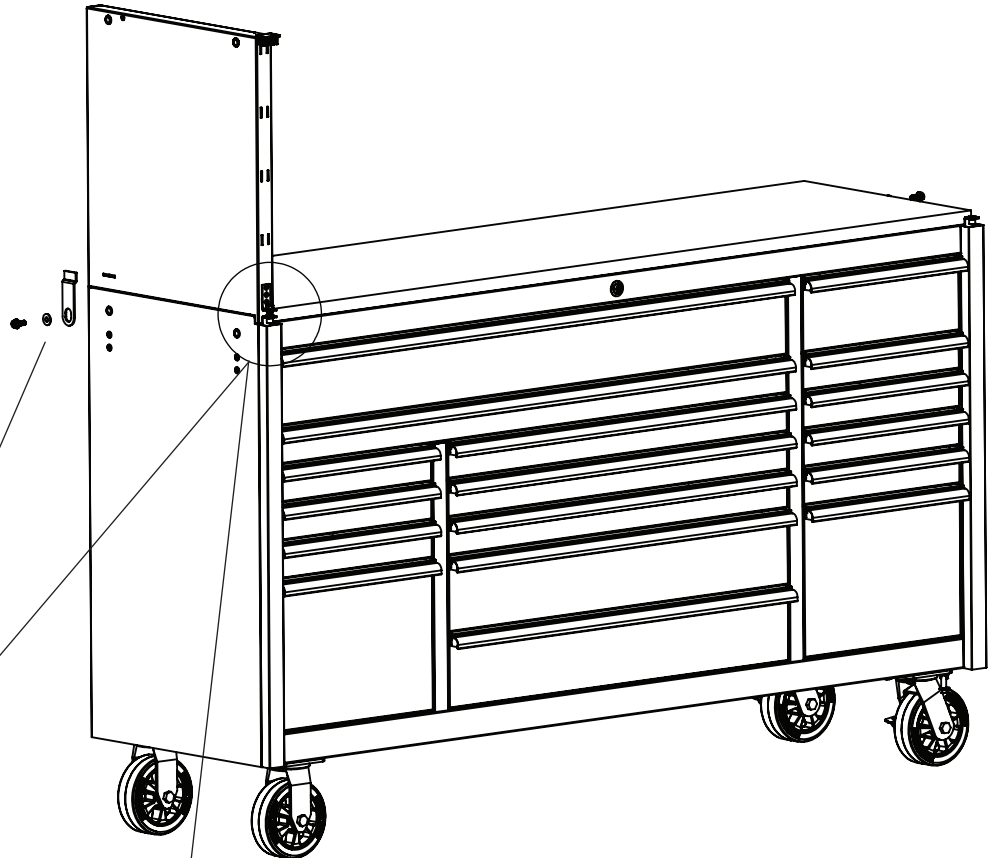

Insert M8 Hex Bolt through
"L" bracket hole and
into threaded insert of
J-Connector.

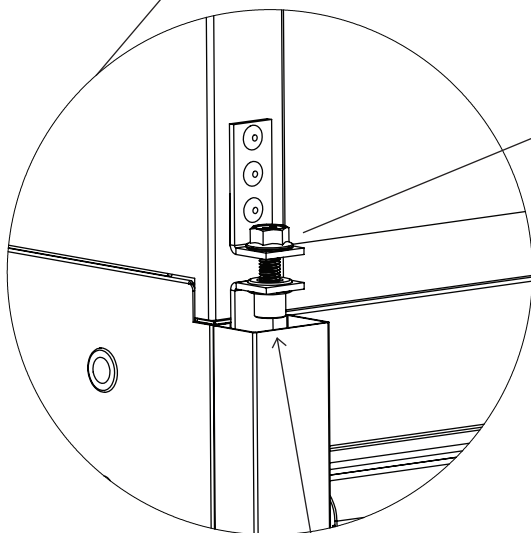

J-Connector installation into trim
piece on roller cabinet

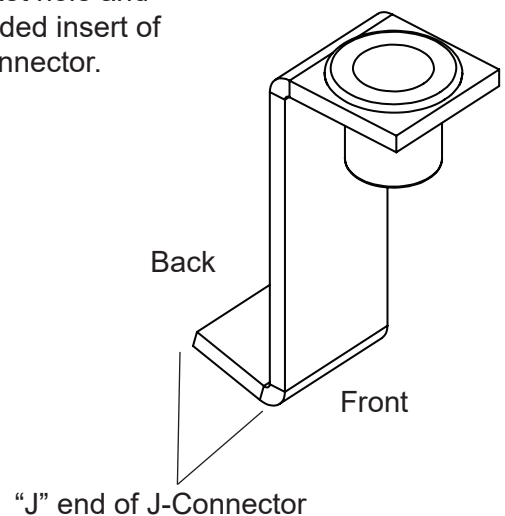

"J" end of J-Connector

STEP 4: Install Adjustable Shelf

- a. Determine the desired height for the Adjustable Shelf. Pre-thread (2) screws (#11) about halfway in on left-hand and right-hand sides.
- b. Locate the (2) cutouts on each side of the shelf. Line up the open slots with the (4) threaded screws that were installed in Step 5d. Lay down shelf so that (4) open slots fit on top of the (4) screws.
- c. Loosely tighten (4) screws.

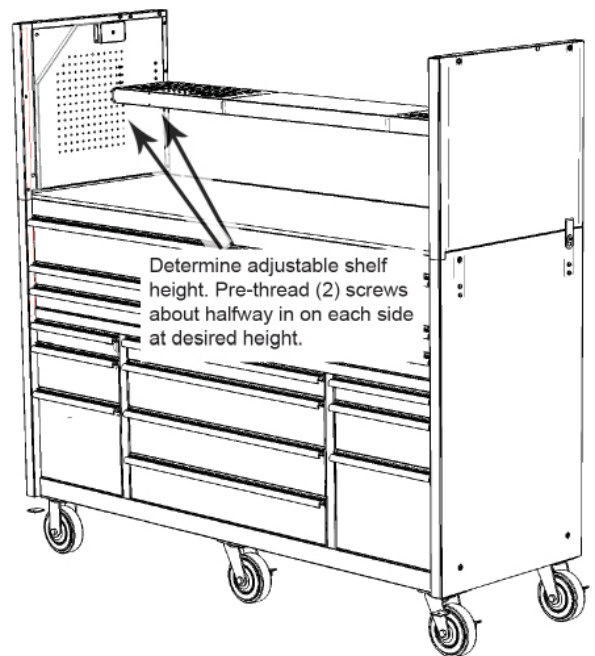
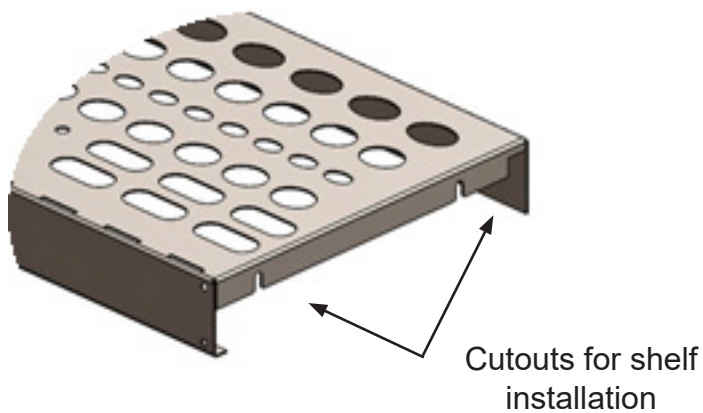
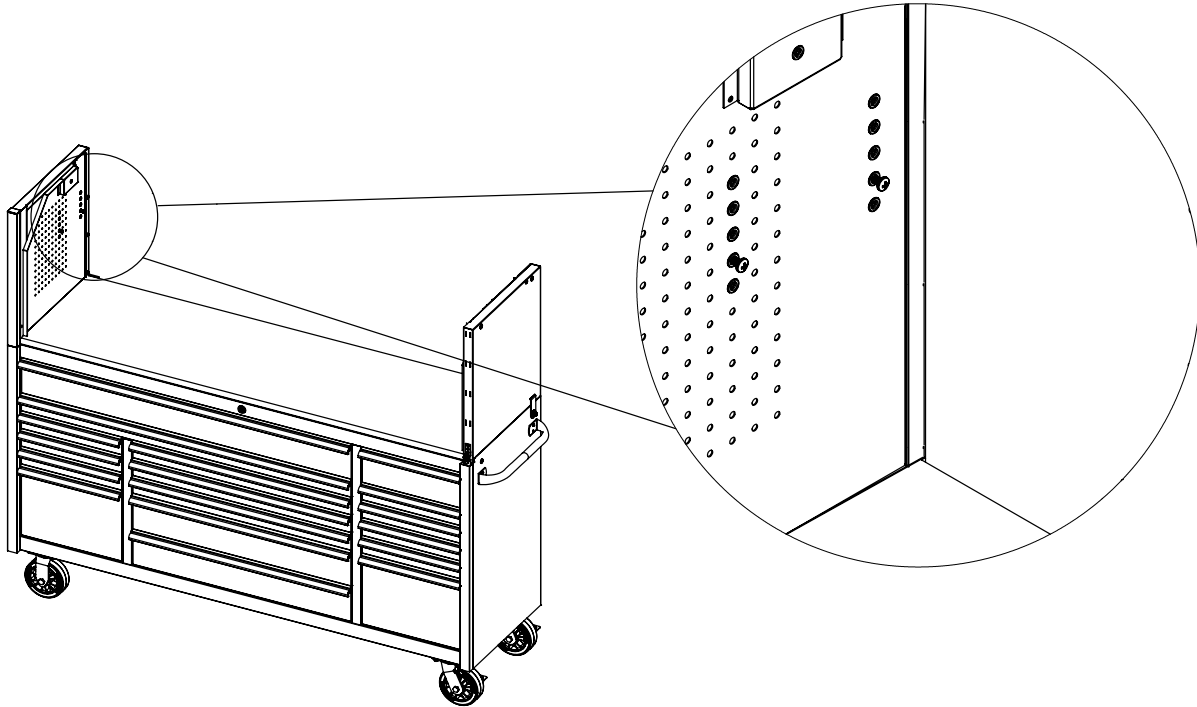

STEP 5: Install Back Panel

- a. Pull MDF board/Stainless Steel Top forward approximately 1/8" from Back Raised Edge (aka: Fence Rail.)
- b. Lift Back Panel into place behind the two side panels. (BACK PANEL is HEAVY and requires 2 people to place!) Slide the bottom edge of the Back Panel between the MDF/Stainless Steel Top and rear fence rail of roller cabinet. Flange on left and right sides of back panel should be resting against the inside back edges of both side panels.

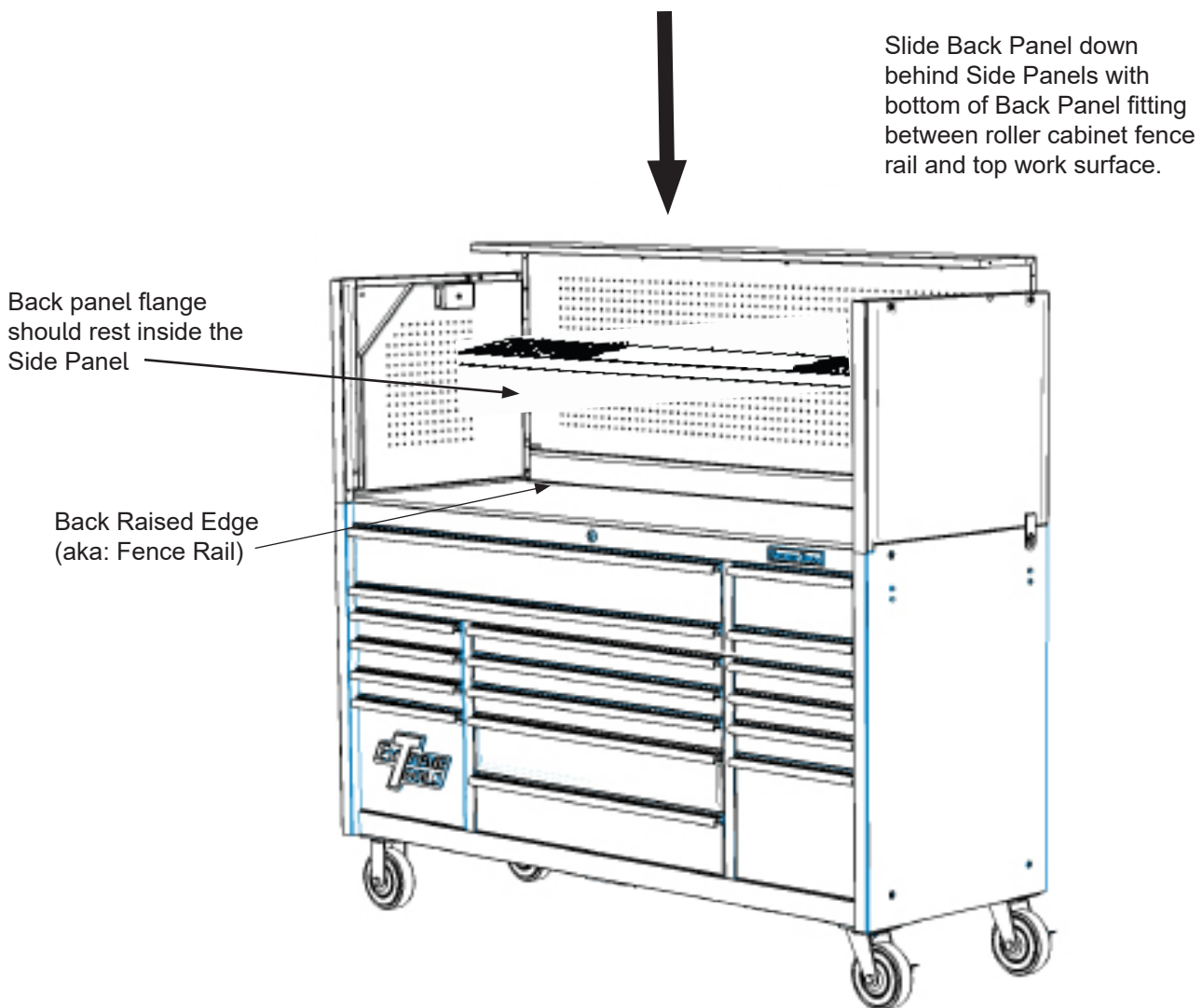

STEP 6: Secure Shelf to Back Panel

- a. Locate (2) threaded inserts on the back of the shelf. From the back of the Back Panel, insert (2) screws through the back of the pegboard and through the threaded inserts of the shelf and tighten.
- b. Tighten the Screws on both side panels to secure the shelf in place.

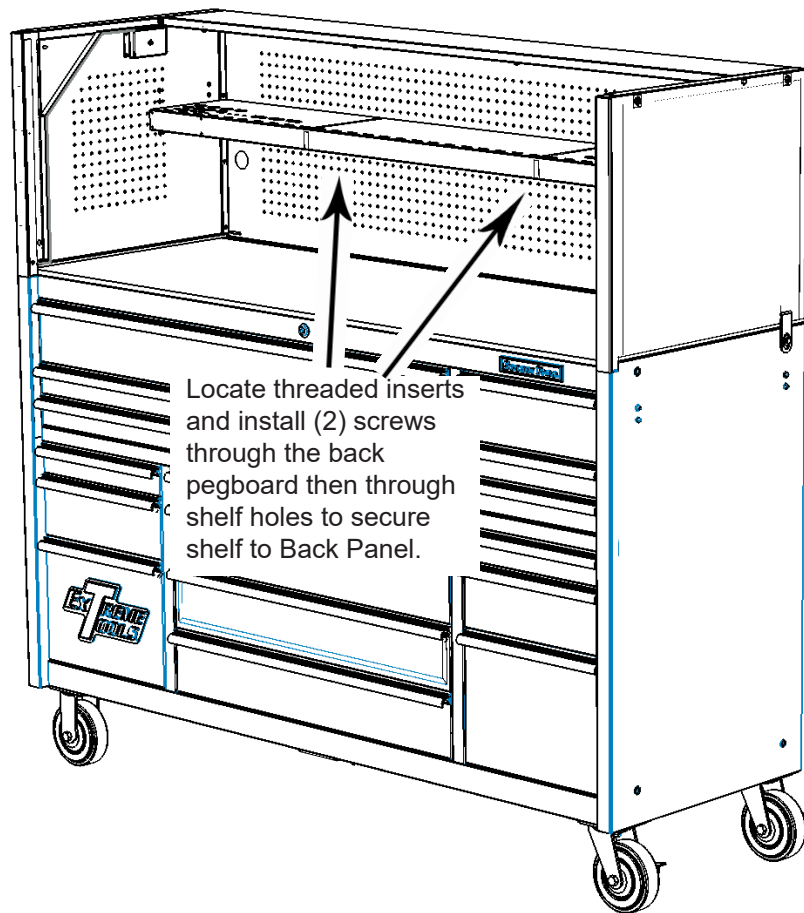

STEP 7: Attach Gas Struts to Lid

- a. Lay the lid down on packaging material so that the front of the lid is face down. Use a soft surface or packaging material under the lid so that it does not get scratched or damaged.
- b. Locate the middle hinge of the front/top lid assembly.
- c. Using a Phillips screw driver, remove 3 screw holding hinge in place.
- d. Disengage the other hinges that hold the front lid panel to the hood assembly by sliding the front lid panel to the side. Remove front lid panel and lay down with the inner stiffener panel facing up onto a soft surface to prevent scratching.

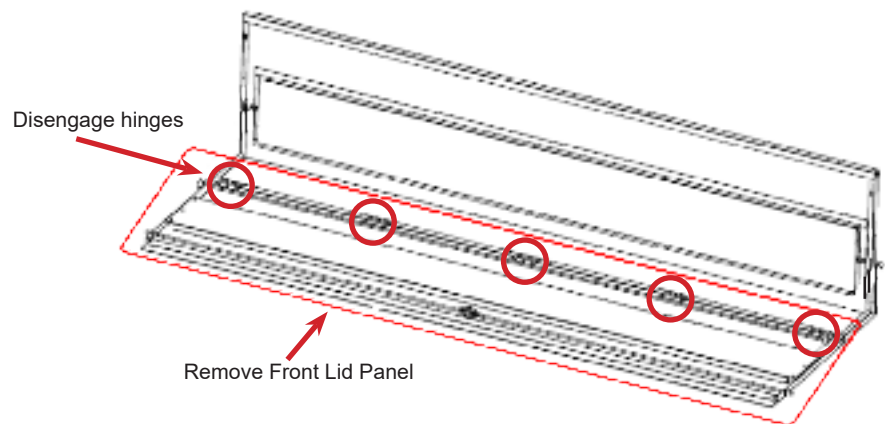

- e. Install the piston side of the gas strut into ball joint which is located at the end of the stiffener of the top lid panel. Repeat procedure for the other side.

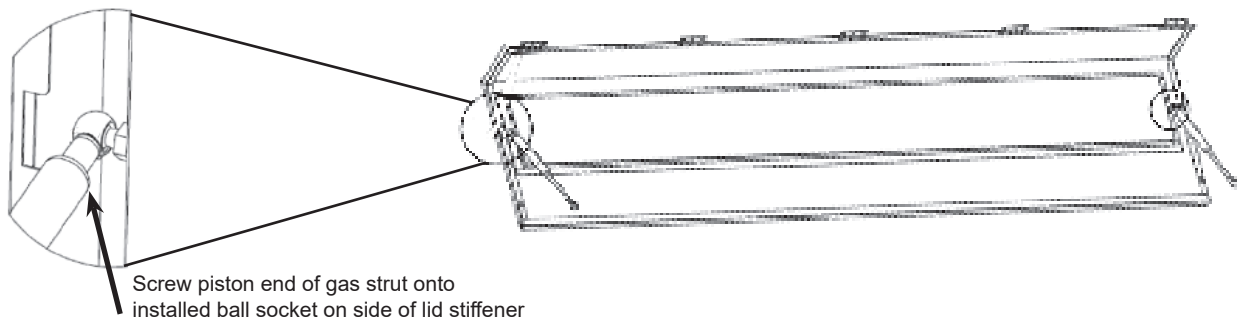

- f. Install M6x35mm socket head screw (ZM6SCSH-35) onto both side panels. Make sure the screw head is flush with the inner side panel.

STEP 8: Secure Lid to Body of Hutch - may require assistance of another adult

- a. Position the top front panel so that it rests on top of the side and back panels and holes on lid and side panels are aligned as shown below.
- b. Use the Allen wrench (supplied with the parts) to drive the pre-threaded M6x35mm Sock Head Screw (#15) into the round opening on the side of the lid. Repeat on the other side.
- c. Insert one plastic hole plug (#17) in each of the socket head screw openings.

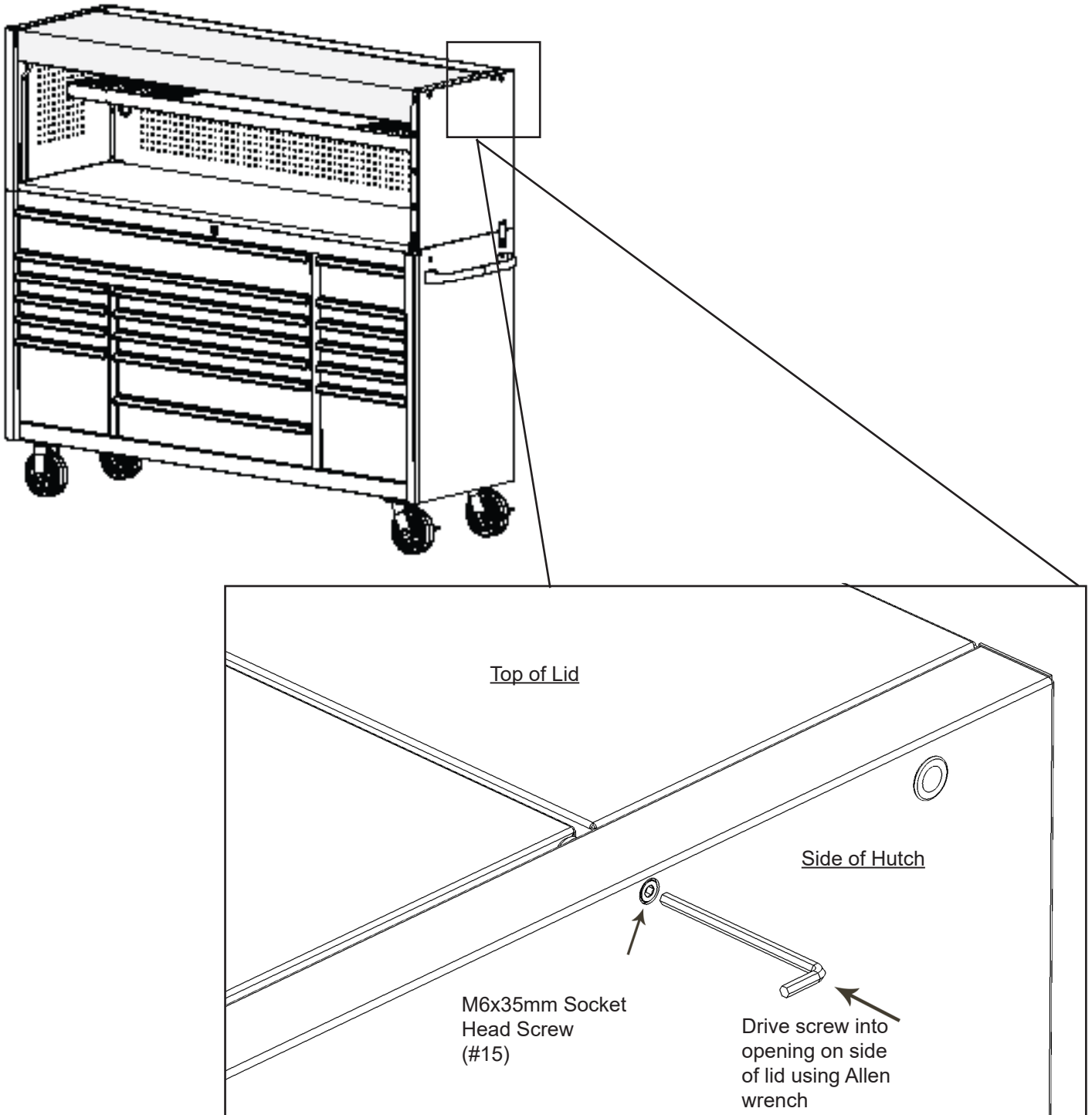

STEP 9: Secure Gas Strut to Side of Hutch

- a. Lift top/front panel so that the unattached ball joint on the gas strut is lined up with the rivet nut hole on the side panel.
- b. Hand-tighten the male stud into the rivet nut opening. Strut must be fully engaged with the ball stud. Open and close the lid to confirm alignment. You should feel some tension when engaging the strut.
- c. Securely tighten socket in place using M12 Box wrench.
- d. Repeat for the gas strut (#6) on the other side.
- e. Test lid function by opening and closing several times.
- e. **Confirm that gas struts are holding lid securely in open position before proceeding.**

Align ball joint with rivet nut hole on side panel. Secure the male end of the piston into the opening on the side of the hutch. Secure with M12 box wrench.

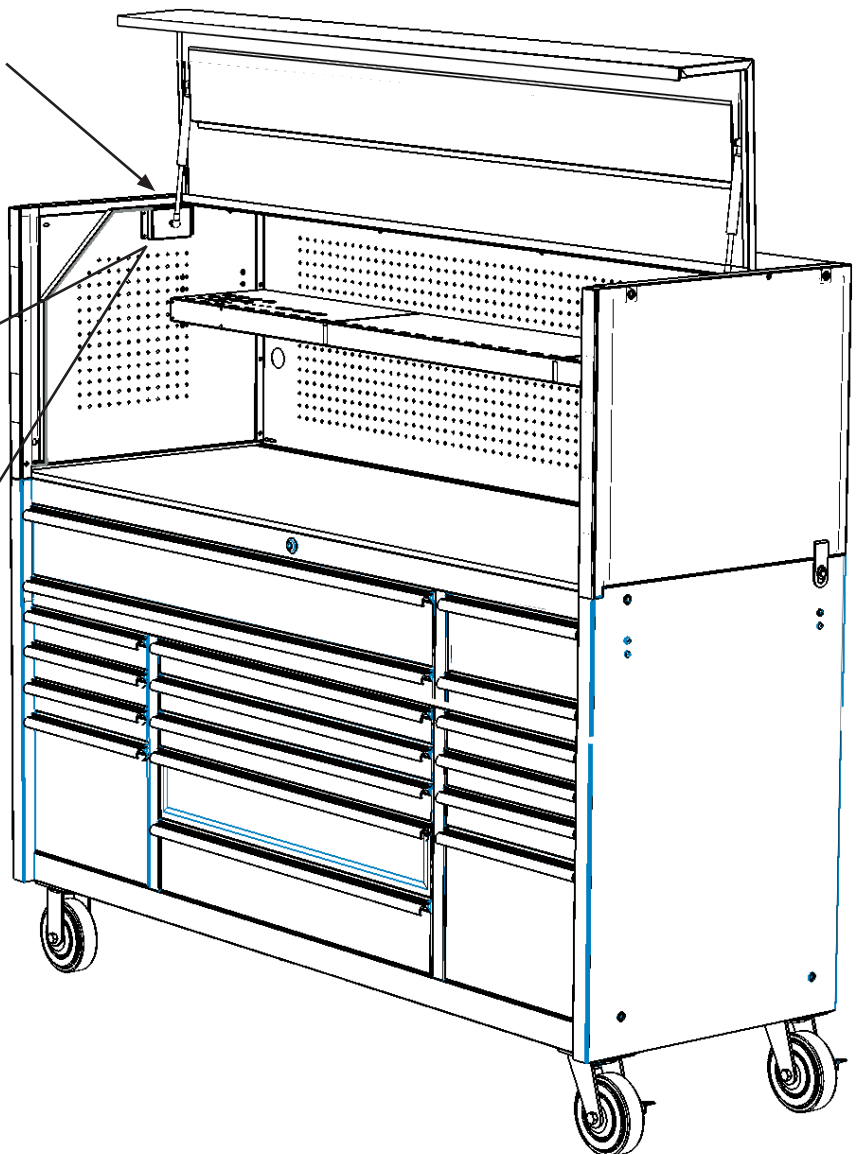
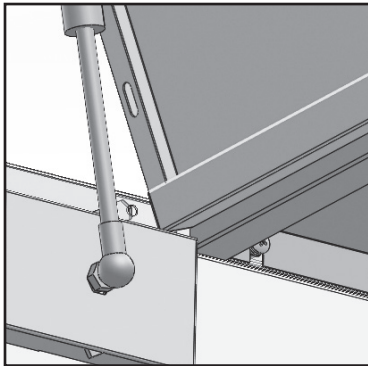

STEP 10: Re-Attach Front Panel to Lid

- a. Lift front panel into place to re-attach to lid. Align the hinges on the top panel with the hinges on the lid and slide into place. Smooth side of lid should face out - panel stiffener should be on the inside.
- b. Replace and secure the front panel to lid with 3 Phillip screws that were removed in Step 8.
- c. Securely tighten the screws.
- d. Open and close the lid several times to confirm that lid is secure and aligned.

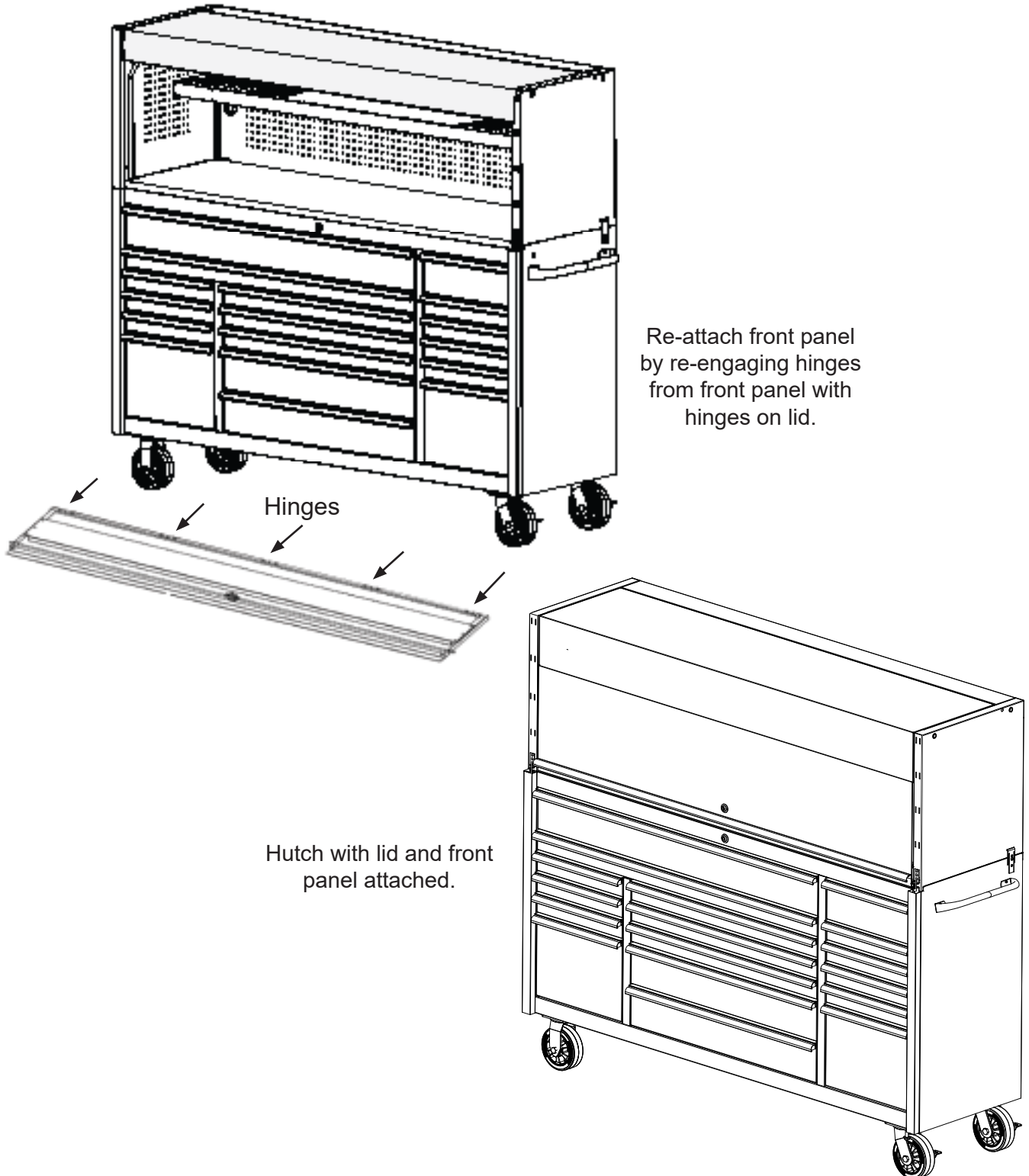

Step 11: Final Assembly

- a. Re-attach the Vertical Trim Covers to the front of the Hutch Side Panels.
- b. Insert the End Caps into the openings at the top of the Vertical Trim Covers.
- c. Use the supplied hardware to attach the Power Strip on either the right or left side of the face of the adjustable shelf.

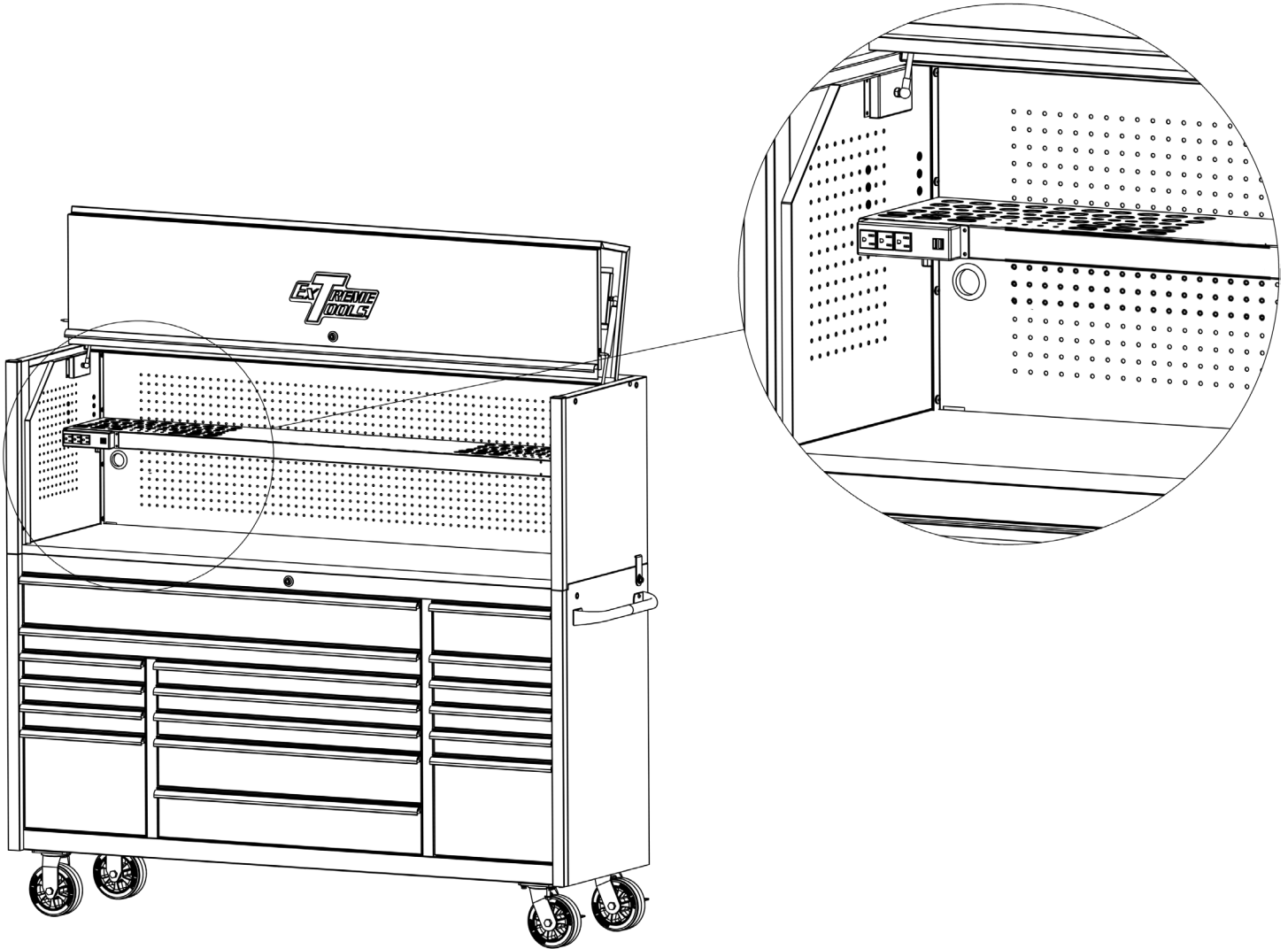

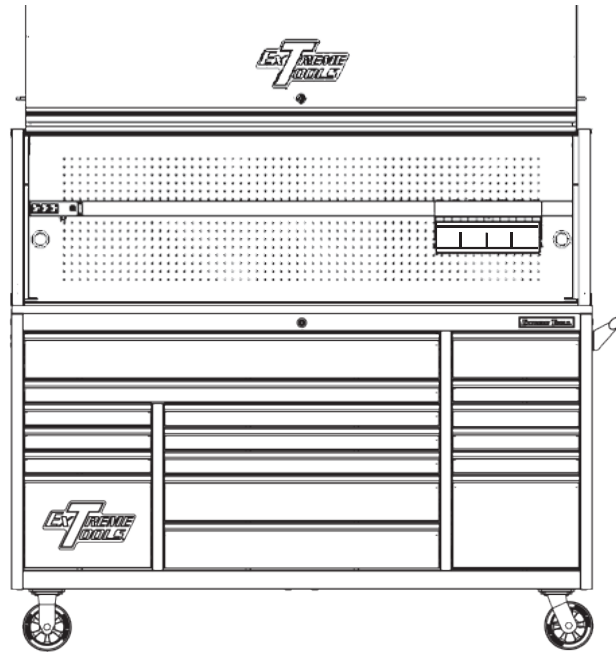

DX Series DX722101HC or DX7201HC 72 in. Extreme Power Workstation® Hutch
with Power Tool Rack Accessory
*shown assembled on
DX722117RC or DX7217RC 72 in. 17 Drawer Roller Cabinet (sold separately)*

DX Series 41 in. & 72 in. Extreme Power Workstation® Hutches
shown assembled on Roller Cabinets (sold separately)

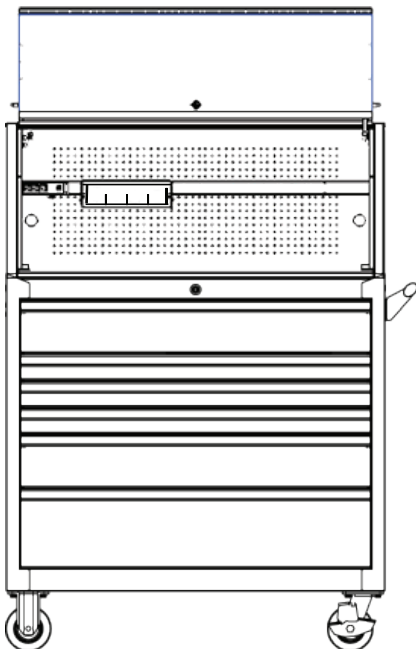

DX Series 41 in. 6-Drawer Roller Cabinet
DX412506RC or DX4106RC

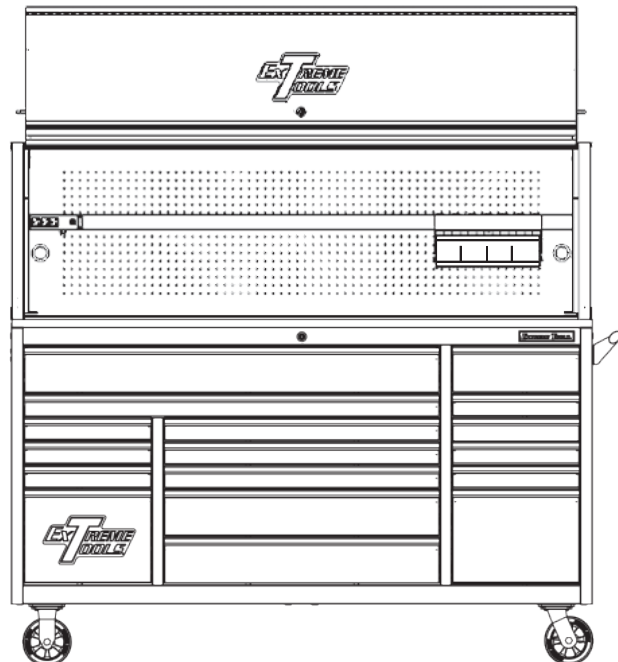

DX Series 72 in. 17-Drawer Roller Cabinet
DX722117RC or DX7217RC