

PRODUCT MANUAL

LP GAS GRILL

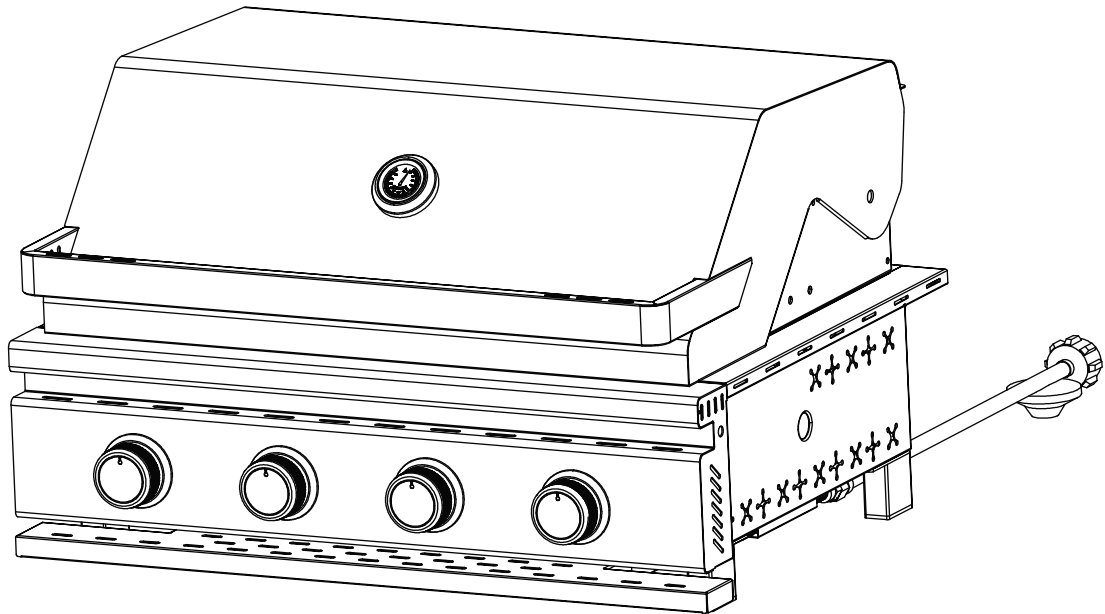

MODEL NO.: JQ-4G

The picture is for reference only and the actual product shall prevail.



Scan to watch the
product videos



TEL: 818-468-1498



Web: www.rwflame.com



Email: support@rwflame.com

TABLE OF CONTENTS

SAFETY INFORMATION	1
PACKAGE CONTENTS	3
PREPARATION	4
ASSEMBLY INSTRUCTIONS	4
OPERATION INSTRUCTIONS	12
CARE AND MAINTENANCE	17
TROUBLESHOOTING	20

Assembler/Installer: This manual contains important information that is necessary for the proper assembly and safe use of this appliance. Read and follow all warnings and instructions before assembling and using this appliance. **Leave these instructions with the consumer.**

Consumer/User: Follow all warnings and instructions when using this appliance.
Retain these instructions for future reference.

DANGER

If you smell gas:

1. Cut off the gas to the appliance.
2. Extinguish any open flame.
3. Open the lid.
4. If the odor continues, keep away from the appliance and immediately call your local fire department.

WARNING

1. Do not store or use gasoline, vapors, or other flammable fluids close to this or any other appliance.
2. An LP cylinder not connected for use shall not be stored in the vicinity of this or any other appliance.
3. Do not leave a lit grill unattended. Keep children and pets away from the grill at all times.



SAFETY INFORMATION

Thank you for purchasing this product! If you have any question about the product such as missing parts, damaged products, product assembling, operation, etc., please contact us via our customer service phone: 818-468-1498.

DANGER

- Do not use in an explosive atmosphere. Keep grill area clear and free from combustible materials, gasoline and other flammable vapors and liquids.

CAUTION

- Never use charcoal or lighter fluid with the grill.
- Do not use gasoline, kerosene or alcohol for lighting.
- The LP gas cylinder used with this appliance must be:
 - (a) Constructed and marked in accordance with the Specifications for LP-Gas Cylinders of the U.S. Department of Transportation (D.O.T.) or the National Standard of Canada, CAN/CSA-B339, Cylinders, Spheres and Tubes for Transportation of Dangerous Goods; and Commission, as applicable; and
 - (b) Provided with a listed overfilling prevention device.
 - (c) Provided with a cylinder connection device compatible with the connector for outdoor cooking appliances. This grill is not intended to be used in or installed on recreational vehicles and/or boats.
 - (d) The marked cylinder water capacity or LPG capacity (in pounds) as stated by the cylinder manufacturer(s).
- Never keep a filled container in a hot car or car trunk. Heat will cause the gas pressure to increase, may open the relief valve and leak the gas.
- Always open grill lid slowly and carefully as heat and steam trapped within the grill can hurt you severely.



SAFETY INFORMATION

⚠ WARNING

Do not place the grill under overhead combustible construction or awnings.

The minimum clearance between the side/back of the unit and any other construction is 40 inches (1016.0 mm).

NOTE: The installation must conform with local codes or, in the absence of local codes, with either the National Fuel Gas Code, ANSI Z223.1/NFPA54, Natural Gas and Propane Installation Code, CSAB149.1, or Propane Storage and Handling Code, B149.2.

⚠ CAUTION

- Do not store or use gasoline or other flammable liquids or vapors close to this or any other appliance.
- An LP cylinder not connected for use shall not be stored close to this or any other appliance.
- This grill is for using with propane gas only.
- Never attempt to attach this grill to the self-contained propane system of a boat, camper trailer, motor home or house.
- Do not attempt to move the grill while it is lit or when it is hot.
- Do not use the grill unless it is completely assembled and all parts are securely fastened and tightened.
- Keep all combustible items and surfaces at least 40 inches (101.6 cm) away from the grill at all times.
- Do not touch metal parts of grill until it has completely cooled (about 45 minutes) to avoid burns, unless you are wearing protective gear (pot holders, gloves, BBQ mittens, etc.).
- Do not alter this grill in any manner.
- Clean and inspect the hose before each use. If there is obvious abrasion, wear, cuts, or leaks, the hose must be replaced prior to operating the appliance. The replacement hose assembly shall be that specified by the manufacturer.
- Move gas hoses as far away as possible from the hot surfaces and dripping hot grease.
- Keep the grill's valve compartment, burners and circulating air passages clean. Inspect the grill before each use. Do not obstruct the flow of gas or ventilation air.
- The use of alcohol, prescription or non-prescription drugs may influence the operator's ability to properly assemble or safely operate the grill.
- **Do not leave a lit grill unattended. Keep children and pets away from the grill at all times.**
- The grill should be placed on a flat and level surface.
- Do not use the grill in strong winds.

PACKAGE CONTENTS

NOTE: Please read the picture and product list of the package contents carefully before assembly.
NOTE: This product is available in two different appearances. The one with viewing window is easy for customers to check the food condition.

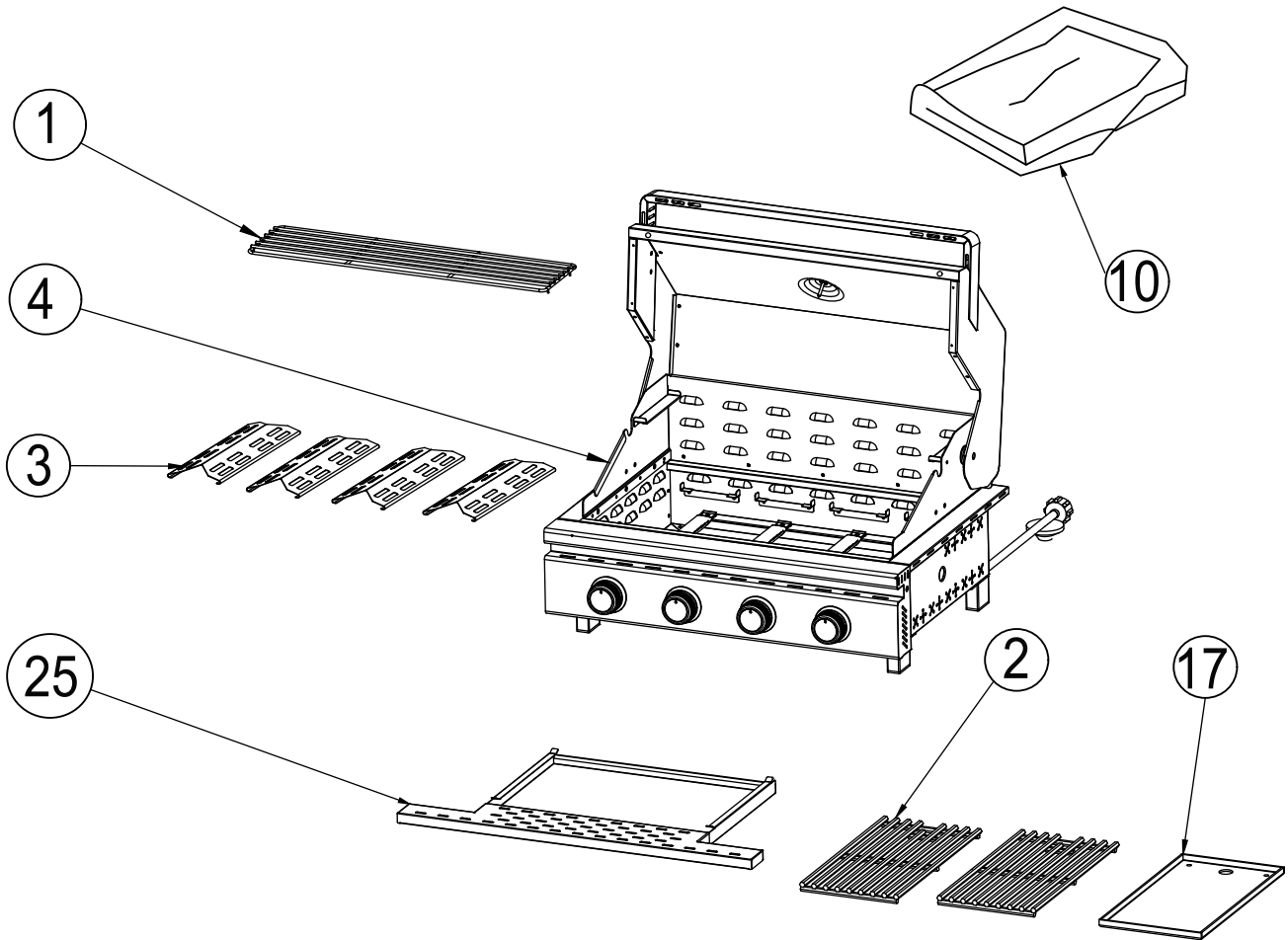

No.	Description	Quantity	No.	Description	Quantity
1	Warming rack	1	10	Rain Cover	1
2	Grill	2	17	Frying Pan	1
3	Heating Plate	4	25	Oil Drip Pan	1
4	Grill Body	1			

PREPARATION

Before start assembling product, make sure all parts are present. Compare parts and hardwares with the list on the package contents page. If any part is missing or damaged, do not attempt to assemble the product. Contact customer service for replacement parts.

Estimated Assembly Time: 5 minutes with 1 person.

Tools Required for Assembly and Leak Testing: Phillips screwdriver, Spray bottle.

NOTE: Common tools used for leak testing are not included in the accessories.



CAUTION

Some parts may contain sharp edges. Wear protective gloves if necessary. Read and follow all safety statements, warnings, assembly instructions and use and care instructions before attempting to assemble and use.

ASSEMBLY INSTRUCTIONS

A. Installation of Heating Plate and Warming Rack

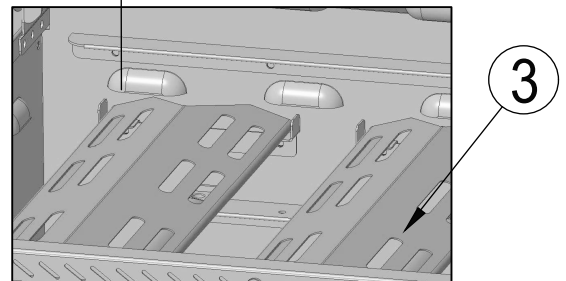
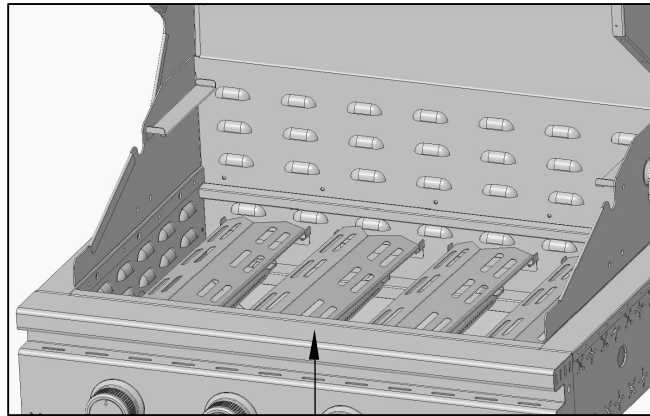
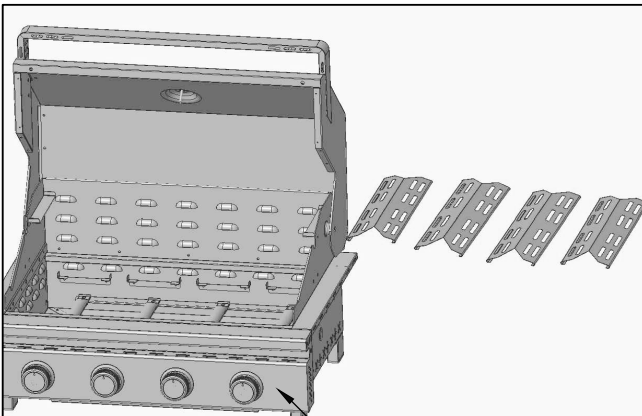

Place four pieces of grill heating plates (3) inside the grill body (4).

ASSEMBLY INSTRUCTIONS

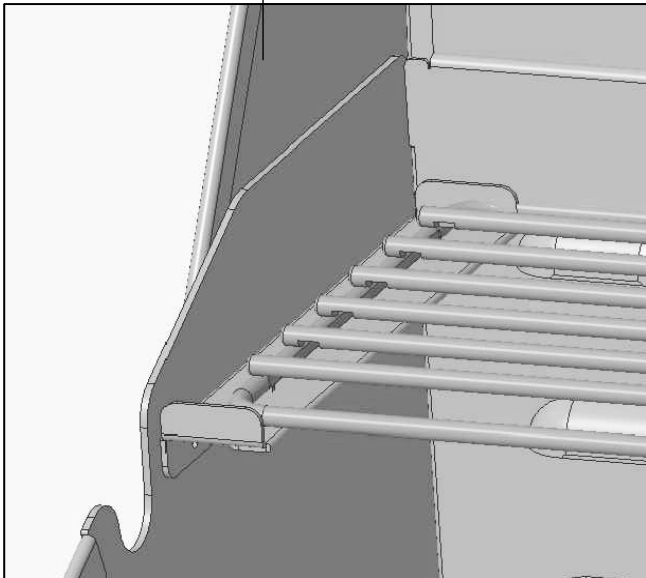
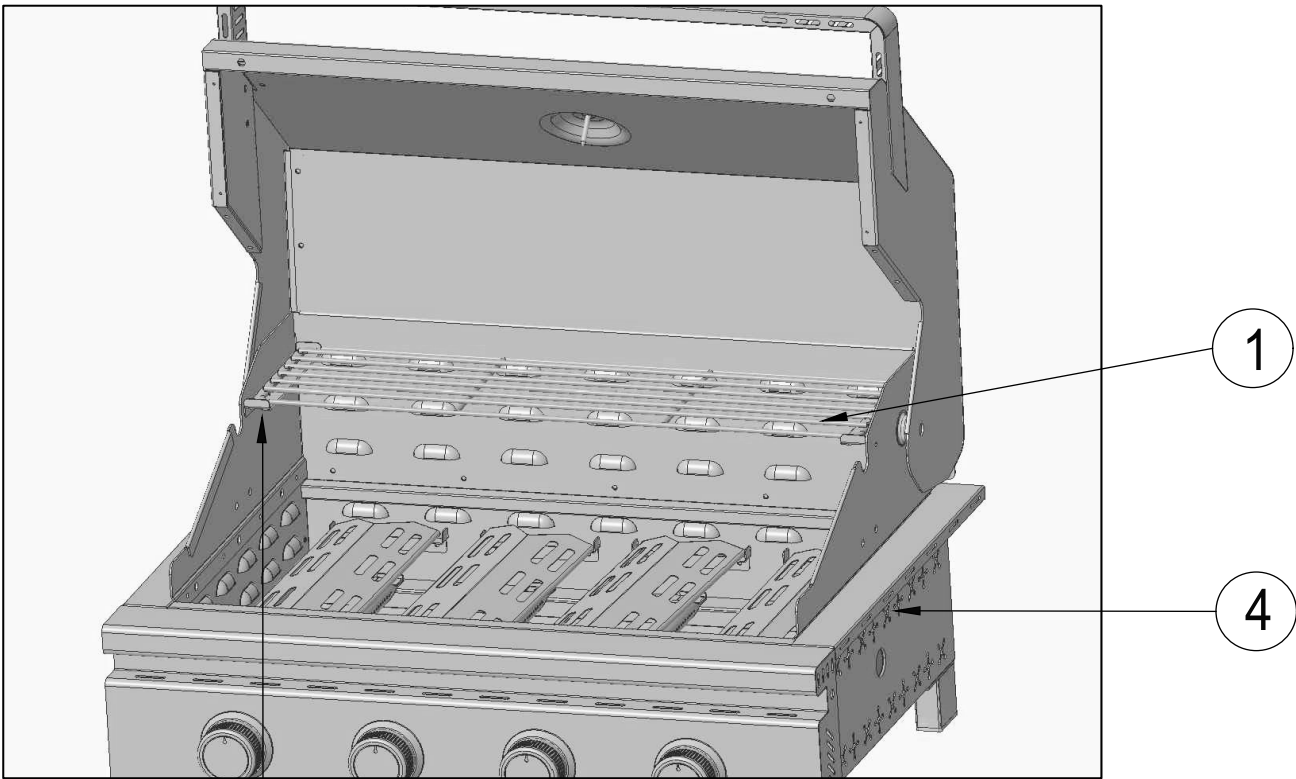

Place the warming rack (1) in place.

ASSEMBLY INSTRUCTIONS

B. Installation of Grills and Frying Pan

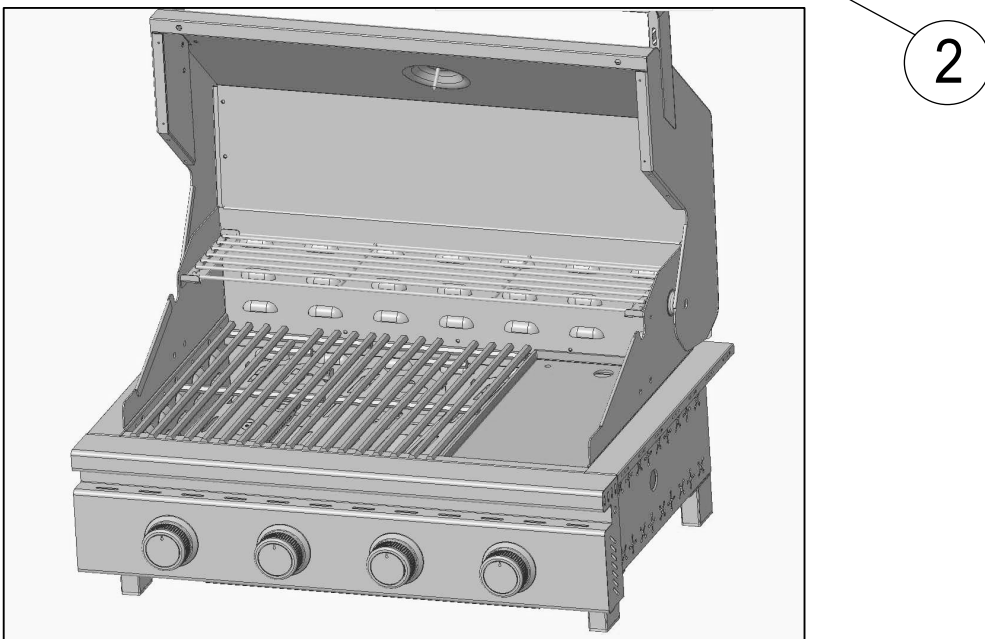
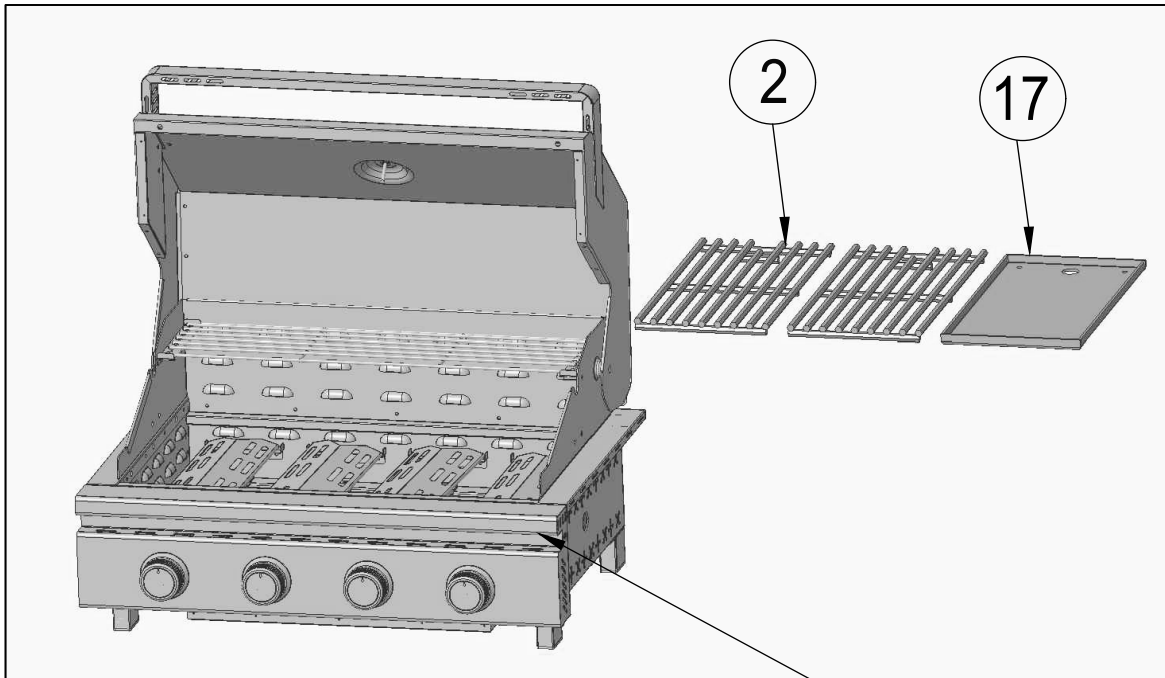

Place the two grills (2) and frying pan (17) inside of the grill body.

ASSEMBLY INSTRUCTIONS

C.Installation of Oil Drip Pan

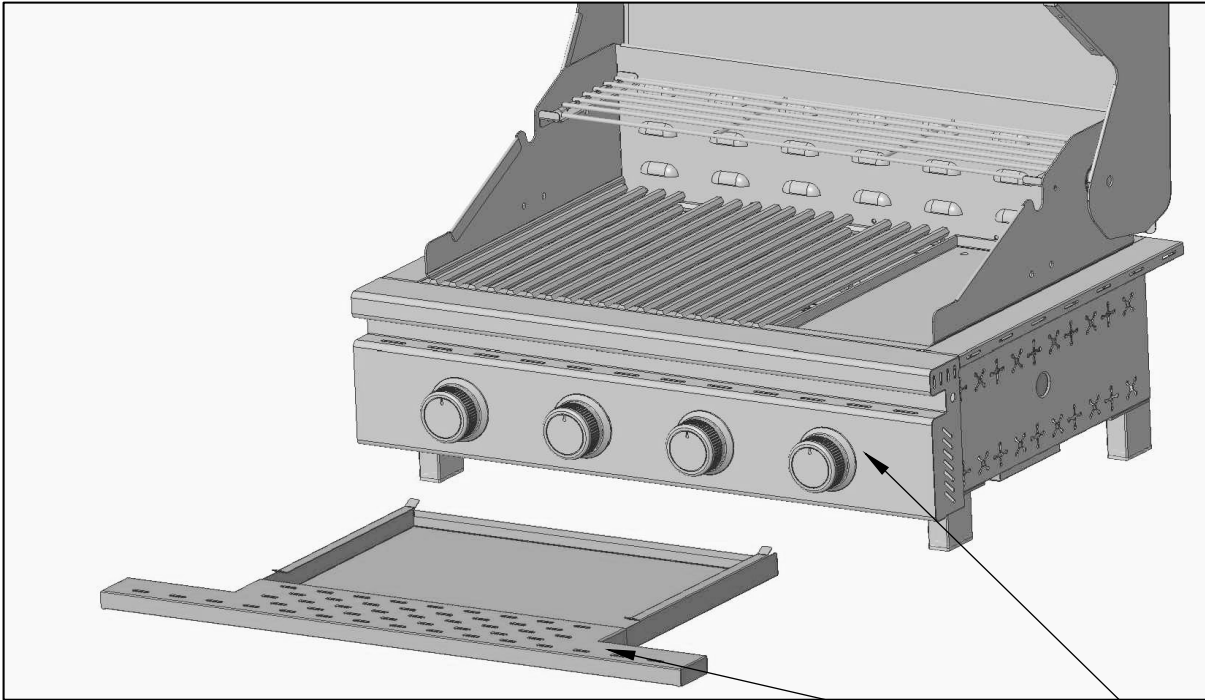

25

4

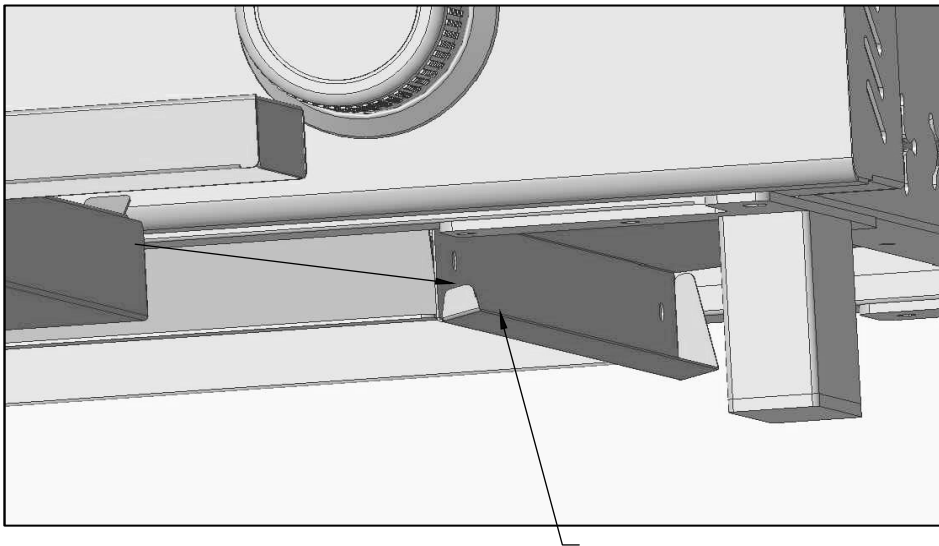

Note: The oil drip pan can only be fixed by inserting it into the guide rail

Place the oil drip pan (25) under the grill body (4).

ASSEMBLY INSTRUCTIONS

D. Installation Completed

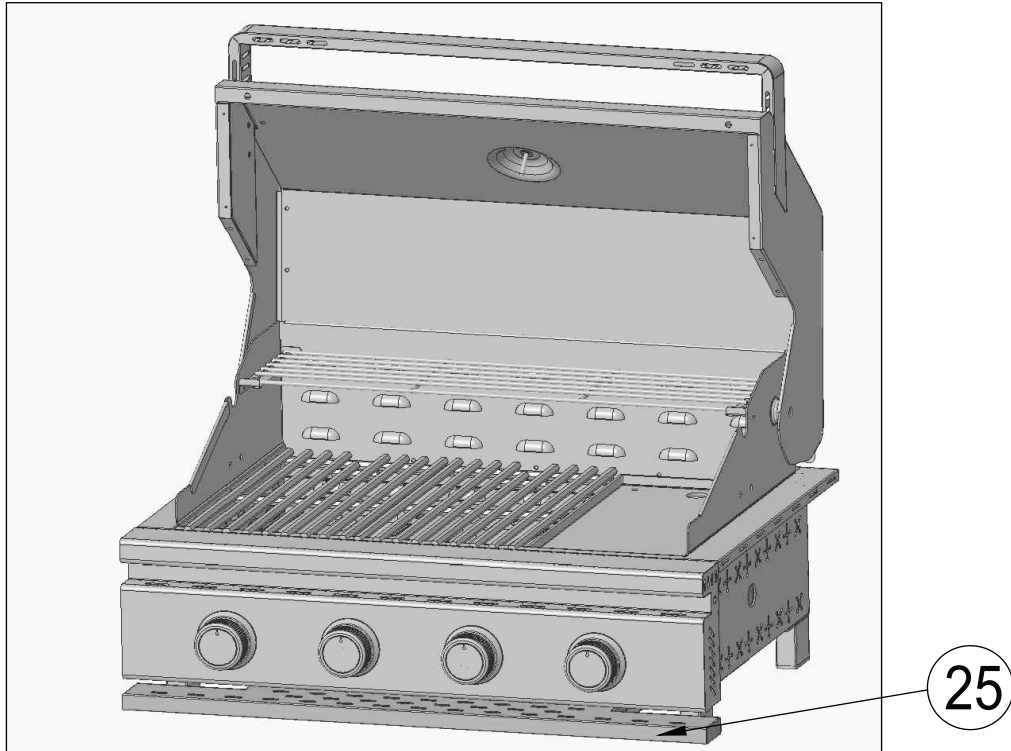

Embedded Installation Instructions(For reference only)。

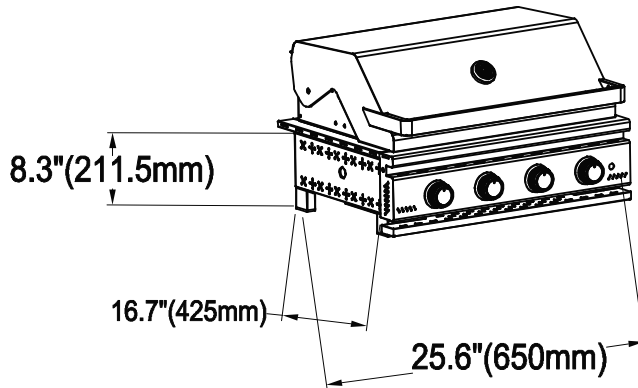

A hole needs to be made in the pit here for air circulation

Hole for passing gas hose

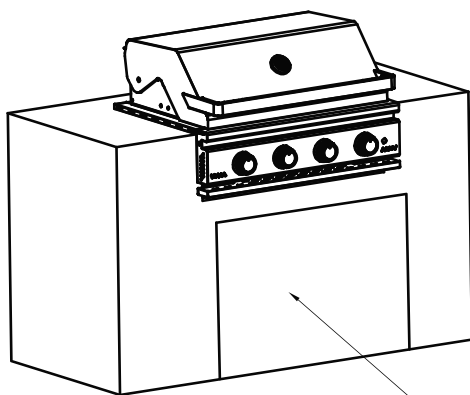
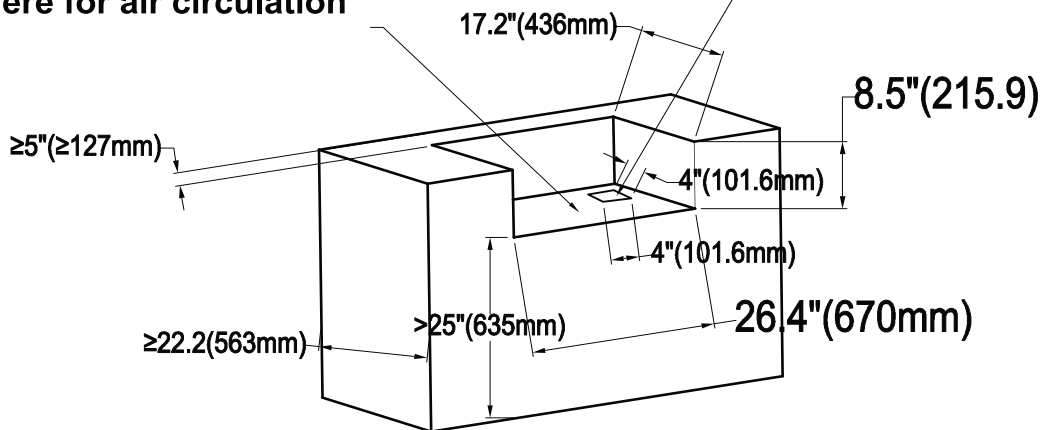

Gas cylinder placement area

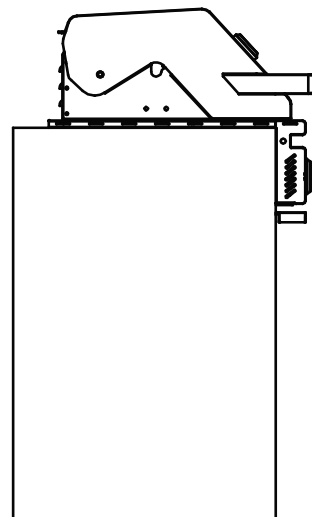

Control panel

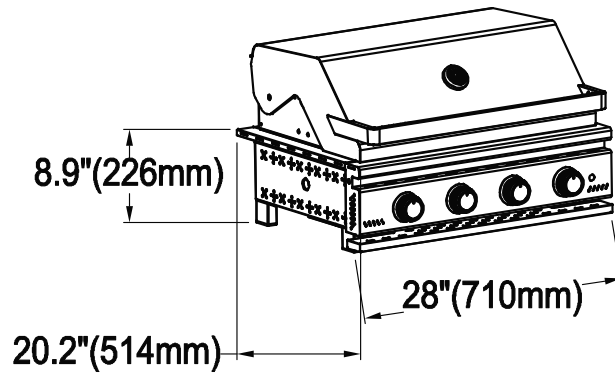

A hole needs to be made in the pit here for air circulation
Hole for passing gas hose

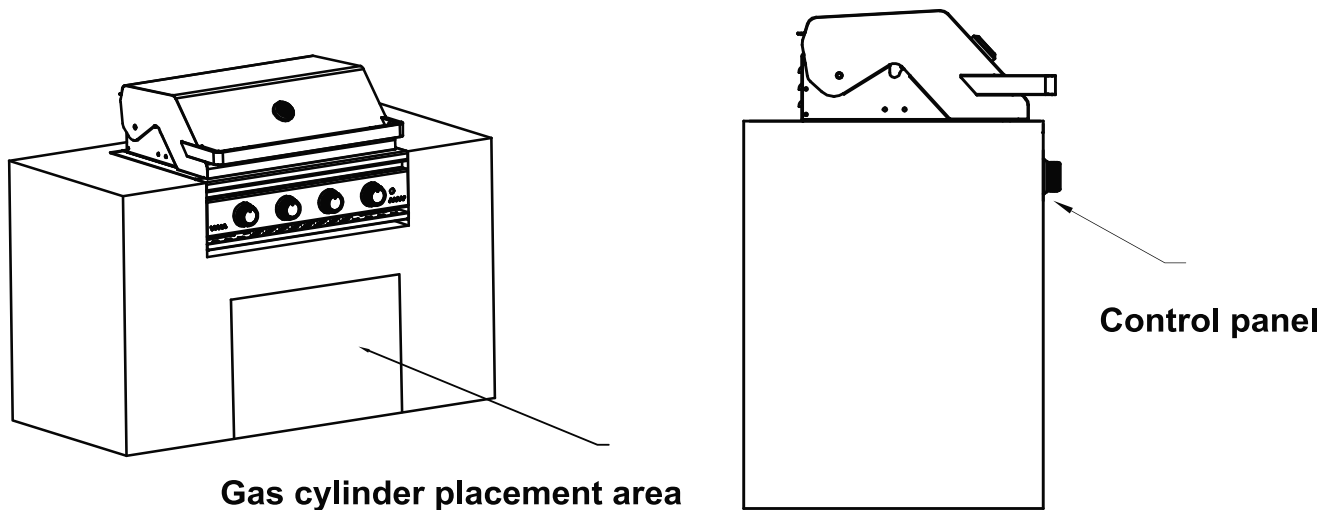
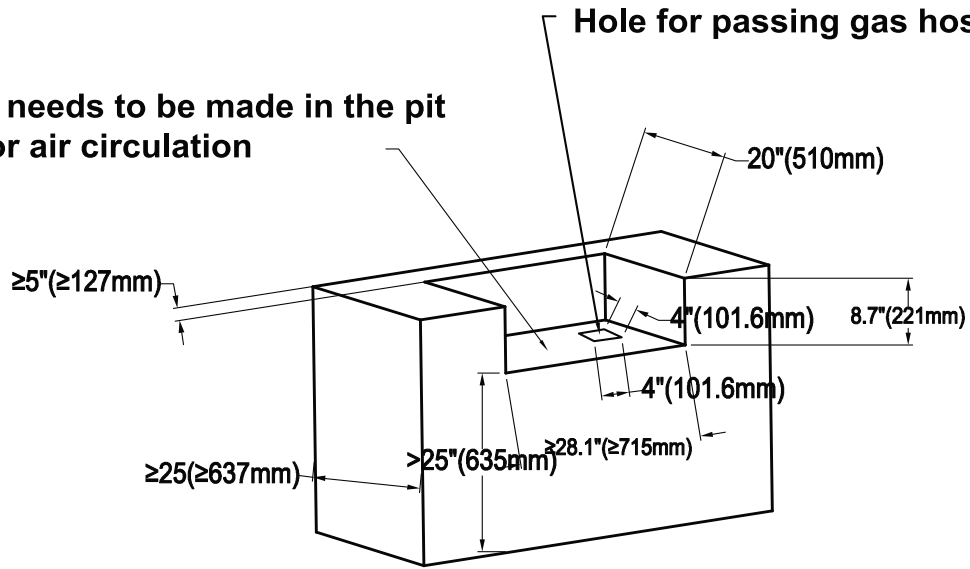

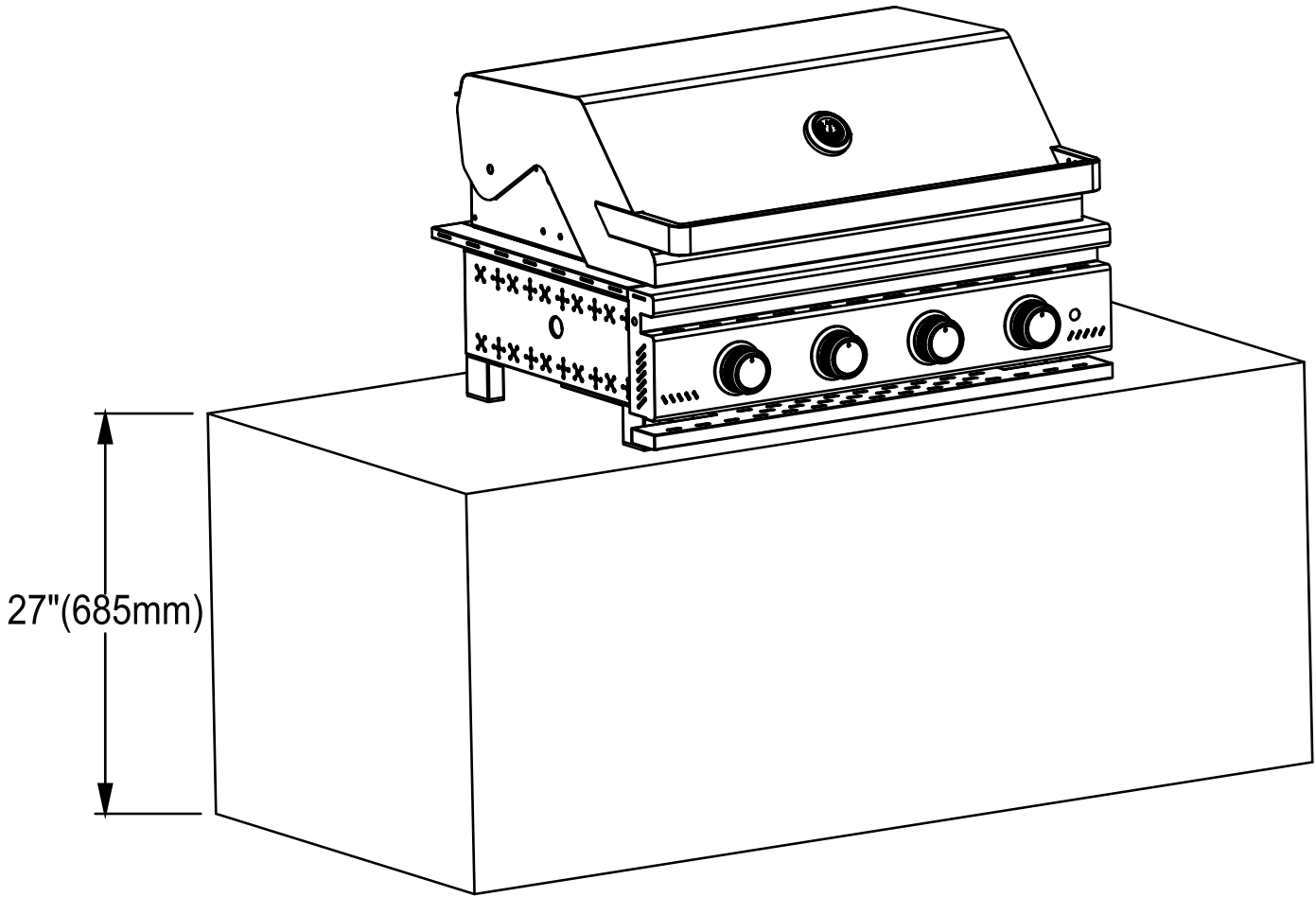

OPERATION INSTRUCTIONS

CHECKING FOR LEAKS

If you use a LP gas tank, please check for leaks:

After all connections are made, check all connections and fittings on the threaded valve of the LP gas tank, gas hose and regulator valve for leaks with a water and soap solution.

To prevent fire or explosion while testing for a leak:

- Always perform leak test prior to lighting the grill.
- Do not smoke while testing for a leak.
- Always perform leak tests outdoors in a well-ventilated area.
- Do not use any source of flame while testing for leaks.
- Do not use the grill until any and all leaks are corrected.
- If you are unable to correct a leak, disconnect the propane supply and call a gas appliance service dealer.

PERFORMING LEAK TEST

- Prepare leak test solution by 50/50 ratio of liquid dish soap and water. Total solution required is approximately 2 - 3 ounces (70 - 90 ml). Put leak test solution in a spray bottle.
- Ensure all control knobs are in the off position.
- Connect the gas hose to the gas supply.
- Open the cylinder valve of the LP gas tank.
- Spray leak test solution on all gas-carrying connections and fittings. Presence of bubbles at areas of applied test solution indicates a gas leak. If leaks are detected or you smell or hear gas, shut off the gas supply valve immediately and repair or replace the defective part. Do not use the grill until all leaks are corrected.

⚠ CAUTION

Only use the regulator valve and hose assembly provided! If a replacement is necessary, please call our customer service center. Do not use replacement parts that are not intended for this grill.

⚠ WARNING

ALL INSTRUCTIONS AND SAFEGUARDS ON THIS PAGE MUST BE FOLLOWED TO PREVENT FIRE, DAMAGE AND/OR INJURY.

OPERATION INSTRUCTIONS

CONNECTING LP GAS TANK

The propane gas supply cylinder to be used must be constructed and marked in accordance with the Specifications for LP Gas Cylinders of the U.S. Department of Transportation (D.O.T.) or the National Standard of Canada, CAN/CSA-B339, Cylinders, Spheres and Tubes for Transportation of Dangerous Goods; and Commission, as applicable; and provided with a listed overfilling prevention device.

Use only 20-pound cylinders (height: 18.11 inches, tank diameter: 9.84 inches, foot diameter: 8.03 inches) equipped with a cylinder connection device compatible with the connection for outdoor cooking appliances.

The cylinder must include a collar to protect the cylinder valve. The gas cylinder should not be dropped or handled roughly!

If the appliance is not in use, the gas cylinder must be disconnected. Storage of an appliance indoors is permissible ONLY if the cylinder is disconnected and removed from the appliance. Cylinders must be stored outdoors out of the reach of children and can not be stored in a building, garage or any other enclosed area. Your cylinder must never be stored where temperatures can reach over 125°F.

Place the dust cap on the cylinder valve outlet whenever the cylinder is not in use. Only install the type of dust cap on the cylinder valve outlet that is provided with the cylinder valve. Other types of caps or plugs may result in leakage of propane.

Before connection, be sure that there is no debris caught in the outlet of the gas cylinder, outlet of the regulator valve or in the outlet of the burner and burner ports. Connect regulator valve and hand-tighten firmly. Keep the propane cylinder valve closed and disconnect the propane cylinder from the regulator valve when the grill is not in use.

DO NOT obstruct the flow of combustion air and ventilation air to the grill. The propane cylinder must be arranged for vapor withdrawal and equipped with a listed overfilling prevention device. Please use the proper cylinder orientation to provide vapor withdrawal. NOTE: The cylinder must be fully upright for the cylinder to have vapor withdrawal only.



Correct



Wrong

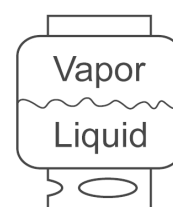

Wrong

! CAUTION



- a. Do not store a spare LP-gas cylinder under or near this appliance.
- b. Never fill the cylinder beyond 80 percent full.
- c. If the information in (a) and (b) is not followed exactly, a fire causing death or serious injury may occur.

OPERATION INSTRUCTIONS



⚠ WARNING

ALL INSTRUCTIONS AND SAFEGUARDS ON THIS PAGE MUST BE FOLLOWED TO PREVENT FIRE, DAMAGE AND/OR INJURY.

CONNECTING THE LP TANK

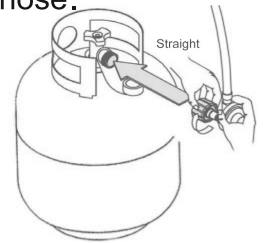
- The cylinder valve on the LP tank must be closed. Make sure that the cylinder valve is turned  clockwise to a full stop. The cylinder supply system must be arranged for vapor withdrawal.
- Check that the control knobs on the grill body are turned off.
- Remove the protective cap from the LP tank valve and the regulator valve of the hose.
- Hold the regulator valve in one hand and insert the nipple into the threaded valve outlet. Be sure the nipple is centered in the valve outlet. Use carefully – do not cross-thread the connection.
- Hand-tighten the regulator valve  clockwise until it comes to a full stop. Firmly tighten it by hand only. Do not use tools.



To Disconnect: Fully close the cylinder valve by turning  clockwise. Turn the regulator valve  counterclockwise until the regulator assembly detaches.

⚠ WARNING

In the connection process, make sure:

- the regulator valve inlet connector mates with the cylinder valve outlet properly, safely and firmly, and;
- the LP gas hose does not come in contact or remain in contact with the firebox.

OPERATION INSTRUCTIONS

Lighting The Grill

Before first use:

Remove all hangings or plastic straps, if present. Before you cook on your new gas grill, it is important to clean your grill with heat. To do this, operate the grill for approximately 15 minutes with the lid closed and the control knobs in the highest position. This will clean the internal parts by burning off any residue and odor from the manufacturing process.

! CAUTION

If the flame extinguishes accidentally during ignition or operation, immediately TURN OFF the cylinder valve and then TURN OFF the control knobs.

! WARNING

Read instructions before lighting.

1. Check that the control knobs are at the off position.
2. Open cylinder valve at tank fully by turning  counterclockwise.
3. Open the lid during lighting.
4. Hold down and turn the gas control knob anticlockwise to light the fire. If ignition does not take place within 5 seconds, immediately turn the control knob to the off position. Wait 5 minutes and repeat step 4 above or refer to lighting instructions in the manual.
5. Repeat step 4 above to ignite all other burners. If the burner still does not light, check that if there is gas in the cylinder and follow the fire rod/match lighting instructions.

Note: Check the Troubleshooting Guide on page 20 for more information.

OPERATION INSTRUCTIONS



LIGHTING THE GRILL WITH THE FIRE ROD/MATCH

1. Open the lid.
2. Insert the fire rod into the match holder or place a match between the circular wires.
3. Light the fire rod/match.
4. Make sure the lit rod/match is close to the burner port.
5. Press in the corresponding control knob and rotate  counter-clockwise. The burner should light immediately.
6. Repeat 2–5 steps to light the remaining burners.
7. Adjust burners to desired cooking settings.

CAUTION

Make sure all burners controls are off except for the burner being lit and the have been lit.

SHUTDOWN INSTRUCTIONS

1. Turn control knobs  clockwise to the off position.
2. Close cylinder valve of the tank fully by turning  clockwise.
3. Close the lid.

Turn off LP supply at the cylinder when the appliance is not in use.

CARE AND MAINTENANCE

Cooking Grates

The best time to "burn-off" the cooking grates is after every use (approx. 15 minutes). The grill is already hot from cooking thus requiring less fuel to obtain necessary temperature for "burn-off".

To "burn-off" or heat to clean your grill, turn the burners to highest position and run for 15 minutes with the lid closed. Then turn off the burners and use a wire brush to clean excess food residue from the grates.

⚠ CAUTION

Ensure the grill is cool before cleaning and conducting maintenance and with the gas supply turned off at the LP-Gas Cylinder.

Recommended Cleaning Supplies: Mild liquid dish soap, warm water, nylon cleaning pad, wire brush.

NOTE: DO NOT use cleaners that contain acid, mineral spirits or any abrasive substance.

Outside Surfaces

It is recommended to use only mild dish soap and hot water to clean grill and grill parts. Rinse with warm water.

Grill Heat Plate

Clean residue with wire brush and wash with mild dish soap and warm water. Rinse with warm water.

Oil Drip Box

Empty the oil drip box and clean with mild dish soap and warm water on a regular basis.

Checking The Flame

For maximum fuel efficiency and cooking performance, flame should be a blue-yellow color and be between 1-2 inches high. To check the flame, view the flame through the holes in both sides of the firebox.

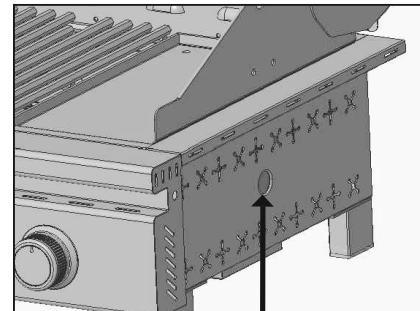

Hole for viewing the flame

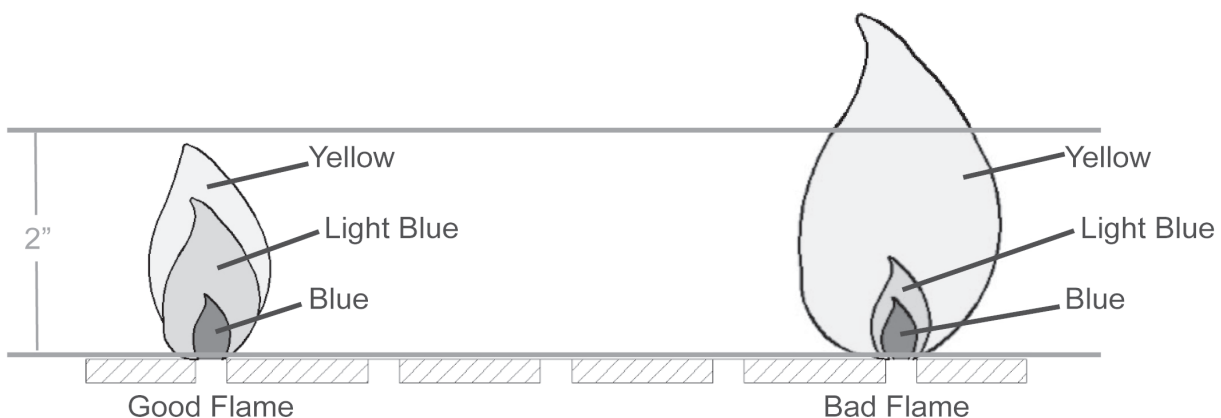

CARE AND MAINTENANCE

Removing The Burner Assembly - Make sure the grill is cool

1. Make sure all control knobs are in the off position, the gas supply valve is closed, and the gas hose is disconnected from the gas supply.
2. Remove the cooking grate, grill heat plates.
3. Remove the screws at end of the burner tubes as shown in the figure.
4. Slide the main burners out.
5. Detach the igniter wire from the burner tube. DO NOT use pliers or any other tool as it may damage the tube or wire.
6. Clear all burner ports of clogs. Use of a pin or a paper clip works well.
7. Ensure the burner is free of any damage. If any damage is found, replace it with a new burner.
8. Clear the end of the burner of insect nests, dirt or debris.

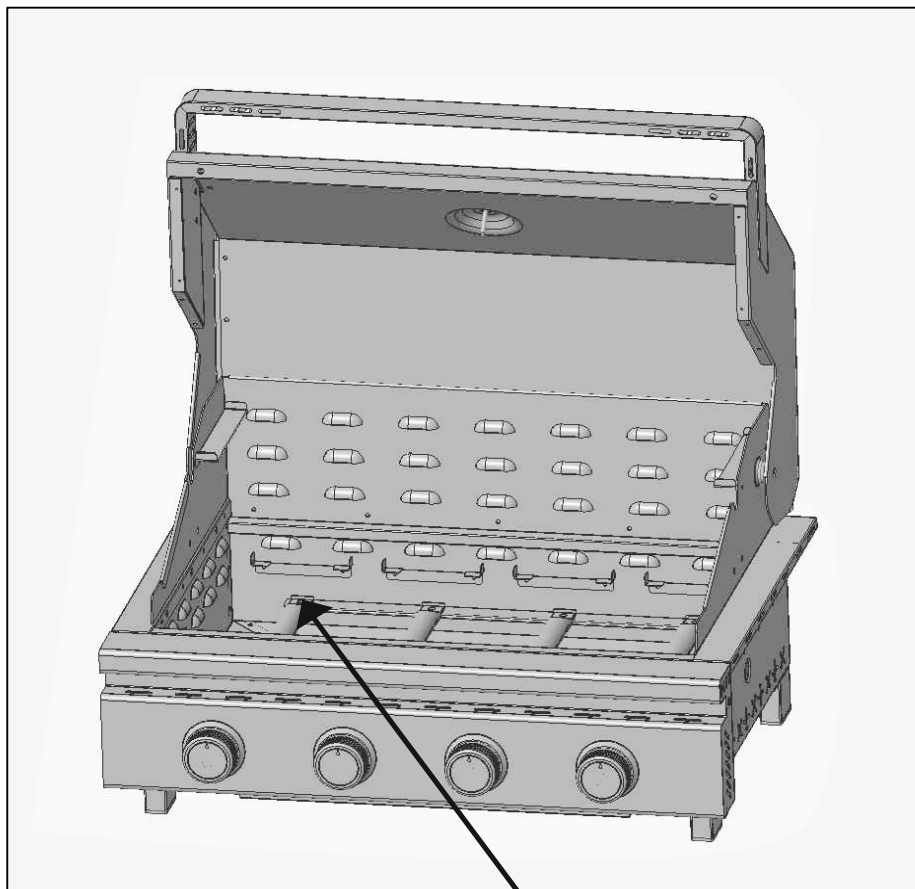

Screw

CARE AND MAINTENANCE

Re-installing the Burner Assembly

1. Ensure that gas valve orifices inside the grill body are correctly positioned inside burner inlet (venturi). It is recommended that view the correct position from the bottom of the grill.
2. The use of a flashlight may be necessary to ensure the correct position.
3. It is recommended to view the correct position through the vent holes of the grill body as shown in the figure below.
4. Reattach each burner with the screw and reattach the igniter wire to burner tube.

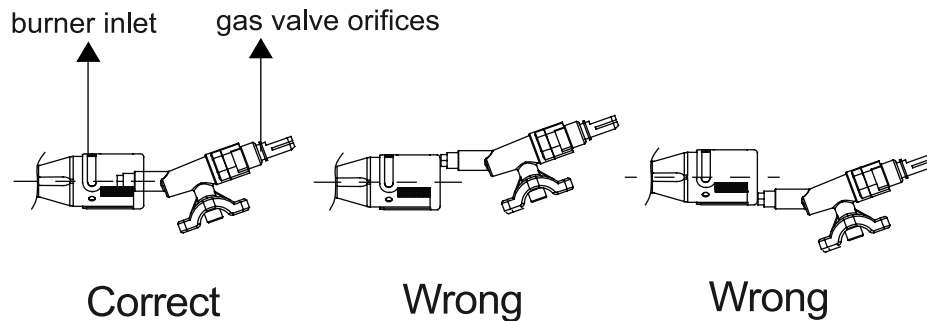

!WARNING

If the instructions above are not followed, a fire or explosion may result, possibly causing serious bodily injury.

Other Care and Maintenance

Maintenance Instructions (including recommended frequency guidelines) relative to:

- 1) Keeping gas appliance areas clear and free from combustible materials, gasoline, and other flammable vapors and liquids.
 - 2) Not obstructing the flow of combustion and ventilation air.
 - 3) Keeping the ventilation opening(s) of the cylinder enclosure free and clear from debris.
 - 4) Visually checking burner flames including pilot burner flame if provided.
 - 5) Checking and cleaning burner/venturi tubes for insects and insect nests. A clogged tube can lead to a fire beneath the grill.
- * It is highly recommended to conduct maintenance at least once a year.

TROUBLESHOOTING

If you have any questions regarding the product, please call customer service at 818-468-1498.

PROBLEM	POSSIBLE CAUSE	CORRECTIVE ACTION
The burner does not light by using the ignition procedure(weak or no sparking generated).	<ol style="list-style-type: none">1. The burner tube may be covered with grease or residue.2. The burner tube may have a loose or disconnected wire.3. Cracked or broken burner tube.	<ol style="list-style-type: none">1. Clean the burner tube.2. Check the connection and reconnect any loose or disconnected wire.3. Replace the burner tube.
Low Heat.	Insufficient gas pressure to the unit.	Call a qualified service agency to check the gas supply pressure and correct the pressure.
Excessive Flare Ups.	<ol style="list-style-type: none">1. Grease and/or residue build-up on grill heat plates or in firebox.2. Excessive dripping of fat or marinade from food.3. Cooking temperature is too high.	<ol style="list-style-type: none">1. Clean the grill components.2. Shed the fat from meat and use non-oil based marinades.3. Lower temperature accordingly.

TROUBLESHOOTING

PROBLEM	POSSIBLE CAUSE	CORRECTIVE ACTION
<p>The burner will not light with the fire rod.</p>	<ol style="list-style-type: none"> 1. The rod does not reach burners. 2. Empty tank. 3. Poor connection between the regulator valve and the propane cylinder or the threaded valve of the LP gas cylinder. 4. Burner inlet blocked. 	<ol style="list-style-type: none"> 1. Use the fire rod correctly as instructed in LIGHTING THE GRILL WITH THE FIRE ROD /MATCH section. 2. Check the fuel level and replace the tank if necessary. 3. Turn off grill knobs first. Check the connection between the regulator valve and the propane cylinder. Or close the cylinder valve of the LP gas tank and check the connection between the regulator valve and the threaded valve of the LP gas tank. 4. Clean the burner inlet (venturi) and the burner as described by Care and Maintenance section in the manual.
<p>No gas flow or an obstructed gas flow.</p>	<ol style="list-style-type: none"> 1. Cylinder valve is not on or fully opened. 2. Empty tank. 3. Poor connection between the regulator valve and the propane cylinder or the threaded valve of the LP gas cylinder. 4. Burner inlet is blocked. 5. Wrong connection 	<ol style="list-style-type: none"> 1. Fully open the cylinder valve by turning counterclockwise. 2. Check the fuel level and replace the fuel if necessary. 3. Turn off grill knobs first. Check the connection between the regulator valve and the propane cylinder. Or close the cylinder valve of the LP gas tank and check the connection between the regulator valve and the threaded valve of the LP gas tank. 4. Clean the burner inlet (venturi) and burners as described by Care and Maintenance section in the manual. 5. Connect the regulator valve and the propane cylinder or the LP gas tank using the correct method as shown in step H or I in the ASSEMBLY INSTRUCTIONS section.

NOTICE: Some states do not allow the exclusion or limitation of incidental or consequential damages or limitations on how long an implied warranty lasts, so the above limitations or exclusions may not apply to you. This warranty gives you specific legal rights and you may also have other legal rights which may vary from state to state.

Thank you for purchasing this product! If you have any question about the product such as missing parts, damaged products, product assembling, operation, etc., please contact us via our customer service phone: **818-468-1498**.

IMPORTANT

Simply call our customer service department for any consulting:

818-468-1498

(8:30am - 5:30pm P.S.T.)

DATED PROOF OF PURCHASE IS REQUIRED FOR WARRANTY SERVICE.

AVIS

Veillez appeler le service à la clientèle pour toutes questions au:

818-468-1498

(8:30am - 5:30pm P.S.T.)

PREUVE D'ACHAT ORIGINALE REQUISE POUR SERVICE DE GARANTIE.

IMPORTANTE

Sólo hay que llamar nuestro departamento de servicio al cliente en caso de tener preguntas o inquietudes:

818-468-1498

(8:30am - 5:30pm P.S.T.)

SE REQUIERE PRUEBA DE COMPRA CON FECHA PARA SERVICIO BAJO GARANTÍA.

ROWAN ELECTRIC APPLIANCE LLC

818-468-1498