

SKU: D950116414 / D950116415

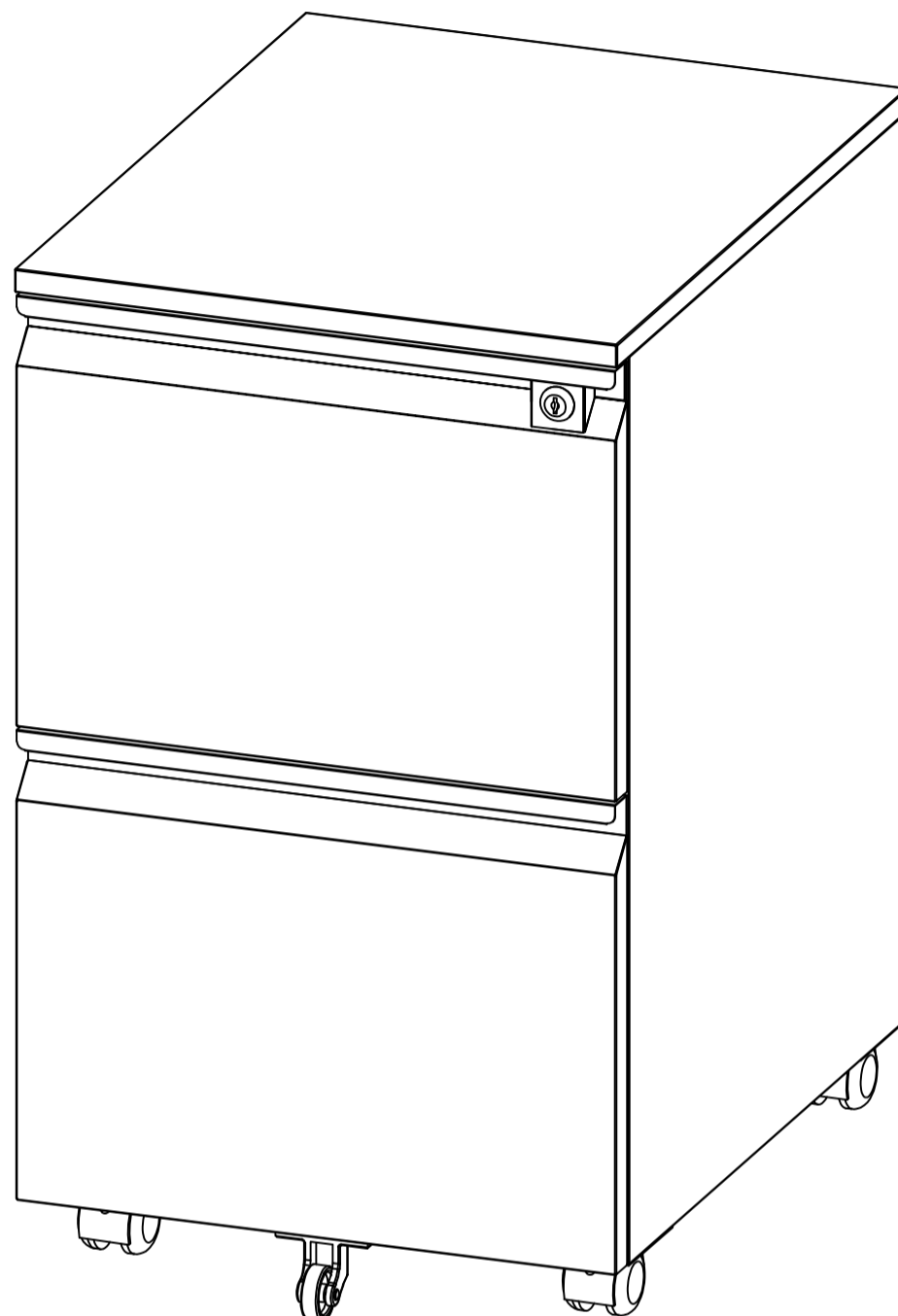

**NOTE: PLEASE AN ASSISTANT IS REQUIRED
ES NECESARIO UN AYUDANTE UN ASSISTANT
ES TNECESSAIRE.**



**Please scan the QR code to
check the assemble video**

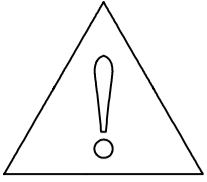

WARNING!

Important information, please read carefully and retain this information for future reference. Only adults are allowed to assemble, keep children away.

English WARNING!

If furniture is tipped over, it may cause serious injury or even death. To prevent tip-over of this furniture, be sure to use it with the wall attachment devices provided. Use the appropriate screws and plugs for your wall.

If the supplied wall attachment devices do not match the walls in your home, consult your local professional to use screws and plugs that fit your walls. Please read and follow each step in the instructions carefully.

Please pay attention to the iron corner protectors and cabinet parts inside the package. If the iron corner guard is damaged, you can just discard it; if you find any broken or damaged cabinet parts, please contact customer service immediately for replacement. Sharp edges of metal parts can cause serious injury.

Please pay attention to the glass parts of the cabinet (if included). If you find any broken or damaged parts, contact customer service immediately for replacement. Sharp edges of the glass may cause serious injury.

Deutsch WARNUNG!

Wenn Möbel umkippen, kann dies zu schweren Verletzungen oder sogar zum Tod führen. Um ein Umkippen dieser Möbel zu verhindern, verwenden Sie unbedingt die mitgelieferten Wandbefestigungsvorrichtungen. Verwenden Sie geeignete Schrauben und Dübel für Ihre Wand.

Wenn die mitgelieferten Wandbefestigungsvorrichtungen nicht zu Ihren Wänden passen, konsultieren Sie einen Fachmann vor Ort, um passende Schrauben und Dübel zu verwenden. Bitte lesen und befolgen Sie die Anweisungen Schritt für Schritt sorgfältig.

Achten Sie auf die eisernen Eckenschützer und Schrankteile in der Verpackung. Wenn der eiserne Eckenschutz beschädigt ist, können Sie ihn einfach entsorgen. Wenn Sie beschädigte Schrankteile finden, kontaktieren Sie sofort den Kundendienst für Ersatz. Scharfe Kanten an Metallteilen können schwere Verletzungen verursachen.

Achten Sie auf die Glasteile des Schrankes (falls enthalten). Bei gebrochenen oder beschädigten Teilen kontaktieren Sie umgehend den Kundendienst für Ersatz. Scharfe Glasränder können schwere Verletzungen verursachen.

Français AVERTISSEMENT!

Si un meuble bascule, cela peut entraîner des blessures graves ou même la mort. Pour éviter le basculement de ce meuble, veuillez à utiliser les dispositifs de fixation murale fournis. Utilisez des vis et chevilles adaptées à votre mur.

Si les dispositifs de fixation fournis ne correspondent pas à vos murs, consultez un professionnel local pour utiliser des vis et chevilles adaptées. Veuillez lire et suivre attentivement chaque étape des instructions.

Portez une attention aux protections d'angle en fer et aux éléments du meuble dans l'emballage. Si la protection d'angle en fer est endommagée, vous pouvez simplement la jeter. Si des éléments du meuble sont cassés, contactez immédiatement le service client pour remplacement. Les arêtes vives des pièces métalliques peuvent causer de graves blessures.

Soyez attentif aux parties en verre du meuble (si incluses). Si des éléments en verre sont cassés, contactez immédiatement le service client pour remplacement. Les bords tranchants du verre peuvent provoquer de graves coupures.

italiano

AVVERTENZA!

Se i mobili si ribaltano, potrebbero causare gravi infortuni o persino la morte. Per prevenire il ribaltamento, utilizzare sempre i dispositivi di fissaggio a muro forniti. Usare viti e tasselli adatti alla vostra parete.

Se i dispositivi di fissaggio forniti non sono compatibili con le vostre pareti, consultate un professionista locale per utilizzare viti e tasselli adatti. Leggere e seguire attentamente ogni passaggio delle istruzioni.

Prestare attenzione agli angolari in ferro e ai componenti dell'armadio nella confezione. Se l'angolare in ferro è danneggiato, può essere scartato. Se trovate componenti rotti, contattate immediatamente l'assistenza clienti per la sostituzione. I bordi affilati delle parti metalliche possono causare gravi ferite.

Attenzione alle parti in vetro dell'armadio (se incluse). Se riscontrate danni, contattate subito l'assistenza clienti per la sostituzione. I bordi taglienti del vetro possono provocare gravi lesioni.

Español

ADVERTENCIA!

Si los muebles se vuelcan, pueden causar lesiones graves o incluso la muerte. Para evitar el vuelco, asegúrese de usar los dispositivos de fijación a la pared proporcionados. Utilice tornillos y tacos adecuados para su pared.

Si los dispositivos de fijación suministrados no coinciden con sus paredes, consulte con un profesional local para usar tornillos y tacos apropiados. Lea y siga cuidadosamente cada paso de las instrucciones.

Preste atención a los protectores de esquina de hierro y las partes del armario en el paquete. Si un protector de esquina está dañado, puede desecharlo. Si encuentra piezas rotas, contacte inmediatamente al servicio de atención al cliente para reemplazo. Los bordes afilados de metal pueden causar lesiones graves.

Revise las partes de vidrio del armario (si están incluidas). Si encuentra vidrios rotos, contacte inmediatamente al servicio de atención al cliente. Los bordes afilados del vidrio pueden causar cortes graves.

한국어 경고!

가구가 넘어질 경우 심각한 부상이나 사망에 이를 수 있습니다. 이 가구의 전도를 방지하려면 제공된 벽 고정 장치를 반드시 사용하십시오. 벽면에 적합한 나사와 플러그를 사용하세요.

제공된 벽 고정 장치가 집 벽면과 맞지 않을 경우, 현지 전문가와 상담하여 적합한 나사와 플러그를 사용하십시오. 설명서의 각 단계를 주의 깊게 읽고 따르십시오.

포장 내 철제 모서리 보호대와 캐비닛 부품에 주의하십시오. 철제 모서리 보호대가 손상된 경우 폐기하면 되며, 캐비닛 부품이 파손되었을 경우 즉시 고객 서비스에 연락하여 교체를 요청하십시오. 금속 부품의 날카로운 모서리는 심각한 부상을 유발할 수 있습니다.

캐비닛 유리 부품(포함된 경우)을 확인하십시오. 파손된 유리 부품이 발견될 경우 즉시 고객 서비스에 연락하여 교체를 요청하십시오. 유리의 날카로운 모서리는 심각한 상처를 입힐 수 있습니다.

日本語

警告!

家具が転倒した場合、重大な怪我や死亡事故につながる可能性があります。転倒を防ぐため、付属の壁固定器具を必ずご使用ください。ご使用の壁に適したネジとプラグを選択してください。

付属の壁固定器具がご自宅の壁に合わない場合は、地元の専門家に相談し、適切なネジとプラグをご使用ください。説明書の各手順を注意深くお読みの上、厳守してください。

パッケージ内の鉄製コーナーガードとキャビネット部品にご注意ください。鉄製コーナーガードが破損している場合は廃棄してください。キャビネット部品に破損がある場合は、直ちにカスタマーサービスに連絡し交換品をご請求ください。金属部品の鋭利な縁は深刻な怪我を引き起こす可能性があります。

キャビネットのガラス部品(付属の場合)に欠陥がある場合は、直ちにカスタマーサービスにご連絡ください。ガラスの鋭利な縁は重大な外傷の原因となる可能性があります。

Before you start, here are a few quick pointers:

The installation requires two people. so call a friend to join the fun!

For more stability, it's best to anchor the cabinet to the wall.

In this case, along with the items provided you will also need a Level, Percussion Drill and a Hammer

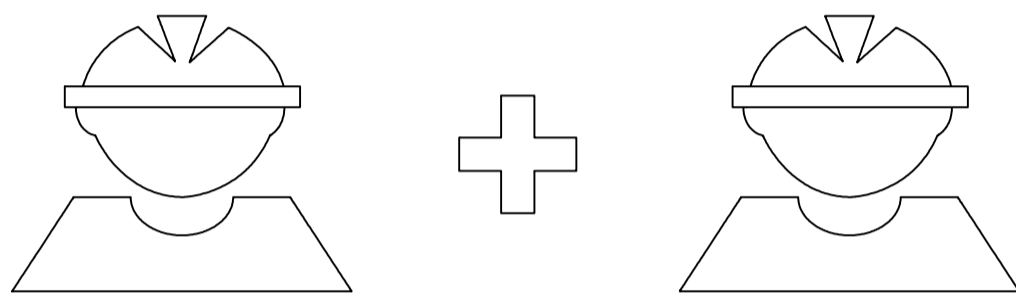

SUGGEST
2 PEOPLE

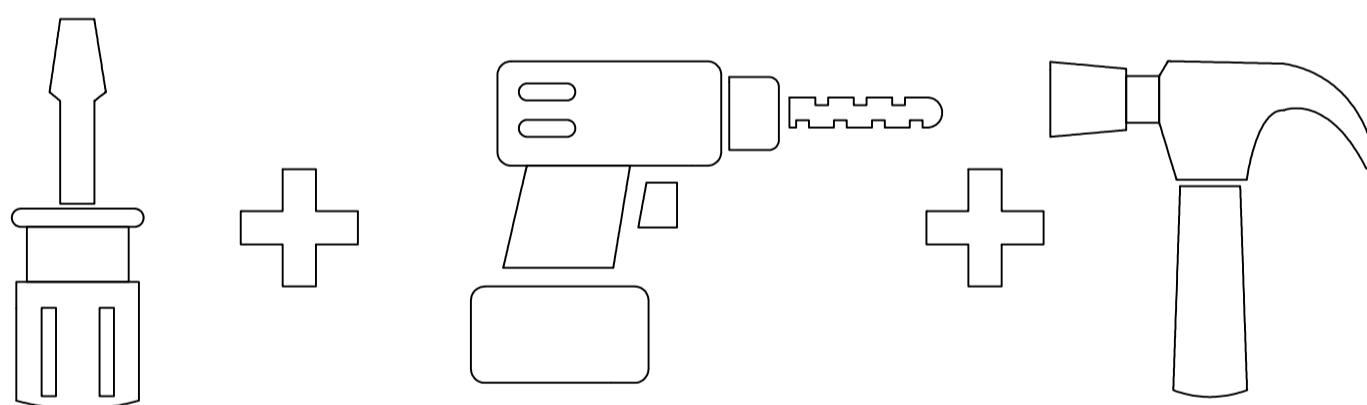

TOOLS
REQUIRED

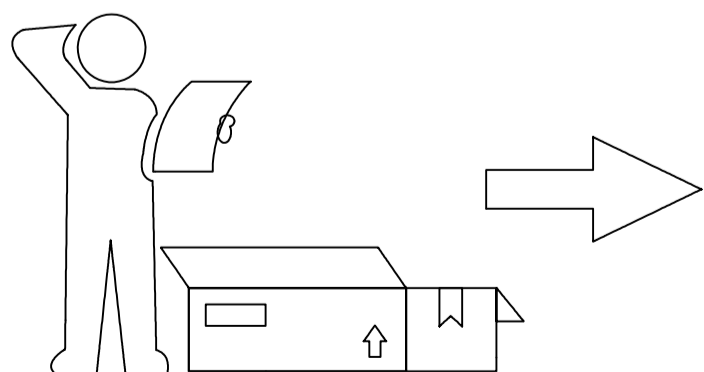

E-mail	<input type="text"/>
TEL	<input type="text"/>
<input type="button" value="CONTACT US"/>	

WE ARE
GLAD TO
HELP

THANK YOU FOR CHOOSING US!

Your new Movable cabinet has arrived and it will make your life so much easier. That's why we put so much effort into designing it to perfectly fit your needs.

But first things first, we need to install it!

When we say we, we mean we're going to guide you, step by step. We created this instructions manual so that you won't feel overwhelmed and get your new cabinet up and ready to use in no time! We also know that if sometimes things just don't seem to fit, so don't hesitate to drop us a line at support@greatmeetcabinet.com if you have questions or need help!

Anyway, this movable cabinet can't wait to be put into use, so let's assemble it!

MISSING A PART?

DON'T WORRY, WE GOT YOUR BACK!

Compare the sketch on the next page with your package. Are all the pieces there? However, sometimes errors happen, so if anything is missing just send us an email and we will make sure to fix it!

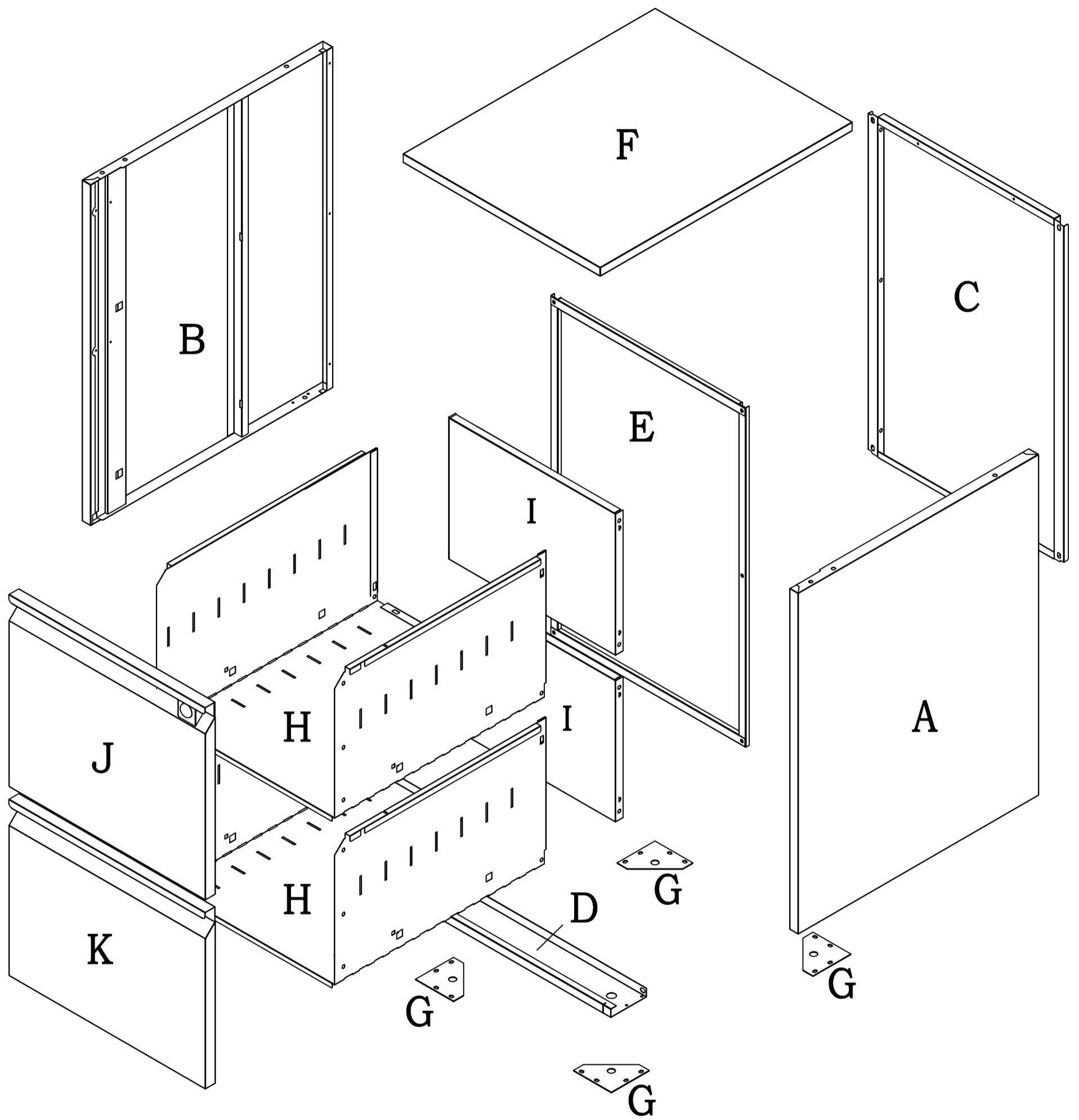

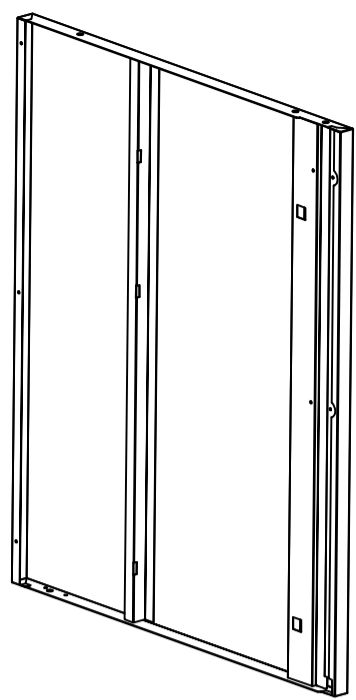

A x1

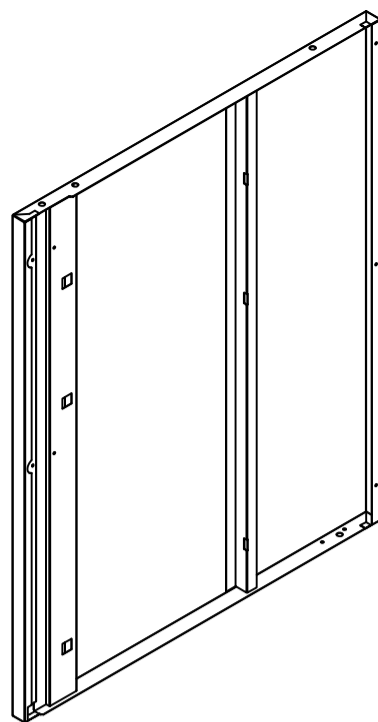

B x1

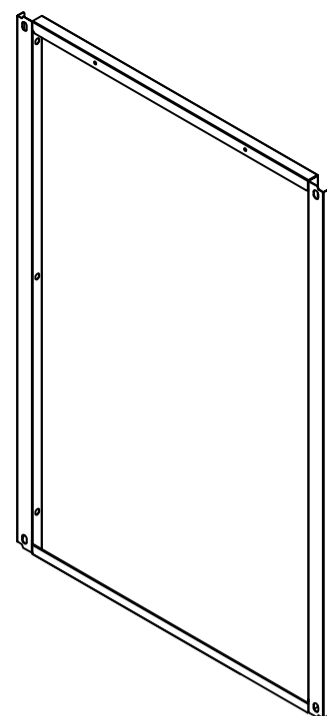

C x1

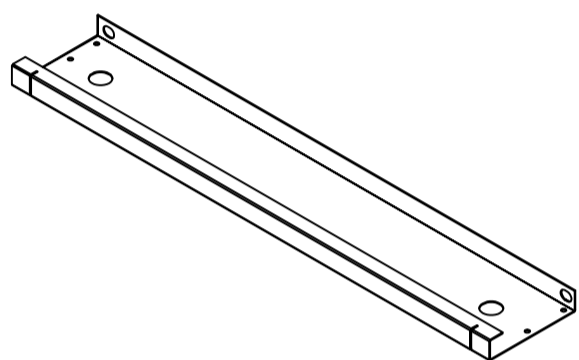

D x1

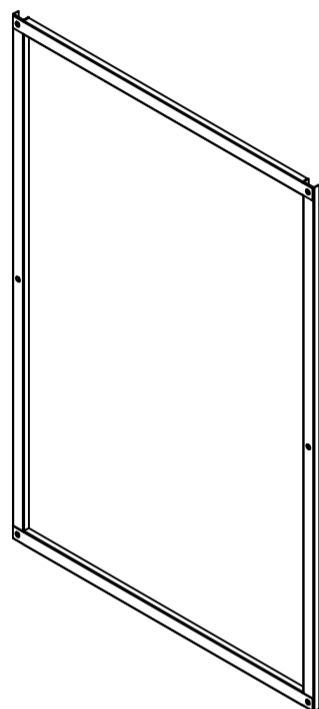

E x1

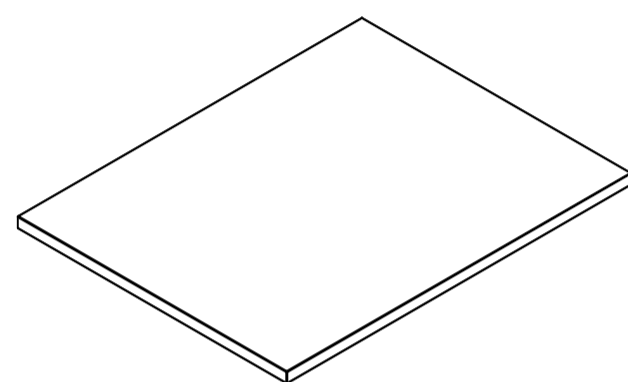

F x1

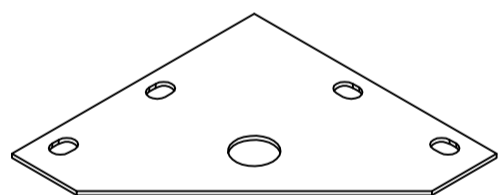

G x4

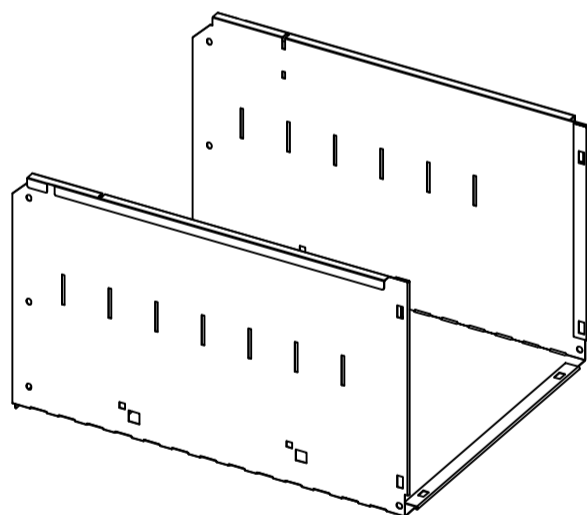

H x2

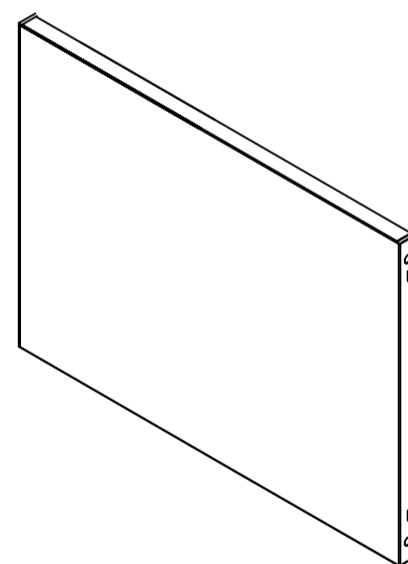

I x2

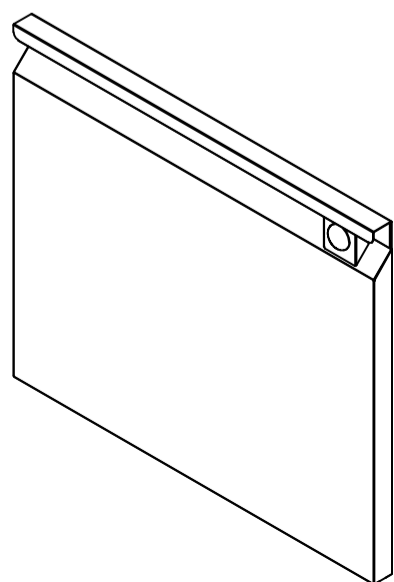

J x1

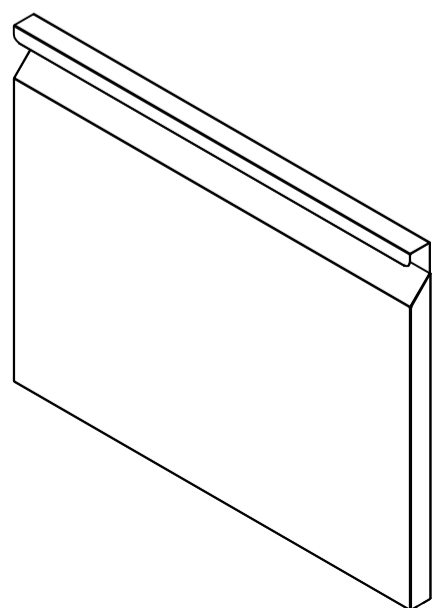

K x1

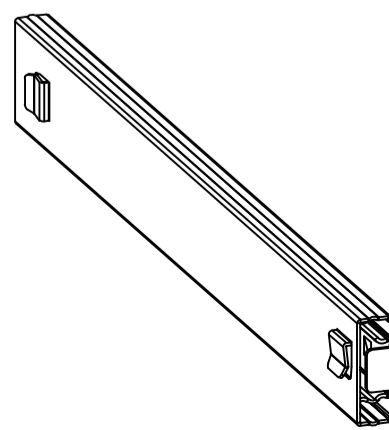

L x2

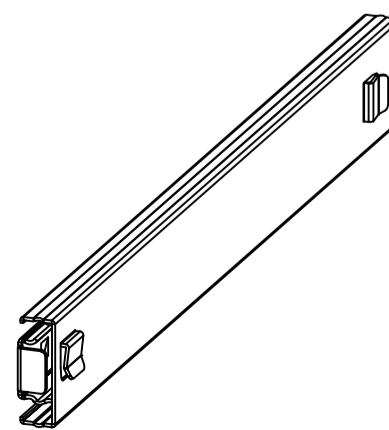

R x2

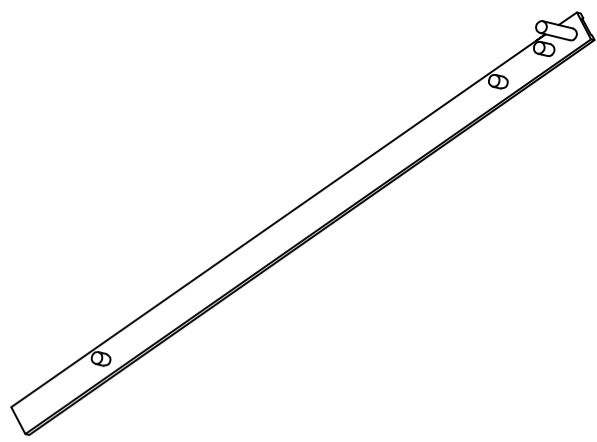

① x1

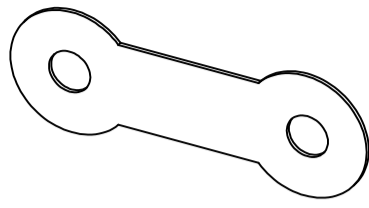

② x2

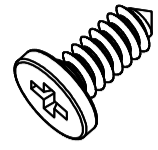

③ x4

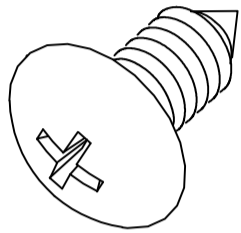

M5 x10

④ x50

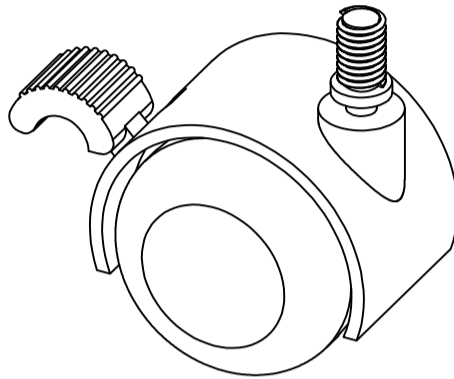

⑤ x2

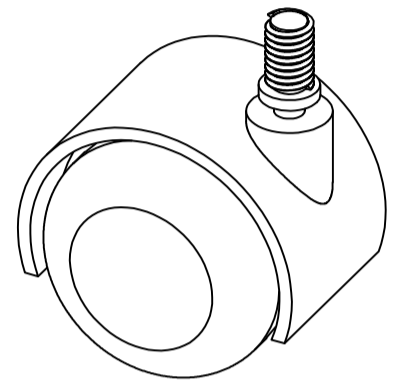

⑥ x2

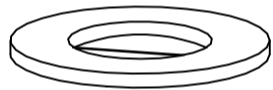

⑦ x4

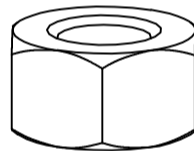

⑧ x4

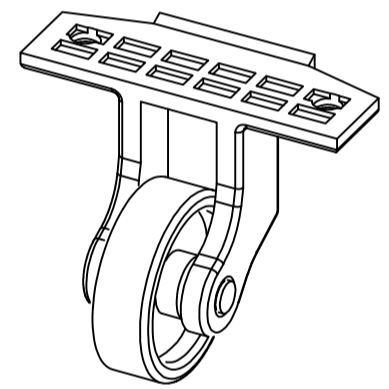

⑨ x1

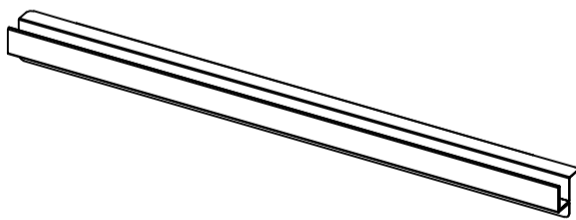

⑩ x4

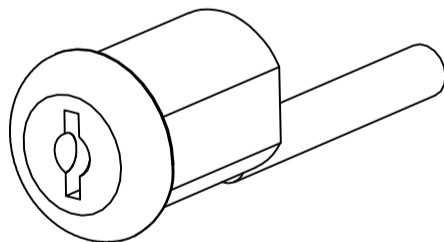

⑪ x1

01

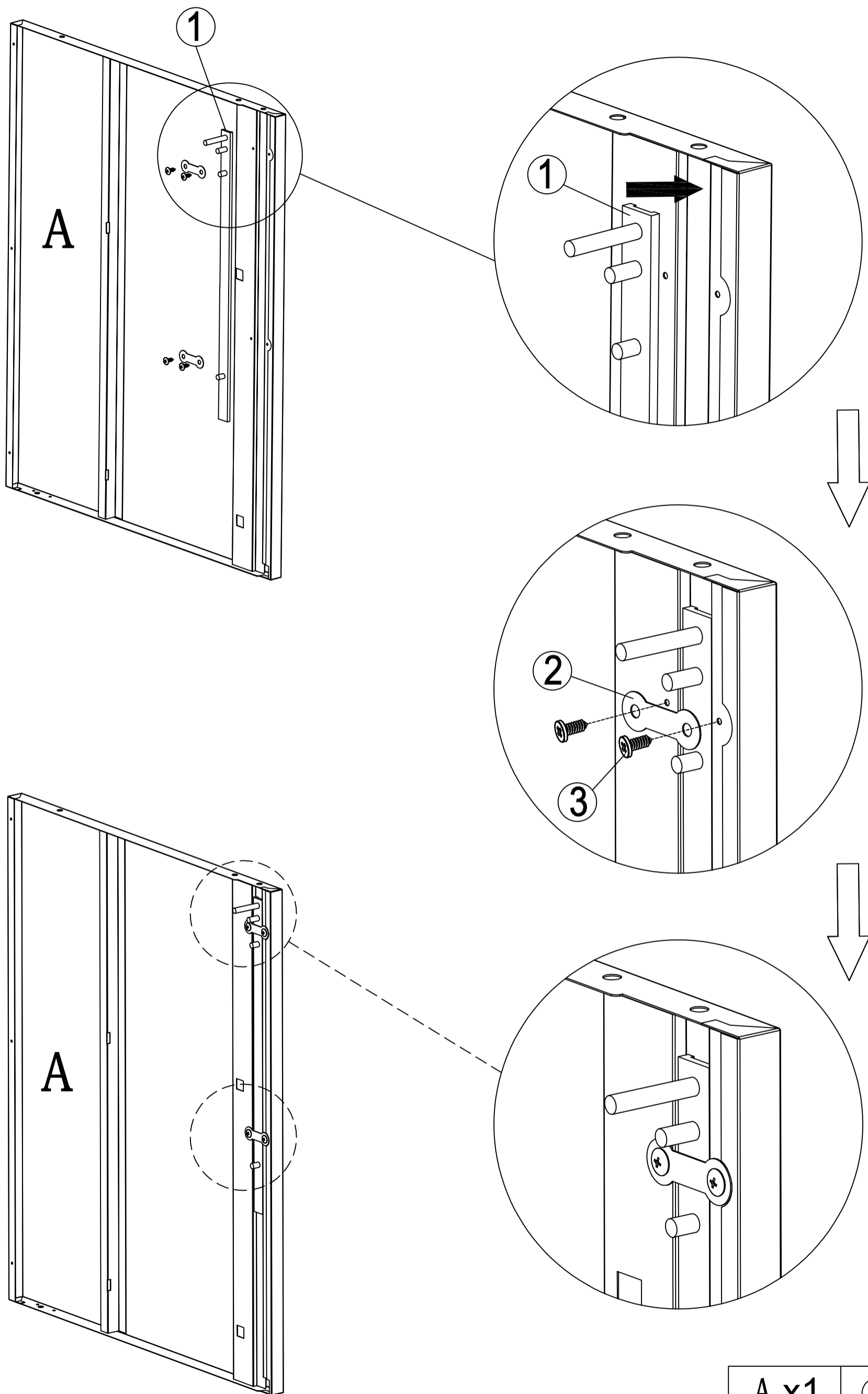

A x1	① x1
② x2	③ x4

1. Assemble A and 1, fix them with 2 and 3.

02

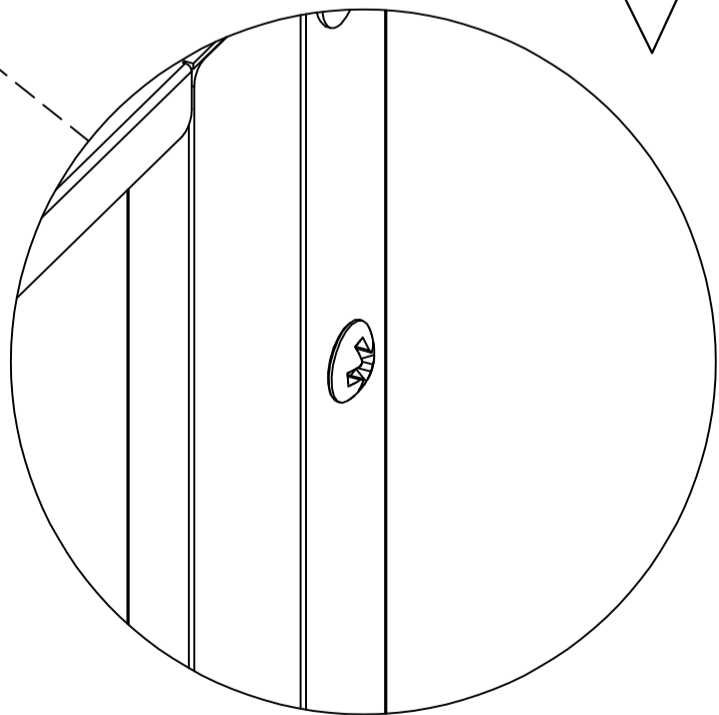
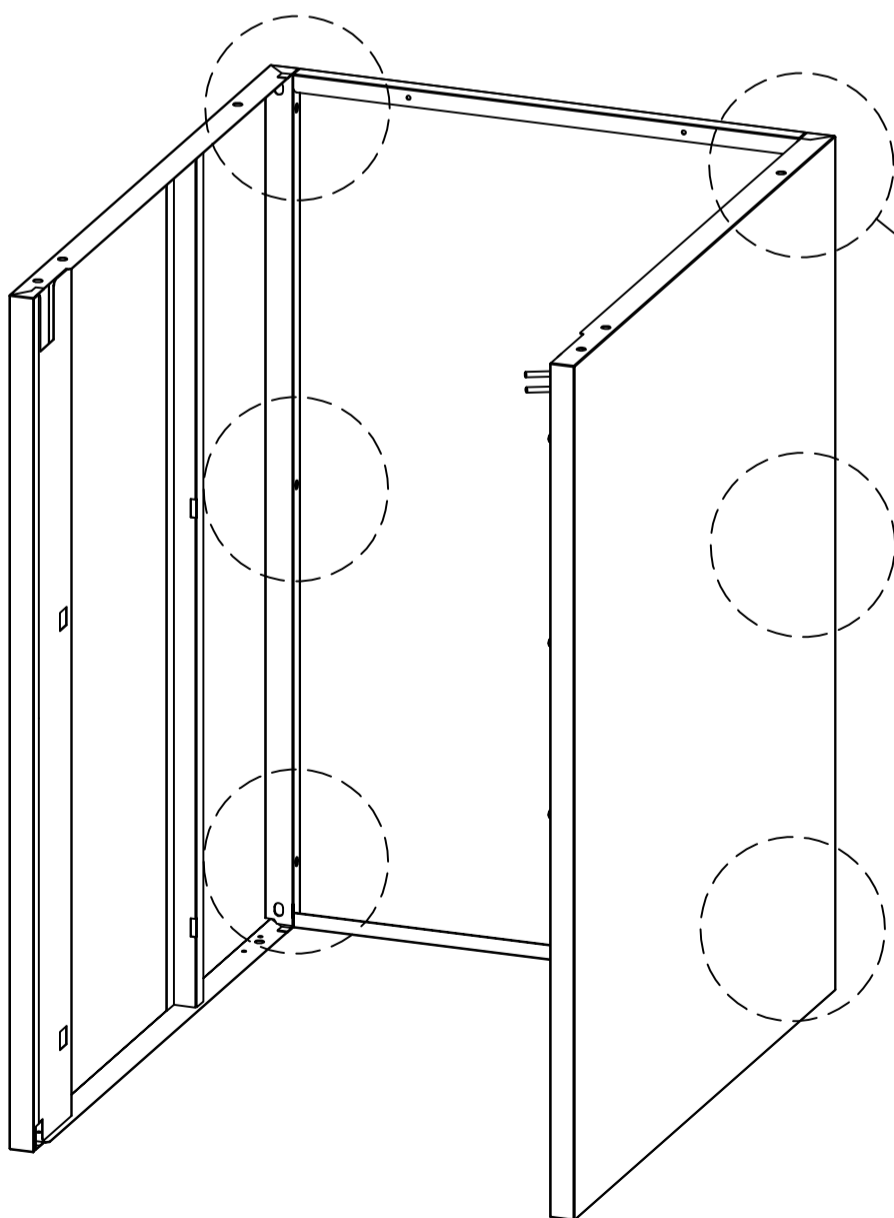
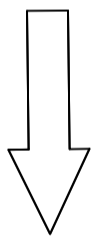
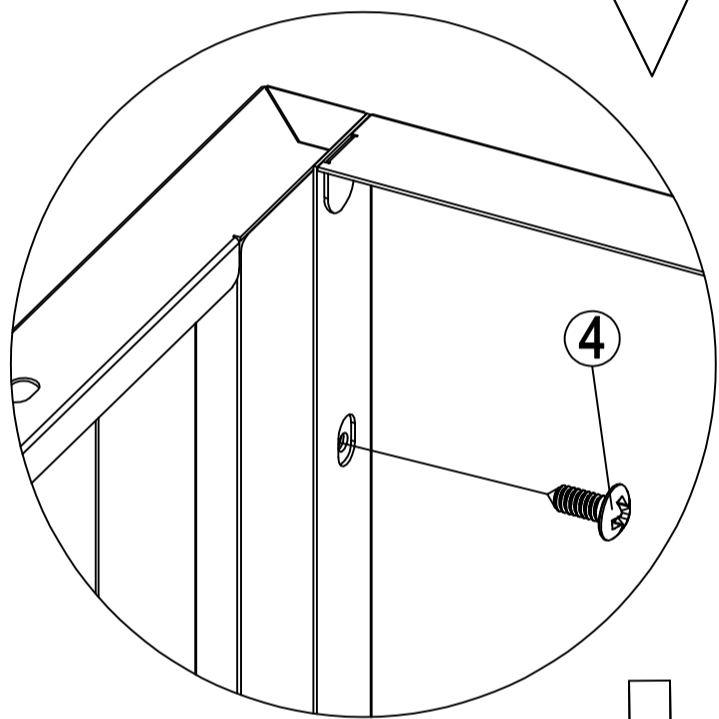
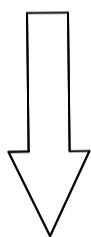
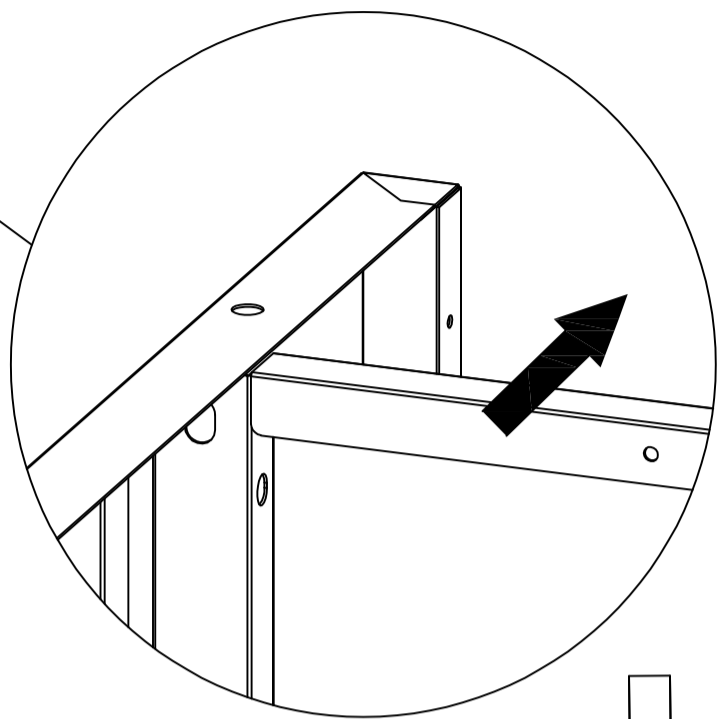
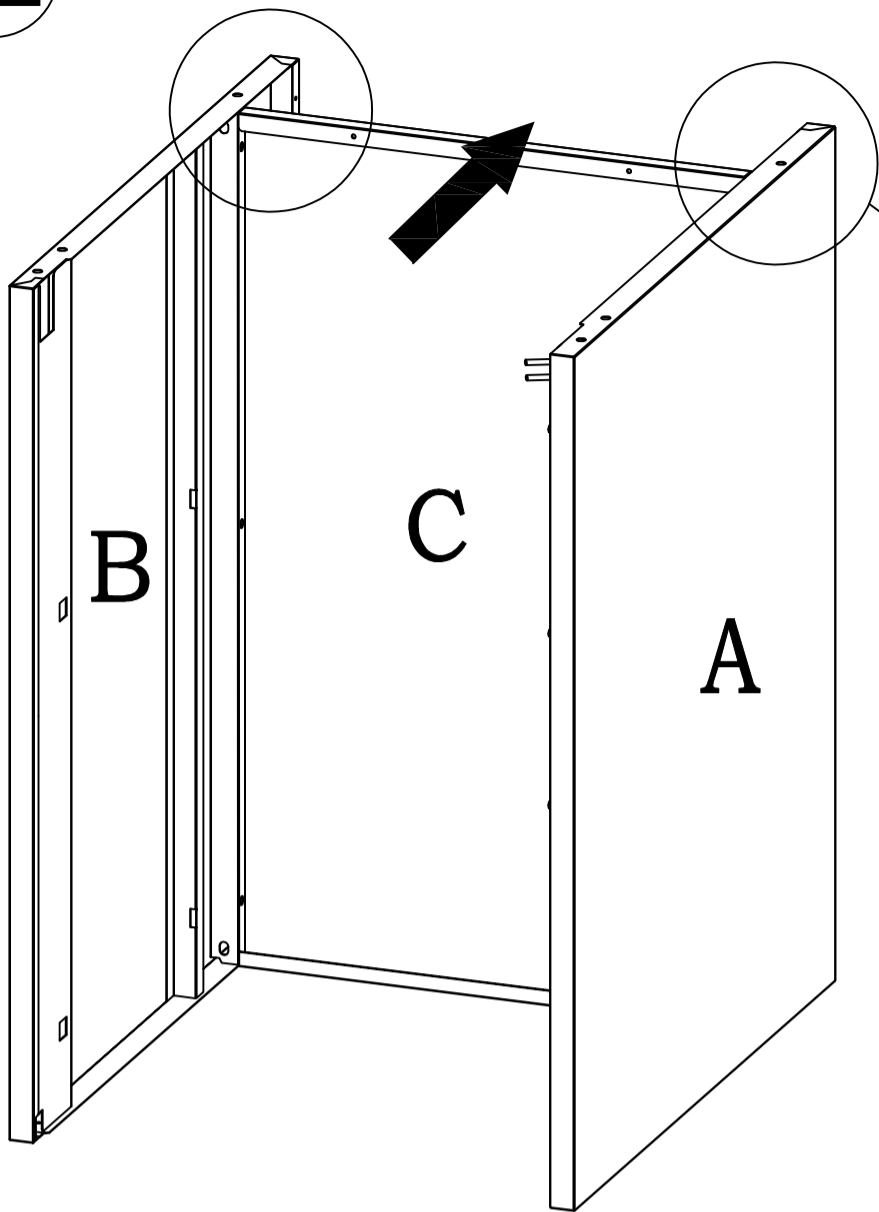

④ x6

2. Assemble A, B and C, secure with screw 4.

03

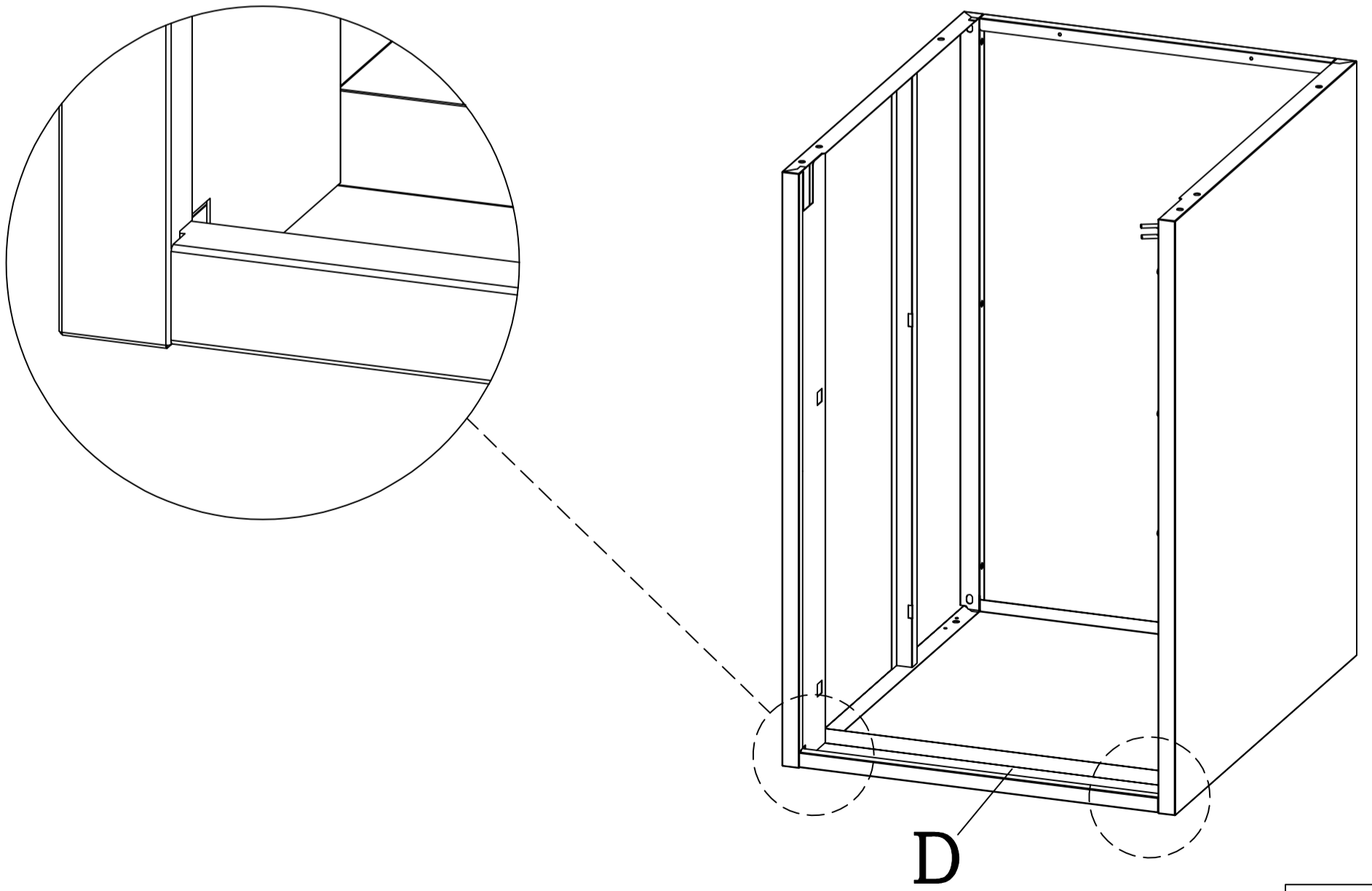
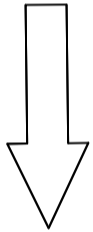
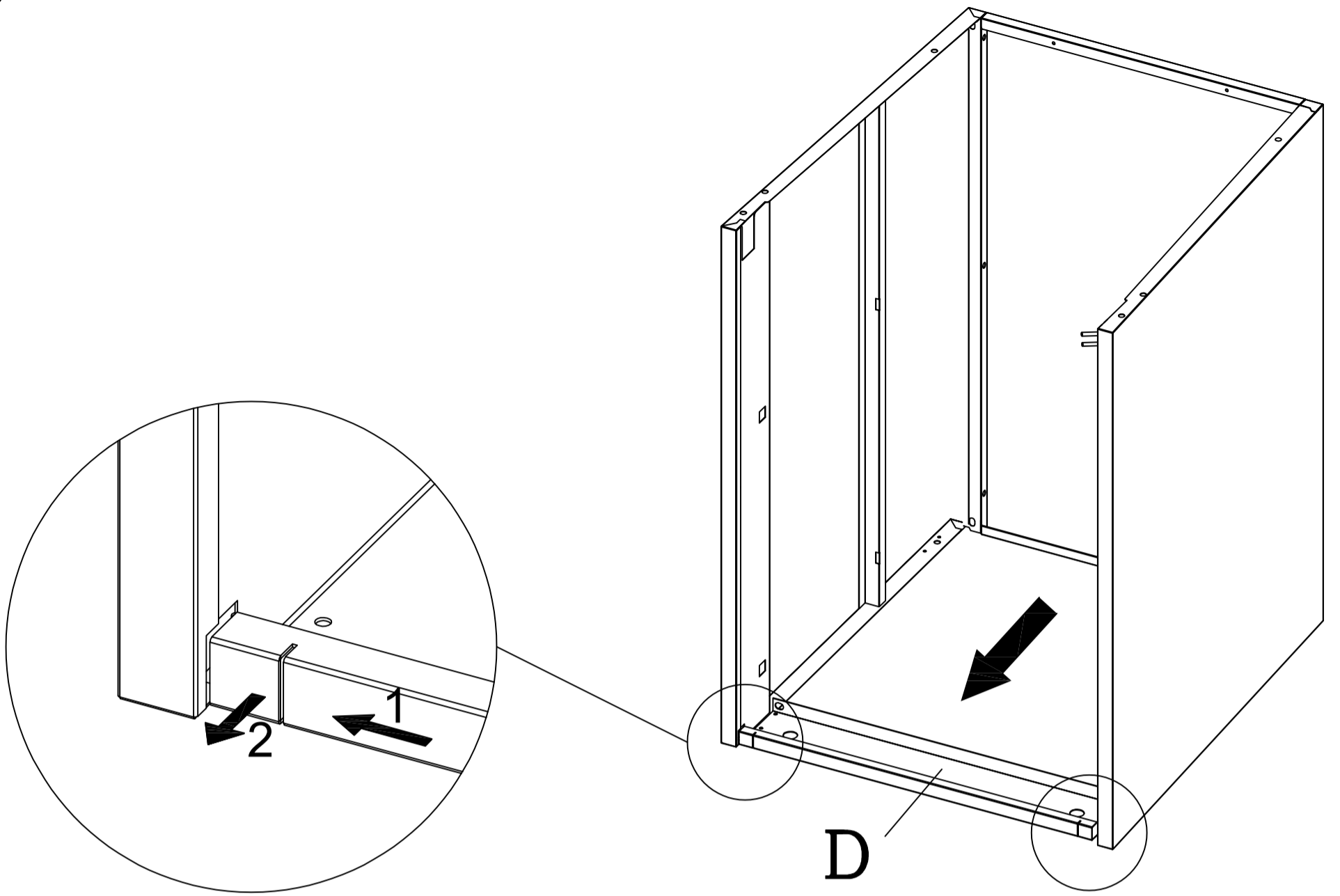

D x1

3. Assemble D.

04

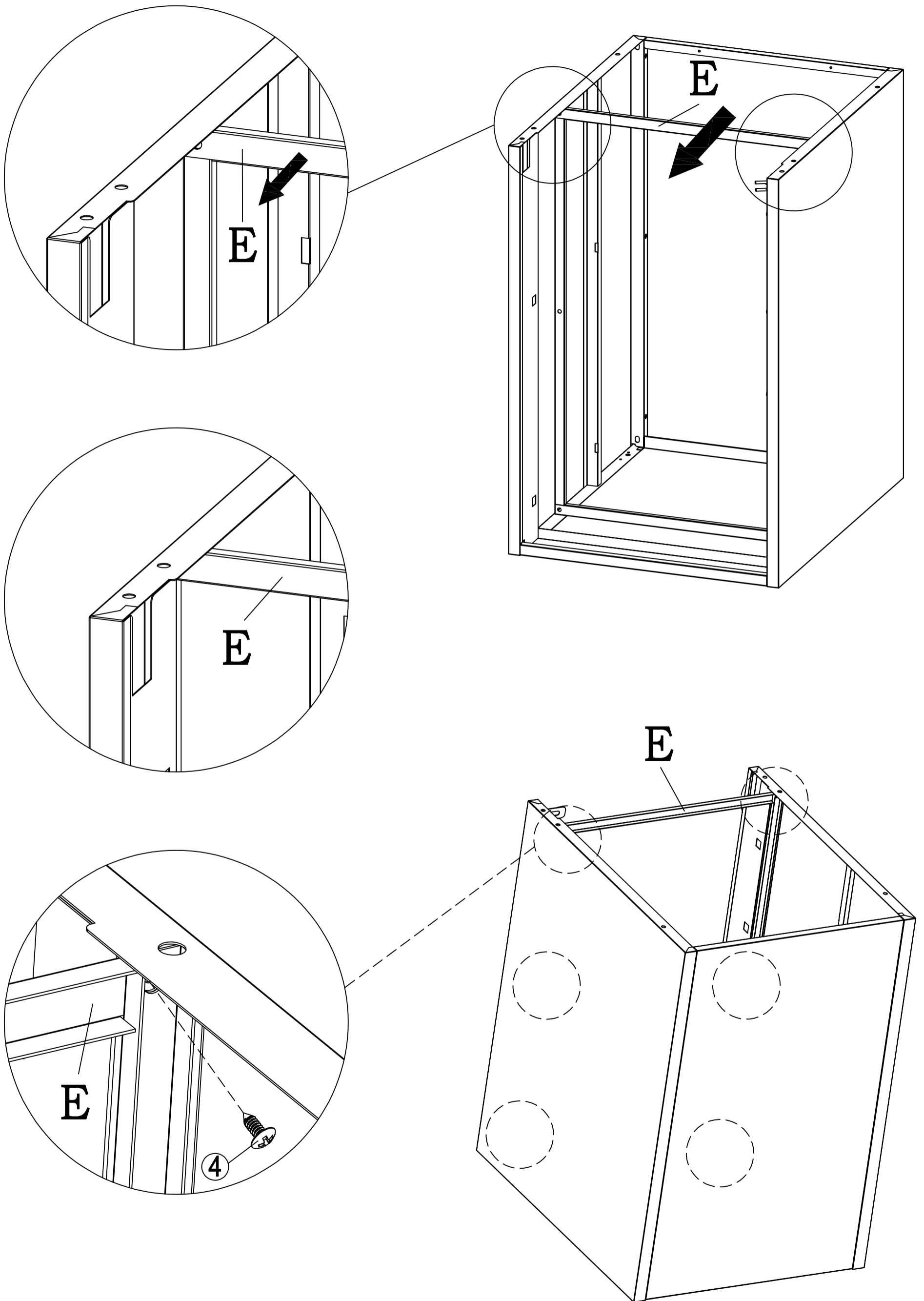

④ x6

4. Assemble E, secure with screw 4.

05

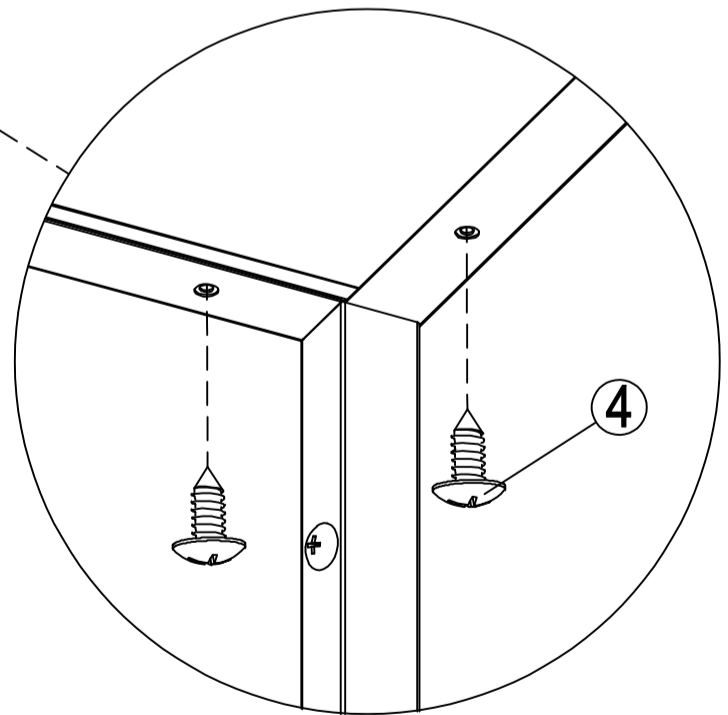
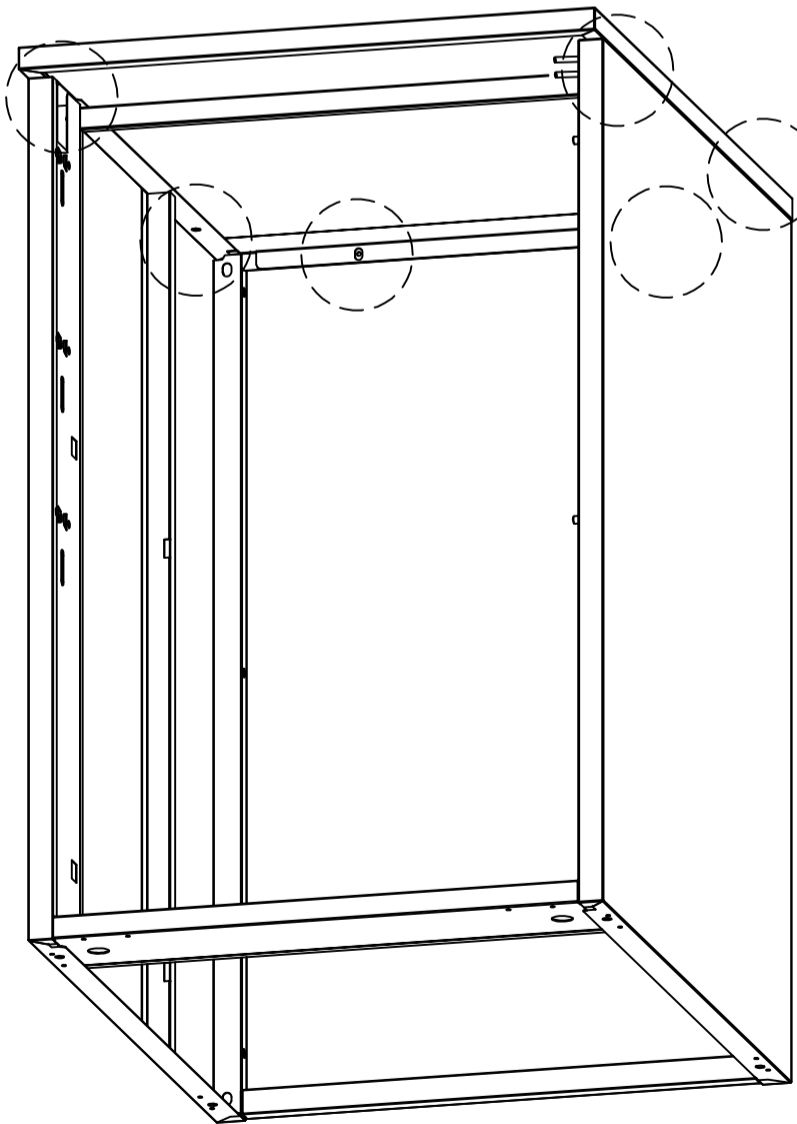
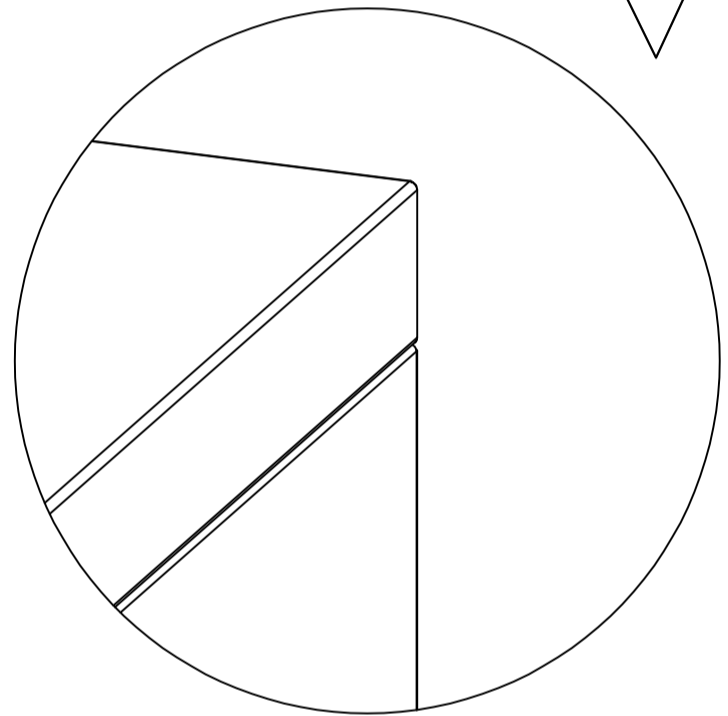
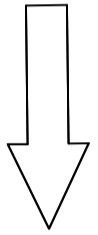
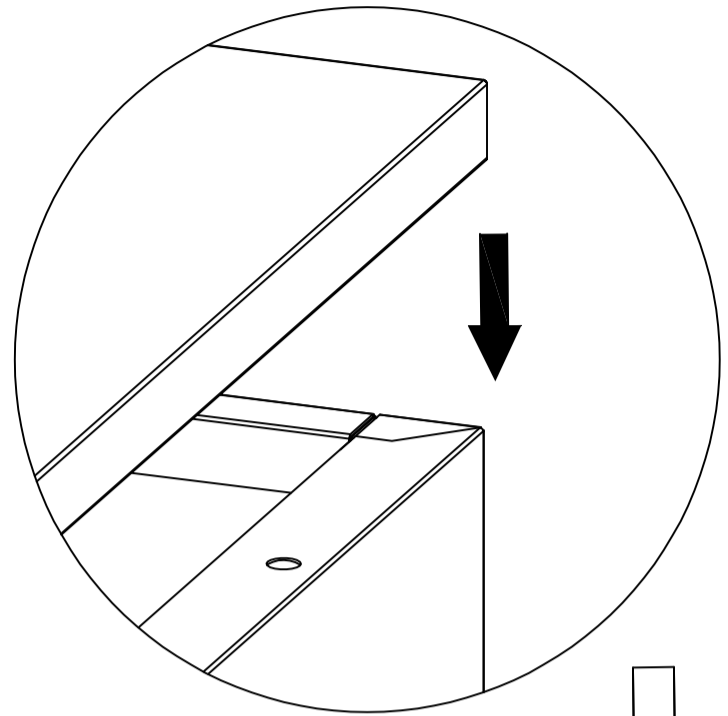
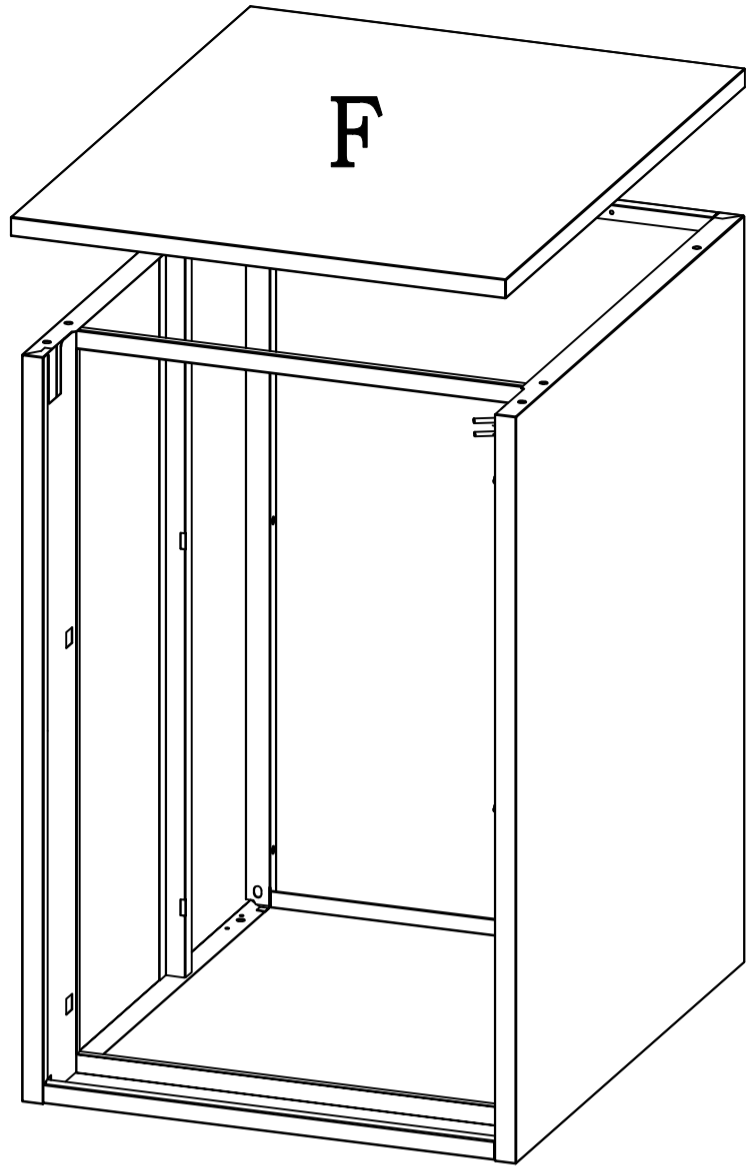

④ x6

5. Assemble F, secure with screw 4.

06

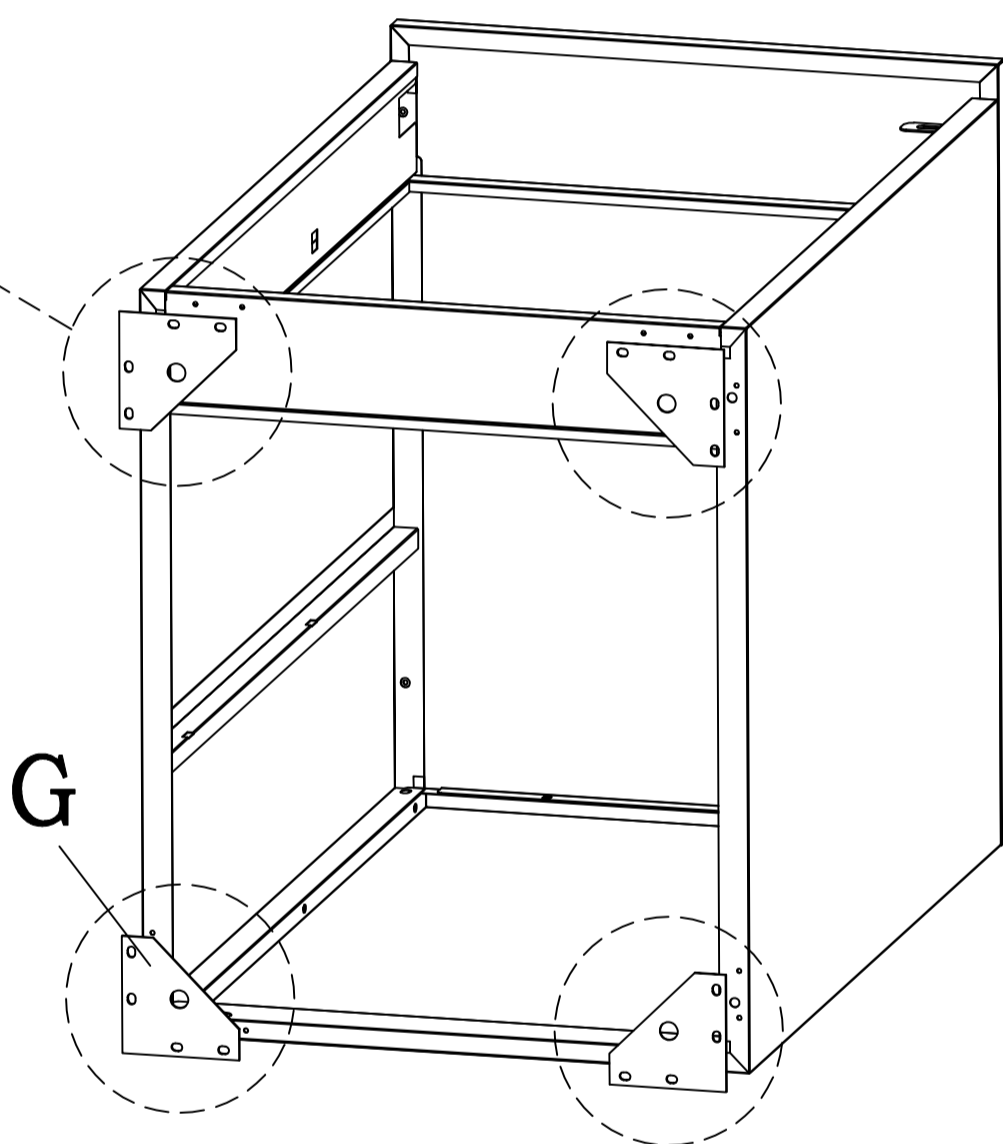
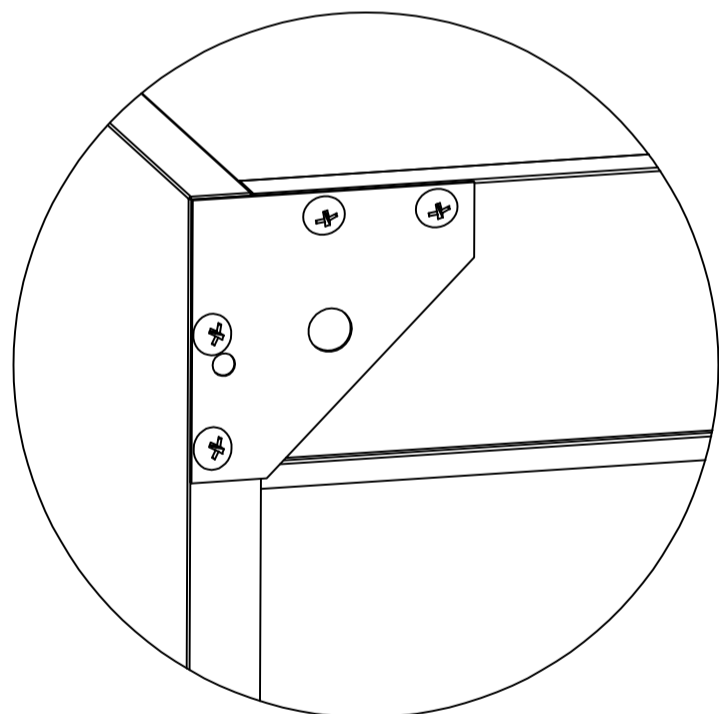
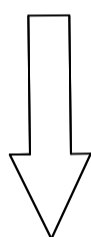
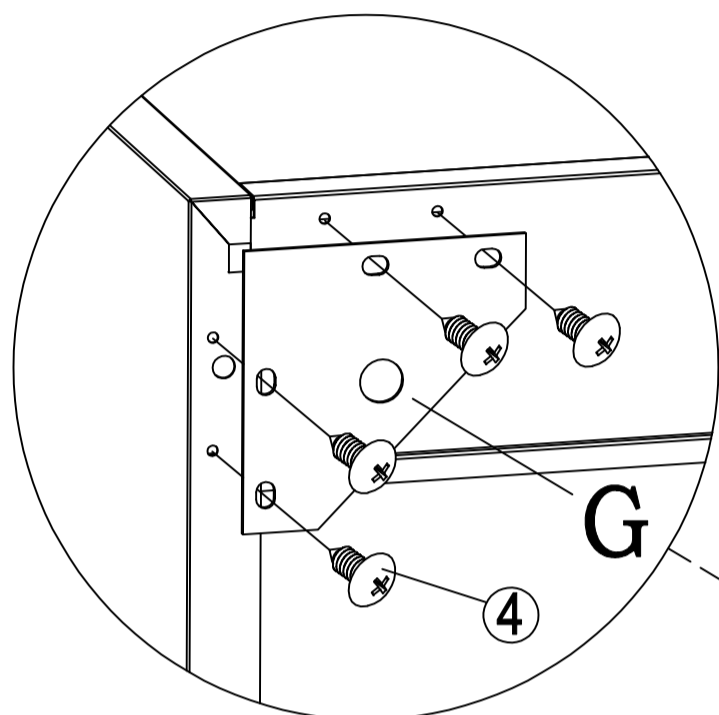

G x4	④ x16
------	-------

6. Assemble G, secure with screw 4.

07

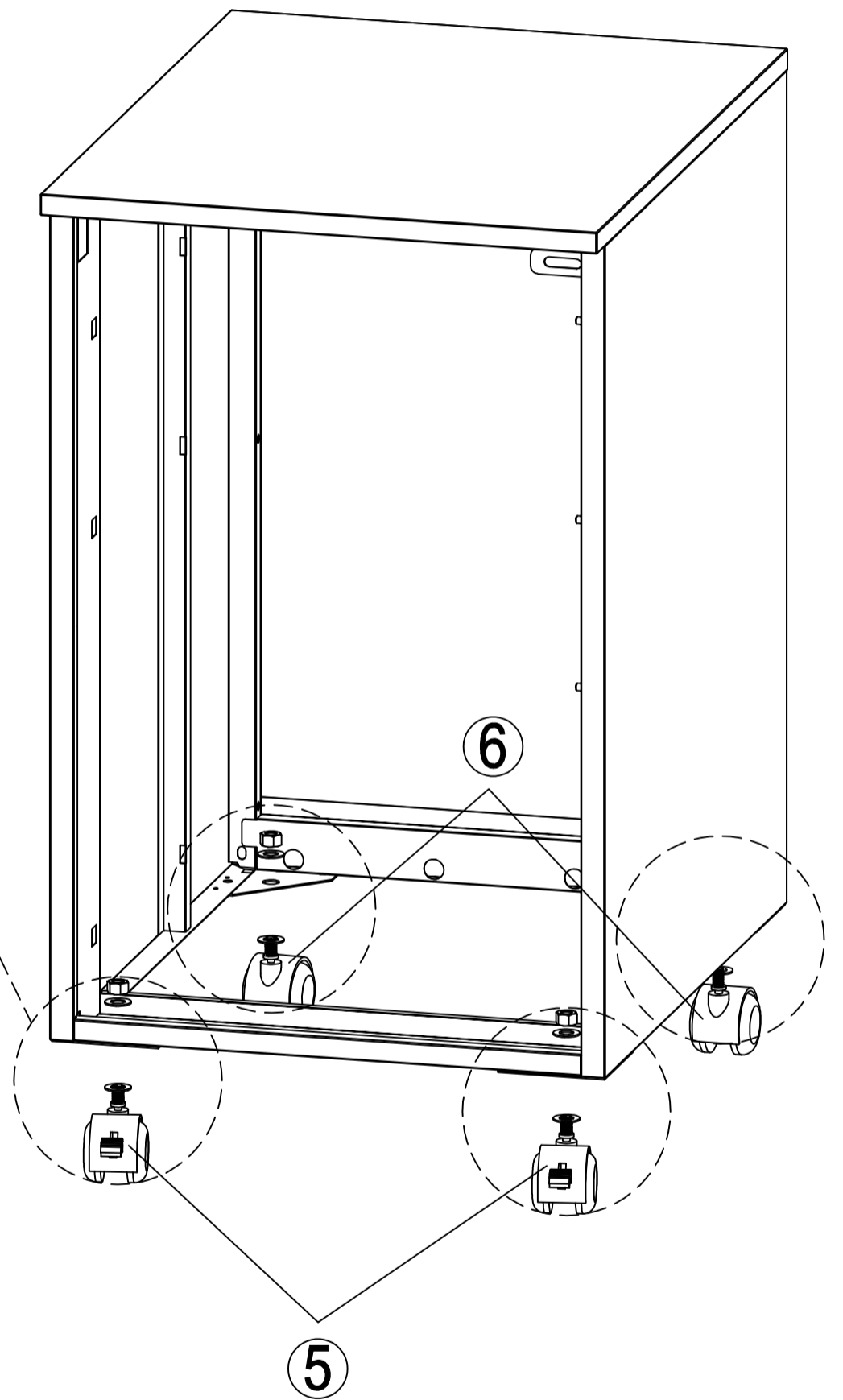
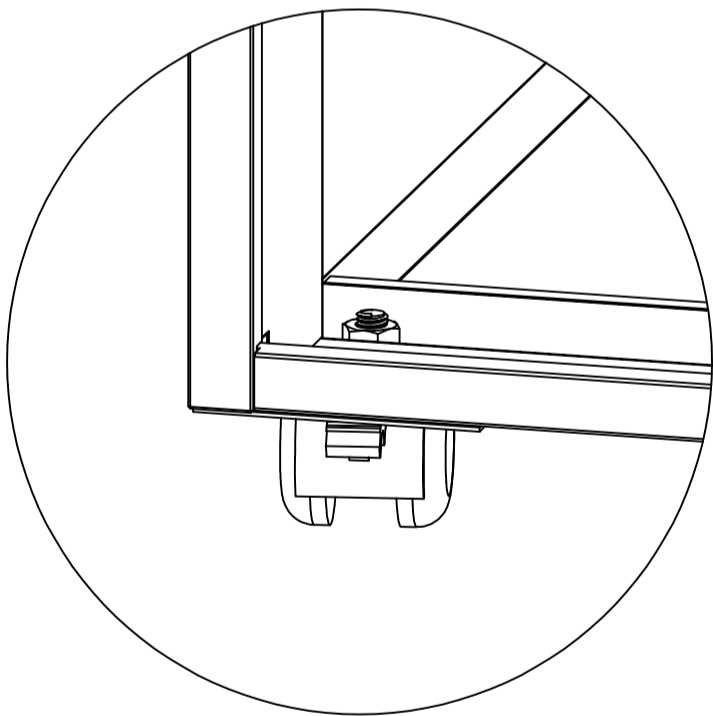
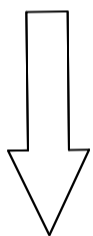
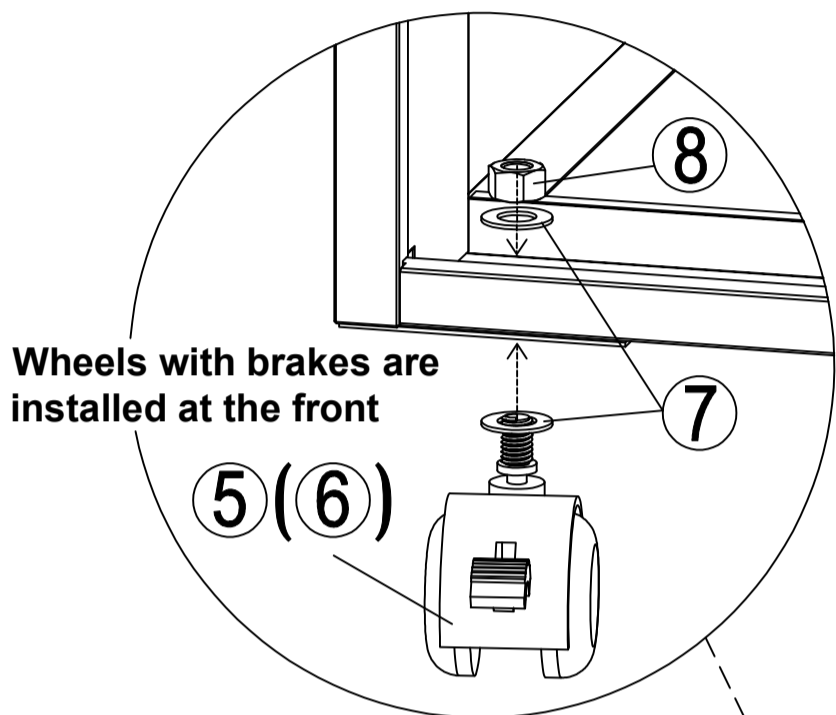

5 x2	6 x2
7 x8	8 x4

7. Assemble 5(6) and 7, fix them with 8.

08

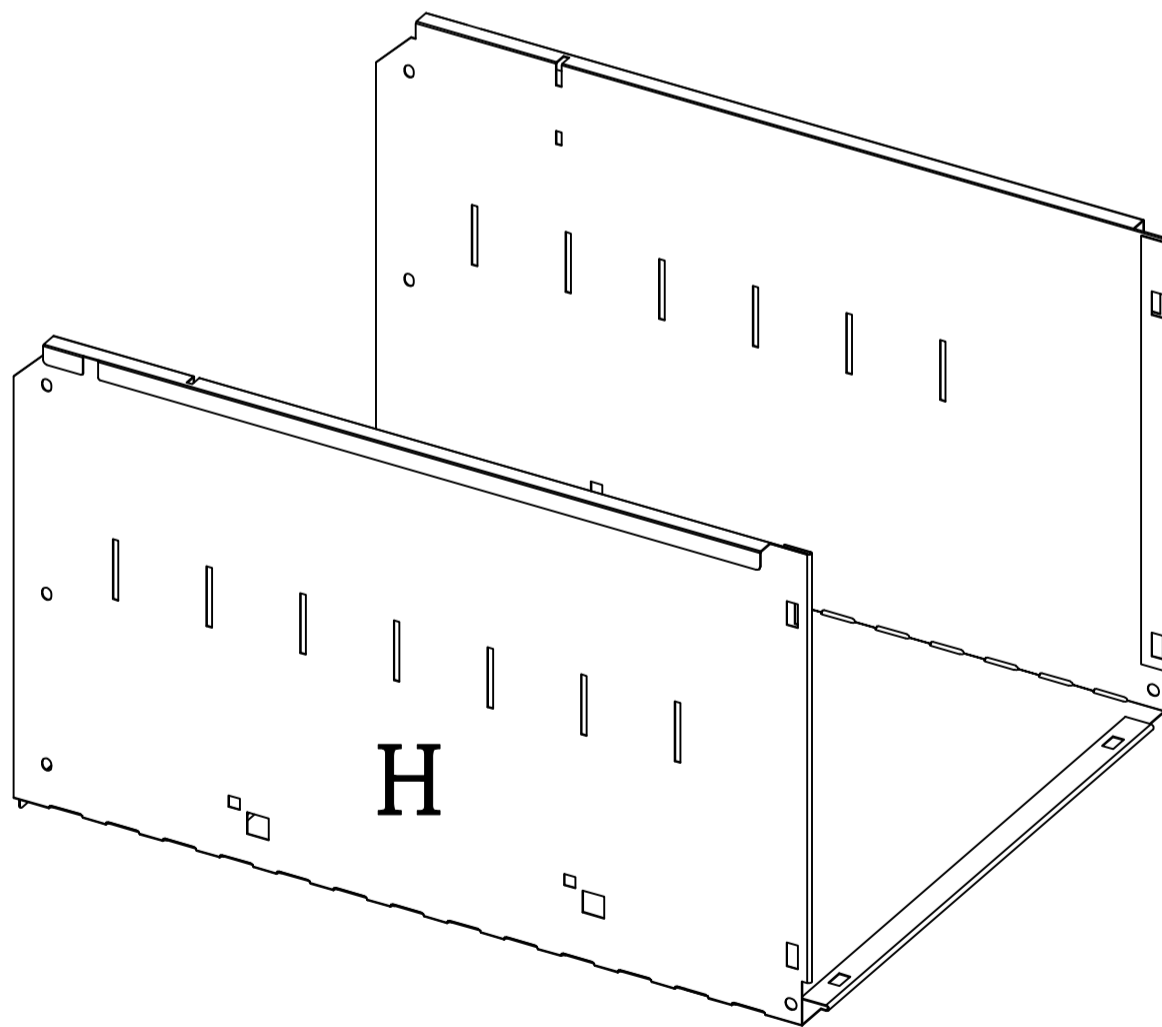
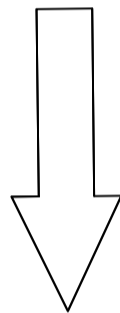
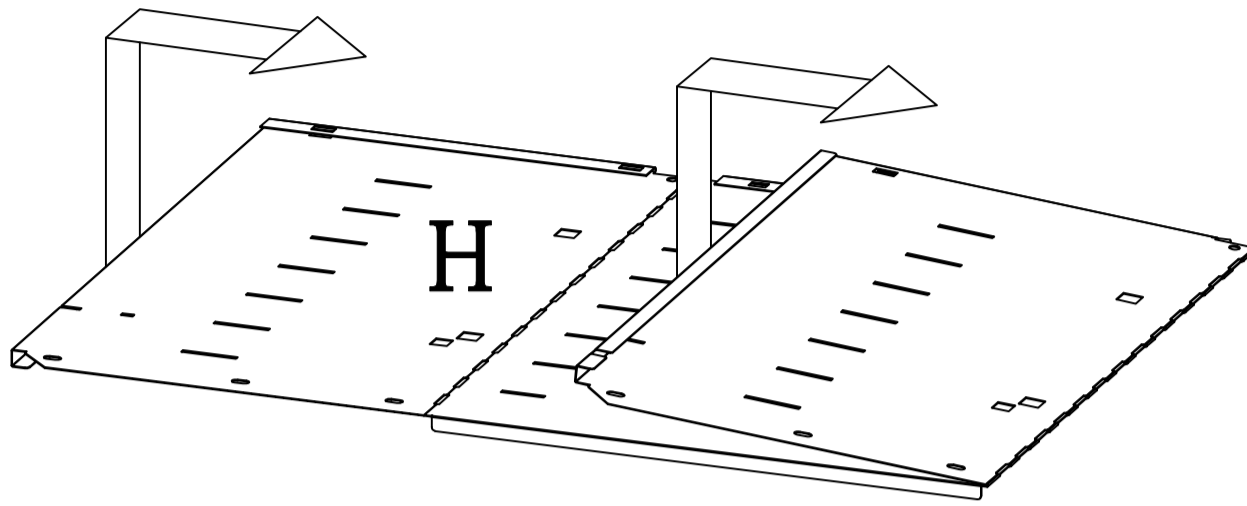

8. Fold H.

09

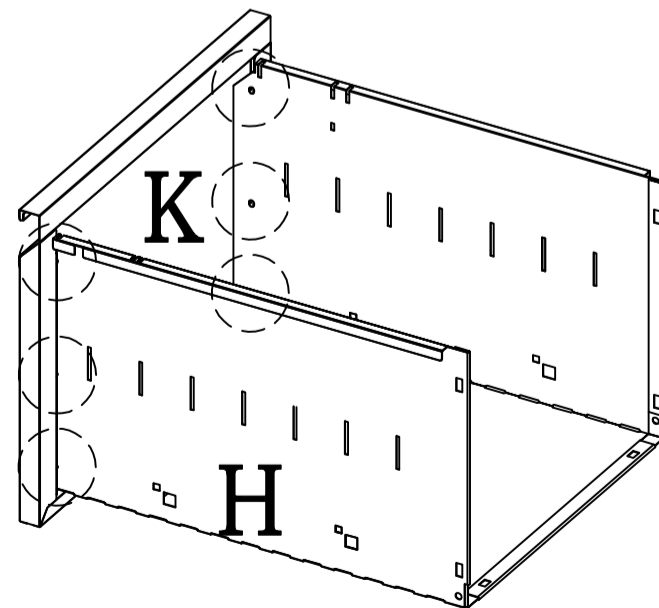
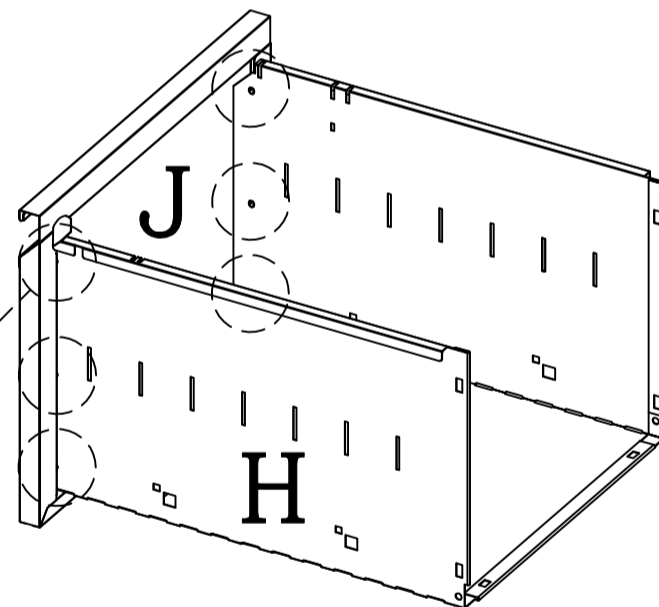
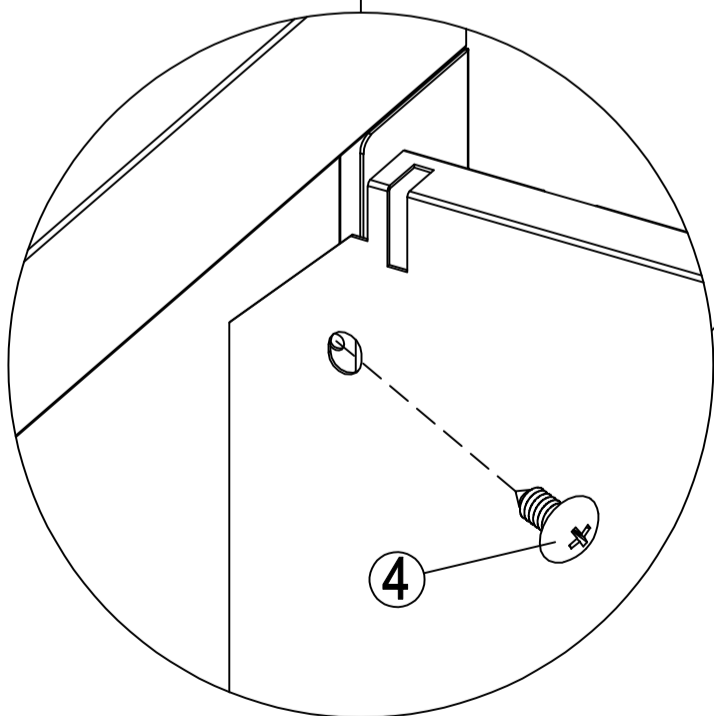
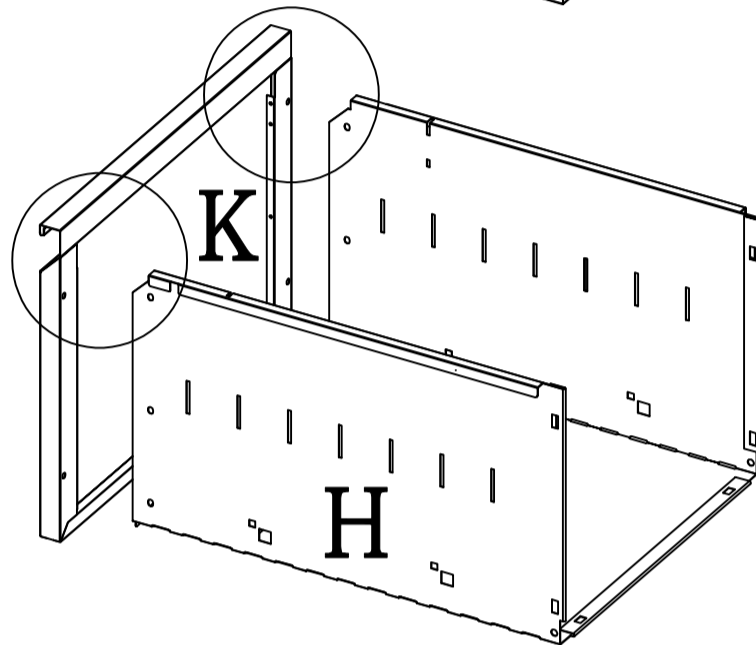
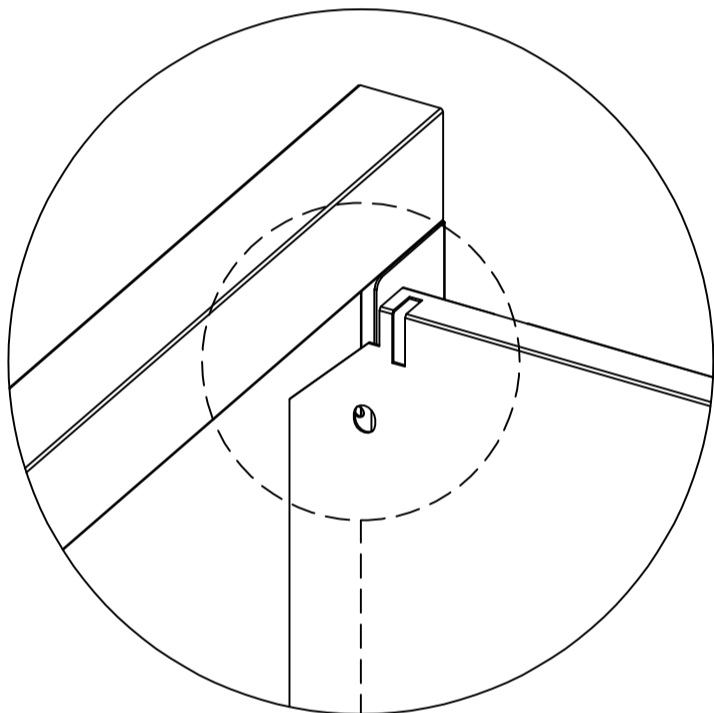
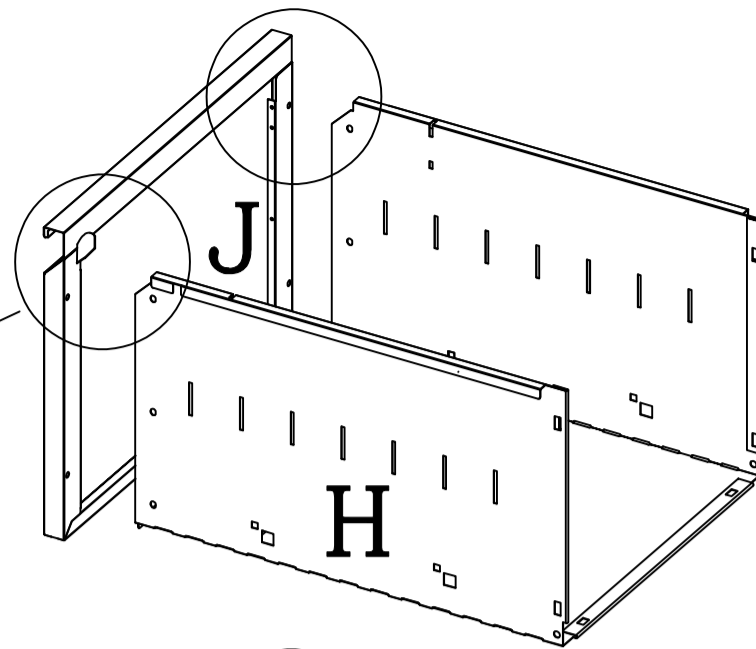
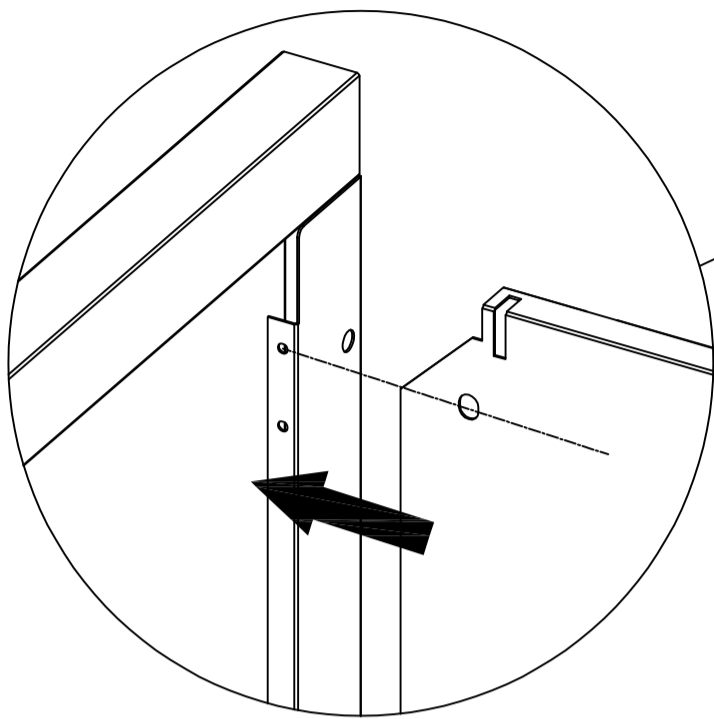

④ x6

9. Assemble H and J (K), secure with screw 4.

10

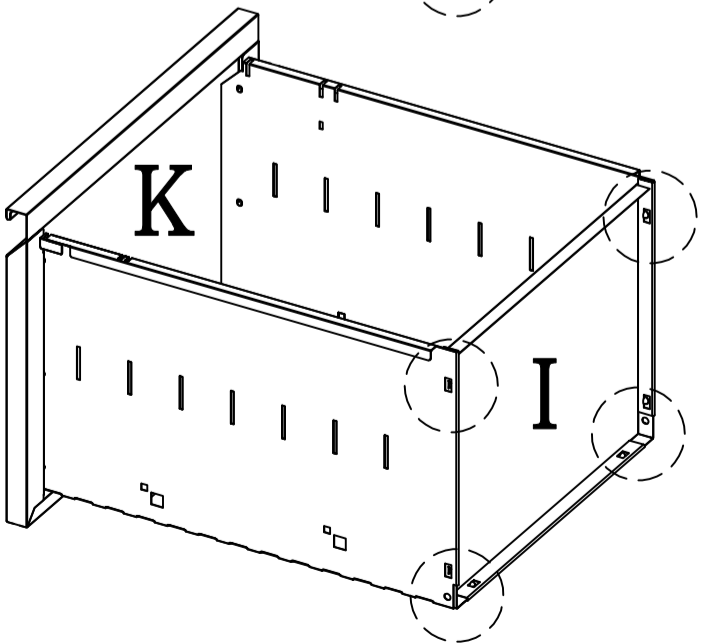
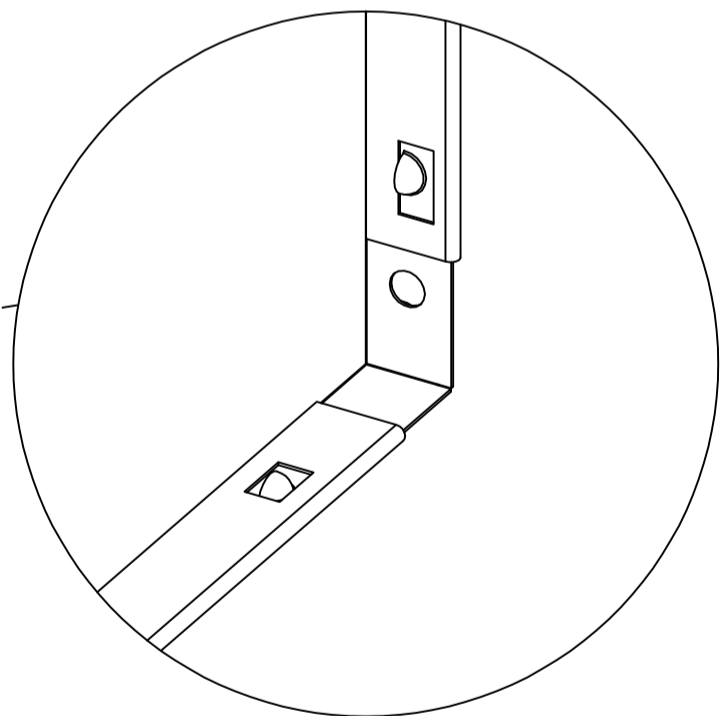
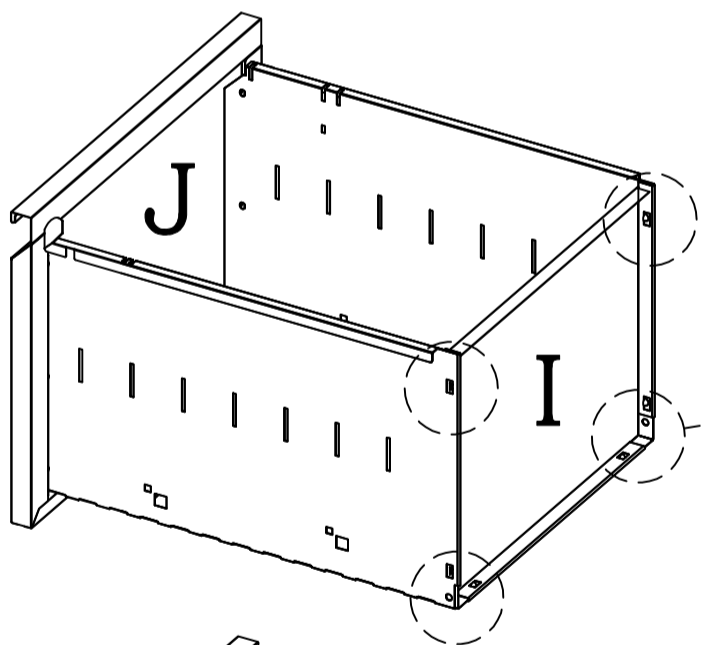
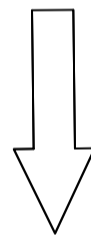
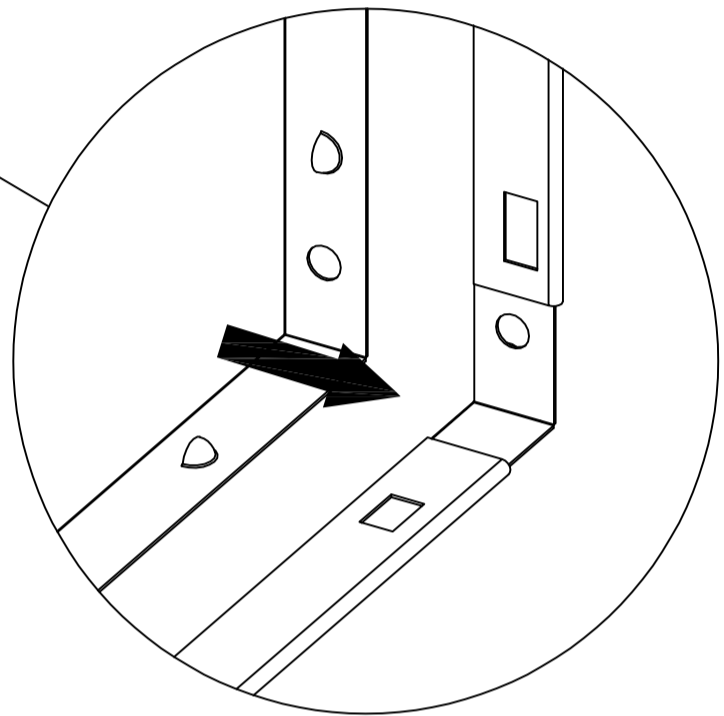
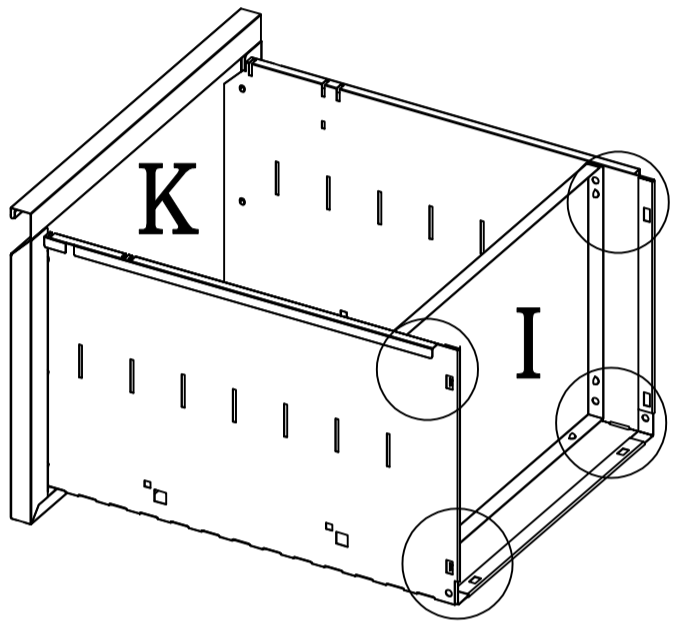
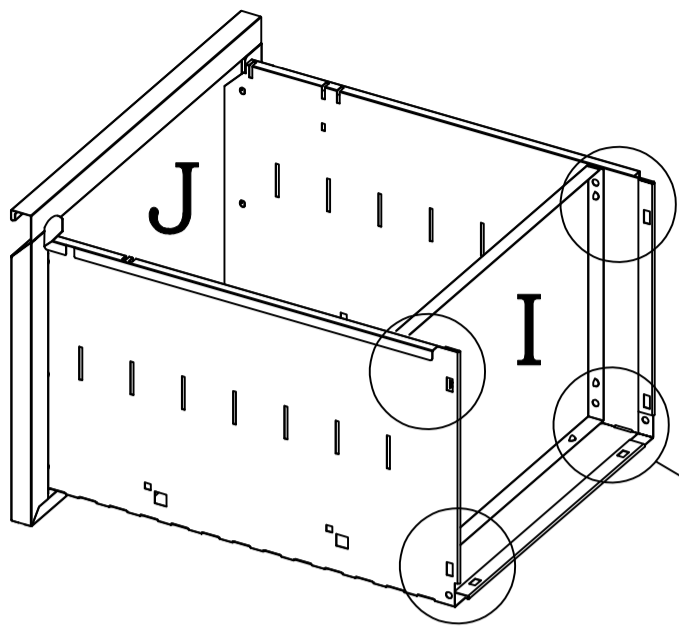

10. Assemble I.

11

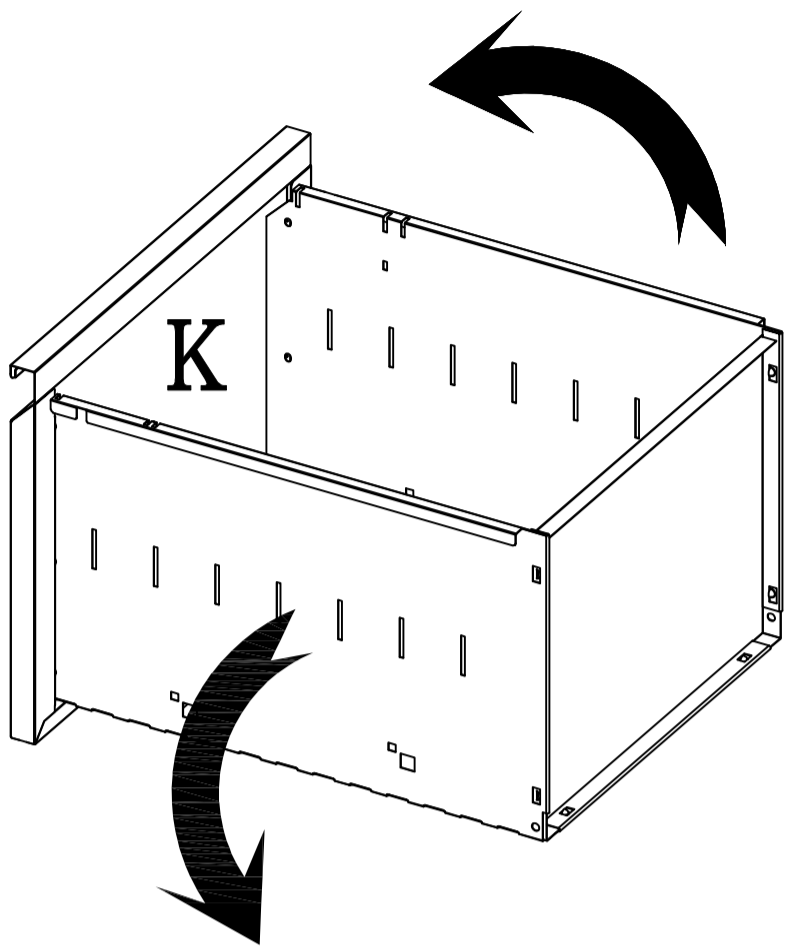

reverse the drawer

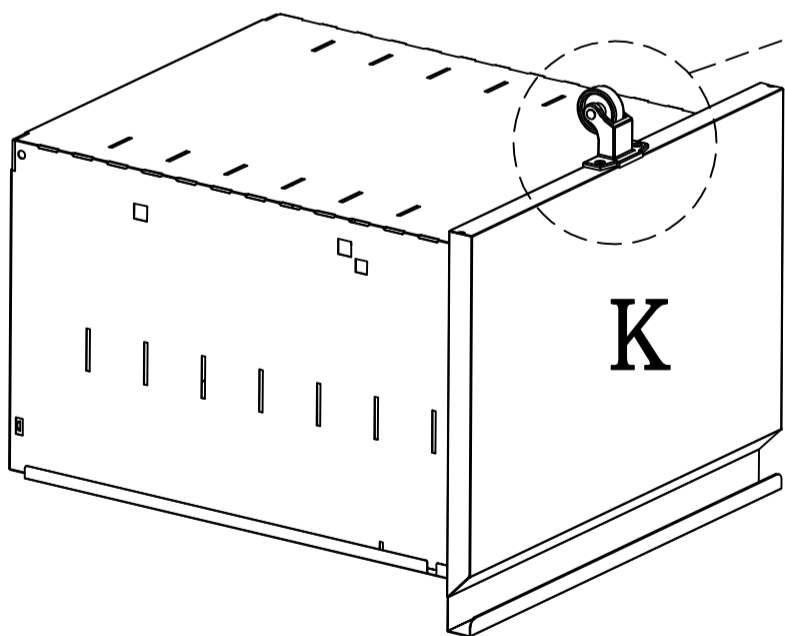
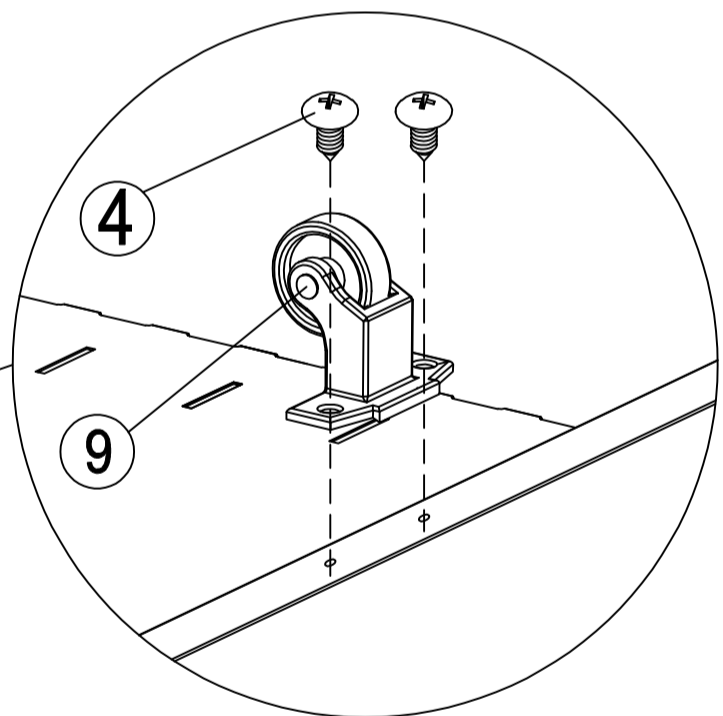
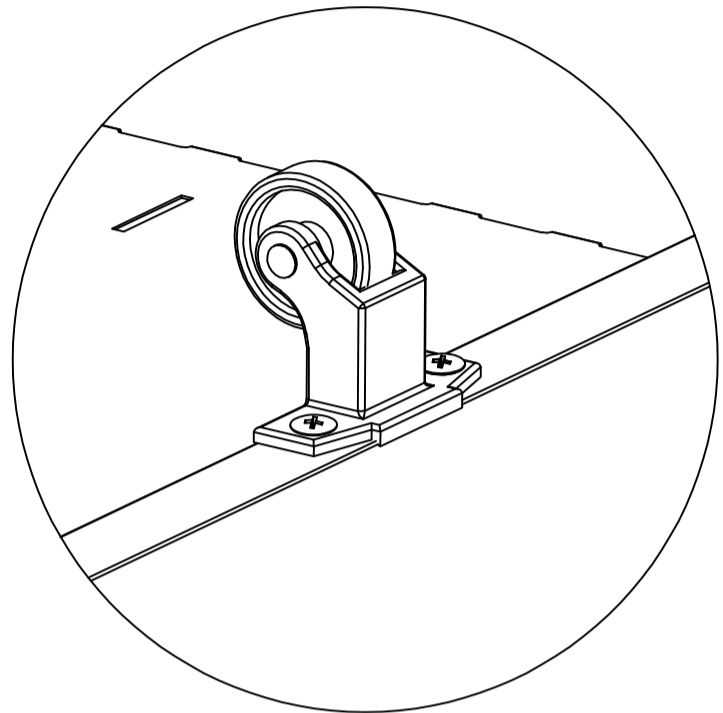

④ x2

⑨ x1

11. Assemble 9, secure with screw 4.

12

1. Press the plastic clips and pull out the slide rails and take out L.2(R.2) from L(R) before assembling.

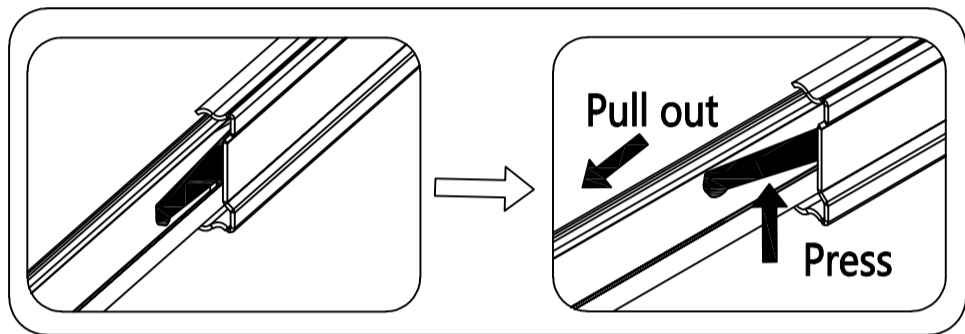
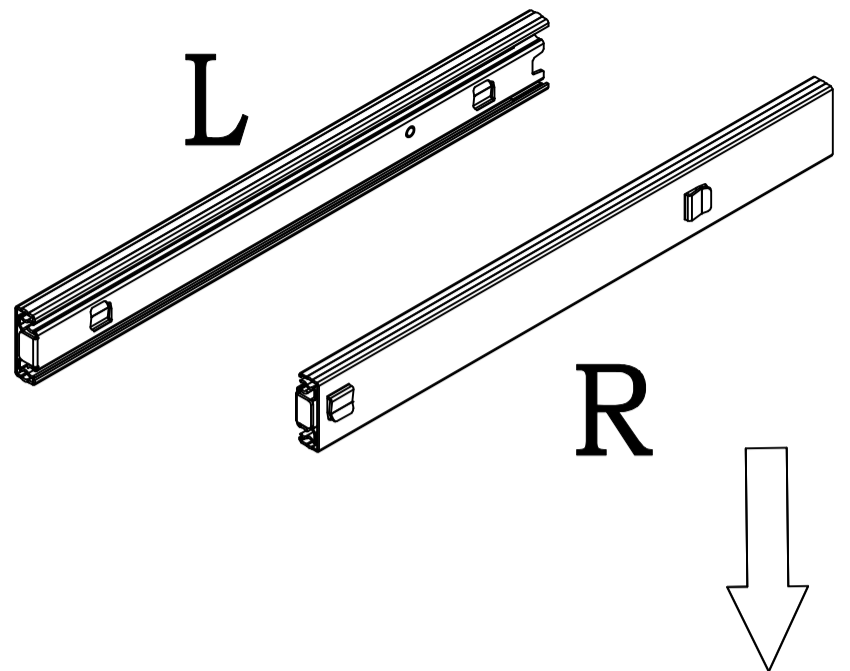

2. Please grip the L(R) part while sliding L.2(R.2) part.

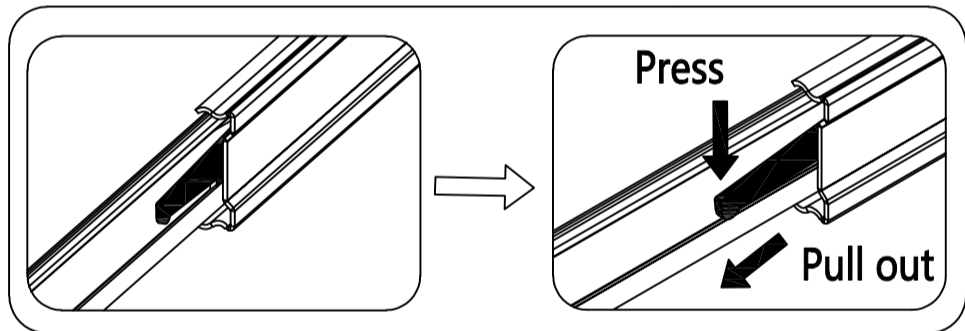

3. Accomplish.

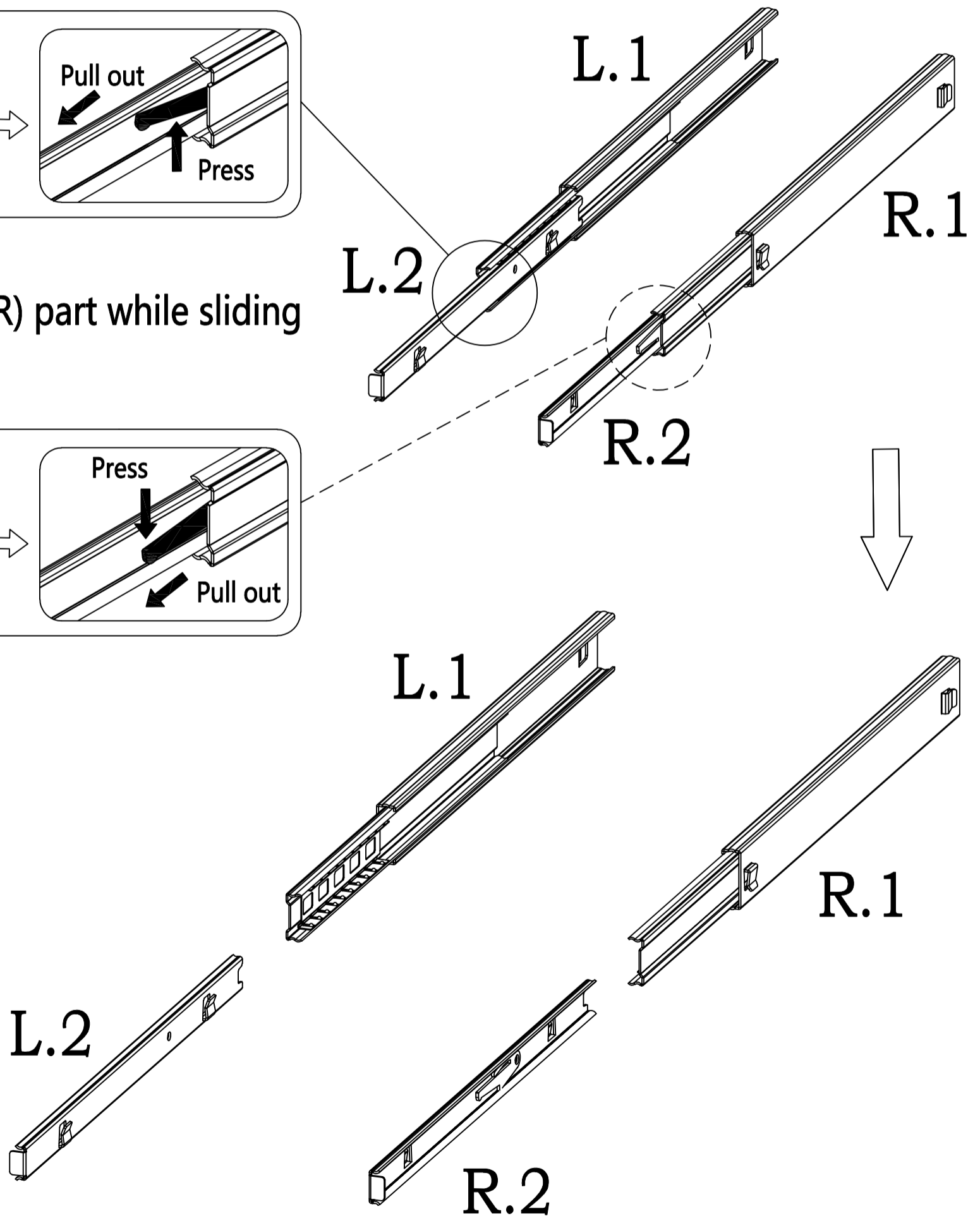

12. Split L(R) into L1(R1) and L2(R2).

13

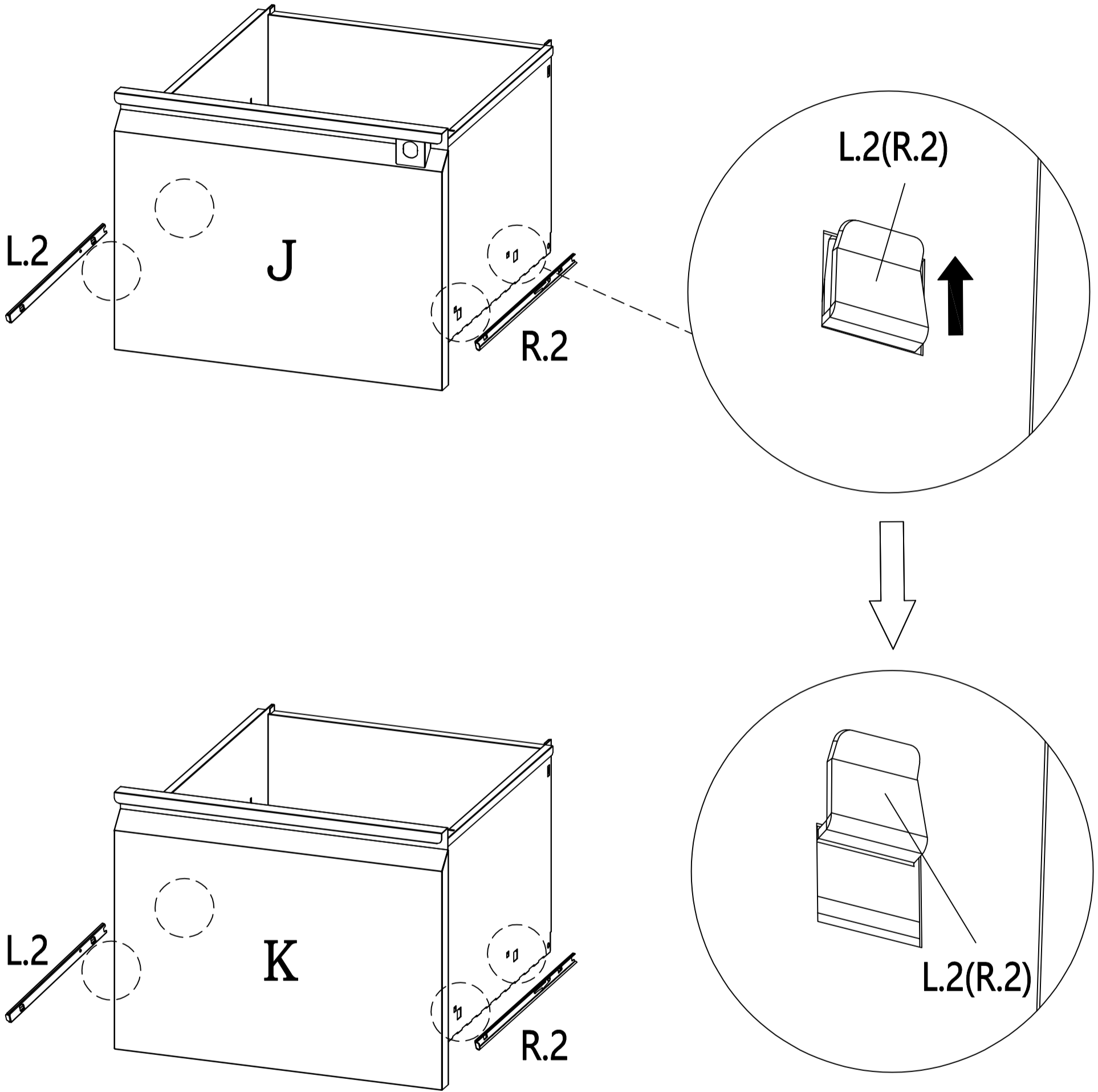

13. Assemble L2(R2).

14

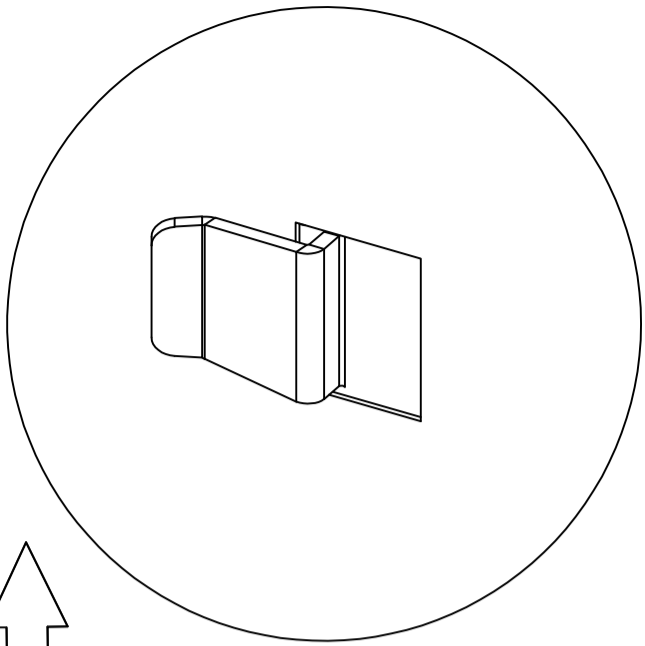

First install the tail end of L1(R1), then install the front end of L1(R1).

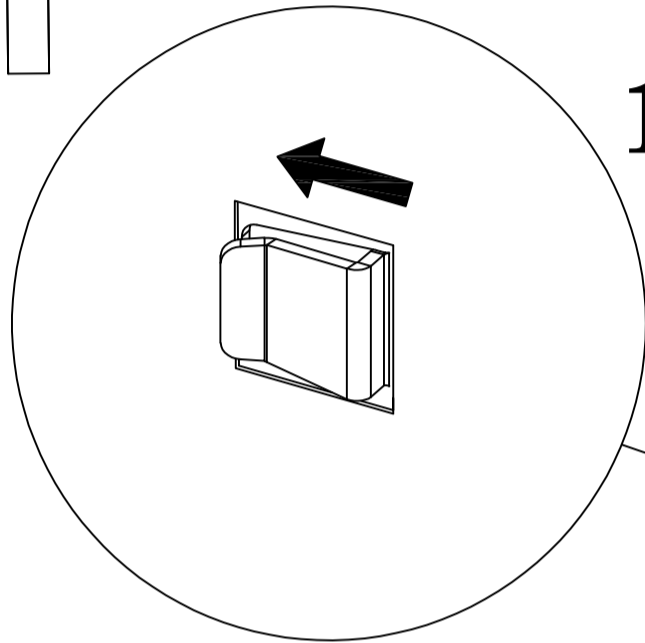
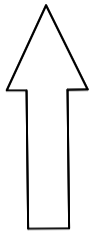

1st

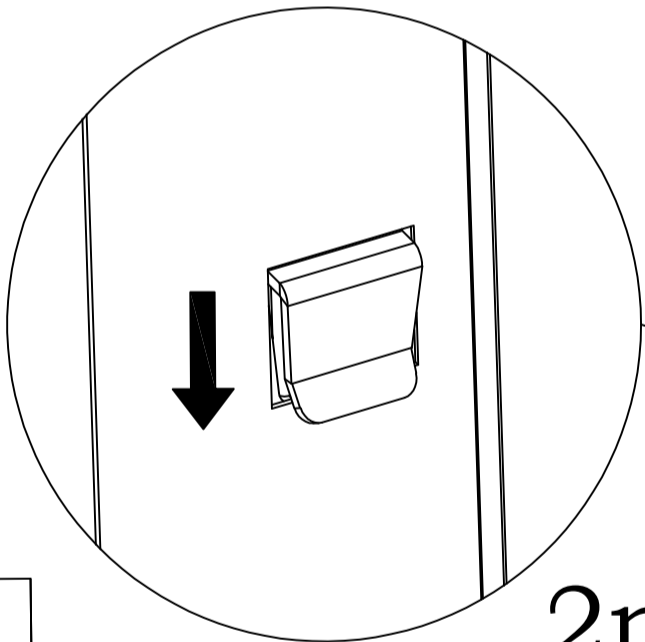

2nd

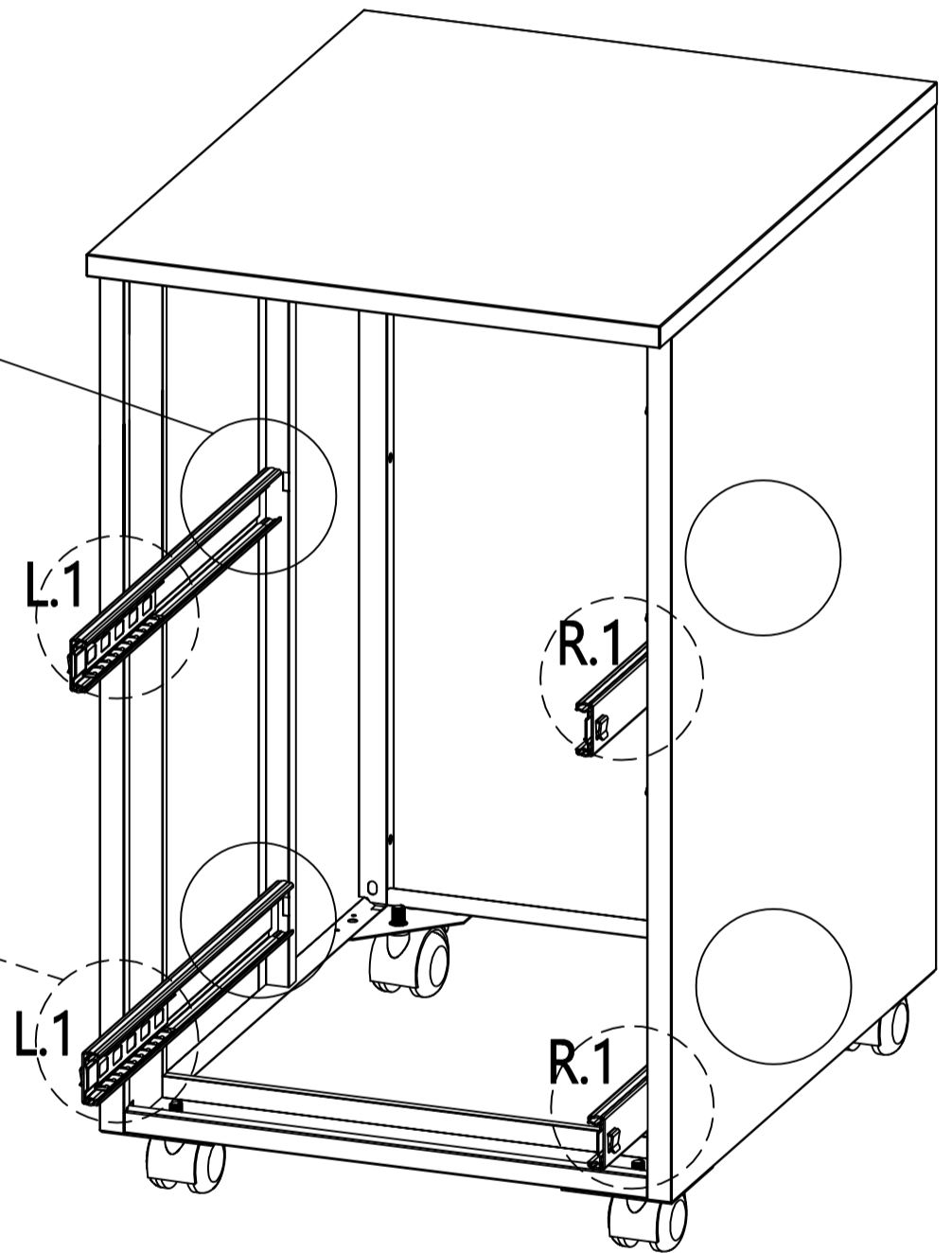
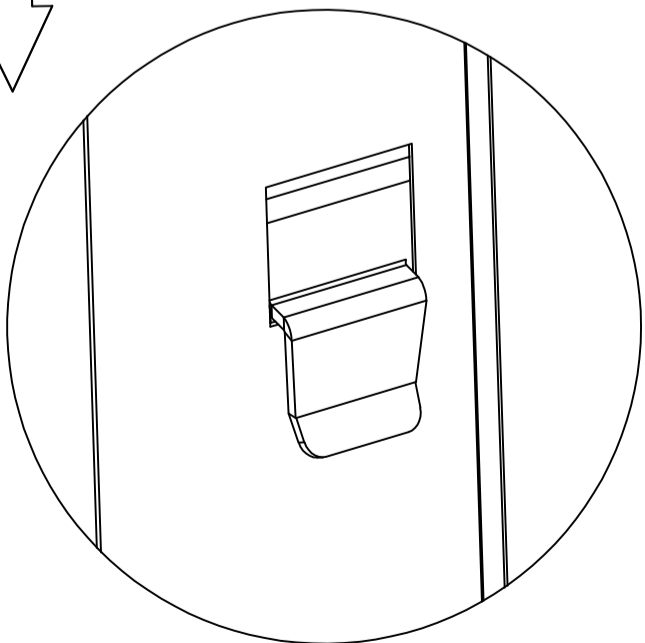
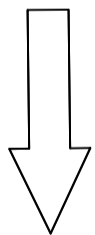

15

1. Please full extend the slide runners.

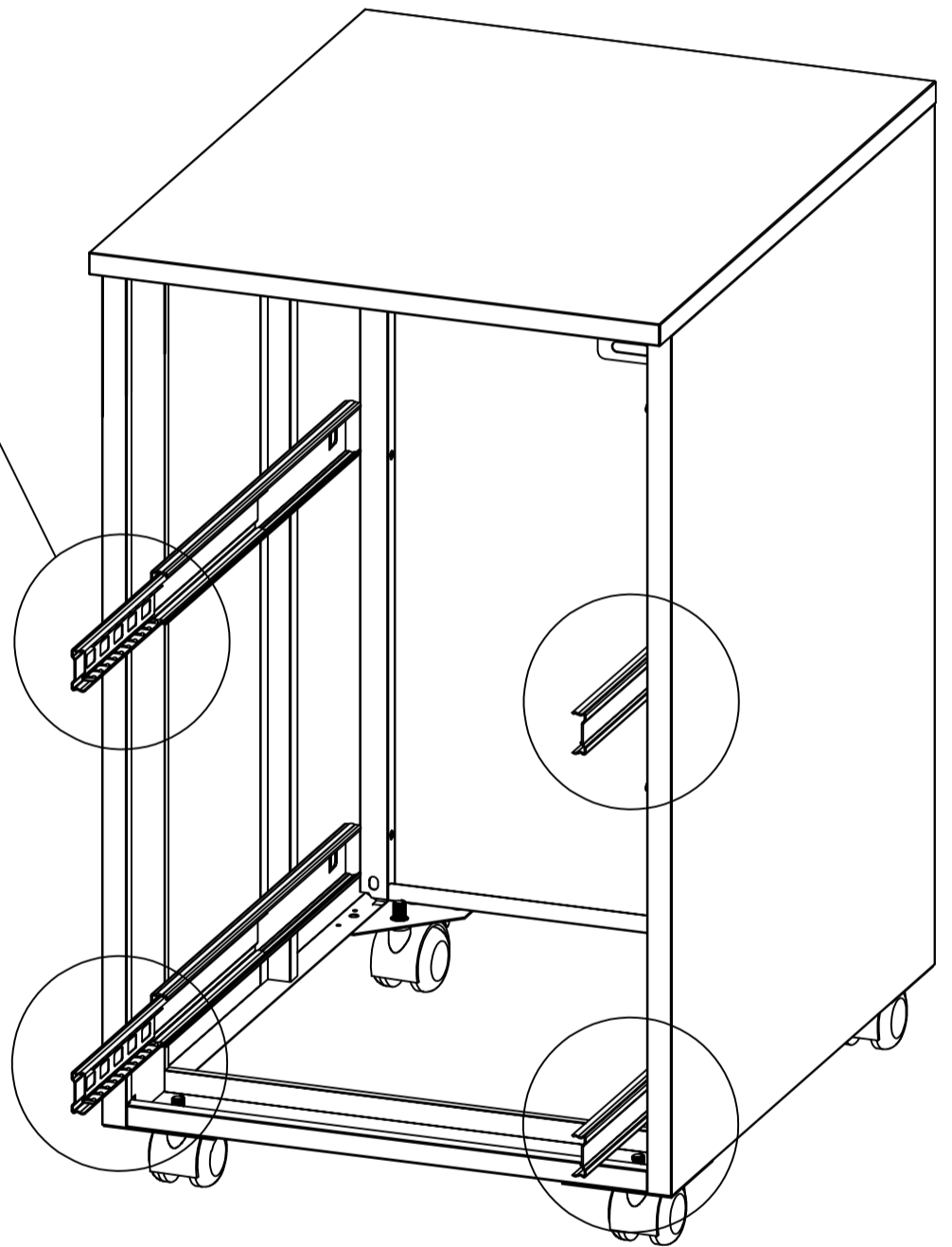
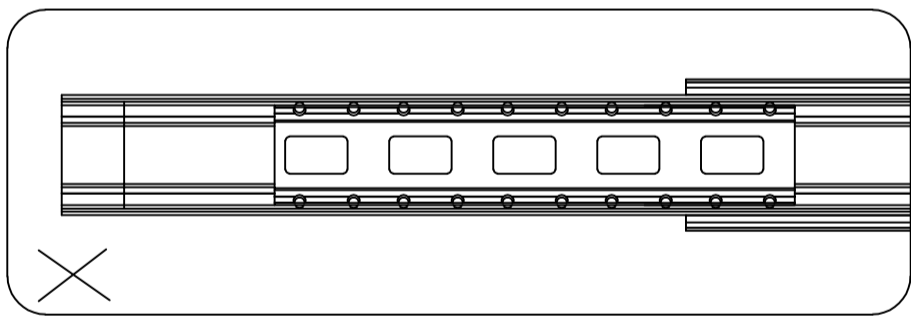
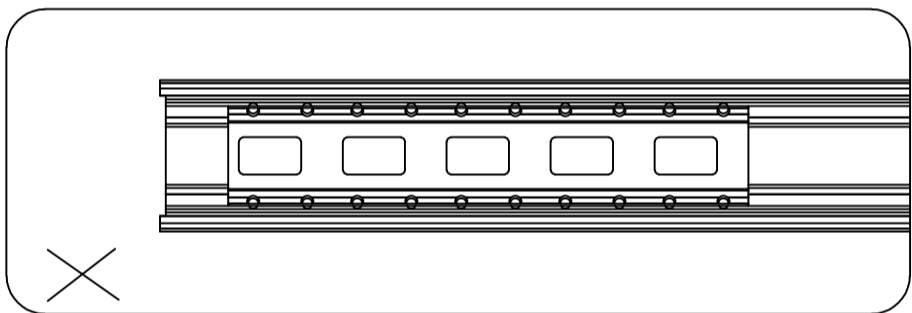
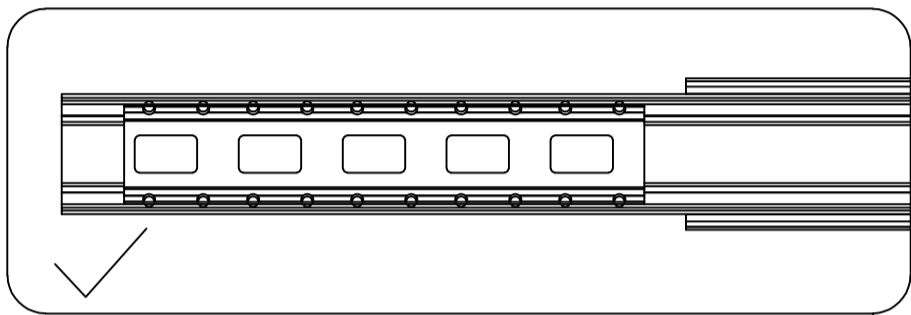

2. Push the ball bearing cart all the way to the end of the slide(in both sides).

15. Please full extend the slide runners.

16

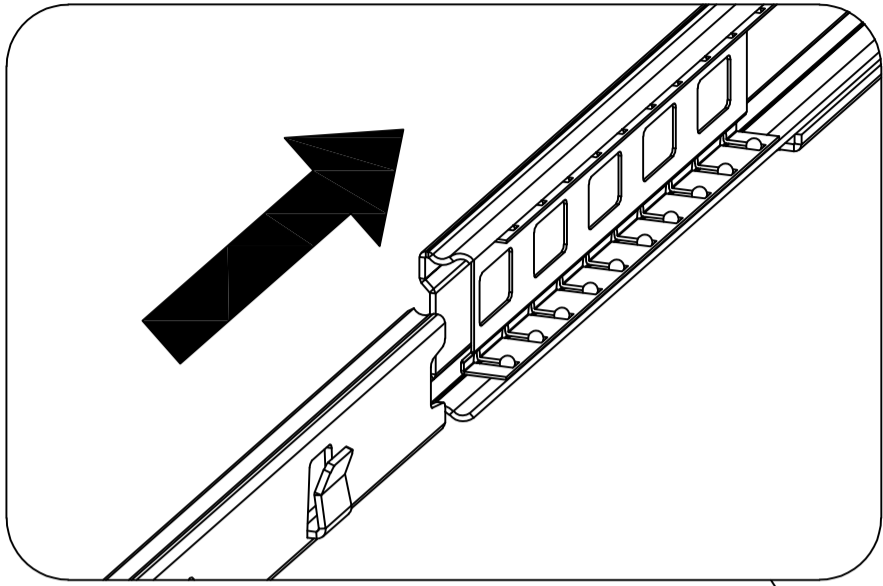

3. Align the slide runners on the drawer with the unit and push it carefully inside until it stops.

! If the drawer does not go in smoothly please take it out and repeat the step.

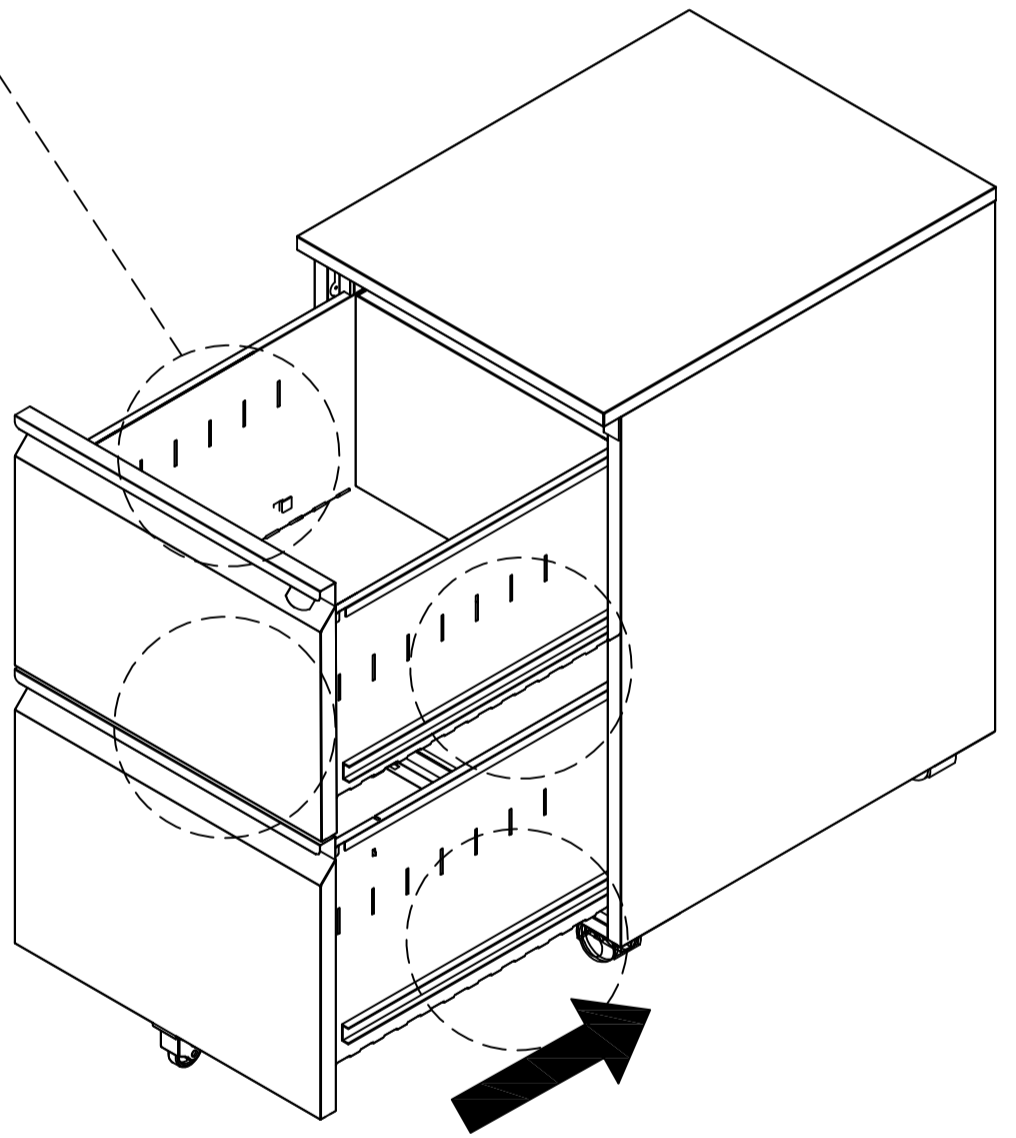
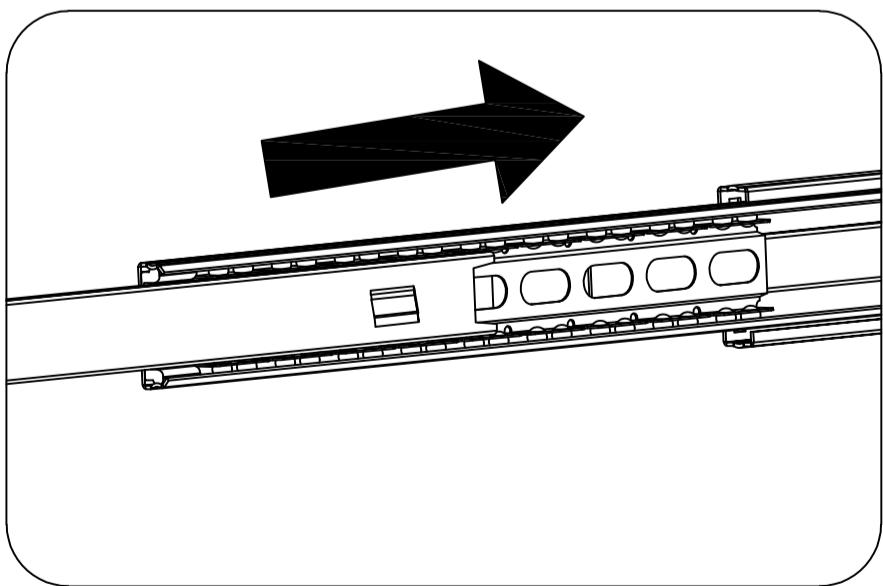
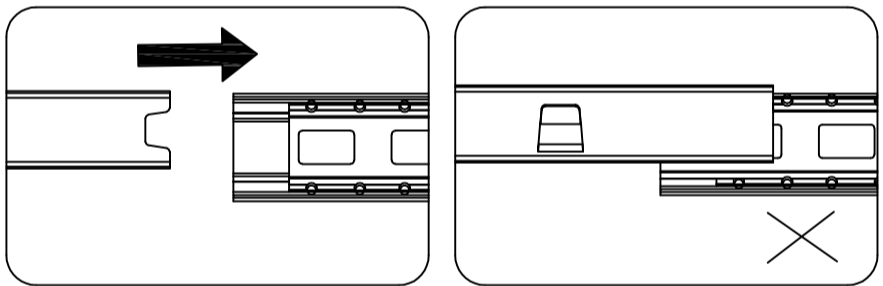
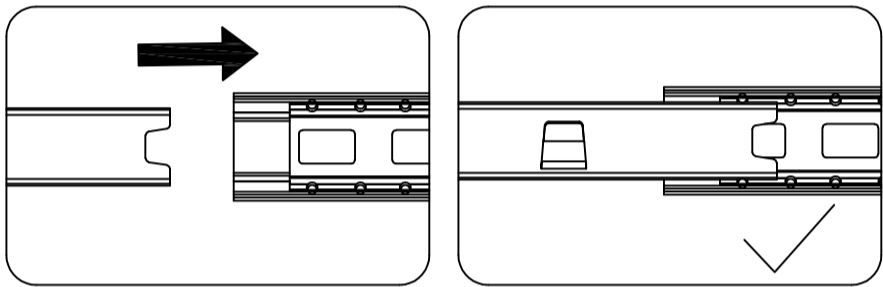

16. Assemble the drawers.

17

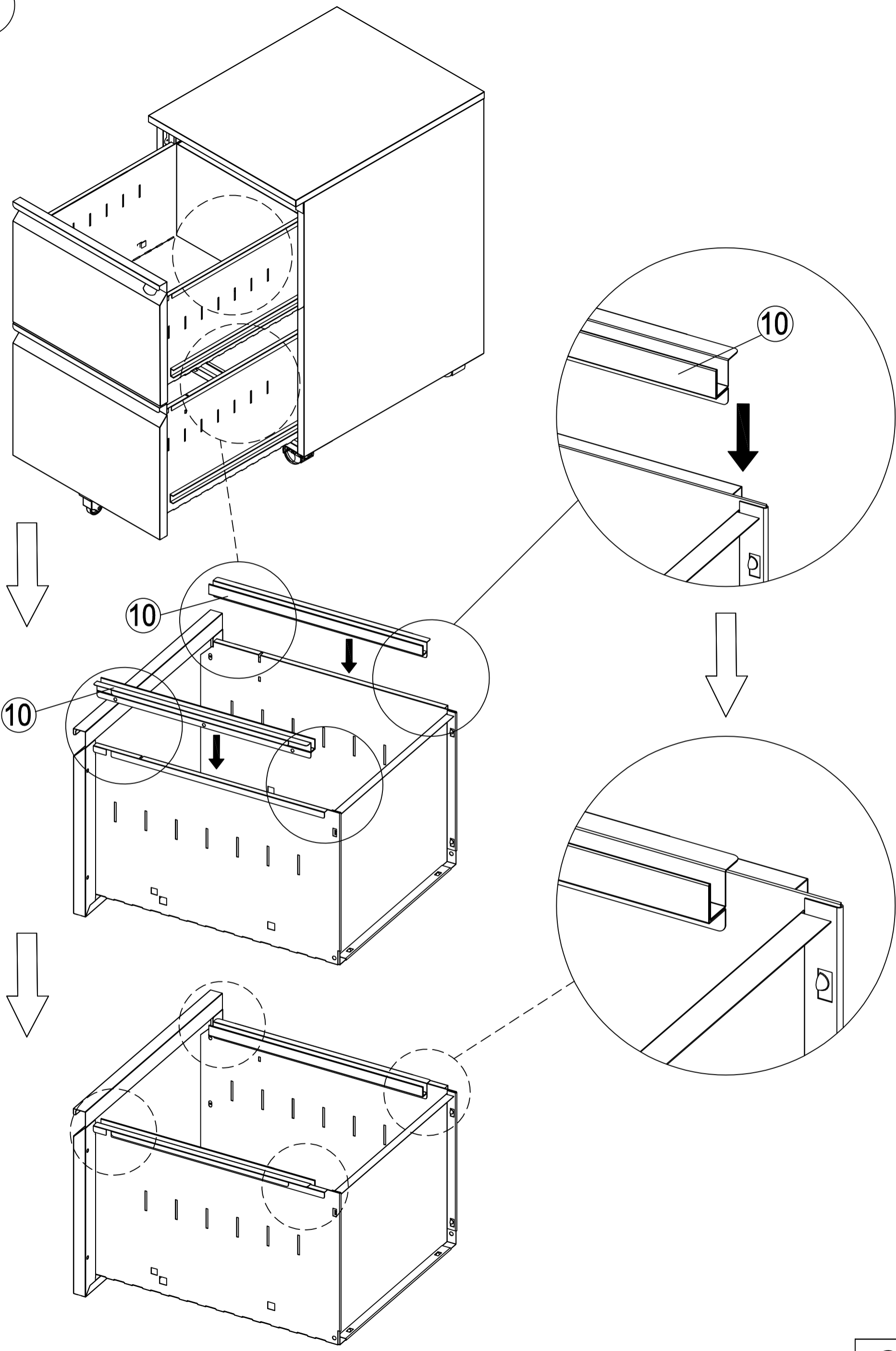

⑩ x4

17. Assemble 10 on both drawers.

18

With the lock logo facing upwards, adjust the lock lever to the bottom.

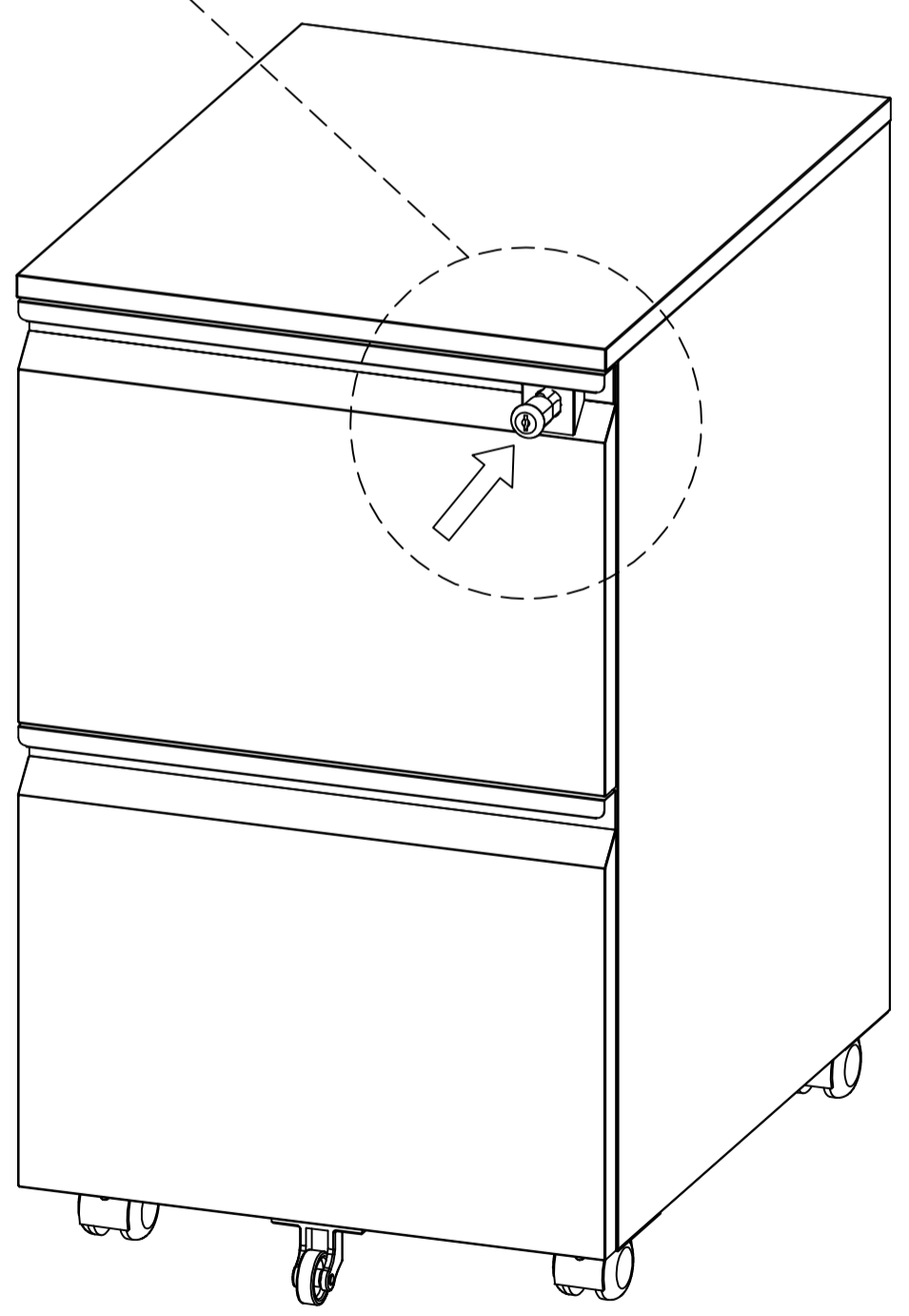
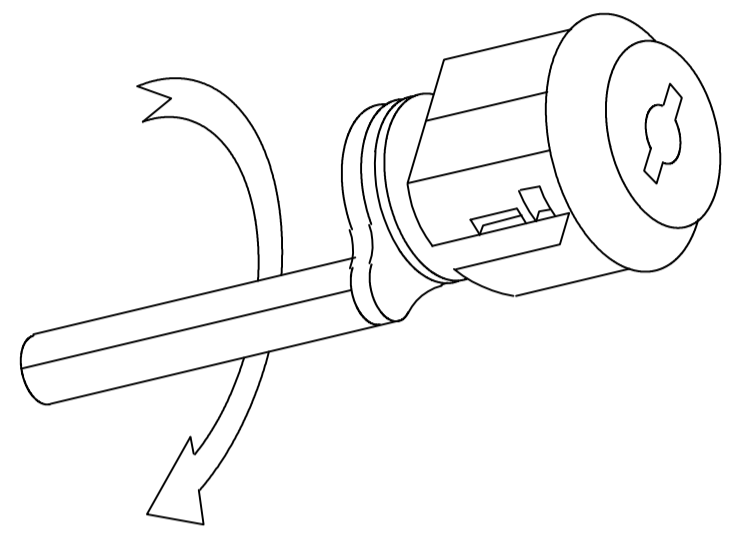
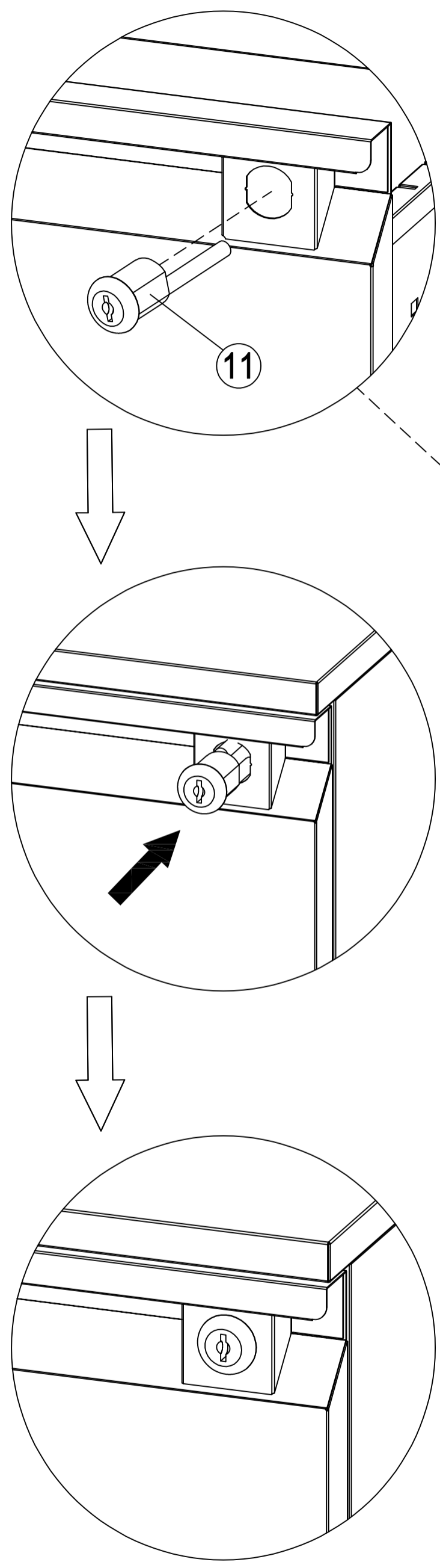

⑪ x4

18. Assemble 11.