

ROTO-Q 360 Basic Set – What's Inside

Box 1

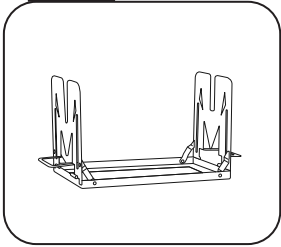

Collapsible Cooking Frame
The main frame that unfolds into shape

Box 2

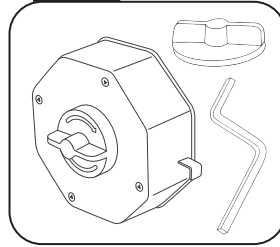

Power Core + Knob + Crank
Wind-up core that powers the rotisserie

Box 3

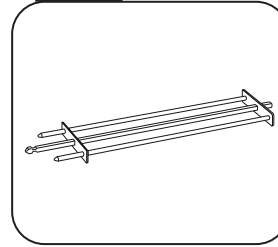

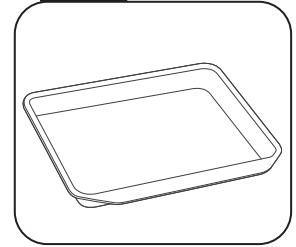

3-Prong Spit
Holds your food and connects to the Power Core

Box 4

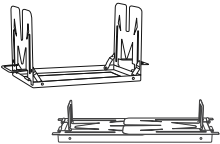

Drip Tray
Catches any drippings; slides into the base of the frame

Assembly Instructions

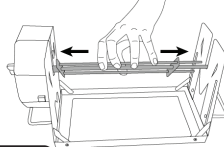
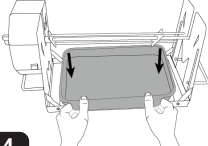
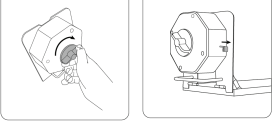
 <p>Step 1</p>	 <p>Step 2</p>	 <p>Step 3</p>	 <p>Step 4</p>	 <p>Step 5</p>
<p>Unfold the Cooking Frame</p> <p>-Open Box 1 and expand the collapsible frame fully</p>	<p>Attach the Power Core to the Frame (3 holes)</p> <p>-Attach the Power Core from Box 2 to the right side of the frame using the 3 holes. No screws needed.</p>	<p>Insert the 3-Prong Spit</p> <p>-Slide the 3-Prong Spit into the Power Core. -Secure the opposite end into the opposite frame wall.</p>	<p>Place the Drip Tray</p> <p>-Slide the tray into the base opening.</p>	<p>Wind it up</p> <p>-Turn the knob clockwise until it comes to a complete stop -approx. 40 turns = up to 1 hour of cooking time</p>