



LINON HOME DECOR PRODUCTS, INC.

---

## ASSEMBLY INSTRUCTION

STORAGE BENCH SHORT SPLIT SEAT  
BANC COFFRE AU COUVERCLE DIVISÉ  
BANCO BAÚL CON CUBIERTA DIVIDIDA

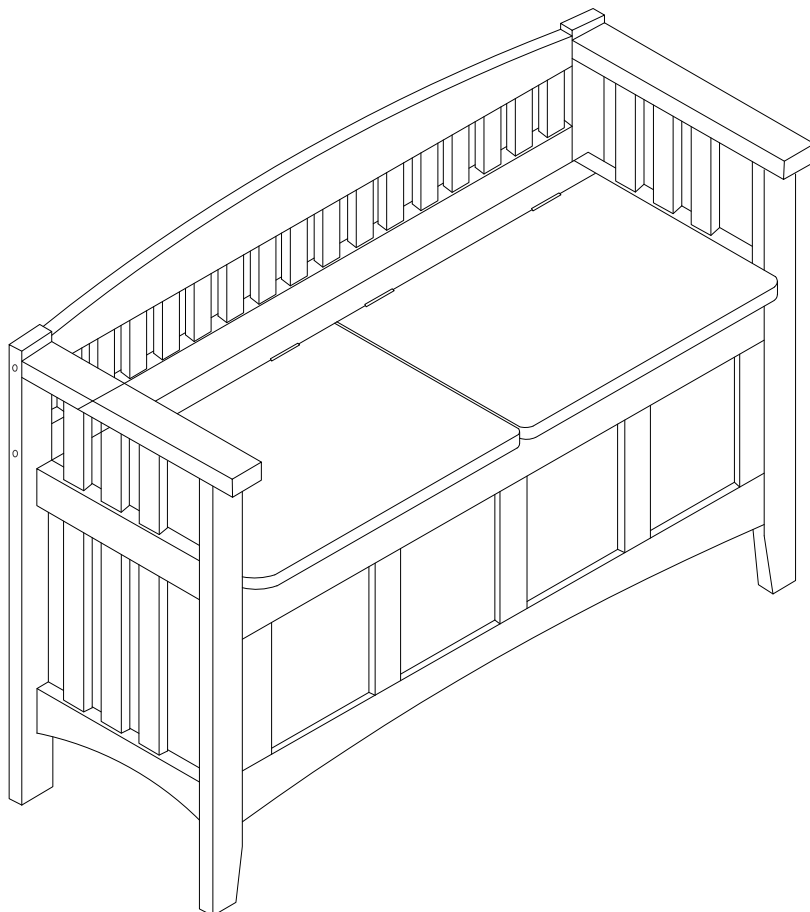

### We are here to help !

We do our best to insure that your furniture arrives in excellent condition. In the event that a part is damaged or missing, Linon Home Decor will be happy to provide you with replacement parts, at no charge, within 30 days of purchase, providing the parts are available in our warehouse and the item purchased is part of our current inventory. In order to receive spare parts, at no charge, you must provide proof of purchase within 30 days.

If you need assistance with assembly or replacement parts, please call Lion Customer Service, prior to returning the item to the store.

Our office is open Monday- Friday 9AM-5PM, Eastern Standard Time.

Our toll free customer service number is: 1-800-262-1852.

Or visit our web site [WWW.LINON.COM](http://WWW.LINON.COM) to order spare parts and for care instructions on your newly purchased furniture.



PART IDENTIFICATION:

PARTS	DESCRIPTION	QTY
#1	LEFT SIDE FRAME	01
#2	RIGHT SIDE FRAME	01
#3	BACK PANEL	01
#4	FRONT PANEL	01
#5	BOTTOM PANEL	01
#6	BACKREST	01
#7	SEAT PANEL-LEFT	01
#8	SEAT PANEL-RIGHT	01
#9	SEAT RAIL	01
#10	SUPPORT BRACKET	01

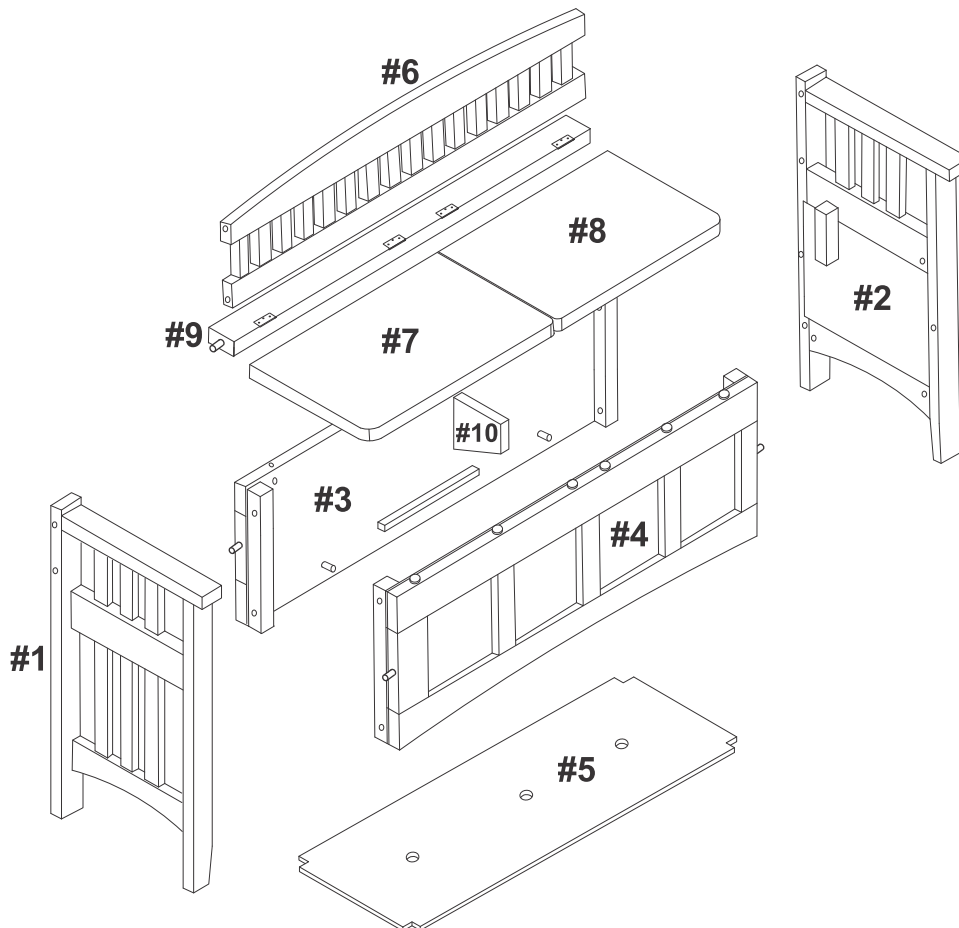



**HARDWARE IDENTIFICATION:**

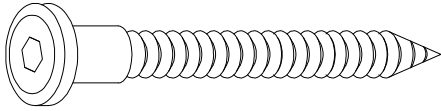

**A x 04**  
**(Ø1/4" x 2-15/16"L)**

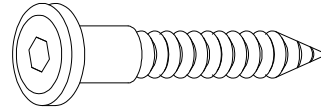

**B x 12**  
**(Ø1/4" x 1-1/4"L)**

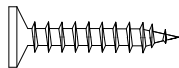

**C x 12**  
**(Ø1/8 x 5/8"L)**

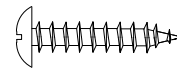

**D x 08**  
**(Ø1/8 x 5/8"L)**

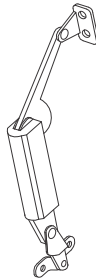

**E x 01**  
**(Left Lid Support)**

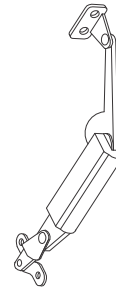

**F x 01**  
**(Right Lid Support)**



**G x 04**  
**(Wood Plug)**



**H x 01**  
**(Allen Key)**





**I x ScrewDriver**  
**(Not Provided)**



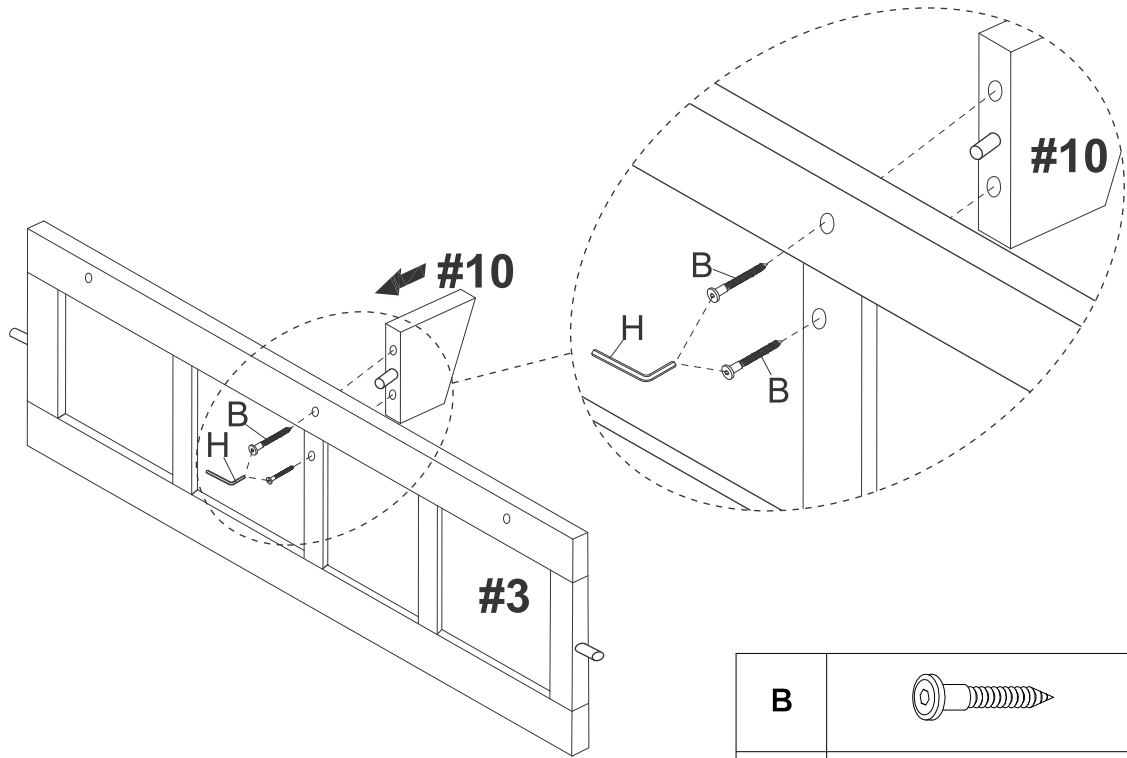

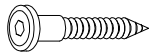
1.

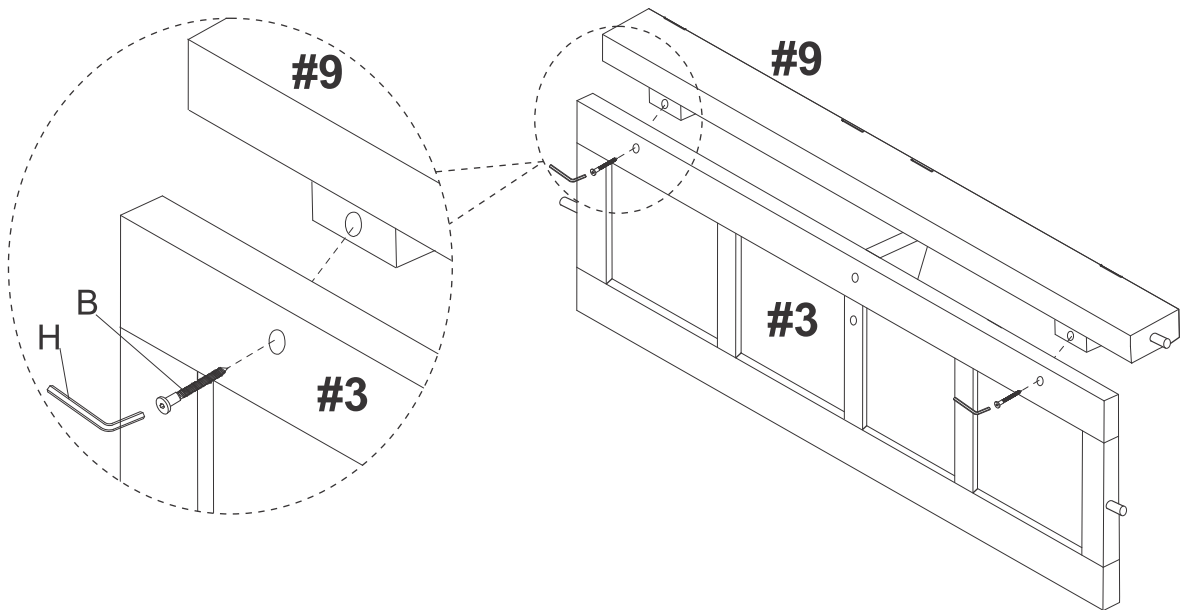

B		02
H		01

2.

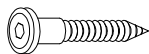



B		02
H		01



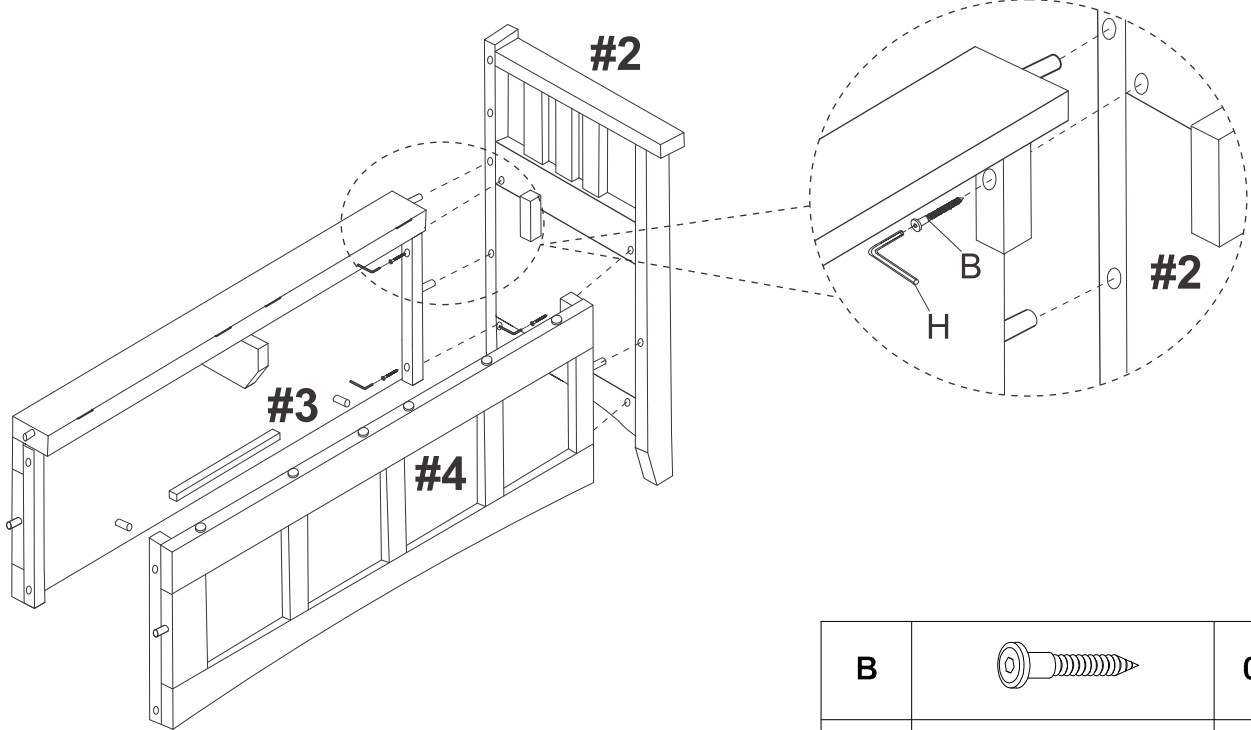

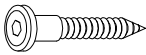
3.

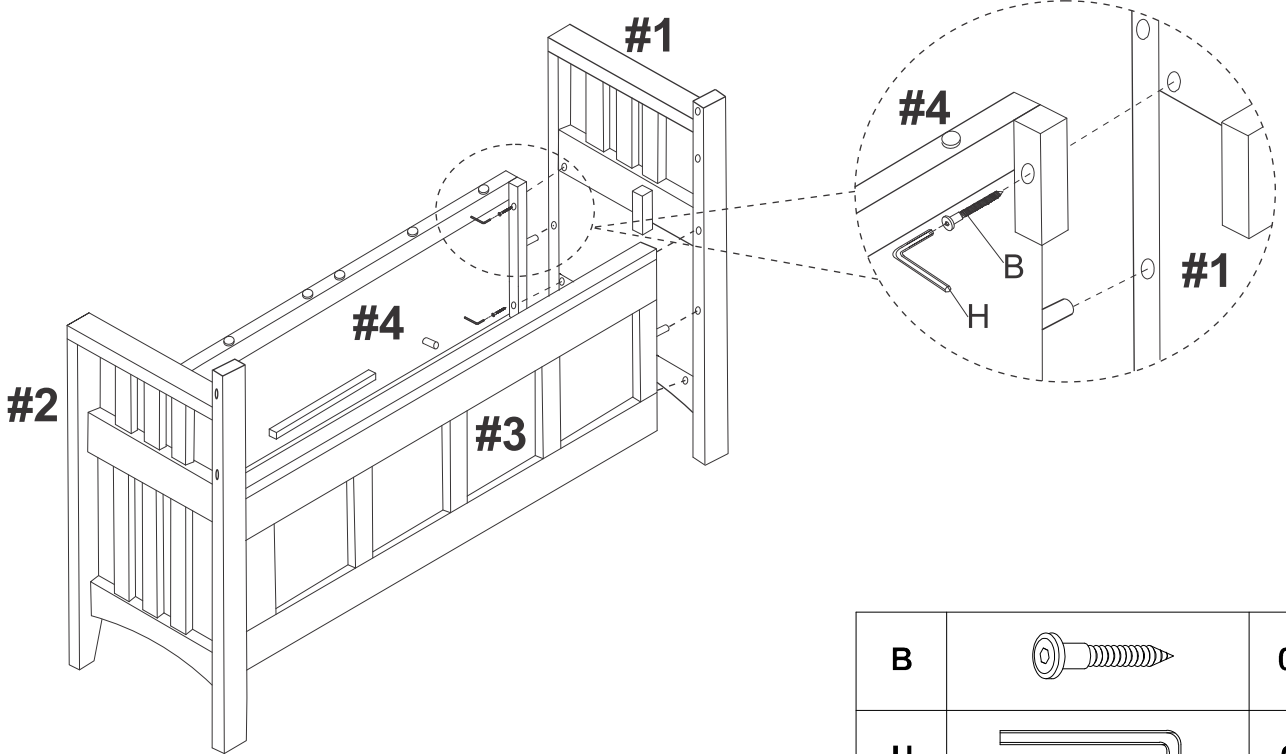

B		04
H		01

4.

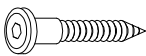



B		04
H		01



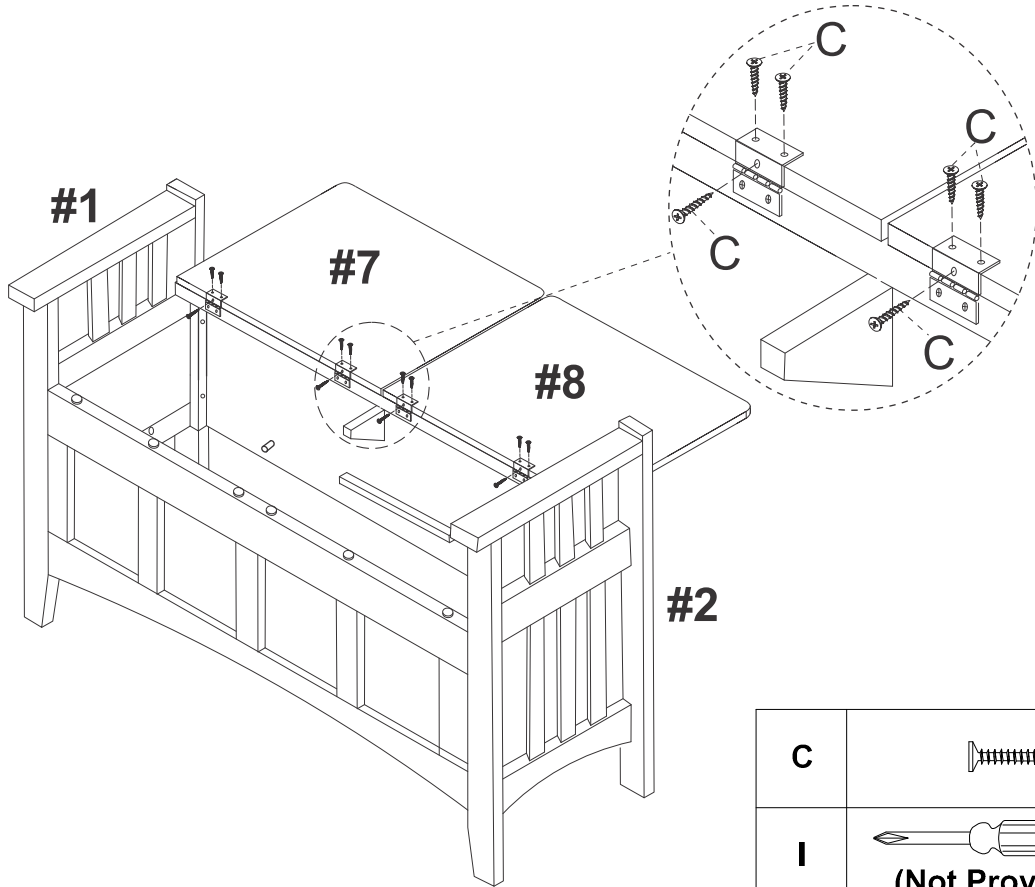

5.

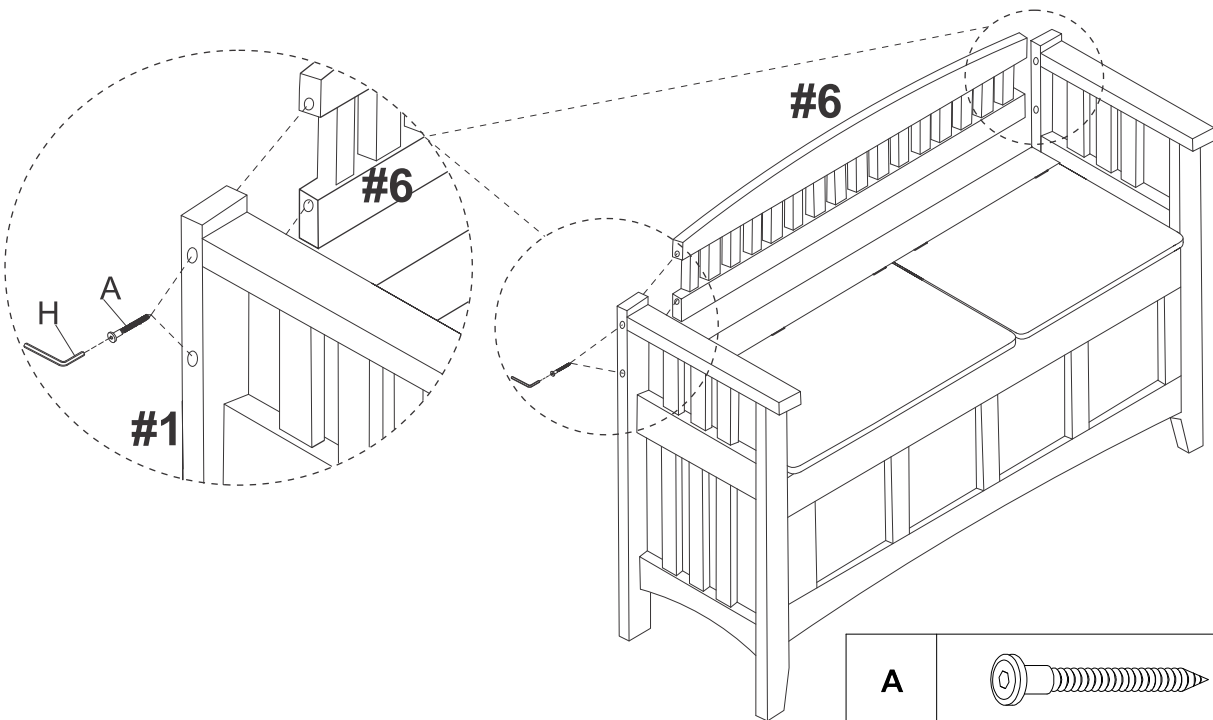

C		12
I	 (Not Provided)	01

6.



A		04
H		01



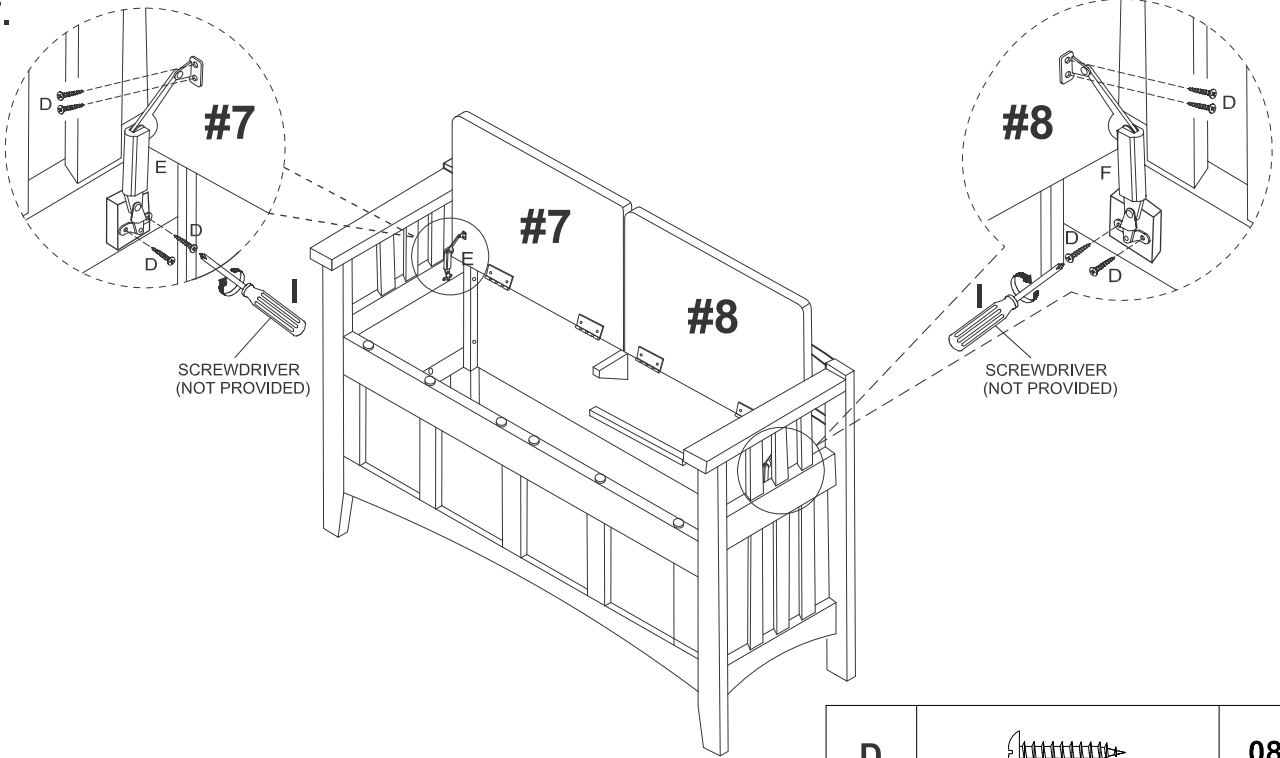

7.

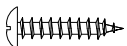

SCREWDRIVER  
(NOT PROVIDED)

SCREWDRIVER  
(NOT PROVIDED)

D		08
I	 (Not Provided)	01

8.

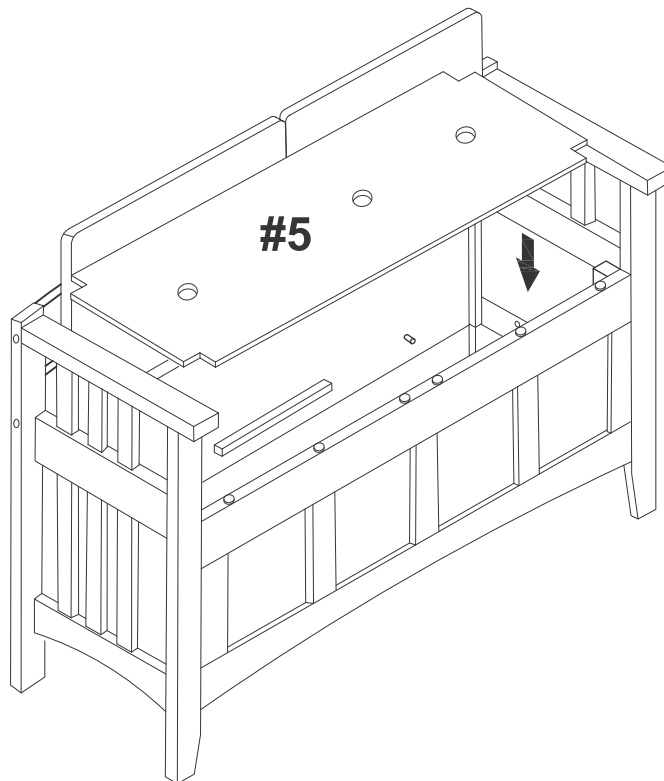



9.

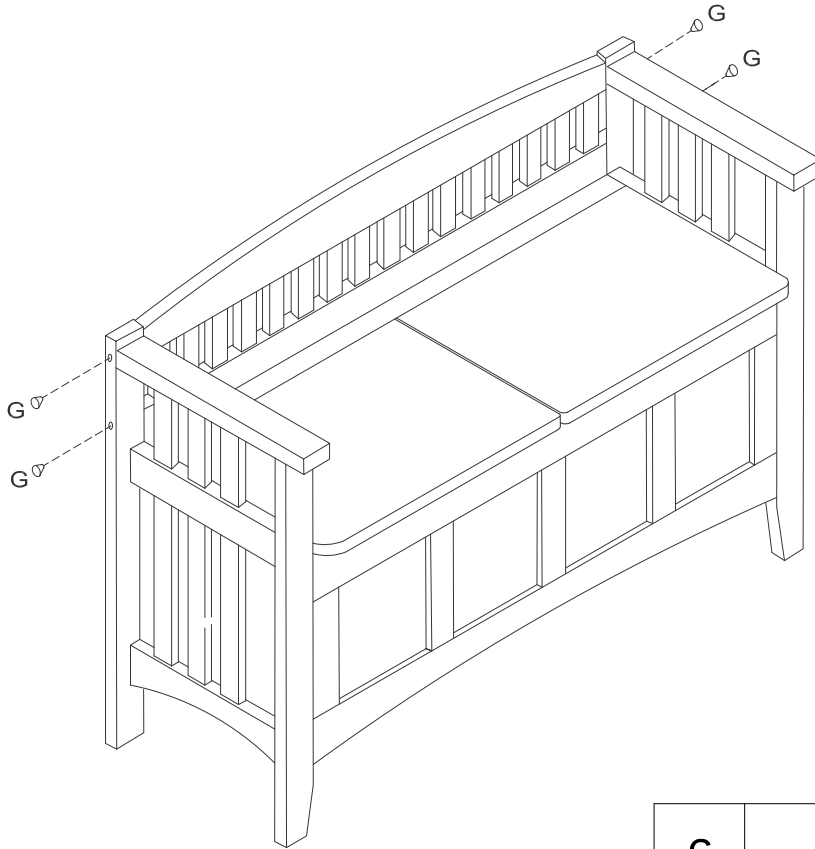

G



04

**COMPLETED ASSEMBLY**

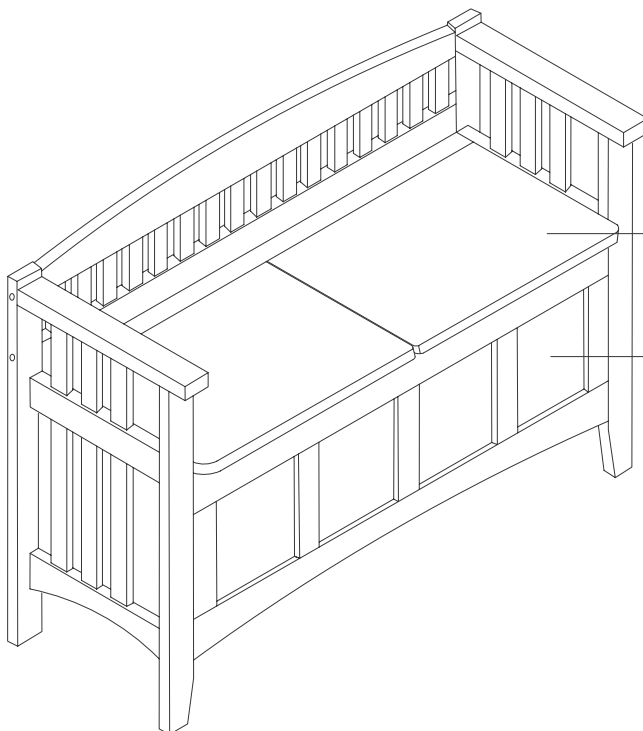

**WEIGHT LIMITS**

SEAT: 275LBS  
COUVERCLE: 124,7 KG (275LB)  
CUBIERTA: 124,7 KG (275LB)

STORAGE BOTTOM 30LBS  
COFFRE: 13,6 KG (30LB)  
BAÚL: 13,6 KG (30LB)



## LIMITED 6 MONTHS WARRANTY GARANTIE LIMITÉE DE 6 MOIS GARANTÍA LIMITADA DE 6 MESES

### WHAT IS COVERED

This product is covered under our manufacturer's 6 months limited warranty (Linon Home Décor Products). To ensure your complete satisfaction, this warranty to the original purchaser that the Linon supplied item is free from defects in material and workmanship, as of the date of purchase, and that it will under normal use and proper care, remain so for six months after the date of purchase.

Replacement of missing or initially defective parts will be sent, at no charge, for a period of 30 days from the date of purchase with valid proof of purchase providing the parts are available in our warehouse and the item purchased is part of our current inventory.

### WHAT IS NOT COVERED

It remains the customer's responsibility for freight and packaging charges to and from the customer service center. Labor and material charges to remove or replace parts under this warranty are not covered. This warranty does not cover: Furniture used for commercial purposes, failures caused by improper installation assembly or by improper care, unreasonable or abusive use (weight limit: 250lbs), freeze damage, acts of God, rust, purchased parts or return freight and packaging charges. Proof of purchase (dated register receipt) is required for this warranty claims.

### HOW TO OBTAIN SERVICE

For further information, please contact our customer service department, c/o Linon Home Décor Products, Inc., between 9:00 AM and 5:00 PM Eastern Standard Time, Monday through Friday:

#### CUSTOMER SERVICE DEPARTMENT:

- 1) Email address:  
consumersupport@linon.com
- 2) Toll free number:  
1 - 800 - 262 - 1852

**#85001WALZ-01-KD-U**

MADE IN VIETNAM  
FABRIQUÉ EN VIETNAM  
HECHO EN VIETNAM

(V39)

### QU'EST-CE QUI EST COUVERT

Ce produit est couvert sous une garantie limitée de 6 mois offerte par le fabricant. Afin d'assurer votre entière satisfaction, cela garantit à l'acheteur original que le produit fourni est exempt de défauts de matériaux et de fabrication à compter de la date d'achat, et ce, sous des conditions d'utilisation normales et de soins adéquats, valide pendant six mois après la date d'achat.

Le remplacement de pièces manquantes ou défectueuses dès le départ sera envoyé, sans frais, pour une période de 30 jours suivant la date d'achat avec une preuve d'achat valide pourvu que les pièces soient disponibles dans notre entrepôt et que l'article acheté fait partie de notre inventaire actuel.

### QU'EST-CE QUI N'EST PAS COUVERT

Il y va de la responsabilité du client de couvrir les frais de transport et d'emballage vers et à partir du centre de service après-vente. Les frais de la main-d'œuvre et des matériaux pour retirer les pièces ou les remplacer sous cette garantie ne sont pas couverts.

Cette garantie ne couvre pas: les meubles utilisés à des fins commerciales, les défaillances causées par un mauvais assemblage ou entretien (sans dépasser les limites de poids), l'utilisation déraisonnable ou abusive, les dommages causés par le gel, la rouille, les frais de transport et d'emballage pour des pièces achetées ou retournées. Une preuve d'achat (reçu de caisse daté) est requise pour les réclamations sous garantie.

### COMMENT FAIRE POUR OBTENIR DU SERVICE

Pour de plus amples renseignements, veuillez communiquer avec notre département du service à la clientèle, entre 9h et 17h HNE, du lundi au vendredi,

#### CENTRE DE SERVICE À LA CLIENTÈLE:

- 1) Adresse de courriel:  
consumersupport@linon.com
- 2) Numéro de téléphone sans frais:  
1 - 800 - 262 - 1852

### QUÉ ESTÁ CUBIERTO

Este producto está cubierto por la garantía limitada de 6 meses de nuestro fabricante. Para asegurar su total satisfacción, ésta garantiza al comprador original que el artículo proporcionado se encuentra libre de defectos materiales y de fabricación, a partir de la fecha de compra, y que permanecerá en tal estado, sometido a un uso normal y cuidados adecuados, durante los seis meses posteriores a la fecha de la compra.

Las partes faltantes o que presenten defectos al inicio de ese período de tiempo serán enviadas sin cargo, durante un lapso de 30 días a partir de la fecha de compra, mediante la presentación de un comprobante de compra válido, siempre que las partes estén disponibles en nuestro almacén y el artículo adquirido sea parte de nuestro inventario actual.

### QUÉ NO ESTÁ CUBIERTO

El cliente asumirá los costos de flete y empaque hacia y desde el centro de servicio de cliente. Los cargos de material y mano de obra para extraer o reemplazar partes en el marco de la garantía no están cubiertas.

Esta garantía no cubre: muebles utilizados con fines comerciales, fallas causadas por montaje de instalación inadecuados o uso indebido (se recomienda no exceder los límites de peso), uso no razonable o abusivo, daños por congelación, oxidación, partes compradas, flete de devolución y cargos de empaque. Se exigirá el comprobante de compra (la factura de registro con fecha) para hacer valer la garantía.

### CÓMO OBTENER SERVICIO

Si desea más información, póngase en contacto con nuestro departamento de servicio al cliente, de lunes a viernes entre las 9:00 am, y las 5:00pm, hora estándar de los Estados Unidos.

#### DEPARTAMENTO DE SERVICIO AL CLIENTE:

- 1) Correo electrónico:  
consumersupport@linon.com
- 2) Número telefónico gratuito:  
1 - 800 - 262 - 1852