



|                  |       |
|------------------|-------|
| CUSTOMER NAME    | PHONE |
| DESIGNER NAME    | PHONE |
| APPOINTMENT DATE | TIME  |

## MEASURING GUIDE

### MEASURING YOUR SPACE

Accurate measuring is a critical step in the remodeling process. Measurement errors are a source of significant delays and costly overruns.

Obtaining a professional measurement of your space is highly recommended – talk to your designer for more details.

Before your designer can begin to design your new space and help you select your cabinetry and appliances, they will need to know the size of your space and the important construction details.

This guide walks you through the 5 easy steps to create a drawing and provide the information necessary for your kitchen designer to start the design process.

- Floor Plan Drawing.....pg 4  
A birds-eye view of your space
- Wall Elevation Drawings.....pg 4  
A vertical and horizontal map of each wall, from a straight-on view
- Construction Details.....pg 5  
Important information for your renovation project
- Appliances.....pg 5  
Dimensions and manufacturer’s specs for your appliances
- Photography.....pg 5  
Photos of your space before renovation

### IMPORTANT NOTES ABOUT MEASURING FOR RENOVATIONS

#### Measure in INCHES

Cabinets and appliances are measured in inches, so your drawings should be recorded in inches, not feet and inches.

**Example: 138-1/8-in,** NOT 11-ft 6-1/8-in

#### For walls and openings, ROUND DOWN

When you measure ceilings, walls and openings, round down to the nearest 1/8-in.

**Example: 138-1/8-in,** NOT 138-3/16-in

#### For appliances, ROUND UP

When you measure appliances round up to the nearest inch.

**Example: 34-in,** NOT 33-11/16-in

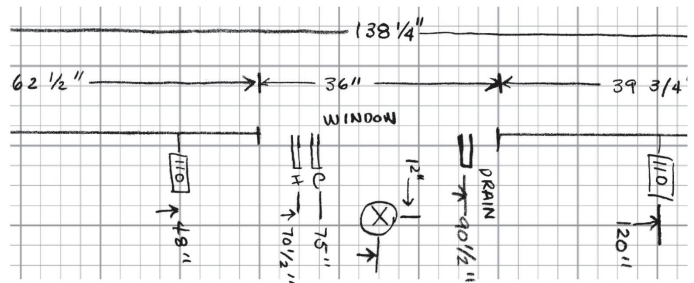

#### Recording your measurements

We’ve provided graph paper to help with your final drawings. It is much more important to record accurate dimensions, rather than draw your room to scale. Be sure to write the actual dimensions on your drawings for all the elements in your space.

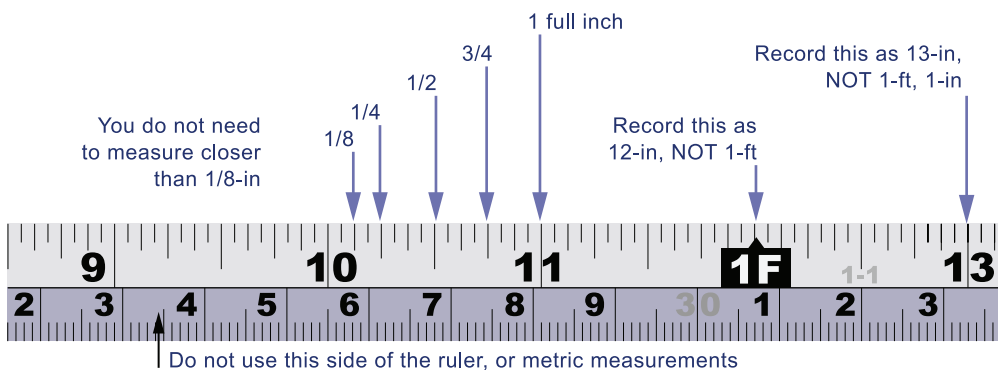

#### USE ONLY METAL MEASURING TAPES

Cloth or plastic tapes may stretch, causing measuring errors.

Standard construction materials are measured in inches. Use a imperial tape measure and record your dimensions in inches, not feet and inches.

## MEASURING TIPS

Here are helpful tips on how to properly measure your space and record the correct window, door and utility information for your floor plan and wall elevation drawings.

Always double-check your measurements!

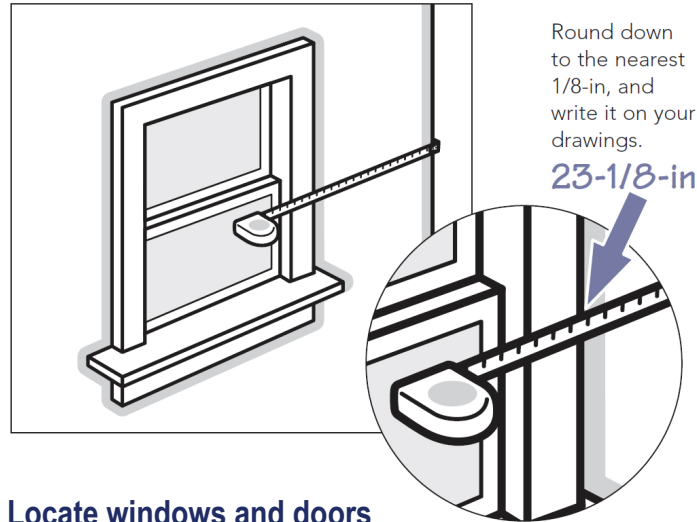

### Locate windows and doors

Measure from the wall to the outside edge of the trim on all your doors and windows.

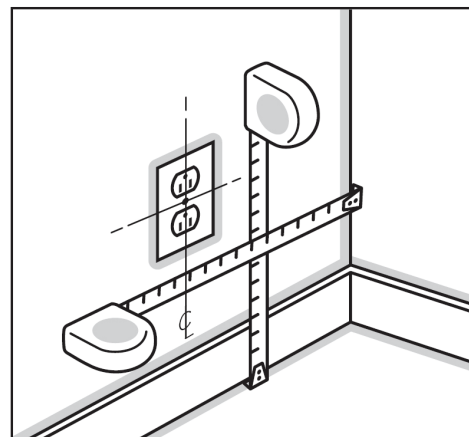

### Locate outlets and switches

Measure horizontally to the center of the wall plate, and vertically from the floor as shown.

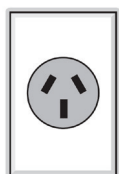

### 220 volt outlets

Be sure to show any 220 volt outlets on your drawing. Do you have an electric stove? Then you'll have a 220 volt outlet for your stove. Your outlet may not look exactly like the example shown here, but it will look different from standard 110 volt outlets.

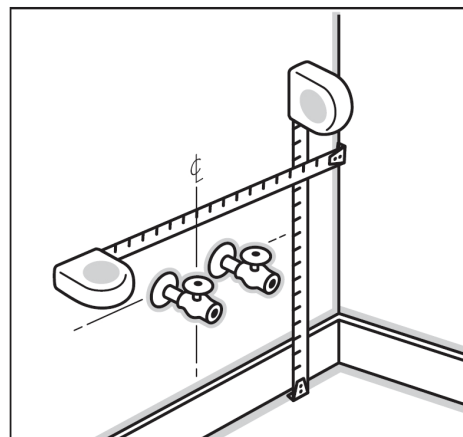

### Locate water and utility lines

Mark the center line location of the sink, water lines, drains, gas lines and heating / air conditioning vents.

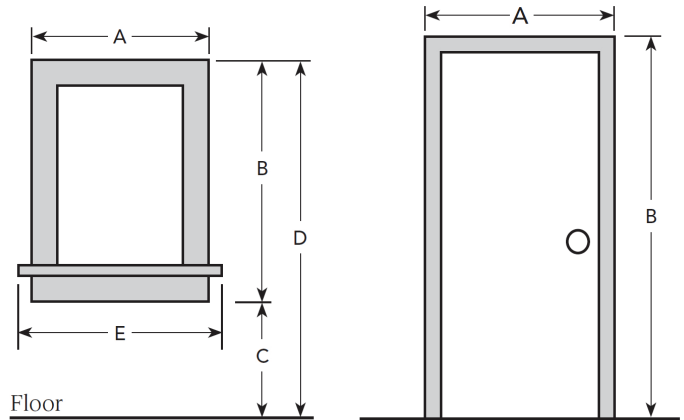

### Measuring doors and windows

Your designer needs to know the exact location of windows and doors, as well as the size of each opening (including the trim) in order to plan your new space.

Record all of the measurements:

- A. Width, including trim
- B. Height, including trim
- C. Distance from floor
- D. From floor to top of window
- E. Width of the window sill

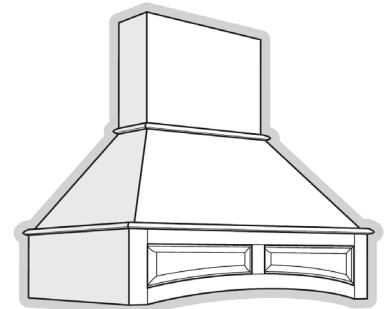

### Range hoods

If you have an existing range hood vent or over the range will be microwave, note the location on your drawing. Specify if it exhausts back into the room, or if it has ducts that went to outside.

## IMPORTANT!

**Be sure to write the measurements on your drawings!**

Most grid paper is to scale, but your designer won't know what size your space is unless you write down the dimensions.

# CREATING WALL ELEVATION DRAWINGS

Elevation drawings are a straight-on view of each wall, with all the features measured vertically and horizontally, placing them on the wall space. This helps your designer locate your new cabinets and appliances along your walls.

## Start with the sink wall, go clockwise from there

Start measuring your room with the sink wall. Label this wall *Wall A*. Then go clockwise around your room, labeling the walls *B*, *C*, and *D*.

## Draw a rough sketch

Start by drawing a rough sketch (or two!) of each wall on a separate sheet of paper.

## Measure the width of the wall

Measure the full width of each wall, beginning in the left corner. Check the width at two locations, 6 inches above the finished floor and 6 inches below the ceiling. Use the smallest dimension.

## Measure the height of the wall

Measure the full height of each wall, beginning in the left corner. Check the height at two other locations. Use the smallest dimension.

## Locate the openings

Measure to the outside edge of the trim. Then measure from the outside trim edge to the next opening, or to the far wall. Follow our measuring tips to capture all the important details about windows and doors.

## Locate fixtures and utilities

Measure horizontally to the center of outlets, switches, water lines and other utilities. Also measure the distance of the items from the floor. If there are HVAC wall vents, mark their location and size. Follow our measuring tips for accuracy.

## Transfer measurements to grid

Transfer all of your measurements to the grid pages in this guide. Label your drawings *Wall A*, *Wall B*, *Wall C* and *Wall D*. Then begin the floor plan drawing.

If your space is L-shaped or has a bump-out area, you can still draw an elevation view straight-on. Just use a vertical line to show where the wall comes forward.



If your floor plan looks like this drawing...

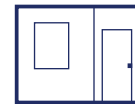

...your elevation view will look like this drawing.

## ELEVATIONS: SINK WALL, WALL A

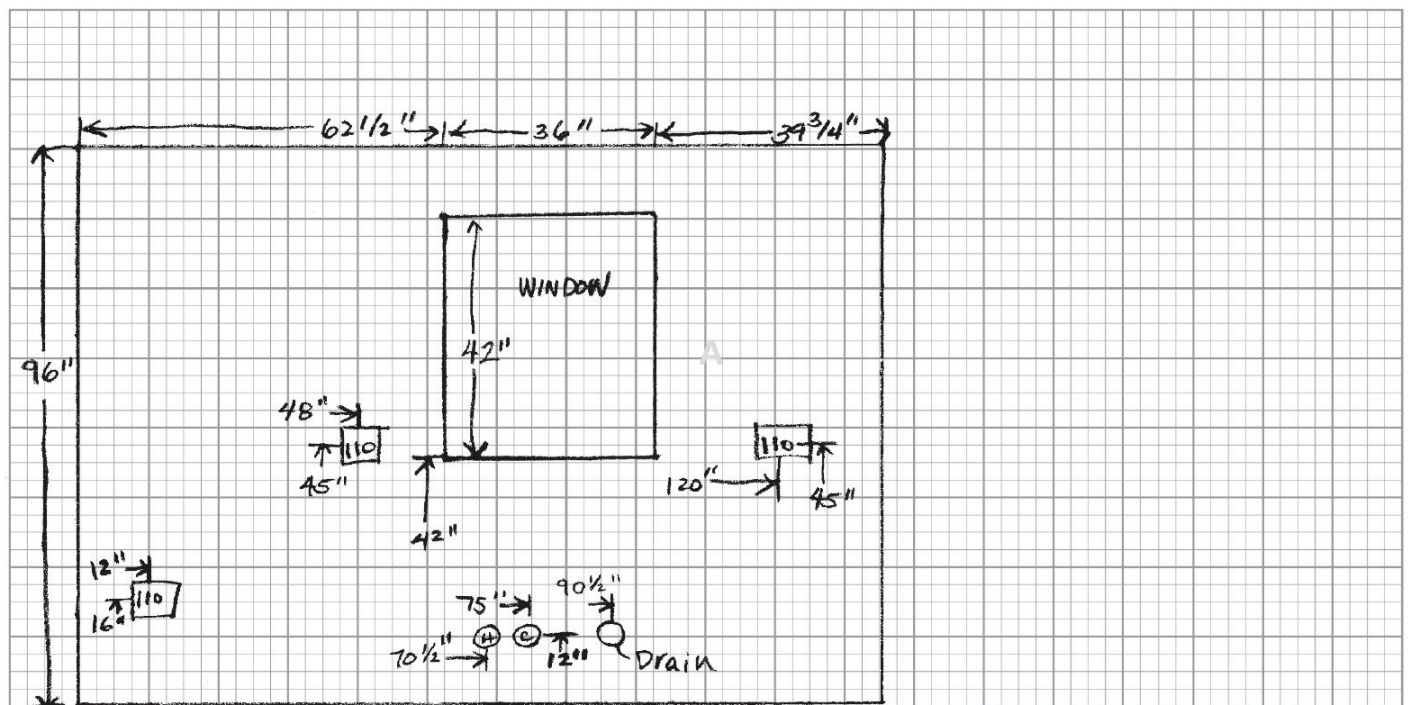

Scale: 1/2-in = 1-ft

Always double-check your measurements! The total of your wall segments should equal your overall length.

# CONSTRUCTION DETAILS

## ENTRANCES AND ACCESS

To make sure your new products fit through doorways into your space, record the actual openings for doors and hallways.

Entry Door: \_\_\_\_\_ inches

Interior Door 1: \_\_\_\_\_ inches

Interior Door 2: \_\_\_\_\_ inches

Hallway: \_\_\_\_\_ inches

Is there a basement or crawl space under the room that provides access to plumbing and heating ducts?

Yes  No

## Soffits

A soffit, also called a bulkhead, is a wall section that is built out at the ceiling level, usually in the area above wall cabinets.

Does the room have soffits?

Yes  No

**If yes please fill out two dimensions in the diagram to the right.**

Do you plan to keep the existing soffits?

Yes  No

Will the soffits have recessed lighting after the renovation?

Yes  No

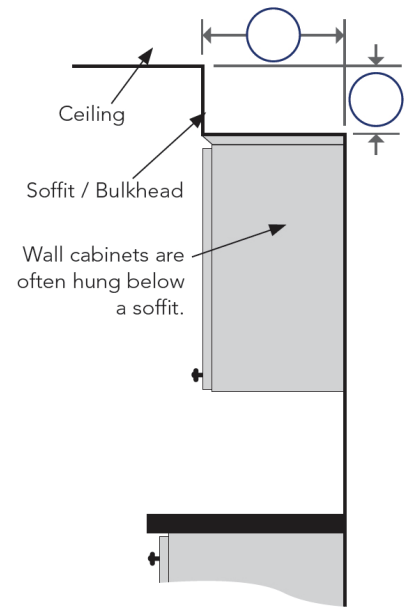

## WARNING

Soffits typically contain electrical and plumbing elements that can't be relocated. Consult a professional on your remodel.

## APPLIANCES

Use this page to provide the dimensions of your appliances or appliance cut-outs.

Refrigerator Model No.

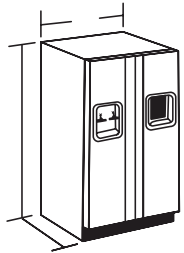

W \_\_\_\_\_

H \_\_\_\_\_

D \_\_\_\_\_

Double Door

Single Door

Left  Right

Sink Model No.

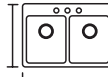

Single

1-1/2

Double

W \_\_\_\_\_

D \_\_\_\_\_

Range Model No.



W \_\_\_\_\_

H \_\_\_\_\_

D \_\_\_\_\_

Slide-in

Raised Back

Cooktop Model No.   
(Cut-out Dims.)

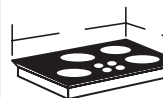

W \_\_\_\_\_

H \_\_\_\_\_

D \_\_\_\_\_

Front Controls

Top Controls

Dishwasher Model No.

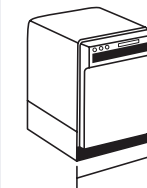

W \_\_\_\_\_

H \_\_\_\_\_

D \_\_\_\_\_

Model No.



Double Oven  
(Cut-out  
Dimensions)

W \_\_\_\_\_

H \_\_\_\_\_

D \_\_\_\_\_

Other Appliances

Description \_\_\_\_\_

W \_\_\_\_\_

H \_\_\_\_\_

D \_\_\_\_\_

Description \_\_\_\_\_

W \_\_\_\_\_

H \_\_\_\_\_

D \_\_\_\_\_

## PHOTOGRAPHY



Take photos of your space and share them with your kitchen designer. Label your photos to match your walls: A, B, C, D.

- Straight-on views of each wall: A (the sink wall), B, C, D (go clockwise around the room).
- Photos of soffits or other construction details.
- Close-ups of anything unusual in your space: air vents, plumbing or gas lines, entrances or access notes.